

SPRAT

THE JOURNAL OF THE G QRP CLUB

DEVOTED TO LOW POWER COMMUNICATION

ISSUE Nr. 143

© G-QRP-CLUB

Summer 2010

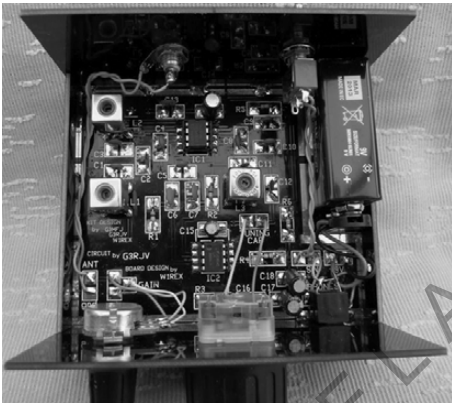

Limerick Sudden Kit

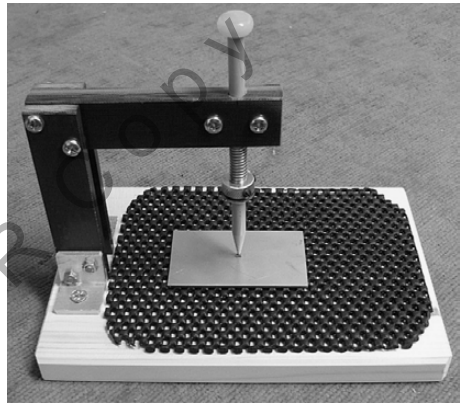

SMD Soldering Jig

Rishworth Convention ~ 2x3 Transceiver ~ SMD Jig ~ Solder Paddle
Practical Tips ~ Roller Coaster Coil ~ Takeaway Receiver
Best Diode ~ Single ended TDA7052 ~ BITX on 12m ~ Fishy Business
RF Power Attenuators ~ Free Retro AM Draw ~ More Spectrum Coils
Limerick Sudden Kit ~ Antenna – Anecdotes – Awards
ZL Membership News ~ G3PDL SK ~ Communications & Contests
Member's News ~ Club Sales

JOURNAL OF THE G QRP CLUB



© G QRP CLUB

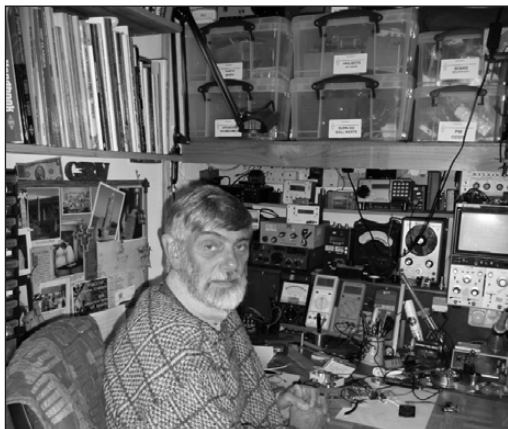

Rev. George Dobbs G3RJV

**9 Highlands
Smithy Bridge
Littleborough, Lancs.
OL15 0DS. U.K.**
Tel: 01706 - 377688
(overseas tel: +44 1706 377688)
Email : g3rjv@gqrp.co.uk
Homepage : www.gqrp.com

I did promise to announce the winner of the W1FB Award in the last issue but I received an entry too late to put in the last issue but just in time to enter. It appears in this issue. After much thought I have awarded the 2009/2010 plaque to Steve Webber, KD1JV for his "Rig for MAS" in SPRAT 140. The award for 2010/11 was inspired by the Solder Paddle of IK1ZYW; a useful station accessory made from everyday things. I will use Paolo's article as the first entry.

The last quarter has been saddened by the death of Peter, G3PDL, who was club treasurer for over 20 years and a personal friend of some 50 years. On a brighter note we have introduced the first club kit for many years; the **Limerick Sudden**; a novel approach to an old design. It was well received at Dayton where we sold all the 50 kits we took. We hope to produce further "Limerick" style kits in the near future.

72/3

G3RJV



The W1FB Memorial Award 2010/2011

The project is to **Design a Useful Accessory for a QRP Station**. This can include any useful station addition with extra consideration given to innovation. Improvements on existing designs could be accepted. Please submit your design to G3RJV by the **end of March 2011**, with circuit diagrams, all values and brief notes.

The projects will be published in SPRAT and the winner will receive an engraved plaque.



THE G QRP CLUB MINI-CONVENTION

(in conjunction with the Halifax Radio Society)

Saturday 23rd October 2010
The Rishworth School, Ripponden

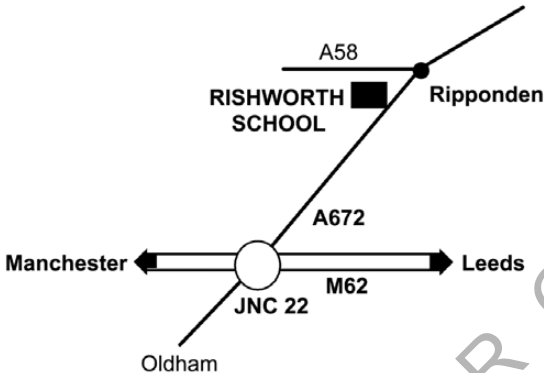

OPENS AT 10.00am

ADMISSION £2

DOORS OPEN 10am

TALK-IN S22

**LARGE SOCIAL AREA LEC-
TURES ON**

QRP SUBJECTS

BRING & BUY - SURPLUS

JUNK - COMPONENTS

KIT TRADERS

FOOD & DRINK ALL DAY

WITH THE FAMOUS PIE AND

PEAS

**The Rishworth School is on the A672 (Ripponden) road
from Junction 22 on the M62. [Postcode: HX6 4QA]**
Look for the G QRP Sign on the left after you have passed all the sheep!

LOCAL ACCOMMODATION:

Look on the club webpage or ring G3MFJ [0113 267 1070] or G3RJV [01706 377688]



Large Hall Space for traders

Dedicated Lecture Theatre

On-site Car Parking

**To book a table (or tables),
contact Dick, G0BPS, on
01303 894 390, or by email to
tables@g0bps.com**



The 2 x 3 Transceiver

K.P.s. Kang

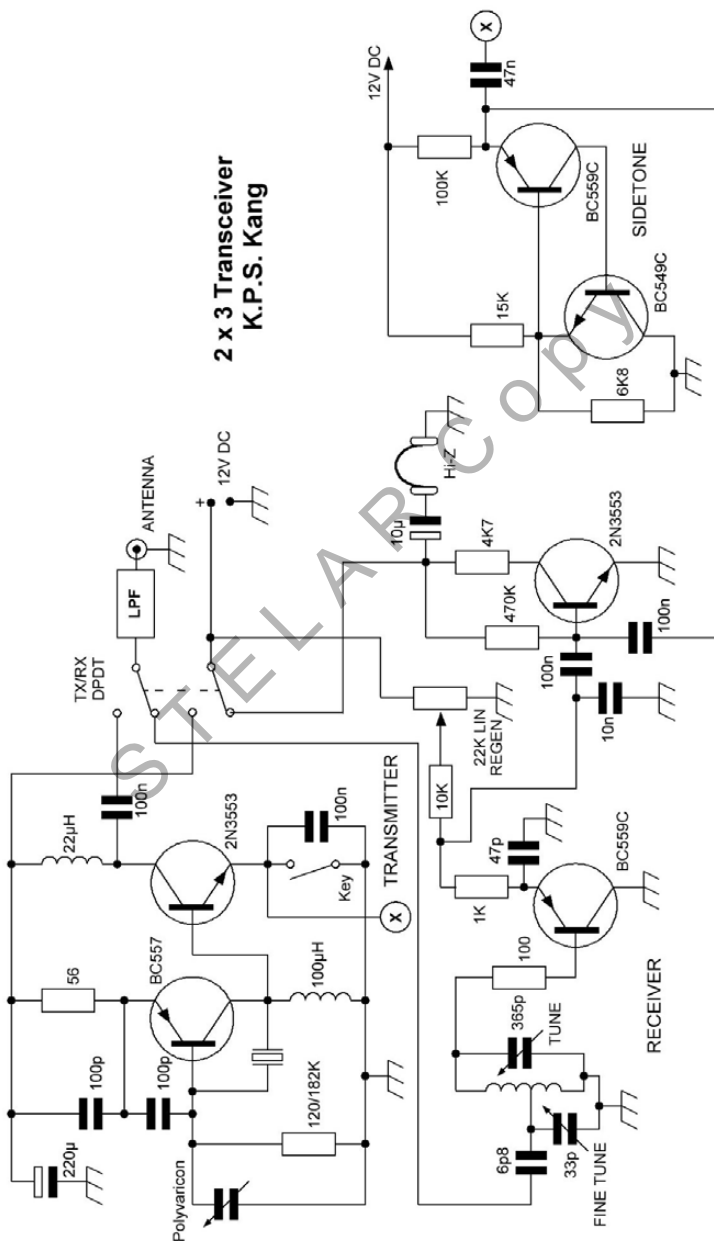

2 x 3 Transceiver
K.P.S. Kang

The rig is named 2 x 3 as I used two transistors (one NPN and one PNP) in three stages; TX, RX and sidetone. The rig was made ugly style however kits are available with a commercial PCB for \$10 (+ \$3 for postage overseas). The kits do not include variable capacitors and LPF.

The transmitter is straight forward; a modified VU-mini transmitter. The oscillator transistor is replaced with a PNP device; this ensures little bias to the 2N3553 and thus a little more output. The circuit is quite dependable.

The receiver is a two transistor regenerative receiver with its first stage running continuously. I have not furnished the RX tank circuit values here but they can be found experimentally. For my 80m version I used 12 turns on T50-6 core tapped at nine turns from ground. The RX is quite elective and sensitive. Using high impedance magnetic phones a signal of -109dbm is plainly audible.

The sidetone is a simple relaxation type. As the key is pressed the open end of the 47n capacitor goes to ground and the audio is heard.

I have tried to squeeze the maximum from each available component to keep the transceiver as simple as possible with minimum parts count. On the day it was completed the rig was put into use at VU3OJA and the first contact established that evening with a 549 report.

Beware of fake 2SC1969

David Smith. G4COE. 54, Warrington Road, Leigh, Lancashire

Beware of fake 2SC1969 TO220 RF power transistors, the fakes are from China and stands out like a sore thumb, these transistors are usually used in 27Mz CB equipment and can churn about 16 Watts out, these may be found in PA stages in amateur equipment and may be used in some designs of RF PA circuits.

You would be very lucky if you got more than a couple of Watts out of the fake devices as the slab that the device is made on is much smaller than the original Mitsubishi devices when broken open.

The fake devices are usually shiny looking devices instead of the dull grey, right in the middle is a indent with the batch number alongside to the right and the main device number i.e. 2SC1969 along the bottom edge, they carry the usual Mitsubishi log on the top. The real devices are dull in colour, with NO indent in the middle, the device number also being in the middle while the batch number is on the bottom edge, reverse of the fakes. It has been commented that some fake devices has a different edge on metal tab and the hole being slightly larger than normal.

See this U tube video <http://www.youtube.com/watch?v=avsICAgPfkY> and here is an actual test <http://www.youtube.com/watch?v=KEy5VkrOY4>.

The result of these fakes is usually low power output and over-heating problems, as well as not lasting long.

A Soldering Jig for SMD Components

Duncan Walters G4DFV

11 King George V Avenue, Mansfield NG18 4ER

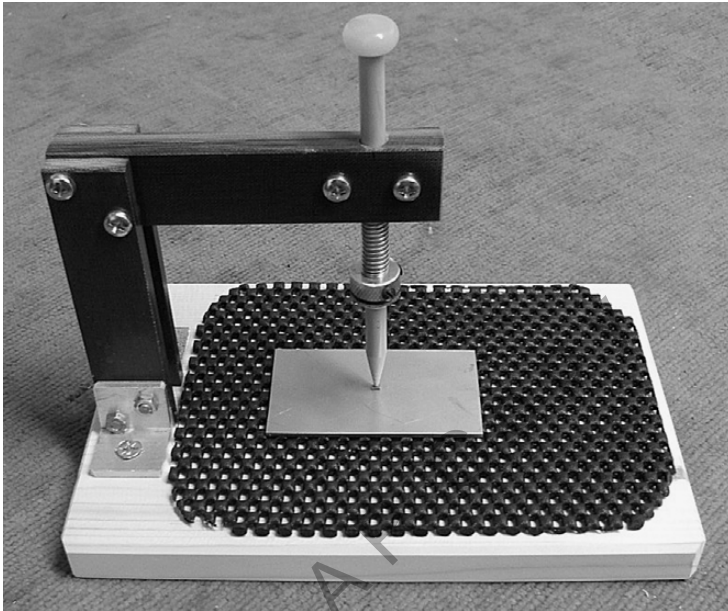

This jig is a handy device that makes it easier to hold surface mount components while soldering. Simple in design and easy to build, it is surprisingly effective for the job. It is based upon an earlier design by Albert Heyes G3ZHE (Technical Topics, RadCom Sept 2006).

In my version, I used 2 inch (6mm) thick SRBP for the uprights and cross pieces, simply because I had the material to hand, but there is no reason why it cannot be fabricated from wood.

The vertical plunger is made from a top section of 7mm plastic knitting needle that is sprung-loaded using a compression spring. A brass boss (removed from a bakelite control knob), is fitted on the shaft and can be fixed by means of the two original grub screws. By sliding it up and down the shaft, it functions as a tension adjustment to set the required pressure on the components. The original centre hole of the boss was drilled out large enough to accommodate the diameter of the knitting needle.

A point is filed on the end of the knitting needle, similar to a pencil point. The size at the end is about 1.5mm, and flat. This is suitable for holding 1206 size SMD's, which is about the smallest I can cope with!

My knitting needle was made of thermo-setting plastic, similar to Bakelite, so it will resist heat of the soldering iron.

Here is a close up showing the jig in operation:-

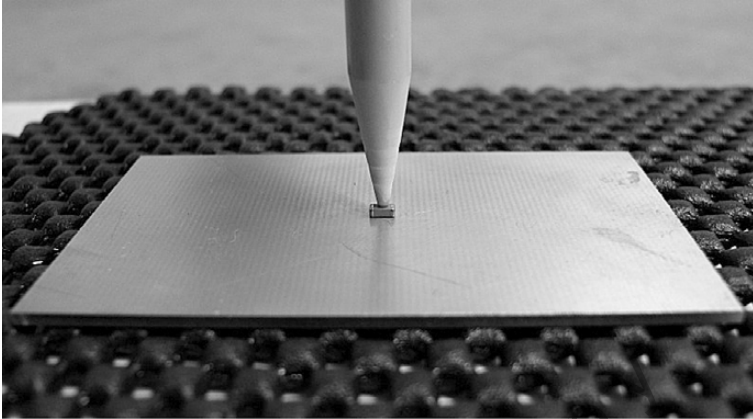

The jig is built on a piece of softwood measuring 8 x 5 x 3/4 inches, the two uprights are each 4 x 1 x 1/4 inches, the two cross pieces are 4.5 x 1 x 1/4 inches (or 1 piece of 4.5 x 1 x 1/2 inches if using wood).

The uprights are mounted on the base using two pieces of 7/8 x 7/8 inch aluminium angle, 1 inch wide.

The device is held together using M3.5 nuts and screws and fixed to the base using countersunk woodscrews. A useful finishing touch is adding a piece of non-slip rubbery “dash mat” material, cut to size and stuck down using contact type adhesive.

The non-slip material can be obtained from local car accessory dealers

Kanga Products is back...

**KANGA
PRODUCTS**



By the time you read this the main launch of **Kanga Products** will have passed this being the Red Rose QRP Festival at Formby Hall Atherton. I would like to take this opportunity to thank all customers new and old that came to the stall and purchased or introduced themselves and gave their

supported to the Launch, also not forgetting those who attended the mini launch back in April at the Blackpool Rally

Our website is now showing a range of kits this includes some of the old favourites such as the Foxx-3 CW transceiver, the DIY Amplifier and the range of Sudden Receivers which are suitable for the constructional projects required as part of the Intermediate Exam.

Future event: **Stockport Rally** (formally Reddish) 3rd July 2010

Full details can be found at www.kanga-products.co.uk

or by emailing sales@kanga-products.co.uk

Thank you again for your continued support. Dennis G6YBC

The Solder Paddle

Paolo Cravero, IK1ZYW, via Forlì 157, Torino 10149. Italy

Over the past 10 years I have tried to reproduce most simple paddle project, both from the Internet and past issues of HAM publications, with mixed results that would put me on the air at my proficient speed of 15 WPM. With that experience in mind I have come up with a paddle project that requires no electric tool to be built, except a soldering iron. The resulting paddle is lightweight (as low as 25 grams / 0.9 oz including cable!), cheap and it is a mix between Ref. 1 and Ref. 2.

My key is composed of two raw materials: unetched PCB and gold-like plated paper clips. Tools needed: file, heavy duty paper cutter, pliers with cutter. First of all, you create the key base: cut a rectangle of about 4x7 cm (1.5x2.8 in) of PCB using your preferred/usual method. With a file round the corners and borders. Then draw two “L” back to back as shown in the diagram, first with a pen/pencil, then etch the lines with the cutter until there are three islands of copper, insulated from each other (use an ohmmeter). Moving the cutter back and forth speeds up the etching process. The “T” shaped area will host the common connection, while dot and dash come from the remaining two pads.

Move on to paper clips. The picture shows steps better than words.

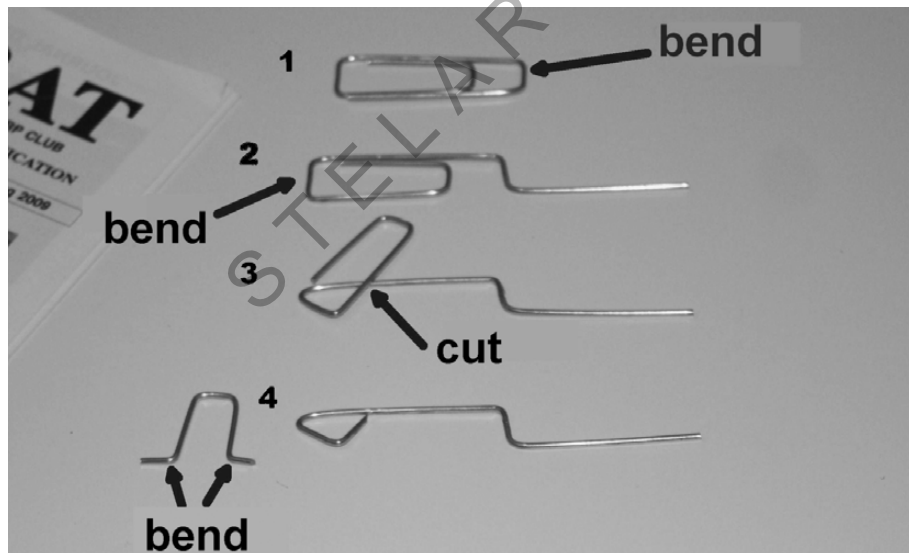

I use two large paper clips with brass/golden look that makes soldering easy. First solder the common contact bridge as depicted in the diagram. I suggest tinning contact points on the paperclip wire in advance. One paddle at a time are next, keeping in mind that you always need a crocodile clip to hold them (unless you like the smell of burnt fingers). Do your best to align the paddles parallel to the base long side, but you'll be able to correct them later. With my paper clips I have found that a distance of 2-3 cm (0.8-1.2 in) between

the common bridge and paddle solder joints gives the best feeling, the shorter being the harder to manipulate. The distance should be the same for both paddles in order to get equal tension from both. Don't worry and solder the paddle in a way that lies against the common bridge.

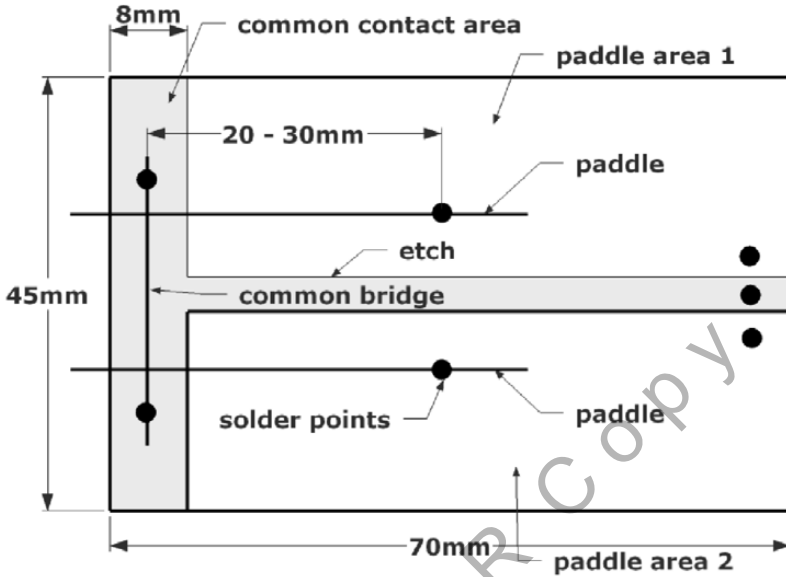

Adjustments. With pliers (or even just fingers) you can control the contact point distance for each paddle and their height from the base. If you want a different tension, you need to resolder them. That's it.



Improvements. You can superglue the paddle to a heavy base for in-shack use. Discarded pieces of marble cuts can be obtained for free from a nearby reworking factory. Guitar picks can provide a larger finger contact area or, for a more vintage look, solder two coins

to paddles before mounting them on the base (use a good deal of heat on demonetised coins containing a good percentage of copper). Add four rubber feet to the heavy base to protect your desk and keep the key in place.

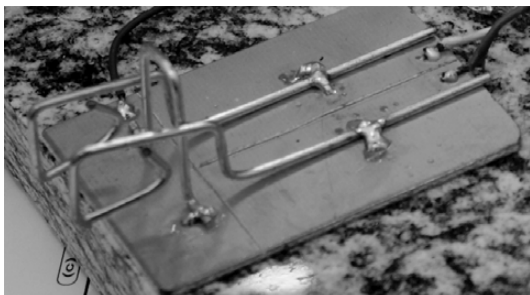

Complete the paddle with a 3-wire cable soldered at the back of the PCB base, ground/common wire being in the middle. If dit and dash are reversed, swap the tip and ring wires. Earbud cable matches this lightweight but sturdy morse key.

Detail of paddle

Proper paper clips can be located in office supply stores. My clip wire is 1.25mm diameter (0.05 inches). Each key requires two clips. I have built several of these and I use them on the air since I do not own a professionally made paddle.

Ref. 1: The "Clipper" paddles by LA5YNA. Ref. 2: NB6M Paddles

Two Practical Tips from G0AED

Jerry Gerard G0AED, 18 Hunstanton Rd. Dersingham, Kings Lynn. PE31 6HQ

Cutting Ferrite Rods without the Hassle

Ferrite rods can be cut to length easily with an electric drill and a Workmate/Vice. Wrap the rod with a layer of electrical insulation tape on the end you are going to put in the chuck. Clamp drill in Workmate/Vice. Place taped end of rod in chuck and give drill a spin to ensure rod is running fairly true. If it is not just loosen chuck and twist rod a bit until it is running as true as you can get it. Start drill and use a tile cutter to cut through hard outer surface of rod. Stop the drill and tap the rod with the tile cutter and it will break off with no trouble at all. I use a piece of wood clamped alongside the drill to act as a toolrest for the cutter. Use eye protection whilst carrying out this process!

Laying out Panel Meters

Laying out panel meters and other items such as variable capacitors can be tedious and not always as successful as we might like. A quick and easy way is to use BLU-TACK. Cut the hole for the meter and place it in the hole. Mark where the mounting studs occur and remove the meter from the hole. Put a blob of Blu-tack at the end of the marks.

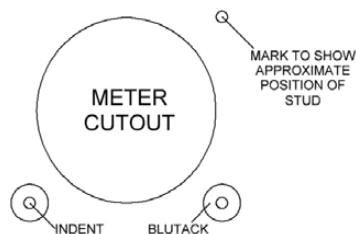

Reinsert the meter and press firmly and you have the positions of the studs. Drill with a fine gauge drill in the centre of the indent and remove the Blu-tack. I always drill the final hole slightly bigger than the body size of the stud as to allow a little adjustment if required. This method works well with those pesky little critters called Polvaricons which seem to give everyone problems.

Making a Roller Coaster Coil

Peter Howard, G4UMB, 63 West Bradford Rd. Waddington Lancs BB7 3JD

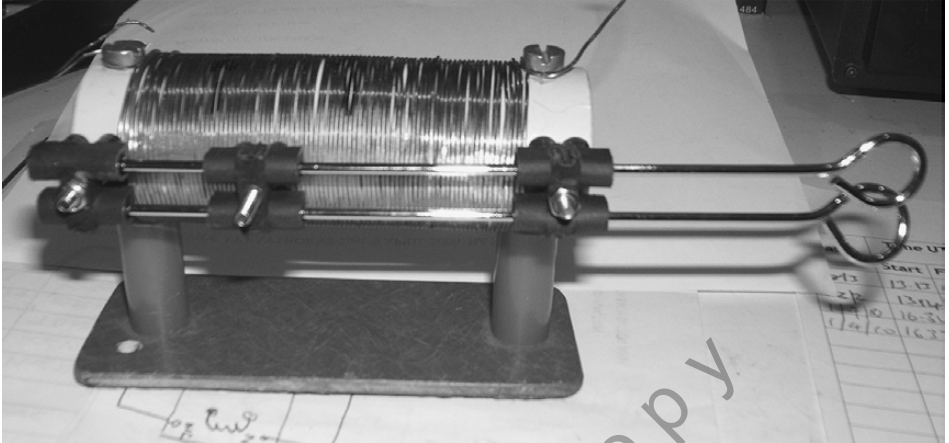

Here's a simple way I found of making a "Roller Coaster" coil.

Although the one I made is wound on a piece of tube from a scrapped vacuum cleaner you could use other types of plastic pipe. The slider as you can see from the picture is made from three pieces of terminal block. The two end blocks are clamped to two meat skewers using the screws in the blocks. I have left the skewers uncut so you can see which sort I used. After the picture was taken I cut the excess off. I used 6BA screws to clamp the two end blocks to the coil former. The coil in my case is about 60 turns of 22swg insulated wire on a 28mm diameter former.

Making the Slider: The sliding block has a 6BA round head screw which is the contact to the coil. This needs to be a loose fit so you may need to enlarge the hole in the block slightly. It is kept in contact with the coil by being sprung loaded by a spring I got from a ball point pen. The spring was cut to about 6mm long. I found that the four moulded posts on the terminal block were just the right size to support the contact screw from being pulled sideways when used. The enamel paint on the coil needs to be removed where the slider makes contact with emery cloth or a light file.

This sort of variable coil is useful when experimenting with aerial matching and Pi Tank construction especially for the lower frequency bands.

A Useful Tip from David M3CCQ

A cheap source of mains 12v 20w transformers is from the 12v Halogen reading lamps....the type with two telescopic arms.....they are available from boot sales for 20p to 50p.....nobody wants them when the bulb has blown.

The "Takeaway Two Regenerative Receiver

Barry Zarucki M0DGQ, Heathfield Rd. Kings Heath, Birmingham. B14 7DB

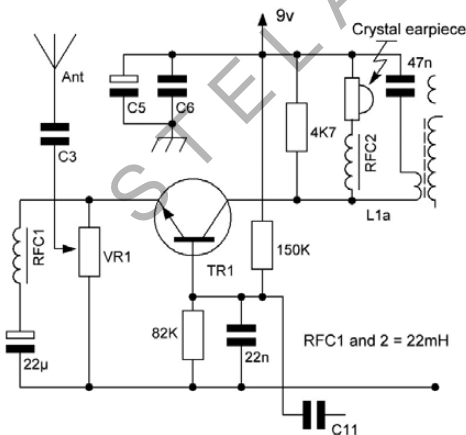
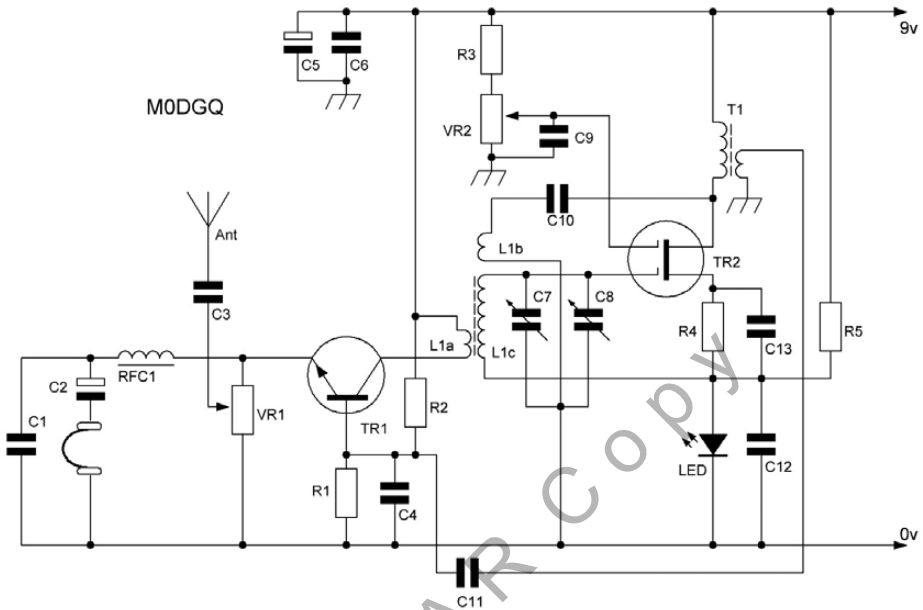

Alternative crystal earpiece circuit diagram

(note: base bias resistors are different value in this alternative circuit diagram)

Here is a very simple receiver capable of resolving CW, AM and SSB transmissions in the frequency range 1.5 MHz to 5 MHz also it is cheap to build. The set uses two transistors and is built on a wooden chassis lined with two takeaway curry tins (hence the title). This is a simple fun project which demonstrates what can be done with a couple of transistors, it is also quite nostalgic for me as some of my first built receivers were regenerative (mine used valves as transistors were quite expensive at the time and the valves came free, courtesy of duff television sets!).

The circuit uses the old principle of regeneration (a very popular technique used in the early days of radio). In simple terms, an active device (transistor or valve) can exhibit gains of many thousands if positive feedback is applied to the circuit, i.e. if it is made to oscillate. Also high gain is achieved (not as high as the above) if the circuit is brought almost to oscillation. As can be seen in the photograph, the circuit is built on a PCB however veroboard or dead bug style will also work fine. The two tuning capacitors used are rather old but modern polycon types will be just as good in this project (G-qrp club sales). The radio drives small ear pipette type headphones (these can be purchased in most "pound" shops) to good volume from signals in the 10uV region so a good antenna is essential for this project (I used 30m of wire trailed in the house roof space). A slightly different circuit is also shown driving a high impedance crystal earpiece. Which one you use is up to you (subjectively I think the ear pip one just has the edge over the crystal earpiece circuit). A separate audio amplifier capable of speaker volume can be added if desired.

CIRCUIT DESCRIPTION

The circuit comprises of two separate stages; an RF preamplifier and the regenerative detector. Tr1 is the RF preamplifier, it provides a small amount of gain but more importantly it isolates the antenna from the following stage; Tr2 the regenerative detector when used for CW and SSB reception has to oscillate at roughly one kilohertz away from the incoming receive frequency in order to demodulate the transmission. Without Tr1 stage this oscillation would be radiated by the antenna causing interference to other nearby receivers.

Tr1 is configured as a common base RF amplifier. The antenna signal via C3 is presented to VR1 (used as a crude RF attenuator) and then to the low impedance input of the preamplifier (Tr1 emitter) which gives a reasonable match. For simplicity this stage is untuned. Bias for Tr1 is provided by R1 and R2. C4 decouples Tr1 base to ground at RF frequencies. L1a is the collector load for Tr1 and couples the amplified RF signal to L1c. L1a only has a few turns providing a good impedance match to Tr1 collector. C7, C8 and L1c form a parallel tuned circuit and it is this tuned circuit that provides the selectivity for the set. The tuned circuit is connected to the high input impedance of Tr2 gate 1 which presents very little loading to the tuned circuit thus maintaining its Q when the detector is not oscillating (AM reception). Tr2 is a dual gate mosfet and its gain/ positive feedback is controlled by varying its gate two DC voltage via R3/ Vr2. LED 1 gives a greater gain range by allowing Tr2 gate 2 voltage to go negative with respect to its source if required. Feedback or regeneration for this stage is achieved by a small coupling winding L1b which is lightly coupled to L1c (L1a, b and c are all wound on the same former); amplified RF signals are present on Tr2 drain, a small proportion of this signal is fed to L1b via C10. L1b winding is arranged such that the fed – back signal passing through L1b is IN phase with the signal in L1c, thus these two signals are thus added, creating a larger amplitude signal. This loop continues until a point is reached where Tr1 will be freely oscillating. It is this oscillation that gives the stage an extremely high gain; a not quite so high gain will also be achieved if the stage is brought just to the edge of oscillation. Another effect of feedback or regeneration is that the Q exhibited by L1c will be hundreds of times greater than normal thus giving a much greater selectivity, as a point of interest this is how Q multipliers work.

As Tr2 is operating in a non linear mode, demodulation of the signal will also occur in this stage (hence the term regenerative detector). The drain load for Tr2 is an interstage audio transformer type LT44; it has a primary impedance of 20 Kohm and a secondary impedance of 1 Kohm. As far as RF is concerned the primary is acting as a high value RF choke due to its large inductance and is the drain load for Tr2, so no RF will pass through the transformer, AUDIO frequencies however will and do pass freely via the transformer to the secondary winding. So, audio is present at the secondary of T1 at a source impedance of very roughly 500 Ohms. This source impedance is not low enough to drive the low impedance headphones (40 ohms or so) to a useable level; a further impedance transformation is needed.

Audio from T1 is fed to Tr1 base via c11. Tr1 base is at RF ground due to C4 (a 22nF) but at audio frequencies its input impedance is high, so we can feed audio in to the base and retrieve from the emitter at a very low source impedance suitable for driving the headphones, in effect, as far as audio is concerned Tr1 is an emitter follower (a buffer) stage. Thus Tr1 is doing two tasks; amplifying RF and at the same time providing audio power gain. RFC1 prevents RF from reaching the headphones which would otherwise severely attenuate the incoming RF signal. C2 provides DC blocking so Tr1 can operate correctly. C11 also provides DC blocking to maintain Tr1's base potential. If an audio power amplifier is to be used, take C11 to amplifier instead of base of Tr1.

ALTERNATE CRYSTAL EARPEICE CIRCUIT

The crystal earpiece circuit is slightly different in operation. Here, we are driving a high impedance load (a crystal earpiece exhibits several megohms impedance), so Tr1 needs to produce voltage gain at audio frequencies. Looking at the circuit, audio is applied to Tr1 base as before but the earpiece is connected across R3. At audio frequencies the combination of the earpiece and the 4.7 Kohm resistor make up the collector load. RFC2 blocks any RF that would otherwise pass through the earpiece's flex, this is done to maintain stability when regen is in use. So, at RF all Tr1 sees as a collector load is L1a in parallel with R3. The impedance presented by L1a is much lower than R3, so realistically all Tr1 sees is L1a. C7 is included to present an open circuit (ish) to audio frequencies, without it the earpiece would be shorted out via L1a, but it maintains an RF path for L1 due to it's low capacitive reactance at RF (effectively it is a short circuit at RF).

Tr1's emitter is connected to ground at audio frequencies via RFC1 and C2, thus providing voltage gain (not power gain as in the previous circuit) at audio frequencies. The AF voltage gain of the stage will be roughly R3 divided by the emitter impedance (the capacitive reactance of C2 @ 1 KHz in series with internal emitter resistance of about 25 Ohms).

IN USE

If you find you can not get your set to oscillate (you will hear a faint "rushing" sound or squealing in the headphones when oscillating), reverse the connections of L1b or L1c. You may notice there are two variable tuning capacitors. The larger one (500 pF) is used as a band set control and the other (50pF) is used as a bandsread (fine tune) control. When the set is used for SSB/CW (i.e. it is oscillating) tuning will be very sharp and practice will be required, large control knobs are recommended for the tuning controls. The ones used here are made from a bleach bottle top and an aerosol can top, these were

filled with finishing plaster to give a “weighty” feel. The RF attenuator VR1 is useful when receiving very strong signals, without it blocking can occur (the set goes into complete silence).

For reception of AM signals the regen control should just be on the brink of oscillation. For CW reception strong oscillation should be used but less for SSB.

A good aerial must be used. An earth may be beneficial to some; in my case it made reception worse as broadcast stations tended to swamp the amateur stations. This receiver is not intended for any serious radio work, but it does give an insight to what can be achieved with a few components and most of all it is a fun project, CW stations will be heard with ease and SSB stations will also be resolved once tuned in correctly (this does take practice). Many broadcast stations can be heard (international ones too).

COMPONENTS

The coil L1 was wound using 32 SWG enamelled copper wire. The former is 21mm OD plastic overflow pipe. L1c is 35 turns close wound. L1b is 8 turns next to ground end of L1c. L1a is 7 turns wound over L1c ground end (see photograph).

If polycon capacitors used; L1c should be 40 turns and both gangs of polycon capacitor should be wired in parallel for bandset capacitor (tuning range will be slightly reduced).

Headphones; use ear pipette type and wire both halves in series to obtain 40 ohms.

A metal chassis/ curry tin should be used for the construction of the set to eliminate hand capacity effects.

Tr1 BC108	C8 50pF variable capacitor	C11 220nF
Tr2 BF981, BF966 etc.	C1 1nF	C12 100nF
RFC1 22mH or greater	C2 10uF	C13 10nF
T1 LT44 push pull amp transformer (the blue one)	C3 10nF	R1 150K
LED 1 standard red or green LED	C4 22nF	R2 150K
C7 500pF variable capacitor	C5 100uF	R3 47K
	C6 100nF	R4 330 Ohm
	C9 10nF	R5 1K
	C10 390pF	VR1 2K2 Lin pot
		VR21 47K Lin pot

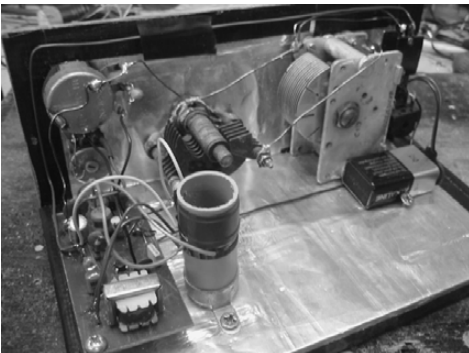

RF Detectors – Which Diode is Best?

Alan Rowe M0PUB, 12 The Knapps, Semington, Trowbridge. BA14 6JG

Simple diode detectors are commonly used for measuring the amplitude of an RF signal. They appear in AM radios (including crystal sets), RF probes, Power/SWR meters, field strength meters and many other circuits. I have been toying with a few ideas for a new power/SWR meter for a while now, and started thinking about a cheap and simple way to measure the forward and reflected RF power, which would allow me to measure levels from QRO right down to QRPp.

One challenge with simple diode RF detectors is that a forward-biased diode has an exponential I/V characteristic, which makes the diode detector highly non-linear at low RF power levels. For example, silicon diodes require a nominal forward voltage of 0.6 – 0.7V before they are considered to be fully conducting. Therefore if the input RF level is much below 0.6V peak (about 4mW into 50 Ohms) the measured output drops away very quickly.

If you want an RF detector which can measure lower levels of RF (for example in the earlier stages of a transmit chain) then you need a more sensitive detector. The directional coupler in my power/SWR meter provides a sample of the RF signal which is less than a hundredth of the input power, so I also needed a more sensitive detector if I wanted to measure QRPp levels. Logarithmic RF detector chips are readily available, and a number of designs have been published which use such devices to achieve wide dynamic range measurement of RF power ... a great idea, but this may be over-complex (and unnecessarily expensive) for some applications.

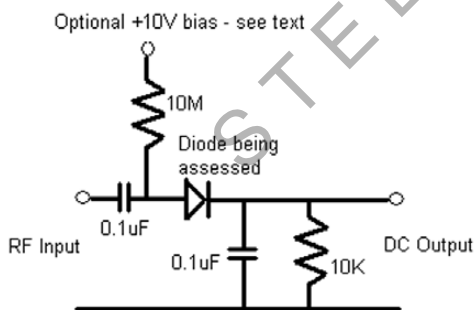

Fig.1.

The output load of 10K was intended to be representative of the impedance presented by a moving-coil meter and associated series resistor (based on a few designs of power meter which I found in various sources). See later for some measurements from a higher impedance circuit.

I started off by measuring the DC output from the detector at various (low) RF input levels using the homebrewer's favourite, the 1N4148 small signal diode, as D1. I didn't expect terribly good results, because as noted above silicon diodes need a high forward voltage

A quick scan of the internet for clues on the most sensitive form of simple RF detector confirmed that germanium or Schottky diodes are better than silicon diodes in this application. But which is best, and how much difference does it really make? So in the spirit of Amateur investigation I built a very basic form of diode RF detector and tried it with a few different types of diode. The detector which I built is shown in Figure 1.

before they start to conduct. However, the 1N4148 established the benchmark that I wanted to improve upon.

For comparison, I repeated the measurements for a 1N5711 Schottky diode, and an OA79 germanium diode. Of course, I could have used different Schottky and germanium diodes, but these were in my junk box. I haven't tried this, but I would expect other diodes of similar technology to give broadly similar results.

I was just starting on these tests when I had the pleasure of visiting Friedrichshafen Hamfest, and there was a trader there selling Hewlett Packard 'zero bias' diodes (part number HSMS-2850). Hoping that 'zero bias' also meant lower forward voltage drop, I bought a few to play with.

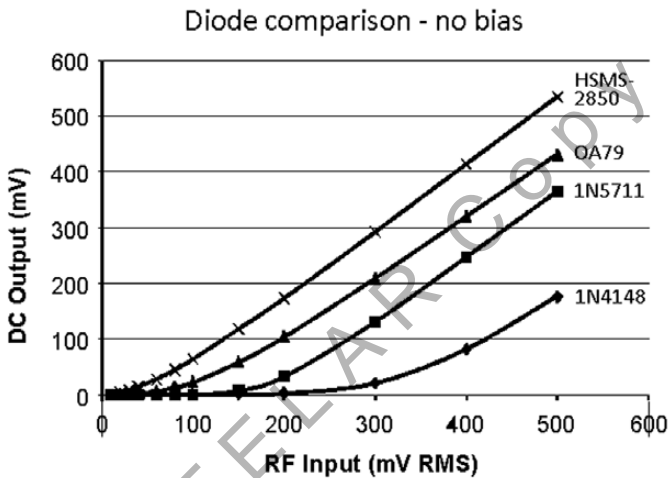

Fig.2.

The results are shown in Figure 2, and confirm that the basic silicon diode was the least linear (and produced least DC output) at low signal levels. The Schottky diode was much better than the basic silicon diode, but for the particular devices I tested the germanium diode was better still. However, as its name implies, the zero-bias diode was the clear winner in this particular test.

All of the plots in Figure 2 were taken with no additional forward bias on the diodes: only the voltage provided by the RF signal. I also repeated all of the measurements with a small DC bias applied to the diodes, and this improved the response for all three 'conventional' diode types, but made very little difference to the results for the zero-bias diode. Figure 3 shows the results with 1uA of forward quiescent current through the diodes, but please note that the plots show values AFTER the constant output voltage due to the bias current is subtracted again.

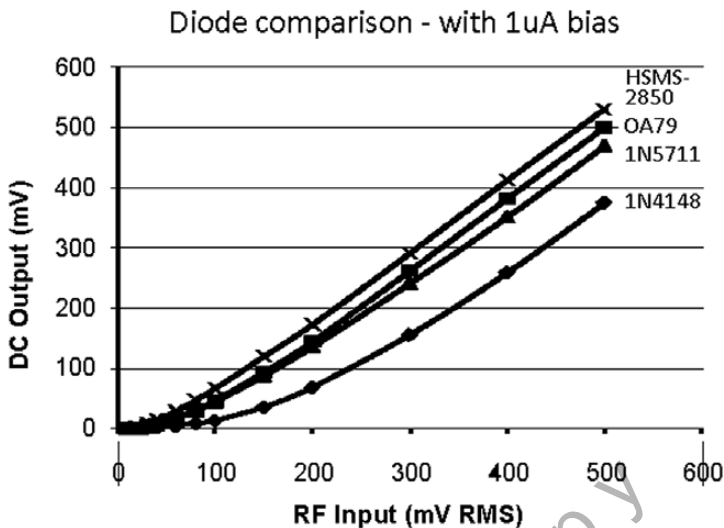

Fig.3.

(I also tried 5uA of bias current and this gave a very slight further improvement for the germanium diode, but otherwise had little effect.)

Of course, diode characteristics are also temperature dependent. All of my measurements were taken at about 20 degrees centigrade: I haven't taken any detailed measurements at other temperatures yet.

As noted earlier, the preceding measurements were taken with a 10K output load to represent the situation in my proposed power meter circuit. But what happens if the output impedance is much higher? The circuit of Figure 4 is commonly used in RF probes, so I measured the two best candidates from the previous tests (the OA79 and the HSMS-2850) in this circuit as well.

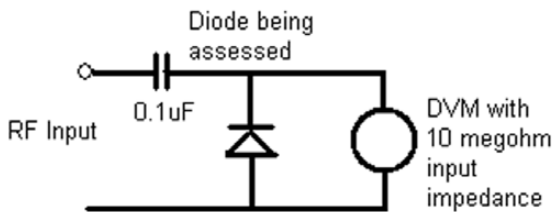

Fig.4.

As expected, both the OA79 and the HSMS-2850 produced more DC output at low RF levels in this higher-impedance circuit. However, I was surprised to find that the measurements for both types of diode were virtually identical. In fact, any differences in the figures could easily be down to measurement tolerances.

Since the circuit topology differs from Figure 1, as well as the output load, I did a quick 'sanity test' by re-measuring the OA79 in the circuit of Figure 4 but with the output load

reduced to 10K. This gave identical results to the values from the previous circuit (within measurement tolerance), which was a good sign.

Of course, this is nowhere near a conclusive test, but for the limited test cases which I tried, it seems that:

- 1) For lower impedance output loads (in the region of 10K), the zero-bias diodes show a clear advantage for measuring low-level RF signals
- 2) If you can't easily obtain a zero-bias diode, then a germanium diode also works well in such circuits, especially if you apply a micro-amp or two of forward bias.
- 3) To detect really low RF levels (down to about 20mV RMS) the best option is to design for a high output load – ideally around 10M. In that case it seems that the humble germanium diode is hard to beat.

For a quick and easy upgrade to many existing RF detector circuits, the zero-power diodes seem very attractive. Farnell stock the HSMS-2850 (but note that it is a surface-mount device), or keep your eyes open at the bigger rallies.

TDA7052 (SPRAT142) single ended output

John Dryden, G4DSN

Regarding the Sprat article on the TDA 7052A, I have been using these amplifiers for a number of years and can confirm that they are excellent devices. I have never had a stability problem with them. One point regarding having to isolate the jack socket. I assume this would be for headphone applications. There is a missing current limiter built in that allows at least 100 mA to be drawn from either speaker output to ground. This is specifically for single ended headphone applications. No need to isolate the headphone jack.

A Tip from Trevor Trudgeon, G0ENZ

I am a reader of Practical Wireless and a GQRP member. I notice that projects use what I think is called dead bug construction. I read somewhere that you stick pieces of circuit board on to a blank PCB to form lands to solder to. Usually when I get a idea it's already been suggested, but just in case it hasn't I thought I would mention it. In my wood working tool box I have a set of plug cutters. There are 5 in a set and you can usually buy them from a market or ebay etc for 3 or 4 pounds. The plug cutters are hollow drills. They will cut out circular lands in 5 different sizes, which are neat and could be stuck on. Also if you use them in a drill press, you can remove a copper polo shape leaving the land in place and separated from the copper plain. If a larger separation ring is needed, just put the next size down in and take another bite. You can also make neat capacitors by using double sided board, I haven't tried making a capacitor, but it seems it might work.

USING THE BITX VER3 ON 12M (AND OTHER BANDS)

Nigel Flatman, G0EBQ, 2 Deben Valley Drive, Kesgrave, Ipswich. IP5 7FB

As well as the better known Hendricks kit, the BITX is also available in kit form as the "Version 3" from Fusion Radio of India, via Ebay. Both are different and equally good; the Hendricks design is more sophisticated, puts out more power and comes with an exhaustive manual whereas the VER3 is closer to the original concept and cheaper, and comes either as a complete kit or just with the board and a few components, which allows the constructor to source the rest from their junk box. The toroids, IRF510, 2N3904, LM386, and input coils are all available from Club Sales and everything else from JAB. Whilst it has no instructions, Leonard KC0WOX has produced a superb set (1) which should be read along with the original article (2).

The VER3 does lend itself to easy modification, because there is plenty of room on the board. Since the band pass filter coils are interchangeable with commercial Toko ones, the band pass and tx filters can easily be modified in line with the data given on the QRP Club website, or the new equivalent range that George introduced in the Spring Sprat, and the only fiddly part is to get the VFO where you want it; a counter is pretty well essential here.

My 12m version uses a 15.36MHz IF and VFO running 9.530 to 9.630MHz; with the values shown it covers a little over at each edge, using a vintage Hammarlund variable with all but one vane removed. With the specified polystyrene capacitors, which do make a difference, stability is close to that of my crystal oscillator despite the relatively high frequency. The crystal filter capacitors will need scaling if using different IFs for other bands, to retain the correct filter response; reduce the capacitance by the % increase in frequency.

The PA gives about 4-5W out at 24MHz without any alterations. I initially encountered instability, but cured this by adding a low value resistor at the IRF510 source. Use the minimum necessary, I needed 4.7ohm. These are the values I used for 12M- BFO - I originally scaled down the number of turns on the series coil but then found that I needed 60pf to tune the BFO, so I suggest that you stick to the original values.

CRYSTAL FILTER - with a 15.32MHz IF use 2 x 56p and 1 x 68p.

BAND PASS FILTERS -I used Toko KANK 3335 with 33p in parallel and 2.2p coupling, but using the club equivalents with the values shown in George's article will be equally suitable.

TX LOW PAS FILTERS - 7t on T50/6 each for L2/L3, with 2 x 120p and 1 x 270p.

VFO - substitute 68p for the 220p and 390 x 2 for the 560p capacitors; use Philips 1% polystyrene for best stability. Start with 32 turns on T50/6 for L4 though this may need adjustment. I needed an additional 10p in parallel with the coil (not the trimmer) to resonate. It took me a long time to get the VFO right so be patient!

All components including the Philips capacitors are available in the UK from Club Sales or JAB, with the exception of the crystals which are available from Mouser in the States. I would be willing to obtain a batch for UK/EU constructors as long as I cover my costs, so if anyone is interested please let me know at nigel.flatman@mypostoffice.co. Estimate a price of about £5 for a set of 5 if demand is sufficient. 15.36MHz crystals would be a good choice also for a 15m rig with a 5.8mhz VFO. 12 is still quiet but can only get better- it can however suddenly come to life and I worked 4Z and SV9 in the first couple of days.

References

1. golddredgervideo.com/KC0WOX/bitxver3new/new manual and golddredgervideo.com/KC0WOX/bitxver3new/linear
2. phonestack.com/farhan/bitx

FISHY BUSINESS

Ryan Pike, G5CL, The Old Coach House, Aylesbury, HP17 8SH

I was very taken by the design of WIREX in fitting a small Rx board into an empty Tuna can but thought that in the true spirit of QRP, that this could be expanded upon in a slightly eccentric way (after all I do have a 'fish' based surname and this is SPRAT!).

Having recently completed a Kilton transmitter from Walford Electronics, I found the board was sufficiently small enough to fit in to a can of sardines with a small modification at one end to house a switch for two crystals. Thus after the contents were consumed on toast for tea, a fishy transmitter to compliment the Tuna receiver, was built. The phono plugs for Power and Antenna are fitted on the side with connections on the reverse of the board.

Strangely, I have also found that Tim's Brent TCVR will also fit in to a can of John West kipper/herring fillets (contents removed first) for another novelty, and if you have an even smaller transmitter like a ONER or Pixie, then with a bit of shoe horning these will fit into a standard can of Tesco anchovies.



In creating this bizarre project, I owe a huge debt of thanks to Ken G8BEQ and Tim G3PCJ for the support they gave me in building these items. However, it would be nice if someone could come up with a novel corned beef ATU design as I am getting a little fed up of oily fish now....

(PS. Please if you try this at home, be very careful of the razor like edges to the thin tin cans)

QRO (and QRP) 50-Ohm Radio-Frequency Power Attenuators

Dave Penny, G3PEN, davepenny3pen@yahoo.co.uk.

Most references to attenuator design provide information only for “QRP” power ratings - typically, 1 to 2 watts input maximum. However, it is sometimes very useful to have an attenuator that can cope with considerable power input, for a variety of purposes.

Amongst these are:

- a) reducing the power output of a Tx directly into an aerial, or into another equipment eg a transverter.
- b) making RF measurements of Tx power, while using a low-power meter.
- c) buffering the Tx from the aerial, while tuning-up or testing a new aerial design.
- d) giving accurate figures for changes in received signals, when the “other end” is playing with aeriels.

Regarding (a) above, I have used a 6dB attenuator with a Tx that could not be easily reduced in output power, to allow operation on Top Band. This value of attenuator reduces a 100W Tx to 25W, which is appropriate for the top end of the band.

Similarly, a 10dB attenuator allows me to claim QRP status on SSB! (I don't have to switch out the attenuator on receive, as on the low bands my Rx has enough gain in hand, but some form of auto switching on Tx/Rx may be necessary on the higher-frequency bands.)

For (c) above, a 4dB (eg 1dB + 3dB) attenuator between Tx and ATU/aerial will always keep the SWR into the Tx at or below 2:1. The attenuator is switched out of circuit when an apparently suitable low SWR is achieved, after which the ATU is finally adjusted for the required real SWR.

For (d), it is possible to use low-power attenuators, but if you have to answer the other station quickly, it is a nuisance to have to keep switching the attenuator out of circuit - and if you forget, it will be “goodbye!” to a possibly expensive item.

As far as practical attenuator designs are concerned, I have found that unit values above 10db - 12dB are not worthwhile, as stray capacity and inductance start to become significant, relative to the resistive values being used. If higher values are required, it is much better to use two or more lower-value attenuators in series. This has the advantage that the first one will have to be rated for the Tx output, but the second attenuator need only be rated in power to accept the output from the first unit.

For instance, when using three 3-dB units in tandem with a 100W Tx, the first will have to dissipate 50W, the second 25W and the third only 12.5W (nominally, at least!). Add a 1dB unit at the front, and the dissipations are 20W in the 1dB unit, and 40W, 20W and 10W in the 3dB units, giving 10W output.

For precise-value attenuators, with a load of 1:1 SWR, the following (rounded) figures apply, where R_a is the input resistor (to earth) of a Pi network, R_b is the series resistor, and R_c is the output resistor. R_l is the load resistance. The figures show the relative amounts of power dissipated in each element.

Table 1.

Loss	Ra	Rb	Rc	Rl
1dB	.06	.1	.05	.79
2dB	.12	.18	.07	.63
3dB	.17	.24	.09	.50
4dB	.225	.285	.09	.40
5dB	.28	.32	.08	.32
6dB	.33	.33	.09	.25
7dB	.38	.34	.08	.20
10dB	.52	.33	.05	.10
12dB	.60	.30	.04	.06

For the perfect attenuator/load, the power in Ra + Rb + Rc + Rl = 1.

It can be seen that it is possible to build most values of attenuator with a considerable reduction of resistor wattage rating for Rc, perhaps saving on component costs or space. However, the cost saving is probably negligible, especially as it is easier to buy a larger number of resistors of one value than a few of each value and wattage. Also, I have found that having a unit that can be used either way round without harm saves a lot of grief, so my designs are all bi-directional in power terms.

The above figures are for a perfect attenuator looking into a perfect match. For practical purposes, it is best to assume that the attenuator will see up to a 2:1 mismatch, either lower or higher than the nominal figure. Allowing for this, the following (rounded) figures apply:

Table 2.

Nominal Loss	Max. Power Dissipation			Power in Rl	Actual Loss dB
	Ra	Rb	Rc		
1dB	.1	.2	.1	.76	1.2
2dB	.2	.3	.15	.59	2.3
3dB	.24	.4	.2	.46	3.4
6dB	.4	.5	.15	.225	6.5
7dB	.44	.45	.14	.178	7.5
10dB	.6	.4	.1	.1	10.5
12dB	.7	.35	.1	.056	12.5

These are the dissipation figures that I used for some practical designs of power attenuator. As you can see, the power totals no longer add up to 100%, as each value now depends on whether the load is below or above 50 ohms, and the worst-case figure is given in each case. For a symmetrical design, the dissipation value for Rc should be the same as Ra. Note: The loss is always greater, and the same, for equally mismatched loads (in SWR terms) below and above the nominal impedance of the attenuator.

For reference, relative to the “SWR = 1:1” figures above, the reduction in safe loading to 66% occurs approximately as below, for loads higher than 50 ohms:

1dB - 1.7:1 SWR 3dB - 2:1 SWR 7dB - 3.4:1 SWR 10dB - 6.5:1 SWR.

For loads below 50 ohms, the 66% point occurs approximately at:

1dB - 1.7:1 SWR 3dB - 2.5:1 SWR 7dB and 10dB - at least 10:1 SWR.

I ended up building a range of attenuators using the above data, using the 1dB, 3dB, 6dB, 7dB and 10dB designs, as this seemed to give the maximum flexibility in use.

My own construction of attenuators (in 1999) to the above data used 3W-rating Metal-oxide resistors from Electromail, to produce the units shown in Table 4, below. It appears that Electromail is/was an arm of RadioSpares, who can still supply the nominally identical items today. At present, I have not been able to determine whether they still have the same RF characteristics as the ones that I used.

However, the attenuators that I made, as detailed below and using Type-UHF sockets, were checked for SWR, and were all below 1.3:1 SWR at 145MHz, except for the 1dB unit, which was 1.9:1. All units were better than 1.1:1 below 30MHz. The slight inductive nature of the metal-oxide resistors doesn't seem to have a significant effect on performance below about 400MHz. Capacitance effects are probably more serious in this respect.

Note: Tests on these resistors, using a variable DC input to individual components, resulted in the resistors glowing red-hot with about 15-times wattage overload, losing all their paint and colour. However, on cooling down, the resistance values were identical to before the power test. In a typical attenuator construction, I would expect the soldered connections to melt long before such temperatures were reached! Don't use metal-film or carbon resistors for these attenuators - they can't take the overloads that may occur at times.

Double-sided PCB was used for the construction, with a well-ventilated "box" layout to allow maximum heat dissipation. The ratings given below are approximate limits for 1:1 and 2:1 SWRs, but this does depend on your construction methods. Short lead lengths to the PCB, well anchored (soldered) to the PCB with the remainder of the normal lead-length, and with reasonable spacing to adjacent components, will help in this respect.

Incidentally, the Pi configuration was chosen for these attenuators because it makes for a simpler construction, with the input and output resistors both anchored firmly to large "earthy" ground-planes, aiding the heat dissipation.

Various combinations of resistors (all in parallel) were used to achieve resultants near to the theoretical figures. You can work out your own requirements, no doubt! Using the figures below, lower rated units could be built by using 2W or 1W resistors instead.

Table 3.

Theoretical Resistance Values (in ohms):

Attenuation	Ra = Rc	Rb
1dB	869.6	5.769
2dB	436.2	11.61
3dB	292.4	17.6
4dB	221.0	23.8

5dB	178.6	30.4
6dB	150.5	37.35
7dB	130.7	44.8
8dB	116.0	52.8
9dB	105.0	61.6
10dB	96.25	71.15
12dB	83.53	93.25

Table 4.

Practical Resistance Values (in ohms) - all 3W rating:

Attenuation & Approx. Input Wattage	Ra and Rc	Rb
1dB @ 70W - 140W	$3 \times 2700 + 27K = 870$	$4 \times 27 + 39 = 5.754$
3dB @ 90W - 150W	$9 \times 2700 + 10k = 291.3$	$12 \times 220 + 470 = 17.64$
3dB @ 40W - 70W	$4 \times 1200 + 10k = 291.3$	$5 \times 100 + 150 = 17.65$
3dB @ 25W - 40W	$2 \times 680 + 2200 = 289.9$	$3 \times 56 + 330 = 17.67$
3dB @ 13W - 22W	$470 + 820 = 298.8$	$33 + 39 = 17.88$
6dB @ 50W - 70W	$8 \times 1200 = 150$	$8 \times 330 + 390 = 37.3$
6dB @ 10W - 13W	$270 + 330 = 148.5$	$68 + 82 = 37.17$
7dB @ 55W - 70W	$9 \times 1200 = 133.3$	$8 \times 390 + 560 = 44.85$
7dB @ 19W - 23W	$3 \times 390 = 130$	$3 \times 150 + 470 = 45.19$
10dB @ 60W - 70W	$12 \times 1200 + 2700 = 96.43$	$8 \times 560 = 70$
10dB @ 35W - 40W	$7 \times 680 = 97.14$	$4 \times 330 + 470 = 70.18$
10dB @ 12W - 15W	$2 \times 270 + 330 = 95.8$	$120 + 180 = 72$
10dB @ 7W - 9W	$150 + 270 = 96.43$	$68 = 68$

The first wattage figure above is for a worst-case 2:1 SWR, the second is for a 1:1 SWR, provided the heat-sinking and ventilation is adequate.

Queries may be addressed to me at davepenny3pen@yahoo.co.uk. I do have the various equations for determining the input Z and dissipations for any value of attenuator, including both Pi and T, and any value of SWR, but I think they are a bit too long for this article!

ANTENTOP

Igor Grigorov, VA3ZNW, a Russian born member of the G QRP Club now living in Canada has for some years run ANTENTOP; a free e-magazine devoted to amateur radio antennas with some radio construction items. Articles from all the issues of the magazine can be found in PDF format at www.antentop.org and in printed book form via www.lulu.com. ANTENTOP categories include an interesting variety of antennas and other sections including homebrew receivers and transmitters and QRP projects. All are downloadable free of charge although there is an opportunity to make a donation to support the website.

Free Retro- AM Kit Draw

Sponsored by David Searle, ZL3DWS

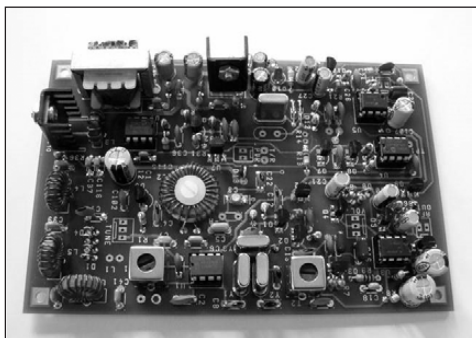

Dave Benson, K1SWL, of Small Wonders Lab has produced a retro-kit; a compact 80m AM Transceiver. Tunable Receiver- 50 kHz, selectable, varicap-tuned
 4 kHz receiver crystal filter
 Crystal-controlled Transmit- 3880 and 3885 kHz supplied
 Transmitter output power: 2.5W carrier/ 8W peak

To celebrate the 100th member joining the SWL Retro 75 Yahoo group <http://groups.yahoo.com/group/SWLRetros75/>; ZL3DWS has one Smallwonderlabs.com Retro 75 80m AM transceiver to give away. If like David, you couldn't afford a Codar AT5 way back when, here's your chance to try AM QRP today with a super little AM rig. To enter the supervised draw, simply send a blank email to ZL3DWS@nzart.org.nz before July 31st, 2010. In the subject line you MUST enter: **SWLRetro75** plus your **Call Sign**. The winner will be announced in the next issue of SPRAT.

The 10K Spectrum 10mm coil range

Graham Firth G3MFJ

Further to George's piece in the last issue about these, we now have a fuller range available:

L uH	Spectrum type	TOKO equiv	Coil form colour
1.2	1u2H	3335	Pink
1.7	-	4612	White
2.6	2u6LC	1509	Pale blue
5.3	5u3L	-	Yellow
11	11u0L	-	Dark blue
45	45u0L	3333	Red
90	90u0L		Pale red

The suffix L is Low Z secondary, H is high Z. 2u6LC has a capacitor as it is intended as a 10.7MHz IF transformer, but this can be removed. A copy of the full data sheet can be downloaded from the club website – look on the Technical page. To purchase – please look at the sales page.

The New G-QRP Limerick Sudden Kit

Graham Firth G3MFJ



We are pleased to announce the first of a new range of kits for the club. This is a re-think of the original design by George G3RJV, this time back to using a VFO to cover the full band, and has other minor improvements to the circuitry. The kit uses a new method of construction, based on “Manhattan” design, but called Limerick. With this method, developed

by Rex, WIREX, (who lives in Limerick, Maine), the pads are actually etched on the board, and the interconnections between them are PCB tracks, hidden under the solder masking. No “through hole” connections are used, although “through hole” components are used, neither are there any coils to wind, as manufactured (Spectrum) coils are used. The kit includes all components, the complete case, knobs and even a PP3 battery. All you need to supply is a soldering iron and solder, and a few simple hand tools. The iron should be of a reasonable size, as the case is made by soldering the parts together, and a low power iron may not be “man” enough. The completed receiver needs a reasonable antenna, and a pair of walkman style earphones,

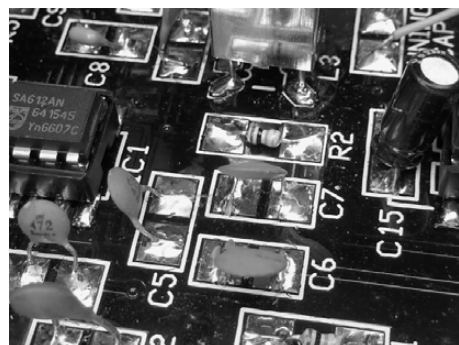
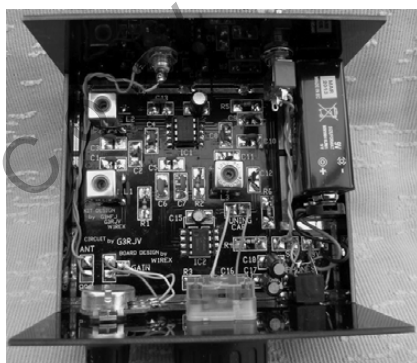

although the audio stage will drive a small loudspeaker in a quiet room. The kit is now available for 80m, 40m and 20m, and we are looking at versions for 160m and 30m. The kit costs £34 plus postage - £2 (UK), £3 (Eu), or £4 (DX), and should be ordered from club sales – see the back page. Please ensure that you specify the band you require! You can

download the full manual from the club website. We are planning that the second kit will be a matching crystal controlled CW TX.

Antennas Anecdotes Awards

Colin Turner G3VTT

30 Marsh Crescent, High Halstow, Rochester, Kent ME3 8TJ
G3vtt@aol.com

In SPRAT 141 I asked any GQRP members how they fed the 84 foot long wire and counterpoise usually called the 'W3EDP'. I've used one recently /MM and had some wonderful results on 80m using the Electcraft K1 and its internal tuner. My thanks to all of you who contacted me, (unfortunately I have had to edit some of the letters because of space in our tiny magazine), and if you are thinking about such an antenna you may care to bear these comments in mind. No pictures this time but an interesting read I hope.

'At this QTH my shack is a shelf in a cupboard in the spare bedroom. I can't get an RF earth and can't run a centre fed antenna. My w3edp runs up through the cupboard and above the ceiling joists. The wire then feeds out behind the fascia board to an insulator mounted on a bracket screwed to the house wall next to the bedroom. The far end is attached to an insulator at the top of an old quarter wave CB vertical. As the garden isn't long enough to get the full length in, the last six feet or so then comes down to a piece of string which is anchored to a screw on a fence panel! This is real amateur radio! The 17 ft counterpoise comes down through the cupboard and then is hidden under the edge of the skirting board - at right angles to the antenna run. The antenna and counterpoise are terminated at a panel at the back of my cupboard and then fed though a short length of 400 ohm ribbon from the balanced output terminals of my SEM TRANZMATCH. Does it work? Using the TS530S I can match the antenna on all bands and I do get contacts with it. I stay mainly on 80 and rarely use more than 20 watts of CW often turning down the 530 to 5 watts output. 73 David G4HYY'

You will have to be up early in the morning David and around 3525/3560 to work me but your comments are most welcome!

'I have been playing with the W3EDP antenna for the past year. The first thing I noticed was that the total length of wire ($84.5+17.5=102$ ft.) was the same as the G5RV. The second was that the original W3EDP was fed with a balanced line. So, I put up a flat top 102ft. long and fed 17.5 ft from one end with about 25ft. of home-made open ladder line of about 500 ohm. The ladder line is connected directly to the ATU in the shack. The antenna tunes up easily on all bands 80-10m. An added advantage is that the feed line break-out is right above the shack. 73/72, Tom W6JHQ'.

Thanks Tom. I guess that is an off centre fed variation.

'Hi Colin, with interest I read the recent AAA. I've been using a W3EDP since we moved to near Bonn at JO30KP. I've got my shack in my bedroom on the 1st floor. The radial is under my bed and causes some RF in the flat, but that's not too critical at QRP levels. The longer wire is put through a small hole in the wooden frame of the window, and then runs up a 5m fibre-pole and from there horizontally across a small garden at about 7 or 8m above the grass. It's picked up at the remote corner by 5m of bamboo strung to the fence with cable-ties. The remaining metres of wire slope down along the fence. The wire points SW and on the higher frequencies I recognize a kind of directivity of the antenna. The directivity has proved to be a hampering factor during the latest 6m-Es-season. Here in DL we're limited to 25W ERP on 6m, and hence I'm going to

set up a separate antenna for that band this year. Tuning is done the lazy way by inserting a 1:4 between the W3EDP's wires and the IC-703-ATU. For sure there are losses, for sure it's far from being the perfect solution but as sure it's very comfortable and enables working 80-6 with only one stealth wire and without problems with landlord or neighbours. I can match it to the transceiver with my ZM (design G3WQW, SPRAT#84), 73 Tom DM4EA'

Thanks Tom for your excellent e-mail to me and good luck on 80 – 6m.

'Thank you for the W3EDP article. As requested I've included details of my experiences with this 1928 design. Between July 86 and January 89 I contacted 36 countries 21 of which were with 1-5 watts QRP. Another w3edp was used between May 2008 and October 2009 giving 38 contacts but only 8 of these were QRP. In both cases the counterpoises used were 17ft, 6.5ft and 2.5ft. The earlier W3EDP (tuner?) box was metal and outside. The link being coax to the rig indoors. The later W3EDP box was wooden and is now rebuilt into a metal box. I intend to use this indoors and will feed the box with a single coax carrying both counterpoise and antenna. Both W3EDP's were tapped on the coil which enabled most bands to be used with an SWR being between 1.1 and 1.5. The antenna height is 20ft to 25ft bent into L shape and my garden is 26ft wide 39ft long. The box contains the atu which is a 21 turn coil 2" former tapped at 21/18/7/5 turns with a 250pf.v/capacitor as your diagram in Sprat. Also the 3 turn link coil goes to the rig with no balun. This was based on the article in Short Wave Magazine dated August 1981. This shows a second variable capacitor on the rig link side which I have not used. Hope this info helps. 72/73 Ted G4TTY'

Thanks Ted. This seems a conventional arrangement which works well for you.

'Here in York I do not have the room quite apart from neighbours so I have been using a W3EDP design but not as original. The operating position is in a wooden shed with a plastic ventilator grid in end walls. The aerial is made of Teflon coated stranded wire which come out of the grill 6 ft above ground and goes straight up for a further 7ft, i.e. to 13 ft above ground. It then goes away to a pole in corner of garden which is 18 ft high. That takes up the whole 84 ft. Also coming out of the grill are 2 more wires to the right and left. In the shed these 2 wires go immediately to a change over switch. One wire is 17 ft long and the other 6.5 ft. These are suspended down the sides of the shed about 6 inches below the edge of the roof, i.e. about 6 ft above ground. The 84 ft wire and the output of the switch are connected to 4 ft of 450 twin feeder. This feeder then is connected either to the balanced side of a QRP one-coil Z-match or via a choke balun to a Z11 auto ATU. I find that I can match the rig to aerial on bands 3.5, 7, 14, 18, 21, 24 and 28 with either ATU. This is using the 17 ft wire counterpoise. I have found no obvious advantage in using the shorter length. I have a ground spike attached to some 150 ft of wire just under the gravel and connecting to that gives no improvement. Unfortunately the noise level on 80m here is usually S7-9. Performance I would rate as moderate; better than a slightly shorter OCF aerial I tried the spring Meanwhile, many thanks for taking over AAA.73Frank, G4IEY /CTIHPF'

Thanks Frank, another conventional arrangement.

'I read with interest in the current SPRAT the article on the W3EDP Antenna. My (non-QRP) friend G4GTX comments about the antenna. "I am always surprised at how well the W3EDP with "standard" counterpoise does on 80/40m and also 18 MHz. One thing I found out recently is that the W3EDP when used on 14 MHz gives a low SWR without any

*atu. I have also found that it never seems to give rise to RF in the shack. I have heard many qso's where some sort of RF feedback is getting into a mic and causing distortion on voice peaks and have never had a report of this with the W3EDP. It seems a very "tame" aerial and gives a 1:1 SWR quite easily with the atu and has never been tricky to tune as some random lengths of wire have been in the past. For what it is and for what it does, I think it's an excellent design."*72/3 John G3NUA

Some interesting remarks about the lack of RF feedback and John went on in a further e-mail to talk of his own arrangement.

My version of the EDP extends from the upstairs shack at the back of the house to a pole at the left-hand end of the garden, where it goes through quite a sharp bend. The last 30 feet or so then double back up the LH side of the garden towards the house. The counterpoise, approximately 60' long, drops vertically from the window and goes round the right-hand side of the house a few inches above ground level and then along the bottom of the RH boundary fence. The antenna is used mostly on Top Band when I have a tapped loading coil between the counterpoise and the homebrew L-match ATU. I tune the ATU and select the counterpoise loading coil tap to give minimum SWR, usually about 1:1, but I haven't yet incorporated any means of monitoring the current in the antenna or the counterpoise. This arrangement enables me to keep a weekly sked with G4GTX about 17 miles north He also uses a W3EDP but with a commercial ATU, earth rod and 132' counterpoise. Though these contacts are mostly non-QRP we sometimes use our FT817s on SSB at 5 watts perfectly satisfactorily. I first used an HB Z-match ATU with the EDP but found that the L-match produced a better signal. For 80m I omit the loading coil and connect the counterpoise directly to the ATU' Thanks again John.

'Regarding the W3EDP - two pieces of wire and an ATU provide a multiband antenna that can be made to work on all HF bands from 3.5 to 28 MHz. 1.8 MHz is even possible with a separate series-tuned ATU arrangement (see SPRAT 121 p 26 & fig.1). It does not require an earth, and therefore lends itself to situations where the shack is remote from ground, centre feeding is impractical, and it is desirable that the antenna should be inconspicuous. However getting it to work properly is all down to installing and tuning it right, and some important points need to be understood. The W3EDP Antenna is an off-centre fed doublet with a top length of $84 + 17 = 101$ ft (compare 102 ft for the G5RV). It is important not to think of the 17 ft section as a "counterpoise"; it is part of the radiating element and should be installed as such. Indeed there is scope for ingenuity in turning the 17 ft section to advantage as a radiator. The feed point is unbalanced and the feed impedance is reactive and varies from band to band. An ATU is essential, and the above-mentioned diagram shows a parallel-tuned inductive-link-coupled ATU (for very good reason, as will appear below). In operation the ATU tuned circuit is adjusted to tune out the reactive component of the feed impedance, thereby bringing the antenna into resonance at the transmit frequency. At resonance it becomes a tuned RF transformer, with the link coupling being adjusted to achieve an impedance match predictable manner, it is essential to appreciate that when transmitting, high even dangerous RF voltages can be developed on the tuned circuit due to the feed point being unbalanced and close to one end of the antenna (remember that the ends of a dipole or doublet antenna are voltage maxima). Any ohmic or highly capacitive between the antenna feed point and the rig introduced by the ATU will make the rig and everything connected to it live to RF as it has (inadvertently) become part of the antenna. This may disturb the operation of the rig

and will certainly disturb the antenna tuning; as with extra conductors attached to it (or if earthed) the antenna is no longer a true W3EDP. Transformer isolation of the feed point is therefore essential, and the tuned RF transformer is the simplest and most efficient way of providing it. Once adjusted, the parallel-tuned inductive-link-coupled ATU is exactly that, making it optimally suited to the W3EDP Antenna. Furthermore common-mode coupling between the antenna and rig is confined to the stray capacitance between the tuned and link coils and this can be kept to a minimum in the ATU construction. Other ATU types will either lack the essential feed point isolation (e.g. T-match) or will lack the ability to efficiently match highly reactive impedances (e.g. Z-match), sometimes both. I am therefore convinced that the parallel-tuned inductive-link-coupled ATU is the ONLY ATU type suitable for the W3EDP antenna and that the diagram on p 29 of SPRAT 141 is absolutely correct in this respect. However I am unaware of any commercially available parallel-tuned inductive-link-coupled ATUs. And the following guidance is therefore offered to assist the home constructor.

1. It is doubtful that effective coverage of all HF bands 80-10 m will be obtained with a single ATU. Two units covering 3.5-10 MHz and 14-30 MHz are envisaged.
2. The tuned coil should be tapped at intervals along its length (8 to 12 or more) to provide a range of options for connecting the tuning capacitor and the aerial wire. This maximises the range of impedance and frequency over which the ATU will work.
3. Variable link coupling can be most conveniently implemented by connecting a variable capacitor in series with a fixed link coil. This works just as well as moving or rotating the link coil.
4. A generous clearance (1/4 " min) should be allowed between the tuned and link coils to minimise the stray capacitance between them. Chris G3RJT

My thanks again to all of you who wrote in with your experiences. There are no pretty pictures this time apart from the usual cat but please take a look at 'W3EDP' on Google.

Awards: Our congratulations to:

Ryan G5CL for obtaining '100 Countries QRP DXCC Award'

Derek G3ZNR for obtaining '150 DXCC QRP Countries'

Gert PA0RKT for '10 Two Way QRP QSO's'



72 for now and have a good Summer G3VTT

ZL Membership News

Tony G4WIF

Mike Sheffield ZL1ABS has indicated that he wishes to retire from his long serving role as NZ GQRP representative. Our new representative is Phil Tarrant ZL2NJ, P.O.Box 55, Wanganui 4540, New Zealand. Ph 06 344 7182, cellphone 027 474 2143 ph or txt. Account details :- Kiwi Bank -Account name:- "PHIL GQRP", Account No 38 9003 01861315 02 (refer to the club website for current email details).

Our grateful thanks to Mike Sheffield ZL1ABS for being the perfect representative for our club over so many years and many thanks to Phil Tarrant ZL2NJ for stepping forward.

COMMUNICATIONS AND CONTESTS

**Peter Barville G3XJS, Felucca, Pinesfield Lane, Trottscliffe,
West Malling, Kent ME19 5EN. E-mail g3xjs@gqrp.co.uk**

The very promising start to the year, with good HF propagation, has sadly not lasted and band conditions have recently been very poor indeed. I have just returned from a sailing holiday in Turkey where my efforts to work /MM with QRP CW on 20m proved hard going. I'm hoping to make better antenna arrangements for the next trip.

WINTER SPORTS

My sincere apologies to Eric **GOOTE** for omitting his log from the WS entries listed in SPRAT142. He used 5W from a Tim Walford kit, homebrew antenna matching unit and doublet antenna for his 21 80m QSOs.

CHELMSLEY TROPHY 2009

This event reflects results during the whole year, and requires a degree of effort in order to put together an entry. It also requires a careful read-through of the rule requirements (to be found in every Members Handbook). Whilst the rules are not very demanding, it is important they are followed in order that all entrants have a level playing field. As with all events, correctly submitted entries also help hugely when it comes to adjudication. My thanks to Peter **G3JFS**, Ryan **G5CL**, Mike **GM0OAA**, Carl **GW0VSW** and Anthony **K8ZT** for their entries. Anthony's log was an impressive one, with plenty of QSOs and Dx (145 DXCC) throughout the year, but unfortunately his antennas do not meet the requirements as set out in the rules. Although I prefer to take a relaxed view wherever possible, I have no option but to discount Anthony's log for award purposes, but very much hope he will not be discouraged from entering Chelmsley (and other events) again in the future.

For **G5CL** it was his first Chelmsley entry, and a fine one too. Ryan worked 48 2-way QRP band slots, a total of 147 band slots with the best QSO being one with VK4TJ on 20m. His antenna throughout was an end-fed 66ft wire varying between 3m and 9.5m above ground, and the log shows CW contacts on 80/40/30/20/17/15&10m. **GW0VSW** used CW, SSB and PSK31 to raise a total of 77 DXCC with an indoor 'Crown' wire loop or SRC X80 vertical. Carl had 66 2-way QRP QSOs, with 22 different DXCC countries.

The entry from **GM0OAA** was interesting as it was in two parts – one operating as GM0OAA and one as I5/GM0OAA. Mike worked 45 DXCC (8 2-way QRP) from the home station, and 33 DXCC (5 2-way QRP) from Italy. His antenna at home is 15m of wire stretched between 2 bay windows half way up the side of a three storey Glasgow tenement building. It is about 20 ft above street level and 20 ft below the top of the roof! Mike worked into the USA and Canada several times, which is quite remarkable considering the antenna is on the east-facing side of the building! There is a picture of the antenna on his QRZ.COM entry which is well worth looking at. Under the circumstances Mike, a wonderful effort. Peter **G3JFS** always presents impressive logs, and his Chelmsley entry entry is no different. He used CW and SSB to work a total 77 DXCC and 271 band slots. His antenna was a 120ft end-fed matched with a Smartuner. His

outstanding QSO of the year was with K5D on Desecheo Island on 80 metre cw. Peter had tried in vain to raise the DxPedition on the HF bands but, to his amazement, they came back to him on 80m after just a couple of calls. Unsure whether they had his call sign correct, he called and worked them again!

As they say in so many TV contests these days, it was almost “too close to call”! Each log had its own particular virtue, but Peter has just pipped the others to the post. I would like to offer **G3JFS** my congratulations on being the 2009 Chelmsley Trophy winner. In addition, both **GW0VSW** and **G5CL** deserve runner-up certificates for their achievements throughout the year and dedication to QRP.

CZEBRIS 2010

Thanks to Karel **OK1AIJ** I am able to show the complete results this year. Combining the OK/OM results with those from the UK produces: **OK1DMZ** 123 points, **GM4XQJ** 99 points, **OK1DEC** 70 points, **G4FDC** 62 points, **OK1HCG** 44 points, **OK1DKR** 36 points, **SP6IFN** 30 points, **OK1AIJ** 13 points, and **OK1MYA** 4 points. Congratulations to all, and the relevant certificates will be on their way.

INTERNATIONAL QRP DAY

I'm not sure whether you will see this in time, but please don't forget this important annual QRP event. The rules are in the Members Handbook. If SPRAT doesn't reach you in time, then you may still be able to submit an entry – assuming you were active on the bands with QRP on that day.

QRP IN THE COUNTRY

A final reminder about Tim Walford's new “real radio field day” to be held on 18th July. Homebrew radio is the theme - further details from “walfor@globalnet.co.uk”.

EUCW BULLETIN 1/2010

If you would like a copy of this bulletin, dated 2nd April 2010, please drop me a line.

The deadline for inclusion in the next issue is the beginning of August, but in the meantime I hope you have plenty of QRP FUN on the bands, whatever the conditions.

72 de QRPeter

<i>MEMBERS ADS - MEMBERS ADS - MEMBERS ADS - MEMBERS ADS - MEMBERS ADS</i>
--

WANTED: Radiovision Hambander Receiver. Working or non-working considered. Also Command Receiver for Top Band. Please contact: Rev. A. Heath, G4GDR, 227 Windrush, Highworth, Swindon. Wilts. SN6 7EB. Tel: 01793-762970

FOR SALE: Versa Tuner-II £50 + postage, Antenna Multi-Ranger 9 £10 + postage, Antenna AMPRO 160 7 feet £10 + postage or collect, Antenna 2m half-wave £10 + post, Albrecht 10m Mutlimode [10m plus 25 to 30MHz) £60 + postage.
Tom M3EHA, 01606 - 597342

Peter Linsley, G3PDL / SV0XBM/9, SK by George Dobbs, G3RJV.



I have known Peter for a long time. I thought 50 years but in my last phone call with him about 2 weeks before he died, he told me in that definite Peter manner, “49 years in June”. He was born in Cleethorpes, Lincolnshire, in July 1943; the same place as me and three weeks before me. We did not attend any of the same schools but met when we were both working as lowly assistants in the laboratories of a paint company on the Humber bank. We were both, for differing reasons, taking a work break between school and college days.

Peter had a keen interest in amateur radio from his childhood and was an active member of the ISWL during his schooldays, winning several CW classes in their listening contests. About the time we met he just became G3PDL. I was engaged in electronic construction, mainly audio equipment, but he urged me to turn to amateur radio and take the RAE. He also taught

me Morse in our lunch breaks and thus I became G3RJV.

Peter trained as a physics teacher. After a short spell of teaching in Grimsby, Peter began work at a school in the Lincolnshire market town of Caistor. He continued to work at the same school for over 30 years, becoming Head of Science. He was a real part of the local community. It was impossible to walk around this small town with Peter without repeated calls of “Hello Sir!” It seemed that every tradesman Peter used, from builders to motor mechanics, was an ex-pupil.

During our early working years and a period when I moved around quite a lot our contact became more intermittent, although we met on the air from time to time. I remember his slick CW operating from his legendary, and much modified, KW2000. On a return visit to my native Lincolnshire in the 1970s, I called upon Peter and talked him into joining the G QRP Club which I had helped to found a few years earlier. Later he was to become the treasurer of the club; an office he held for over 20 years. Peter was also President of FOC in 1997. We shared an interest in building our own equipment; swapping ideas and circuits. His all-band contest grade transceiver, built on circuit boards with tracks engraved using a wood turner’s gouge, took a long time to build, performed beautifully, and weighed too much.

16 years ago Peter met Diane when she served him a pint of beer in one of her sister Janet’s pubs. They obviously made a deep impression on one another because I married them two years later in the local church. These were to be the happiest years of his life with a loving wife who was a fine cook (Peter demolished good food) and supported his interest in amateur radio. Some 5 years ago Peter and Diane moved to Crete to live and help run a family holiday letting business. They designed and had built their beautiful house in Vamos near Chania. Then to everyone’s dismay in October of last year Peter was diagnosed with cancer. Jo-Anna and I were staying with them at the time. After bravely battling the disease, Peter died peacefully with Diane by his side in the home they had designed together.

I travelled to Crete to take Peter’s funeral service. The church was packed with local friends from Crete and family and friends who had travelled from the U.K. I had discussed and planned the nature of the funeral with Peter himself. He would have been pleased with the positive nature of the day and the obvious and loving support for Diane.

I remember Peter as a good companion, a real gentleman and a superb radio amateur. Amateur radio and the lives of his family and many friends will be the less for his passing.

MEMBERS' NEWS

by Chris Page, G4BUE

Highcroft Farmhouse, Gay Street, Pulborough,
West Sussex RH20 2HJ.
E-mail: <chris@g4bue.com>



Congratulations to the Bath Buildathon event and DVD on being awarded the Kenwood Trophy for outstanding contribution to amateur radio training at the RSGB's AGM in April. All the 'BB' crew received certificates of merit: Mike, **G3VTO**; Lewis, **G4YTN**, Steve, **G0FUW** (mentors/elders); Robin, **G3TKF**, and Julian, **G3UHK**, (film crew) and Tim, **G3PCJ**, (kit supplier and 'industry' rep in the DVD). Congratulations also to **W1REX** and **W4QO** who, with recent Silent Key **K4TWJ**, were inducted into the QRP Hall of Fame at **FDIM 2010** at the Dayton Hamvention. **WIREX** is well known to kit builders, he runs **QRP.me** and is famous for the production of the Tuna Tin range of amateur radio kits. Rex is a well known elmer and champion of QRP. **W4QO** has been associated with **QRP ARCI** for many years serving as President, Webmaster and **FDIM** Chairman. Congratulations also to **WJ2VN** and **NM0S** who were among the winners in the Homebrew Contest.



QRP meets QRO! **DM4EA** and **DL2BQD** had the pleasure of staying in London for a week in March and visited the radio stations at Bletchley Park and on board *HMS Belfast*. Tom and Dieter express their cordial thanks to the amateurs who made the visit possible. The photograph on the left is the statue of Alan Turing, a mathematician, logician, cryptanalyst and computer scientist who worked for the Government Code and Cypher School at Bletchley Park, and who, for a time, was head of Hut 8, the section responsible for German naval cryptanalysis.

G3XBM says **G4IKZ** is using a Vine Antennas 10m Moxon two element beam and if you are keen on 10m, and want some gain from a low profile beam, this may be of interest, see <http://www.vinecom.co.uk/10m_moxon.htm>. **G5CL** reports **G3ICO** QSO'd **OK1IF** on two-way QRP on 6 March and says **OK1IF** is looking for UK amateurs for skeds on 5260kHz, <ok1if@volny.cz>. Also on 6 March, **WJ2V** was impressed with **VU2LID** who copied Preston's 500mW WSPR signal over a distance of 8562 miles. **G0KYA** is interested in HF propagation and has short-path propagation forecast charts for each band at <<http://www.infotechcomms.net/propcharts/>>. On 9 March **RV3GM** QSO'd **FG/F6AUS** on 30m with his K2 and 230 feet long-wire antenna.

"AM is dead. Long live AM", says **ZL3DWS**, who suggest members needing an 80m transceiver which weighs less than the mic for an FT-200, should look at the 'Retro75' from Small Wonder Labs in the USA, <<http://smallwonderlabs.com/Retro-75.htm>>. David says, "At \$70 [about £50] it seems great value. Who is going to be the first in the UK to get on the air with one?". If you own, or are interested in, the Clansman PRC-320, **G7JWR** has started a new group at <<http://groups.yahoo.com/group/prc320/?yguid=3D370654844>>. **DL2BQD** reports there were about 50 amateurs and XYLs from DL, HB9, OE who met in Waldsassen for the 2010 DL G-QRP Meeting. There were presentations on various topics from SDR radio to antennas for QRP/P use, and displays of homemade rigs. Dieter says there was also time for a chat and a good glass of beer and the ladies had an additional opportunity to visit a moor area near OK land. On the right are (l to r) G-QRP Club members Fred, **DJ3KK**, and Bernd, **DK3WX**, with Wolfgang, **DL2JWL**, and Andreas, **DL4JAL**, who is a specialist for programming and measuring techniques.



The picture at the top of the next page shows Bernd's experimenter's board with a 10m version of Stephen Weber's basic ATS idea, ex-

tended with a PIC and some more little bells and whistles.

G3YMC made 71 QSOs in the RSGB's Commonwealth (BERU) Contest in March, including 9G, VP2M, 7Q, 9J, J8, VK2, 3B9, 5X and 5H, and **GM4YLN** made 81 QRP QSOs with his 5W. **7L3DNX**, Secretary of JARL QRP Club, announces the '2010 World Wide QRP Contest' for nine days from 12 June (including International QRP Day on 17 June) when JA QRP stations will be looking for QSOs with overseas stations. Between 29 April and 30 June special QRP stations **8J1P**, **8J4P** and **8J6P** will be QRV. More details on the JARL website <<http://www.jaqr.org/>> under 'contests' (use the Google translate facility). **RV3GM** announces the World QRP Activity Day (WQAD) on 17 June promoted by Radio Club 72 with prizes and trophies, details at <<http://www.club72.su/qrpday.html>>. The Club also promotes QRP World rating tables: **OM3CUG** is top of the QRP DXCC Table with 308/304 worked/confirmed and **GM3OXX** is top of the Two-way QRP Countries Table with 115/115 - well done Igor and George.

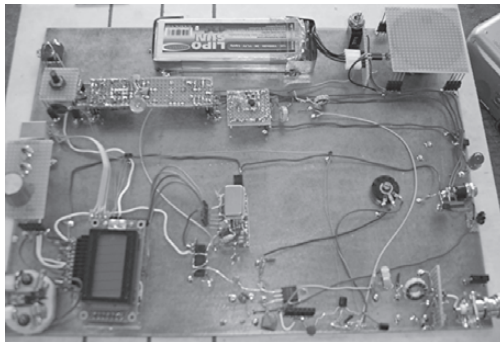

AA1TJ tried 'milliwatt' on 20m CW on 15 March with his Bellringer transceiver reduced to 10mW to an end-fed wire, and after a 109 report from **KK4IP**, Mike received 559 from **F5NBX** followed by another 559 from **FM5LD**. **EA3FHC** QSO'd **8P6BX** on two-way QRP (both 4W) on 15m on 19 March. **GM3OXX** had a great start to the day on 25 March when he went on 20m at 0700z and heard **A33A** calling CQ with no takers. After receiving the usual 599 report, George joined the pile-up for **ZK3OU** and after 15 minutes got another 599 report, giving him a 'new one'. George says you don't have to go to the pub for a happy hour because on 17 April between 0821 and 0914z he worked **ST2AR**, **ZS6BQI**, **BA8AG** and **A92GE** on 17m!

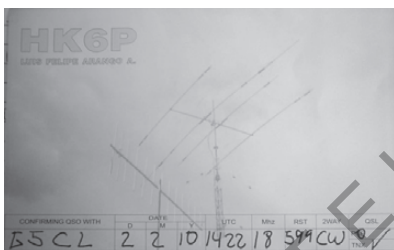

G5CL received this QSL from **HK6P**, which resulted from calling CQ on 17m with 5W. Ryan also logged **V8SSS** on 20m, **CX7CO** on 10m and **NP3CW** on 17m. On 30 March he QSO'd **ZA1FD** for his last European country after 25 years. **IK0IXI** received a QSL from **VK7GK** who Fabio QSO'd with 2W on 20m CW using his homebrewed KTR-1 transceiver and Windom antenna. **G3XBM**'s main interest this period has been 10m QRP WSPR, with his best DX with 5W and the halo being a report from **CX2ABP**. Roger has also continued work on 500kHz but no new DX to report and is thinking about 136kHz WSPR next winter. **ZL4TE** is still 'playing' with data modes

and entered the KJGM VK/ZL RTTY Sprint Contest on 24 April using QRP with his **ZLIPETE** call. Pete made eight QSOs (seven ZLs and **VK3TDX** on 40m).

On 24 May **M0MJH** worked HA, 9A, S5, LZ, E7, YU, CT, IV and YT on 6m with his FT-817 and 5W SSB to a tri-band colinear. Mark says, "Think what I might be able to achieve if I was able to put up a proper antenna for 6m!". **G3JNB** hooked up a dipole to his FT-817 for 6m as the band started opening for the 2010 season, and with 4W at the feed point, Victor's initial QSOs took him around Europe and, as he got the hang of it, down to **CN8KD**. **G0KYA** put up a 6m half-dipole in his loft but found his 132 feet OCF dipole was actually better and his parallel-fed dipoles was also about as good. Steve suggests checking 6m on your normal HF antennas as you often get a surprise.

G30OU is building a three band (2, 4 and 6m) valve transverter to match his Heathkit SB line-up. Only one band (6m) is working so far but the picture above shows the project so far. Bob made all the metalwork using basic tools. It uses an IF of 28-30MHz and the front panel will match his collection of Heathkit SB-line units, some of which have been re-engineered for today's band conditions. The Matching PSU will allow all three transverters to run on standby for hot switching during contests etc. The five rear panel eight-pin connectors interface with three HF drivers, one daisy chains to another future transverter for UHF and one daisy chains to optional future linears. The circuit is almost all valves but Bob had consid-



erable problems getting enough frequency stability with valve overtone oscillators and modern miniature crystals, so he used two JFET J310 overtone oscillators, one for simplex, one for repeater, with an E180F tuned buffer. The RX is RF stage 6CW4, mixer E180F, and the TX is balanced mixer 2 x E180F, driver 5763 and PA 7984. The IF is 28-30MHz, 2V IF input in 50 ohms will result in 25W saturated band output but the PA must be limited to 10-15W output on a 420V supply to ensure adequate linearity on SSB. The 7984 is not well known in the UK as it was developed in the USA for Motorola mobile radios up to 175MHz, but is now reasonably cheap. The pictures on the right show Bob's dual Z-Match made several years ago (also matching the Heathkit line) covering 2-160m and used with a stub loaded HF dipole with narrow spaced (0.9 inch) open wire feeders.

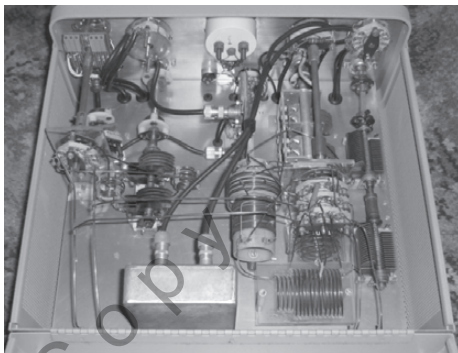

Ireland's "biggest and best ever QRP gathering" was held on 11 April on the shores of Lough Erne in Co Fermanagh, Northern Ireland reports **MI5MTC**. It was attended by **G3MFJ** with the G-QRP stall and **G3RJV** who gave the afternoon talk. **MIKTA** had a stall for his home-built kits and **EI6IZ** had a stall of Elecraft kits. **GM4VKI** and others manned a Club stand at the Magnum Rally in Irvine on 9 May when 22 members signed in. Roy plans to have another club stand at the Galashiels Rally on 17 October. **G4HZJ** reports that **G6YBC** has taken over Kanga Products and will be attending the Red Rose Festival on 7 June. Dennis's new web-site is <www.kanga-products.co.uk>. After three years in Italy and a total of 10 years in Europe, **N2CQR** (**MØHBR** and **CU2JL**) will be moving back to the USA in early July and live in Virginia, near Washington DC. Bill says the *SolderSmoke* podcast will continue from the new location.



MØNDE reports the Dover Construction Club hosted by **G3ROO** recently welcomed **N2CQR** of *Soldersmoke* fame to the club while Bill was in London. The picture left shows Bill at the key of Ian's B2 spy set. Nigel is working on a replica Paraset, and Merv, **MØMIN**, and Peter, **MØPKH**, are doing the same. They have the top metal work drilled and fitted with variable capacitors, valve bases and have wound the main coils. Next they are hunting for the resistors and especially need to source the chokes or parts to construct the chokes. They plan to have a local net running their sets and perhaps act as foxes to be tracked down, reminiscent of spies being traced in wartime! Tony, **G4XBW**, is so far is refusing to build a Paraset with them, and continues with a very nice antenna switching unit with power indicator. Nigel is also working on an RSGB spectrum analyser.

G3XBM reports **DK7FC** was again testing on 8.97kHz in March using an ERP of under 2mW with a kite supported vertical antenna. This time he was received by stations in several European countries including two stations in the UK and one in Italy. **MØBMU** copied the transmission on a very simple receiver consisting of a small loop antenna into a high dynamic range preamp and Spectrum Lab sound card based VLF receiver. Roger has put a copy of Jim's latest preamp on the 9kHz page on his website <<http://sites.google.com/site/g3xbmqrp/Home/10khz>>.

He says, "The 33kms band (yes it's that wavelength) is showing real promise for ionospheric DX and although the TX antenna, TX power and matching coils are a challenge to get even a QRPP ERP signal, the RX side is possible by almost anyone. Several people in the UK have now applied for NoVs for the 8.97kHz band and are awaiting clearance. No longer is this just a band for experimenting with 'earth mode' through the ground conduction communication or links using pure induction, even though this is also fascinating; now people are seriously talking about when the first amateur signal will be heard across the Atlantic on 8.97kHz. Quite amazing stuff".

G3XIZ built the **G4JNT** up-converter (pictured right) which enables Chris to transmit WSPR signals using his home built (simple) 500kHz TX (pictured below). He says most operators use 'black-box TXs' for this mode, which only requires connections from the PC to the TX mic and PTT sockets, but it was slightly more involved to get his homebrew TX going but it works a treat. Chris is approaching his 1100th QSO on 500kHz and says quite a few PA stations are now QRV on the band

Using 2.5W SSB from his FT-817 to a dipole just 12 feet high, **GD1MIP** QSO'd a W1 in Massachusetts at the end of March, followed by a Serbia station. Andy says, "Cheered me up it did especially as there was a contest on and the bands were full of comments about hundreds of watts, big beams and mega-priced TX setups". **LA1TPA** QSO'd **YI9PSE** on 8 April using his K3 on 17m with a 27MHz 5/8 vertical! Mads now has 72/67 QRP SSB DXCC. The 9A QRP Club now has the callsign **9A0QRP** for use with a maximum of 5W CW.

G14FLG half-jokingly calls his shack 'The Oliver Heaviside Laboratory' partly because this British genius and pioneer of radio and electronics, whose achievements easily rank alongside those of Hertz and Maxwell, has never been adequately recognised. Ken says, "The other reason is that it is a suitably grandiose name for a radio station consisting of a table full of part-baked radio projects in the corner of our back bedroom, with a piece of wire strung down to the garden fence for an antenna".

He has recently become interested in SOTA and experimenting with antennas for portable use. Having achieved a Chaser Certificate, endorsed 'All CW All QRP', Ken is now trying to get fit so he can climb some mountains and go for an Activator Award. He says a bit of altitude certainly helps with QRP contacts as, using just 500mW, he had a summit-to-summit QSO with **HASTI/P** on a mountain in Hungary.

Pictured left is **YU7AE's** 'new toy', an all-band/modes DDS 10W transceiver. Kare tested it in the EA QRP Contest and made about 50 QSOs. He has also made a two-way QRP QSO with **KH6MB**, and with **ZL2AGY** on 20m CW LP with it. On 1/2 May he tested his PRC320 (battery operated) /P (see picture below) portable and made about 30 CW QSOs with a ten feet



whip antenna and four 33 feet radials. Kare says the PRC320 is a very good rig for portable use and has a good 250Hz CW filter. He has also built a QRP transceiver (see pictures top of next page), a **DC4KU** and **YO5AT** design with 9MHz IF, and MMiC (mar6, mar8) in the IF stage; the PA stage is in a separate box with the LPF filter but is not finished sufficiently for it to be photographed.

G4AKC has been QRV on 20m, mainly pedestrian mobile but some bicycle, and on 22 April had a two-way QSO with **ZL2JBR** whilst using only solar power from his pedestrian mobile two

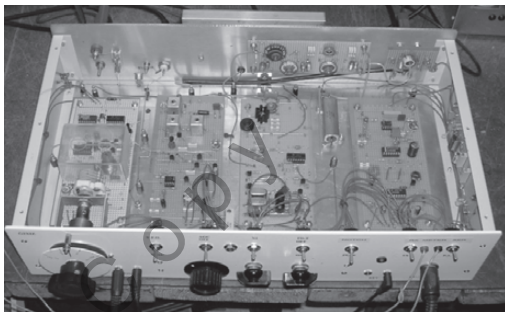
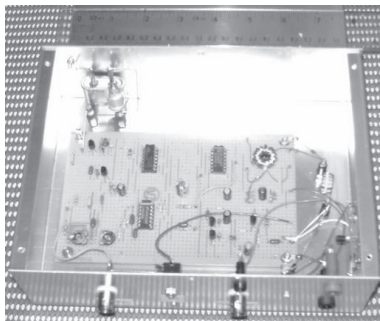

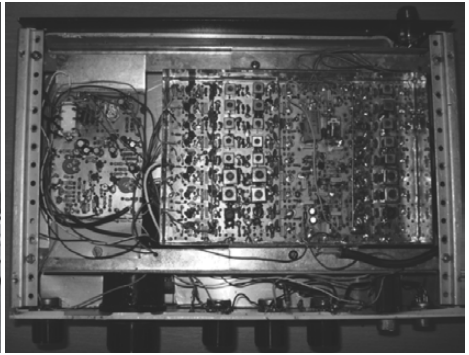
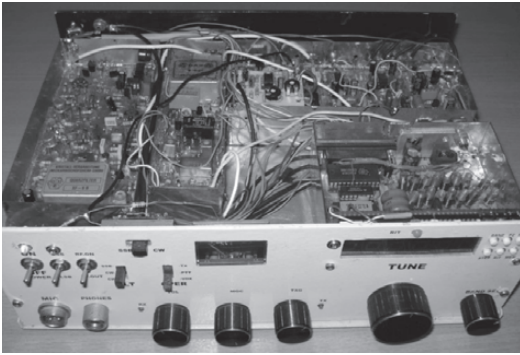

wheel trolley (without the use of any batteries) on 20m SSB receiving a 5/3 report, as witnessed by Lee, **GØDBE**. Dave was using his Mizuho MX-14S 20m 2W CW/SSB handheld transceiver powered by a double solar panel mounted on the trolley. The antenna was a full size quarter-wave mounted on the trolley and the ground was a home made tuned frame GTU without radials. He says, "It was sunny and fortunately it remained sunny throughout the QSO as if the sun disappears then so does my transmit and receive! I operated from Lytham and I was very close to the sea water. Dave has added some pictures of his solar powered trolley at <www.qrz.com/db/g4akc> under 'latest developments'. **G3XBM** has added a page on his website <<http://sites.google.com/site/g3xbmqrp/Home/portable>> about pedestrian portable HF DXing based on his experiences using QRP SSB on the higher HF bands. Also included is a table of counterpoise lengths from **KQ6XA** that appeared some years ago on the Miracle Whip Yahoo group. **KI6SN** reports the June 2010 free edition of *WorldRadio Online* magazine is available at <<http://www.worldradiomagazine.com/>>.

New member **OH5JL** built the ATS3B. I pictured right last winter which he says is, "Maybe the funnest QRP rig which is real fun to operate". Tuomas's best QSO with it, using his two element vertical array for 30m, was at the beginning of April with **ZL1BYZ** on 30m LP, a distance of about 14,571 miles which is his longest distance ever (see QSL above). Another new project was a ZM-2 ATU kit by Emtech which was Tuomas says was fun to build and is very good value for the money.

That clears the files again. My thanks to everyone who has contributed, this column can only exist with your support. Have a good summer and do let me know how it goes for you, what you build, what you put up and what you work, plus any other news, views, gossip and opinions about QRP and, of course, your photographs - by 20 August please.



Czech Army Morse Keys

These are one of the most pleasant hand keys to use and are extremely well made. Complete with the original lead and plug. Over 50 years' old but still in factory wrapping like new.

Add this to your collection, or use it for everyday relaxed straight key CW. £30 UK, £35 EU and £37.50 DX incl P&P

Mike Bowthorpe G0CVZ, 2 The Lawns, Peterborough PE4 6BG Pay via Paypal using g6sgg@bowthorpe.org or send cheque with your call, name and address.

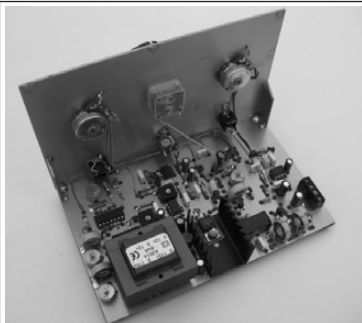

Four new kits

Trull - MW or HF regen TRF for beginners

Willett - Simple DC receiver for 20, 40 & 80m

Washford - xtal CW TX for 20, 40 & 80m

Chimside - AM TCVR for any single band to 6m

Knapp, Knole, Kilton, Brendon, Fivehead,
Midney/Kingsdon, AMU etc all still available.

Visit www.users.globalnet.co.uk/~walfor

Walford Electronics

Upton Bridge Farm, Long Sutton, Langport, Somerset TA10 9NJ

www.jabdog.com

Now in Excess of 11,000 products stocked and ready to ship

Crystals select any 20 from list below for just £6

3.579545MHz, 3.6864MHz, 4.19304MHz, 6MHz, 8.863256MHz, 9.8304MHz,
10MHz, 11.52MHz, 12MHz, 16MHz, 25MHz or 39MHz

Classic Style Chicken Head Black Pointer Knobs

KNO-122 Buy 10-for £3 or Buy 25-for £7

1N4002 Diodes Buy 100-for £1.50 == 1N4148 Diode Buy 100-for £1.50

1N5406 Diodes Buy 100-for £4 == 1N5819 Buy 100-for £9

BC546 NPN Transistors Buy 100-for £3 == 2N3904 Buy 100-for £5

2N7000 FET Buy 10-for £1 == 2N3819 FET Buy 10-for £3

2N3055 Power Tran Buy 10-for £4 == BC107 Buy 10-for £2

BD139 Transistor Buy 10-for £3 == BF245B FET Buy 10-for £2

BFR79 Transistor Buy 10-for £4 == BFR40 Buy 10-for £2

BFW92 Transistor Buy 10-for £5 == 2N5400 Buy 10-for £2

2N3773 buy 10-for £10 == BC147 Buy 10-for £1

BSY95a Buy 10-for £3 == IRF510 Buy 10-for £6

ZTX108 Buy 10-for £1.50 == IRF630 Power FET Buy 10-for £5

ZTX653 Buy 10-for £3 == ZTX751 Buy 10-for £3

Have you tried our priority bi-Monthly loyalty offers list?

Available on subscription at £6 for 6 months or send a SSAE for a sample copy.

JAB Electronic Components. PO Box 5774. Birmingham B44 8PJ

e-mail jabdog@blueyonder.co.uk www.jabdog.com

Mail order: - Post please add **£2.60** Free over **£25** UK DX Post see website
Cheque or Postal Orders (Payable to P A Thomas please). MasterCard or VISA also welcome.

X-LOCK 2 - VFO STABILISER KIT

The latest version of our highly successful VFO stabiliser kit! The X-Lock connects to your VFO to compensate for long term drift. Measuring only 36mm x 61mm, the X-Lock continuously monitors the VFO frequency and computes a correction signal to compensate for drift. Opto-coupled low noise analogue circuitry produces an exceptionally clean DC tuning voltage for the VFO correction varactor. Other features include adjustable post tuning control delay of 1-15 seconds, power-on auto centring, RIT memory, automatic unlock during tuning, input and Lock states indicated by a dual

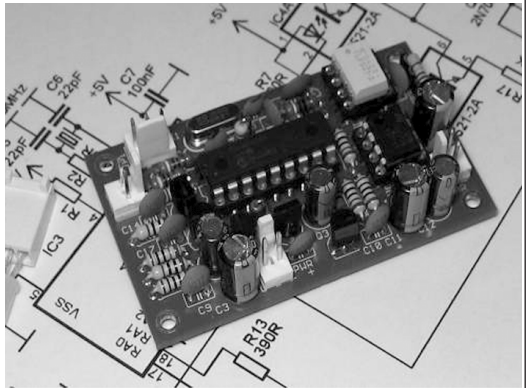

colour LED which can be mounted on off the main PCB, on board regulators, nominal +12v supply.



The X-Lock kit comprises double sided, high quality silk screened PCB, pre-programmed processor, all components, connectors, IC sockets and a comprehensive step by step instruction manual. Just add 12v and a VFO!



X-Lock VFO Stabiliser kit £22.95 inc. VAT (£19.53 ex VAT), P&P UK £1.76, EC £2.94, Rest of World £6.00 Order on-line or by post.

www.cumbriadesigns.co.uk, email: sales@cumbriadesigns.co.uk

Tel: +44 (0)7973 894450

PLEASE NOTE OUR NEW ADDRESS!

Cumbria Designs, 16 Chestnut Close, Culgaith, PENRITH, Cumbria, CA10 1QX, UK

Bowood Electronics Ltd

Suppliers of electronic components

Batteries, Buzzers, Capacitors, Connectors, Diodes, Cases, Ferrites, Fuses, Heatshrink, IC's, Inverters, LED's, PCB, Potentiometers, Power Supplies, Presets, Rectifiers, Relays, Resistors, Soldering Equipment, Stripboard, Switches, Test Meters, Thermistors, Thyristors, Tools, Transistors, Triacs, ...

Catalogue available NOW Please send 60p stamp or visit our website.

Website: <http://www.bowood-electronics.co.uk>

email: sales@bowood-electronics.co.uk



Mail order only - NOTE NEW ADDRESS

**Unit 10, Boythorpe Business Park, Dock Walk,
Chesterfield, Derbys, S40 2QR
UK Telephone/Fax: 01246 200222**

SDR-Kits.net - Software Defined Radio kits

New!! PA0KLT Low Noise Synthesizer kit with LCD display uses high performance **Si570 IC** covers **3.5 MHz–940 MHz**. Suitable for Softrock and home brew Local Oscillator Projects - +12dBm Sq-Wave Out with 4:1 Trafo into 50 Ohm drives DBM Mixer or QRP TX.

QRP2000 USB-Controlled Synthesizer kits and **Si570 CMOS and LVDS ICs** stocked

DG8SAQ USB-controlled Vector Network Analyser VNA Kit covers 1 kHz to 1.3GHz as described in QEX Jan/Feb 2009 see www.SDR-kits.net for details

New!! Mitsubishi 175 MHz RF FETs now stocked: RD15HVF1, RD06HVF1, RD00HSV1 also RD16HHF1 16W £4.20, RD06HHF1 6W £3.20 RD00HHS1 0.3W £1.10 - UK postage only £1.00
KB9YIG Softrock SDR Receiver Kits 40M £13.00 and 80M Lite with 3750kHz Xtal only £14.00

Jan Verduyn, 14 Ragleth Grove, Trowbridge, Wilts, BA14 7LE, UK sdrkits@gmail.com

Rig Broken or needs alignment?

Commercial/Homebrew equipment repaired & aligned

Ten-Tec repair specialist, spare parts ordering service available

Adur Communications

13 Dawn Crescent, Upper Beeding, Steyning, West Sussex. 01903 879526

Unadilla baluns & traps - Outbacker Antennas

www.adurcoms.co.uk

AMTOOLS UK

Selected bargains in components, tools, antenna poles, etc.

D9 9M fibre glass telescopic pole, now only £24.50. D6 6M POLE, £12.50.

ADE-1 double balanced smd mixer. (Like SBL-1), 2 FOR £5.50.

Fibre glass spreader set for cobweb, quad, etc. £22.

HZj7 QRP ribbon antenna kit, £14. Springy (Slinky) £2.45.

20pc micro drill bit set £3.50. Eye loupe magnifier (10x mag.) £2.50.

Mini-Circuits HPF-505X-1 mixer, £2.00...Lots more! ...Low mailing charges worldwide.

Visit the AMTOOLS *virtual* department store at www.amtoolsuk.com

72, Les. 00 44 1942 870634.

Amtools UK, 1 Belvedere Avenue, Atherton, MANCHESTER, M46 9LQ

QSL Cards from Nasko - LZ1 YE

LZ1YE has sent me details of some attractive QSL cards including the Club Log.

Members can make their orders by sending samples, explaining what they want to print, and sending the materials: photos, files...etc via e-mail: qsl@qslprint.com or qsl@kz.orbitel.bg or if no internet access via the postal address: Atanas Kolev, P.O.Box 49, 6100 Kazanlak, Bulgaria. Examples of cards and prices can be seen at www.qslprint.com

For people need QSL cards urgently LZ1YE dispatches three days after the payment is made. UK Members can pay via a UK address: Please send your cheque / cash via recorded delivery to: LZ1YE QSP Print service, c/o Melanie Rowe, St. Leonards House, 35 St. Leonards Road, Exeter, EX2 – 4LR, Devon. e-mail: m0mjja@aol.com (make cheques payable to : Melanie Rowe)

Practical Wireless, the magazine that brings you Amateur Radio & so much more...

**Practical
Wireless is
Britain's best
selling Amateur
Radio magazine**

Practical **WIRELESS**

Britain's Best Selling Amateur Radio Magazine



Contents include; George Dobbs G3RJV's long running and ever popular Carrying on the Practical Way series, Amateur Radio News, Products and Rally Information. The magazine also brings you regular reports on all the bands, antennas, historical, technical and feature articles and a comprehensive, fast Book Service.

Available from UK newsagents, by subscription or direct from us

TEL: 0845 803 1979 FAX: 01202 659950 E-MAIL: info@pwpublishing.ltd.uk

Quality, value-for-money hobby radio magazines from PW Publishing Ltd.

PW Publishing Ltd., Arrowsmith Court, Station Approach, Broadstone, Dorset BH18 8PW, UK
web: www.pwpublishing.ltd.uk



Look at 'www.celticpilgrim.com' for Amateur Radio in a Lovely Place

G3RJV has a Wooden Lodge situated in the Dyfi Valley in central Wales close to the Irish Sea and in the Snowdonia National Park. It has been completely refurbished with a large living area, conservatory, double bedroom, twin bedroom and a double bed sofa in the living area. Naturally there is a small amateur radio station with a QRP HF transceiver and a 2m

multimode. An easy to use station in a quiet location.

Look on the webpage above or for leaflet write to G3RJV or email g3rjv@ggrp.co.uk

GQR Club Sales

Graham Firth, G3MFJ, 13 Wynmore Drive, Bramhope, LEEDS. LS16 9DQ

Antenna Handbook – 2 nd edition – members £6.00, non-members £10.00 plus post	} £1.40 (UK);
Radio Projects volume 2 – by Drew Diamond – members £5, non-members £10 plus post	} or £3.40 EU;
Radio Projects volume 3 – by Drew Diamond – members £5, non-members £10 plus post	} or £5.80 DX
Radio Projects volume 4 – by Drew Diamond – members £5, non-members £10 plus post	} <u>per book</u>

6 pole 9MHz SSB crystal filter 2.2kHz @ 6 dB, 500ohm in/out £12 plus post	} £1.30 (UK); £1.50 EU
Polyvaricon capacitors – 2 gang (A = 8 to 140pF, O = 6 to 60pF) c/w shaft ext & mtg screws - £1.20 each	} £2.00p (DX)

Pair LSB/USB carrier crystals HC18U wires - [9MHz ± 1.5kHz] £4 pair	}
MAR-4 RF amplifier - £1.20	} All components

HC49U (wire) crystals for all CW calling freqs – 1.836, 3,560, 7,028, 7,030, 7,040, 10,106, 10,116, 14,060, 18,096, 21,060, 24,906, & 28,060 - £2.00 each	} plus postage
HC49U (wire) crystal for DSB on 40m – 7.159MHz - £2.00 each	} (ANY quantity)

HC49U (wire) crystals – 1.8432MHz, 10.111MHz – 50p each	} £1 (UK),
HC49U (wire) crystals – 3.579MHz, 3.5756MHz, 3.5820MHz, 3.6864MHz, 4.1943MHz, 10.0MHz, 13.50MHz, 32.00MHz – 30p each	} £1.50p EU,
	} £2.00p (DX)

Miniature crystals (watch crystal size – very low power) – 7.030, 10.106, 18.096, 21.060, 24.906 & 28.060 – limited quantities - £2.00 each	} If
Ceramic resonators – 455kHz, 2.0MHz, 3.58MHz, 3.68MHz & 14.30MHz – 50p each	} ordered

Schottky signal diode – 1N5711 low fwd volts for up to vhf/uhf 20p each	} max of 5
Varicap diodes – MVAM109 – 40pF @ 9v, 500pF @ 1v. 50p each	} max of 2
– BB105 – 4.5pF @ 10V, 15pF @ 1V linear range 25p each max 2	} toroids,
	} binders,
	} or

SA602AN - £1.75 (note – I may supply NE or SA, 602 or 612 as available. All are fully interchangeable.)	} filters,
MC1350 - £2.00	} use

PICAXE-08M – as used in Rex's kits – 8pin - £2 each	} that
LM386N-1 - 4 to 15v, 300mW, 8pin DIL - £0.40 each	} postage

LM386M-1 - 4 to 15v, 300mW, 8pin SMD [0.2" (4mm) x 0.25" (5mm)]- £0.35 ea	}
TDA7052A - 4.5 to 18v, 1W 8pin DIL low noise DC vol control – £0.60 each	} If
CA741 op-amps 8pin DIL – 5 for £1	} ordered

TA-7642 Radio IC – direct equivalent of MK484 (& ZN414) – 75p each	} with books
--	--------------

2SC536 transistors (npn) fT - 100MHz, hFE-320, VCBO +40V - 5 for 50p	} add this
--	------------

MPSA92 transistors (pnp) fT - 50MHz, hFE-40, VCBO -300V - 5 for 50p	} postage
---	-----------

2N3904 transistors (npn) fT - 300MHz, hFE-150, VCBO +40V - 10 for 50p	} as they do
---	--------------

2N3906 transistors (pnp) fT - 250MHz, hFE-150, VCBO -40V - 10 for 50p	} do not travel
---	-----------------

2N3819 N channel JFET – 12p each	} well together
----------------------------------	-----------------

BF988A dual gate MOSFETs TO50 package – 20dB @ 800MHz - 50p each	}
IRF510 FETs - £1.00 (NOTE THE PRICE DECREASE!)	} All components

10K 10mm coils (TOKO or equivalent) - see inside this issue – all 75p each	} plus postage
--	----------------

1.2uH – (TOKO 3335) – Spectrum 1u2H Pink	}
1.7uH – (TOKO 4612) – Spectrum 1u7H White	} (ANY quantity)
2.6uH – (TOKO 1509) – Spectrum 2u6LC Pale blue	}
5.3uH – (No direct TOKO equivalent) – Spectrum 5u3L Yellow	} £1 (UK),
11.0uH – (No direct TOKO equivalent) – Spectrum 11u0L Dark blue	} £1.50p EU,
45.0uH – (TOKO 3333) – Spectrum 45u0L Red	} £2.00p (DX)
90.0uH – (No direct TOKO equivalent) – Spectrum 90u0L Pale red	}

Toroid cores – all toroid cores are available as recent ads (no room this time!)

Binders for Sprat - the original 'nylon string' binding type back in stock again! Black with club logo on spine **£3.75 each plus postage** (one: UK – £1.20, EU – £2.00, DX – £2.50. More – add £1, £1.20, £1.50 each)

Sprat-on-CD V4 – 1 to 140 (see Sprat 140) – members price - £4 plus post UK - £1.00, Eu - £1.50, DX - £2.00

Please note - I only have stock of the above items – I do not sell anything else. Anything in previous advertisements and not shown above is out of stock – if it becomes available again – it will be in the next magazine.

Cheques (UK) and payable to **G-QRP Club**. Sorry, but cheques in other currencies are uneconomical to us due to bank exchange charges!

MINIMUM ORDER for cheque or PayPal payments is £5

For orders less than £5 – please use postage stamps (any denomination £1 or less please) - any quantity of stamps is OK, or cash. I can accept cash in GB Pound, or US\$, or euros – but please send securely! You can order via e-mail and pay by PayPal. Use g3mfj @ gqrp.co.uk – pay in GB Pounds and you MUST include your membership number and address please