

PC MAGAZINE



3D PRINTERS

FEATURES**COVER STORY****THE MANY DIMENSIONS OF 3D PRINTING**

3D printing is (or soon will be) everywhere, but it can be tricky to understand. We break down what it is, how it works, and why it's a game-changing technology you need to know about.

THE YEAR OF MAGICAL PRINTING

Think 3D printing has nothing to offer you yet? Think again. Over 365 days, one man saw it improve his home, his family, and himself. Here's how.

THE KING OF 3D PRINTERS

The MakerBot Replicator does not come cheap, but if you want the best 3D printer you can buy right now, this is it.



REVIEWS

Google Chromecast



CONSUMER ELECTRONICS

Google Chromecast

Amazon Fire HD 8 (8GB)

Apple iPhone 6s

HARDWARE

Microsoft Surface Book

Microsoft Surface Pro 4

Acer Chromebase DC221HQ
bwmicz

D-Link AC1900 Wi-Fi USB 3.0
Adapter (DWA-192)

SOFTWARE & APPS

Microsoft Office 2016

Bitdefender Internet
Security 2016

Apple iPhone 6s



Microsoft Surface Book



WHAT'S NEW NOW



DISNEY-THEMED PROSTHETICS MAKE YOUNG PATIENTS HEROES

Open Bionics is using 3D printing to open a realm of mobility—and fun—to children in need.

FAREWELL SILICON?

According to IBM, switching from silicon to carbon nanotube chips could boost performance, help battery life, and more.

HOW CISCO IS TEACHING CLIENTS TO CHILL

See how the Cisco Hyperinnovation Living Labs is preparing for the next wave of connectivity.

VALVE'S MOVIE BRATS: INSIDE THE SOURCE FILMMAKER COMMUNITY

Games and films are fusing more than ever before thanks to a little-known Valve tool—and some players' intense creativity.

TOP GEAR



OPINIONS

DAN COSTA

First Word

READER INPUT

EVAN DASHEVSKY

New Credit Card Chips Mean Innovation, Annoyance

ERIC GREVSTAD

Telecommuting: The Antidote to Rush Hour

TIM BAJARIN

How Mobile OSes Could Drive the Future of Personal Computing



This is a classic example of an unintended consequence of the smartphone.



JOHN C. DVORAK

Last Word

DIGITAL LIFE



GET ORGANIZED

Make Your Job Search Easier

TIPS

Encrypt Data on External Drives

HOW TO

Customize Windows 10

CONNECTED TRAVELER

The Room Service Robots Have Arrived



Why 3D Printing Matters

Trend spotting is all about timing. Earlier this week, I was talking to an editor who works outside tech about the top trends in the industry. I told her about our cover story this month, and she asked if 2016 would be the year that 3D printing goes mainstream. Would consumers start buying printers en masse? Not likely, I told her—most people don't need one, and probably never will. She was too polite to ask, "So why the heck are you putting it on the cover of your magazine?", but her skepticism was obvious.

Then I heard about a Reddit user going by the name NSA_Listbot who claims to have 3D printed a railgun. For those of you not versed on advanced weaponry, railguns use electromagnetic energy instead of gunpowder to fire projectiles at super-high speeds. (NSA_Listbot claimed 560mph.) I was doubtful, but the photos were good enough to get me to click. Soon, NSA_Listbot posted YouTube video of the test shots. The gun was real. Although the weapon isn't completely 3D printed, a lot of its parts are. The 20-pound device runs on six capacitors that produce 1,050 volts; each shot uses 1,800 joules of energy. The gun even uses an Arduino Uno R3 to monitor the charge levels.

This isn't the first or most practical demonstration of 3D printing, but it clearly shows what's possible today because the technology now costs so little. Prosthetic limbs, car parts, tweezers, iPhone cases—if it's plastic, you can print it.

I'd like to say that we've been covering 3D printing since it was invented, but it goes back further than you might expect. In 1981, Hideo

Kodama of the Nagoya Municipal Industrial Research Institute published a paper detailing one of the first additive manufacturing processes. And in 1984 Chuck Hull developed a rapid prototyping machine using stereolithography, dubbed the SLA-1, which is generally acknowledged to have been the first 3D printer. The firm Hull started to commercialize the technology, 3D Systems, has been 3D printing stuff for more than 30 years.

Those systems, of course, often cost \$50,000 or more. Now you can buy a 3D printer for less than one-tenth that. As with most emerging technologies, there's a lot of variation in terms of features, performance, price, and even the specific technology used. Tony Hoffman, our resident 3D printing guru, has tested dozens of units and picked out his favorite to highlight in this issue.

This issue also includes an up-close look at the new Microsoft Surface Book. I've been complaining for years that there are no truly well-designed, high-end Windows laptops on the market. MacBooks are beautiful; Windows PCs are functional. That changes with the Surface Book. Microsoft also finally nailed the hybrid concept, thanks in large part to Windows 10. Be sure to check out Joel Santo Domingo's full review.

Finally, thanks to everyone who's used the #ilovepcmag hashtag on Twitter. Keep it up, and I'll keep sending out links for our secret sale: six issues for \$1. Just don't tell my circ department.

A handwritten signature in black ink, appearing to read 'Dan Costa', with a stylized flourish at the end.

dan_costa@pcmag.com



Free to Be... TV and Me

I read Evan Dashevsky's article on streaming TV shows, paywalls, and corporate cable monopolies ["Fox News to Cord Cutters: Drop Dead," September 2015] and found it quite interesting.

We as consumers should be able to get our point across that we don't necessarily want to constantly be paying through the nose for everything. A number of years ago, even here in overtaxed Canada I was able to view a lot more TV content by streaming than I can now. Not only are there the restrictions about viewing across international borders, now we are only able to watch a few shows unless we have satellite or cable service.

Yes, I am old enough to remember adjusting the rabbit ears on the TV to be able to get a better picture. Plus, I was the remote: Dad would tell me to get up and change the channel or adjust the volume. How things have changed. But at that time we had free TV. Advertisers paid, in essence, for the shows to be broadcast, and we had to watch the commercials.

I believe the solution has to come from the people who are paying the bills, the advertisers. When I pay my cable bill, I pay for the variety of channels I get, plus the service to bring it to my home. I also have a PVR that allows me to record shows... I can watch them, not only at my convenience later, but [skipping] commercials.

If I want to watch a show by streaming it on the Internet, I am absolutely locked in to watching the commercials. I believe if advertisers started pushing the networks (whose sites I am viewing the shows on) to free up the viewing of the shows online to people without a cable/satellite subscription, viewers would actually see their ads and might get better bang for their buck, and we viewers could watch free TV again.

—Greg Powell

OUR RESPONSE:

I totally agree with you, Geoff. The TV networks need to extract themselves from the ISPs' totalitarian regime—and they need to do it fast. Streaming video content won't be a mere supplement to cable; it'll be a wholesale replacement. The idea of a buffet-style cable provider that limits your choices based on your ZIP code is a complete anachronism in 2015.

The networks are—with some justification—anxious about making a transition to digital (see today's shell of a music industry), but if they fail to adapt to this change they'll find themselves floundering in the technological wake (see print media).

I'm actually surprised that advertisers haven't insisted that cable networks make their content available to stream online to those without a cable subscription (though part of this may be due to legacy contracts with the ISPs). The advertisers want to get their commercials out in front of as many eyeballs as possible, and the TV networks are surely more than willing to allow them to pay for it.

There's no reason to believe that video content won't continue to be ad-supported. Viewers have demonstrated their willingness to work with this model—even if the content is behind a subscription paywall (see Hulu, not to mention ad-supported content on basic cable long before that). The ISPs are the ones holding up this long overdue transition.

—Evan Dashevsky, Features Editor

Ask us a question!

Have a question about a story in *PC Magazine*, one of the products we cover, or how to better use a tech product you own? Email us at letters@pcmag.com and we'll respond to your question here. Questions may be edited slightly for content and clarity.



What's New Now

**DISNEY-THEMED PROSTHETICS
MAKE YOUNG PATIENTS HEROES**

FAREWELL SILICON?

**HOW CISCO IS TEACHING
CLIENTS TO CHILL**

**VALVE'S MOVIE BRATS: INSIDE THE
SOURCE FILMMAKER COMMUNITY**

TOP GEAR

Disney-Themed Prosthetics Make Young Patients Heroes

BY STEPHANIE MLOT



A WHOLE NEW WORLD

Open Bionics is giving children in need of prosthetics the opportunity to get them—and play Iron Man, Elsa from *Frozen*, and more.

Firefighter, police officer, astronaut, superhero: Kids dream big when it comes to the future. But saving the world may not be so far-fetched, thanks to Open Bionics.

The Bristol, England–based company is 3D printing robotic arms for children to let them embody some of their favorite characters.

A 2015 Disney Accelerator participant, Open Bionics hopes to begin selling its designs next year for less than \$500.

The start-up's first three models are Iron Man's red gauntlet, the sparkling glove of Queen Elsa (from *Frozen*), and a lightsaber hand inspired by *Star Wars*—with more to come.

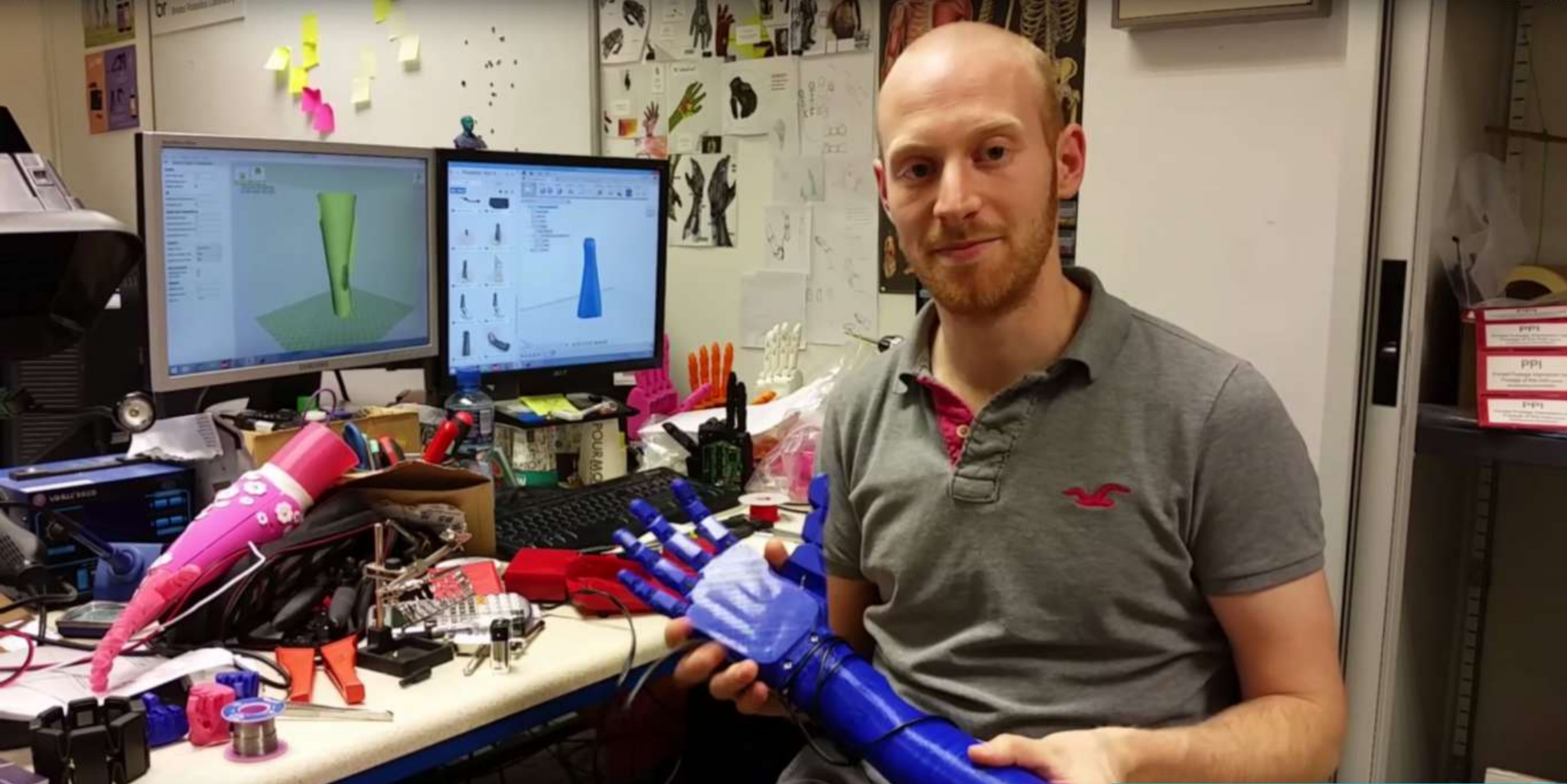

“Now kids can get excited about their prosthetics,” the company website reads. “They won’t have to do boring physical therapy, they’ll train to become heroes. They’re not just getting medical devices, they’re getting bionic hands inspired by their favorite characters.”

Awarded \$120,000 in capital and given access to Disney designers and technicians, Open Bionics built its three prototypes during a 90-day Disney Accelerator program in Los Angeles.

Open Bionics aims to provide kids (and amputees of any age) with more eye-catching, inspiring prosthetics. But the hands—controlled by bioelectric sensors attached to the user’s muscles—are not toys. The devices provide young amputees and children born without hands a sophisticated level of functionality. It also monitors muscle development, and comes with fun features.

The Iron Man prosthetic, for instance, has a vibration motor that shudders when the user “fires” a rocket from their hand. Prosthetic fingers crossed for a web-slinging Spider-Man arm coming soon.

Disney also owns ESPN and Pixar—just imagine what you could do with a laser-shooting Buzz Lightyear arm.

OPEN HEARTED

Open Bionics founder Joel Gibbard shows off the work his company is doing providing entertaining prosthetics for children who desperately need them.

Farewell Silicon?

BY STEPHANIE MLOT

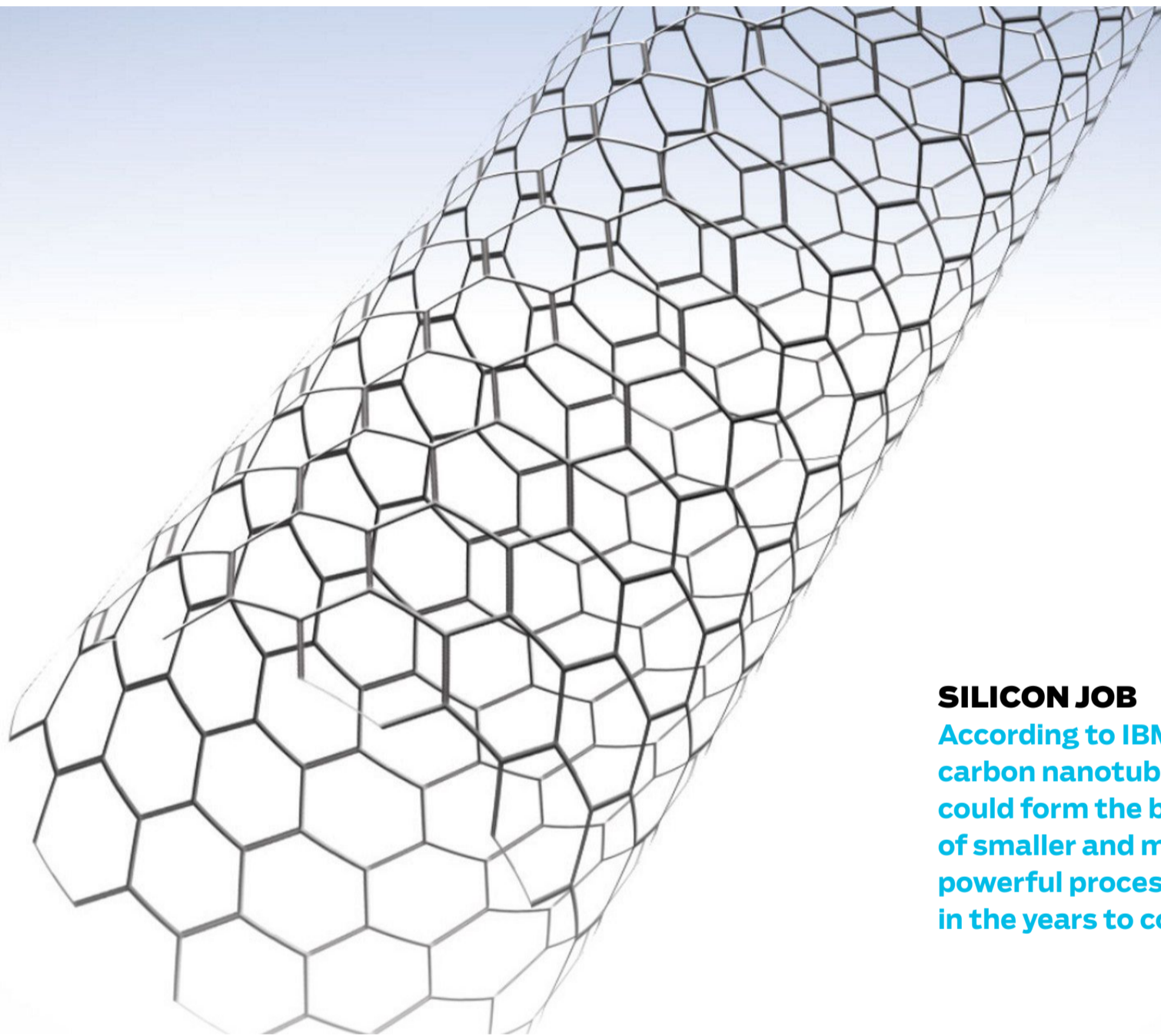

Image courtesy of IBM Research

SILICON JOB

According to IBM, carbon nanotubes could form the basis of smaller and more powerful processors in the years to come.

Carbon Nanotube Valley doesn't have the same ring to it as Silicon Valley, but we might have to live with it if IBM's newest breakthrough has legs.

IBM Research has “demonstrated a new way to shrink transistor contacts without reducing performance of carbon nanotube devices, opening a pathway to dramatically faster, smaller, and more powerful computer chips beyond the capabilities of traditional semiconductors,” the company announced in October.

This, according to IBM's VP of Science and Technology, Dario Gil, was “one of the most daunting challenges facing the chip industry.”

According to IBM, making the switch from silicon to carbon nanotube chips would improve high-performance computers, enable faster analysis of Big Data, increase the power and battery life of mobile devices and the Internet of Things, and allow cloud data centers to run more efficiently and economically.

“As silicon technology nears its physical limits, new materials, devices, and circuit architectures must be ready to deliver the advanced technologies that will be required by the cognitive computing era,” Gil said.

Silicon transistors—the tiny switches that carry information on a chip—have been getting smaller and smaller over the years. But “with Moore’s Law running out of steam, shrinking the size of the transistor—including the channels and contacts—without compromising performance has been a vexing challenge troubling researchers for decades,” IBM said.



Making the switch from silicon to carbon nanotube chips would improve high-performance computers.

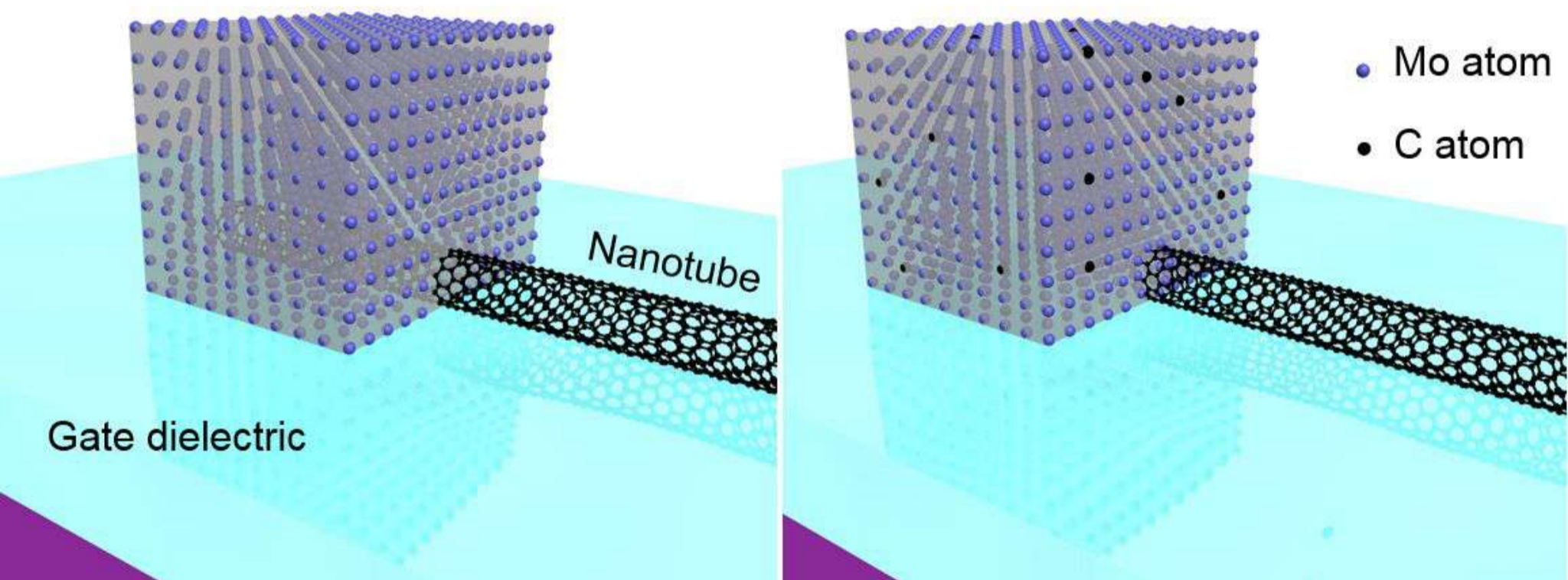

Carbon nanotube transistors, on the other hand, “operate as excellent switches at channel dimensions of less than ten nanometers—the equivalent to 10,000 times thinner than a strand of human hair and less than half the size of today’s leading silicon technology,” IBM said.

As their name suggests, carbon nanotubes are single atomic sheets of carbon rolled into a tube, which form

BOND RATING

These schematics show the conversion from side-bonded (left) to end-bonded (right) contacts to a carbon nanotube.

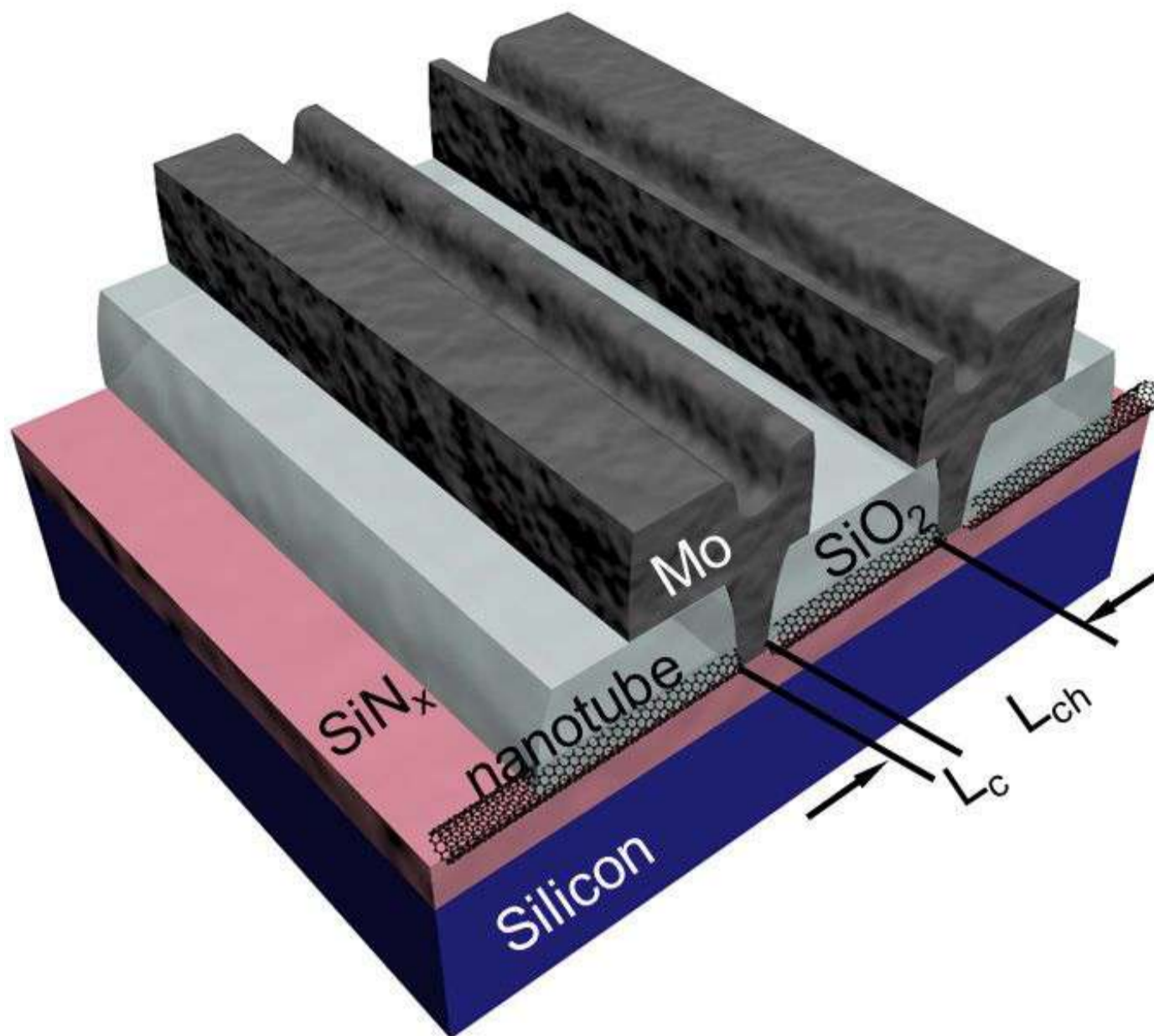

NANOTUBE TRANSISTOR

This schematic shows the fabricated nanotube transistor with an end-bonded contact and a contact length of less than 10nm.

the core of a transistor device. According to IBM, electrons move more easily in carbon transistors than silicon-based devices.

“Inside a chip, contacts are the valves that control the flow of electrons from metal into the channels of a semiconductor,” IBM said. “As transistors shrink in size, electrical resistance increases within the contacts, which impedes performance. Until now, decreasing the size of the contacts on a device caused a commensurate drop in performance—a challenge facing both silicon and carbon nanotube transistor technologies.”

For this demo, researchers ditched traditional contact schemes “and invented a metallurgical process akin to microscopic welding that chemically binds the metal atoms to the carbon atoms at the ends of nanotubes.” The contacts could then shrink below 10nm without a performance drop.

“This breakthrough shows that computer chips made of carbon nanotubes will be able to power systems of the future sooner than the industry expected,” Gil said.

The tech titan this summer also unveiled the first 7nm node silicon test chip—a step toward replacing traditional silicon devices, and part of its \$3 billion chip R&D investment.

How Cisco Is Teaching Clients to CHILL

BY SOPHIA STUART

CHILL PILL

The Cisco Hyperinnovation Living Labs explores creative solutions to new connectivity challenges posed by the Internet of Things.

Everyone knows how difficult it can be to get home peripherals to talk to each other. Now imagine that challenge on a massive scale and you have Cisco's Internet of Things effort—or, as the company calls it, the Internet of Everything (IoE).

PC Magazine went to Silicon Valley recently to check out the Cisco Hyperinnovation Living Labs (CHILL) and learn how the company is preparing for the next wave of connectivity.

The CHILL lab is in Building 11 of Cisco's rambling campus outside San Jose. It's a mad scientist's playhouse, something that Q of James Bond fame might relish, full of gadgets and drones, telepresence robots, and reusable materials.

One lab table is completely given over to an intricate model, built entirely of Lego, of a shipyard with containers and a train set running around the periphery. Apparently it's a former supply-and-demand project plan in 3D for a Cisco partner. But the level of detail is impressive; there's even a Lego cat crouching behind the dumpsters.

On another wall is a sensor-enabled supermarket shelf setup, complete with drones that were deployed in an experiment to ascertain whether it would be feasible to use them in a dark store overnight to replenish shelves. The far wall is all screens showing live feeds of concurrent data science evaluations.

It looks like a glorious place of experimentation. But it's serious business, said Kate O'Keeffe, managing director of CHILL. "Succeeding in the future world

A DRONE IN THE DARK

This drone at CHILL was designed to determine what items in a store needed to be restocked.

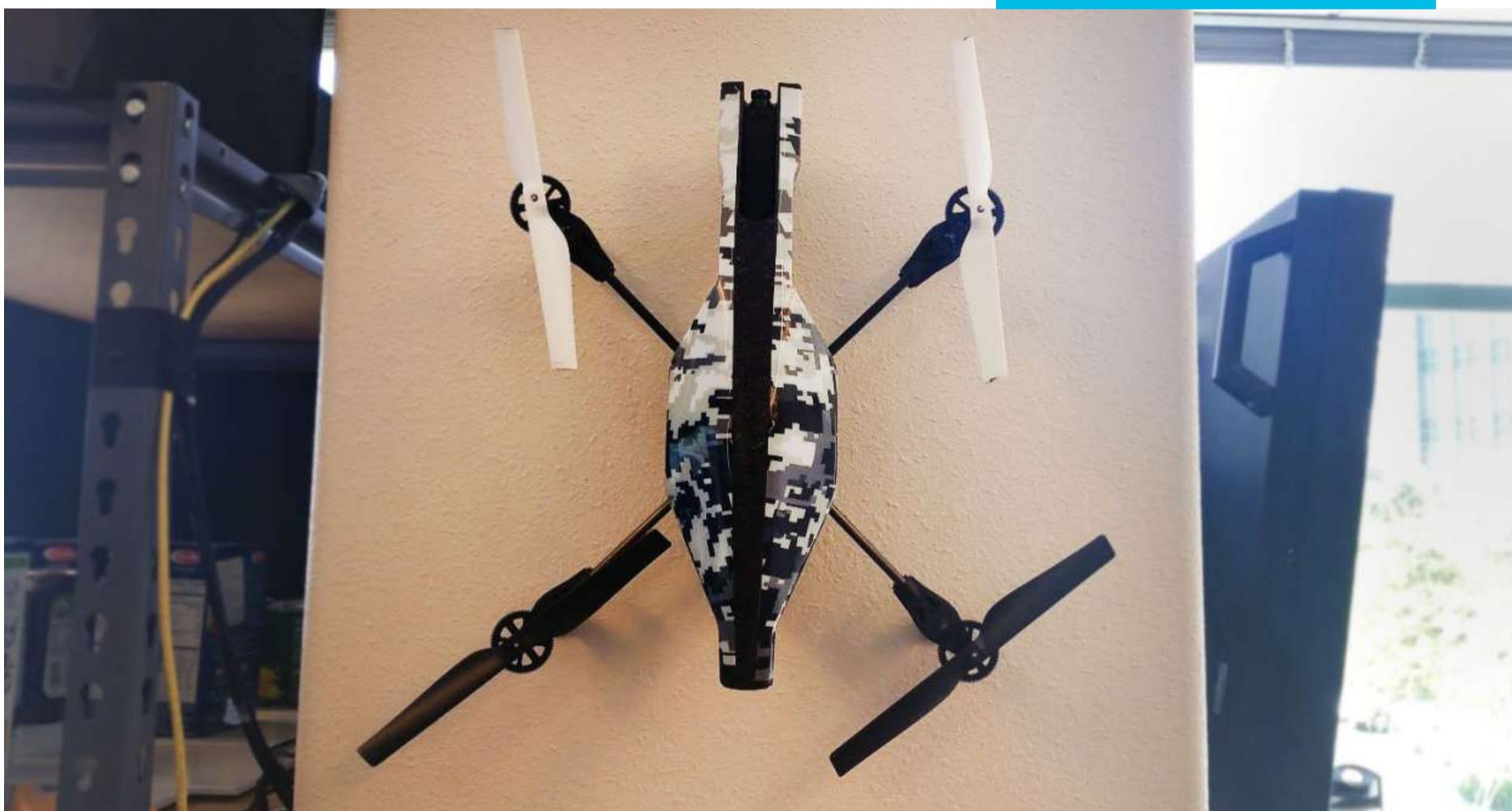

economy is in lighting up the world's dark assets," O'Keeffe said. "Because the net value of the Internet of Everything is \$19 trillion, but that requires the world's corporations playing well together; which they don't always do."



O’Keeffe has been with Cisco for five years and relocated to Silicon Valley from its Singapore office after running a drought solution program for a government-owned water supplier in her native Melbourne, Australia. Her role now is to bring senior Cisco customers into CHILL and out of their comfort zone. They must examine how the IoE is going to disrupt (a polite word for “destroy the existing business model”) their future profits if they don’t wake up.

“It’s a circus,” said O’Keeffe. “Basically there are 80 to 100 people involved at any one time, to drive this rapid innovation and come up with IoE solutions for the future. We include people from companies at every level, from the top execs right down to end users, their customers. Projects that used to take 18 to 24 months must now be built, evaluated, and tested in days. And that is the point of CHILL.”

It’s like *WarGames* for corporate America. Which is where the spy cases come in.

Ben Varghese, an emerging technology consultant at Cisco Consulting Services, motioned us over to the back space of CHILL. Varghese’s role is to advise customers on disruptive business and technology strategy by creating prototypes with robotics, virtual reality, augmented reality, 3D printing, CAD, Wi-Fi, BLE, and RFID. Basically, he gets to build cool things. Or show executives who have spent the last 20 years stuck behind desks how to do so.

“We use the Warp Accelerated Rapid Prototyping (WARP) kit,” Varghese explained. “Our teams of makers, hackers, lawyers, decided that this whole

WARP SPEED

The Warp Accelerated Rapid Prototyping (WARP) kit makes it easy for the CHILL team to build any prototypes or demonstration units they may need, regardless of where on Earth they are.



process of innovation was taking way too long, so we built a kit that has everything from code samples to hardware like Raspberry Pi that allows our team to go to remote sites and build stuff. Yes, this is our spy kit, in essence.”

O’Keeffe and Varghese are about to take the spy kits (in robust carry-on cases, which fit under the seat in front on a plane for swift disembarkation purposes) and fly to Germany. They will be setting up the WARP units in an abandoned factory outside Berlin to prototype ideas with clients such as Caterpillar, DHL, and Airbus, all in the same CHILL space. It’s top secret, so O’Keeffe won’t reveal which IoE problem they’ll be trying to solve, but it sounds like a fun trip.

In a way, Cisco has kept true to its roots. The company started in December 1984 because cofounders Len Bosack and Sandy Lerner, both working for Stanford University, wanted to email each other from their respective offices located in different buildings but were unable to due to technological shortcomings. So they built the first multi-protocol router. Thirty-two years later, Cisco is now teaching the world’s corporations how to connect to each other via the IoE with a few WARP kits, telepresence robots, and other splendid gadgets. And Legos.

INTERNET OF EVERYONE

By bringing together people and ideas from many different companies, Cisco hopes to expand how well it and CHILL meet all people’s needs.

Valve's Movie Brats: Inside the Source Filmmaker Community

BY JORDAN MINOR

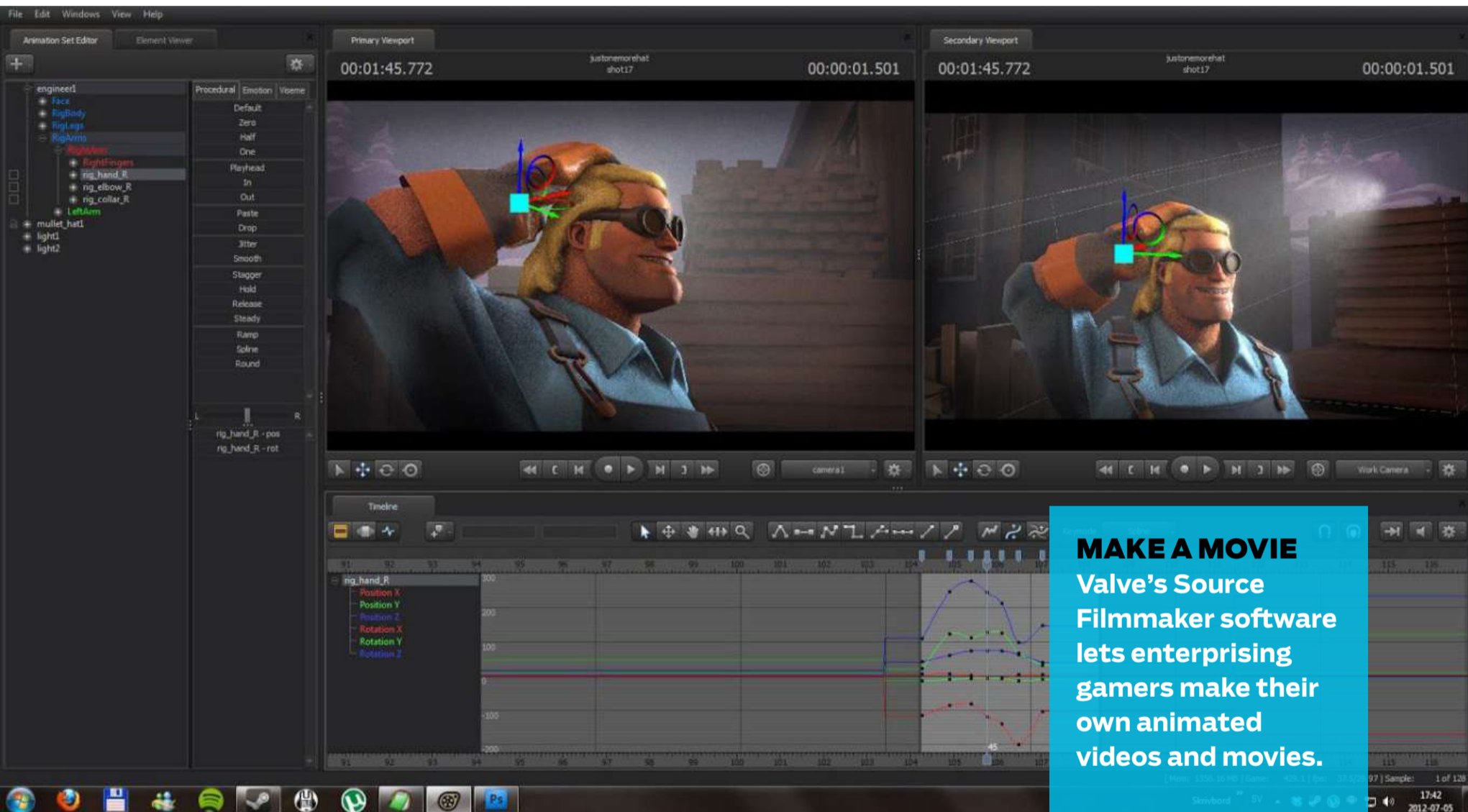

Post-production film artist Adam Palmer sold off all his film equipment to play with a video game program. “I was so confident this was the direction I wanted to go,” said Palmer, who left live-action filmmaking to instead work with gaming company Valve’s 3D animation program Source Filmmaker. “I haven’t looked back since.”

A vibrant community of digital artists has been born thanks to Source Filmmaker. Valve fans, already some of the most passionate PC gamers out there, are using the free yet robust software to create everything from high-quality short films to funny animated sketches to truly bizarre videos akin to those you’ll otherwise find only in the deepest, darkest parts of the Internet. But we are only just beginning to see its full potential. Through Source Filmmaker,

Valve is giving gamers new and exciting ways to express their creativity. And by combining the best of movie editing and game development, the company is changing filmmaking as we know it.

MEET THE TEAM

Source Filmmaker entered open beta on June 27, 2012. But hints of its existence began appearing years earlier. The very first Source Filmmaker video was a trailer for a WWII shooter game called *Day of Defeat: Source*, back in 2005. Valve never officially acknowledged the use of the tool at the time, but intrepid fans, who refer to the program as SFM, eventually stumbled onto the secret.

August “Rantis” Loolam was one of the first staff members of Open Source Filmmaker, a Steam group of active users of the program. “I first learned about SFM sometime in 2009,” he said. “I had discovered some documentation of an SFM version from 2007 on the official Valve developer wiki. After further research, I learned Valve planned to release this tool.”

Valve’s *Meet the Team*, a collection of comedic short animated films showcasing the different classes of its popular shooter *Team Fortress 2*, also started in 2007. Although we didn’t know it at the time, Valve was using these videos to further test its new form of filmmaking. When “Meet the Pyro,” the last video in the series, was finally released, it came with the surprise announcement and launch of the PC-only Source Filmmaker program.

“Most tools only create a fraction of a movie: a renderer, a 2D video clip editor, a keyframer, a motion capture editor, a sound editor,” Valve explains on the SFM website. “The SFM is a hybrid of all these workflows merged into a single system, where you can create an entire movie by reusing assets and events from the video game world.”



In other words, Source Filmmaker is a game engine that lets filmmakers and hobbyists craft virtual sets and props and manipulate them in real time. The animators therefore have precise and immediate control over their recordings. With other animation tools, it can take hours to complete single aspects of clips, but Source Filmmaker users can make changes in minutes with controls any video game player can understand. Granted, the Source engine's technical limitations might hamper more ambitious projects, and using elements from non-Source games can be tricky for more casual users. But with Source Filmmaker, what you see is what you get, and that low barrier to entry makes it possible for artistic freedom to flourish.

Besides its all-in-one approach, Source Filmmaker's basic mechanics aren't too different from the ones machinima creators have been using for years to make movies out of games. Halo, The Sims, and even Valve's own Garry's Mod already have bustling filmmaking subcultures, so this isn't a particularly new movement. Think of it this way: Digital distribution existed before Valve's Steam store, but Steam now leads the market when it comes to downloading games online. Source Filmmaker is just the Steam of machinima.

THE RED CARPET

To celebrate the best of what the Source Filmmaker community has to offer, Valve holds an annual awards show for creators and their films, called the Saxxy Awards. (The name comes from the Team Fortress 2 character Saxton Hale, who's also the trophy's model.)

"The Saxxy Awards definitely help shine a spotlight on the software for the entire gaming community and promote people to use it," says Loolam, who was also part of the team behind *Lil' Guardian Pyro*, the overall winner of the 2013 Saxxy Awards. "I remember many individuals coming forward to me and the rest of the team saying they were inspired by us to learn how to animate."



Source Filmmaker users can make changes in minutes with controls any video game player can understand.



SAXXY APPEAL

The Saxxy Awards, named for a character in Team Fortress 2, are how Valve recognizes the best of the projects the Source Filmmaker community is able to create.

PYRO TECHNIC
Lil' Guardian Pyro
was the overall
winner at the 2013
Saxxy Awards.



With categories including Best Action Film, Best Drama, and Best Short, the awards also demonstrate how versatile Source Filmmaker can be.

“I think that SFM can work with any genre,” said Fine Leather Jackets, the creator of *Disruption*, which won in 2013 for Best Comedy. “Sometimes I’ll just mash up things in silly ways, like with the video *The Doom*. It’s the result of combining Tommy Wiseau’s infamous film *The Room* with the Doom universe.”

Meanwhile, one of the most anticipated SFM projects is a drama, *End of Line*, by BioWare cinematic artist James McVinnie. Such diversity in styles proves Fine Leather Jackets’ point that “it all depends on what the creator wants to do.”

Saxxy Award winners are the poster children of Source Filmmaker, but rest assured that the community has radical, experimental, and independent filmmakers, too.

One of the craziest and funniest underground Source Filmmaker movements is the Shrek Filmmaker scene. When asked to sum up these videos in one word, animator James “Pr1ncessShrek” Tavernor responded, “Glorious.”

Based largely on 4chan and Weird YouTube’s semi-ironic worship of DreamWorks Animation’s famous green ogre, and the fact that the “S” in SFM could also stand for “Shrek,” these videos typically place Shrek in glitch-filled worlds of horrifying imagery and Smash Mouth references. *Shrek It Ralph* and Tavernor’s own *Shreking Ball* (a parody of the Miley Cyrus song “Wrecking Ball”) are pretty self-explanatory. But also consider *Shrek Gets Spooked*, the more esoteric *Goosebumps* crossover with nearly two million views.

Plenty of Source Filmmaker videos are equally surreal non-sequiturs. But there’s something about the baffling shared subject matter of these works, like their frequent use of the phrases “Shrek is dreck” and “Shrek is love, Shrek is

life,” that makes them truly noteworthy. Tavernor agrees, “All the Shrek SFM films are comedy gold.”

The cult is only growing. “I noticed Shrek stuff appearing on other SFM YouTube channels and the creator of the model had the download link right on his video. In my never-ending quest to grab more SFM models, I downloaded it,” says Source/Shrek Filmmaker Marissa “GamerChick5567” Blenz. “I don’t think Shrek SFM videos will die for a long time because they are just so wacky, and people love silly stuff.”

The Shrek Source Filmmaker scene also illustrates just how easy it is for animators to breathe life into their imaginations and give them an audience, no matter how screwed up or award winning they may be. And with tens of thousands of Source engine assets, from Shrek’s swamp to Titanfall’s giant robots, just waiting for their spot in the SFM limelight, who knows what the next off-kilter Source Filmmaking movement will be?

NEW HOLLYWOOD

For SFM users like Palmer, goofy side projects became stepping stones to larger, more professional prizes. “I got the opportunity to make a 25-minute sci-fi film for Oracle using SFM,” says Palmer. “So I decided to start my own company.”

Working with a team of fellow users, Palmer turned filmmaking into an actual business by integrating it with the rest of his film editing software. “We’ve been able to outbid people by a large degree because it’s so much cheaper to make films using SFM.” Among Palmer’s clients is the Monochrome LLC, the developer behind indie horror game Contagion.

As Source Filmmaker continues to thrive, Valve remains conspicuously silent. Source Filmmaker is dense and powerful software, clocking in at more than 12GB. It’s so big and complex that new users have a hard time wrapping their heads around it without guidance. I know, I tried.



WHEN WORDS FAIL

The cranky green ogre Shrek has become a star of a subgenre of Source Filmmaker videos that finds him enmeshed in myriad surreal or hilarious situations.



“Valve is interesting in the sense that they’ll release this incredible program, and then they won’t tell you how to use it,” Palmer said to me. “They’re very hands-off.”

When building his business, Palmer reached out to Valve in the hopes of forming a professional relationship, or at least getting some more official documentation, but the company wasn’t interested. Appropriately enough, no one at Valve responded to any of my attempts to interview someone at the company for this story. As Palmer put it, “Is anyone there? Are they listening? Do they care?”

This is not to say that the folks at Valve are entirely absent. “They added DLC and Steam Workshop support to SFM so you can upload your own models, particles, and maps,” said Sinane Helve, a moderator on the SFM subreddit. “Even if it’s small, everyone around the world can reach the stuff you have done and use your creations in their movies.”

Valve also provides a series of lengthy and comprehensive video tutorials explaining how Source Filmmaker works and what makes it special. The narrator is Bay Raitt, a now-former Valve employee whose animation expertise helped bring Gollum’s face to life in Peter Jackson’s *Lord of the Rings* trilogy.

But where Valve stops, the Source Filmmaker community has done an excellent job of picking up the slack. Zachariah Scott, for example, cofounded the Open Source Filmmaker Steam group.

“We give SFM community members a place to meet, cooperate, and socialize in such a way that they can solve each other’s problems and teach each other,”

Scott said. “We give SFM community members a kick in the pants to motivate them to be less closed off.”

Without the support of the community, Palmer said his corporate ventures would have never succeeded.

So where does Source Filmmaker go from here? Palmer believes it could usher in a whole new era of intuitive, game-powered filmmaking. “If you look at the professional visual effects industry, they are also moving toward real-time stuff,” Palmer said, citing films like *Avatar* and companies like Nvidia. “It gives more power to the artists, and that’s always good.”

But the Source engine itself isn’t getting any younger, and fierce new competition looms. Unreal Engine 4 and CryEngine 3 are supposedly introducing similar cinematic abilities, but with the added graphical improvements of their new technology.

“I’m still not sure if I’m going to switch,” Palmer said, fearing Source Filmmaker may get left behind in the animation arms race it inadvertently started. “If Valve makes a Source 2 engine, I think SFM has a real future. If they don’t, it may just become a hobby.”

Fortunately, the company has confirmed it will release Source 2, a next-generation engine that will be free for developers to use. A modified version of Source Filmmaker with Source 2 engine integration arrived alongside a recent update to Valve’s wildly popular multiplayer online battle arena, Dota 2. And considering Valve’s upcoming VR plans, SFM’s future possibilities are even more tantalizing. Imagine wearing a headset to enter a world and narrative you created yourself.

For Palmer and the rest of the Source Filmmaker community, filmmaking is as much about the journey as the finished product, and the software makes creating movies like playing a video game. It’s an enjoyable experience unto itself, and that won’t change. “SFM is so much fun that I think I’ll always be using it no matter what,” Palmer said. “It satisfies my creative soul.”



**Imagine
wearing a
headset to
enter a world
and narrative
you created
yourself.**

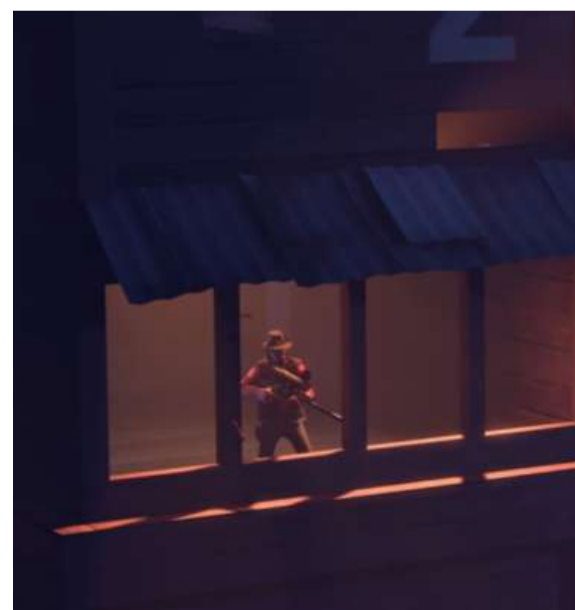

What We Love Most This Month

BY STEPHANIE MLOT

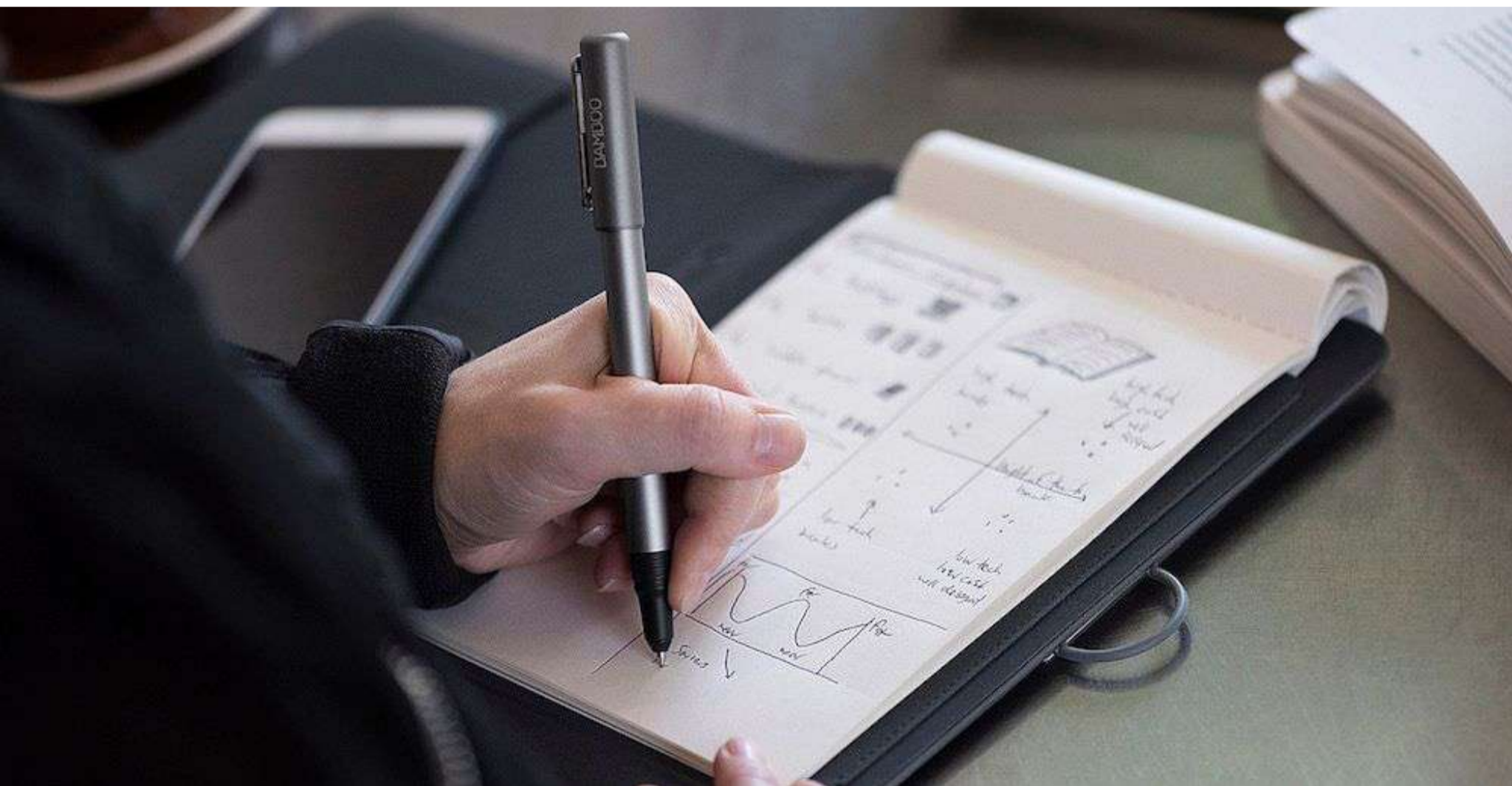

BAMBOO SPARK

Wacom is bringing longhand back into fashion with the Bamboo Spark smart folio. The Spark pen—compatible with most 5-by-8-inch paper—combines traditional ink with electromagnetic resonance technology to convert your strokes into digital content. Pair your iOS or Android device with the pen, then push a button on the folio to save up to 100 pages of work, even in offline mode. Wacom offers three models: with room for a smartphone, a tablet, or the iPad Air 2.

\$159.95 wacom.com



What We Love Most This Month

BY STEPHANIE MLOT



DOCK FOR APPLE WATCH

The Apple Watch brings style and sophistication to your wrist, so why not return the favor with the Native Union Dock? The minimalist device makes it easy to slip on your wearable for safe keeping while it recharges. Designed to fit all Apple Watch models, sizes, and straps, the Dock magnetically holds the gadget in place, and rotates for the best viewing angle. Each night, flip the Dock onto its side to transform your Watch into a bedside alarm clock.

[\\$59.99](#) nativeunion.com



What We Love Most This Month

BY STEPHANIE MLOT



OCO

Pull that surveillance camera out of your kid's teddy bear and pick up a more sophisticated home-monitoring device. The Oco is a simple camera that lets you keep a digital eye on your home, business, baby, and pets, whether you're in the other room or on vacation. Use the iOS- and Android-compatible apps to livestream your kitchen, get sound and motion notifications, and watch 10-second clips from the day. Plus, two-way talk lets you interact with family (including your dog).

\$149 getoco.com



What We Love Most This Month

BY STEPHANIE MLOT



SKEYE PICO

If your family (or common sense) won't let you play with full-size drones in the house, pull out the Skeye Pico. Billed as the world's smallest drone (0.87 by 0.87 inch, 0.25 ounce), Pico is gentle enough to sit on your finger, but its six-axis flight control system and auto-adjustable gyro sensitivity let you show off flips, spins, and aerial dives. Just throw the Skeye Pico into the air to launch, then pilot it with the handheld controller. You even get four replacement rotor blades, for when someone accidentally steps on the diminutive drone.

\$49 trndlabs.com



What We Love Most This Month

BY STEPHANIE MLOT



WILSON X

Practice makes perfect, and with the Wilson X connected basketball and mobile app, you'll be shooting swishes in no time. The ball tracks makes and misses for later analysis, and the app entices ballers with four game modes that record shooting percentage and range. Don't worry about recharging the basketball: Wilson X's battery runs for more than 100,000 shots (that's 300 per day for a year!).

\$199.99 wilson.com



Opinions

EVAN DASHEVSKY

ERIC GREVSTAD

TIM BAJARIN

“It will be interesting to see how American consumers react to this new speed bump.”

EVAN DASHEVSKY
NEW CREDIT CARD CHIPS MEAN
INNOVATION, ANNOYANCE

New Credit Card Chips Mean Innovation, Annoyance

Following Europe's lead, the United States is finally transitioning from credit cards based on magnetic strips to those based on embedded chips, known as EMV technology. Perhaps you've received new credit cards with embedded chips recently and didn't know why? Well, there you go.

Aside from the issuance of new cards and point-of-sale (POS) devices, there's a new set of retail rules that should hasten this changeover. Until early October, liability for credit card fraud was placed solely on the issuers' shoulders (don't worry, they weren't hurting), but now the liability will be shifted onto retailers who neglect to use a chip reader on a chip-enabled card.

The experience of other nations has shown that chip technology is indeed far less hackable than magnetic strips. But if EMV is unequivocally more secure than magnets, it is by no means airtight—dedicated thieves have already found their way into the system. Additionally, the chips offer no security for financial data already stored inside a retailer's system, nor do they protect you at all on online purchases. But, despite falling short of complete infallibility, most security experts believe this is a smart move.

As far as consumers are concerned, the new cards function just like traditional credit cards.

Evan Dashevsky, a features editor for *PC Magazine*, has been writing about tech since 2010 for such publications as *PC World*, *TechHive*, *ExtremeTech*, and *Digital Times*.

The only real difference is that instead of sliding them through an elongated reader, you insert them into a narrow slot and wait for them to do their thing. And therein lies an important point that should be included in the conversation: This new, better technology will most certainly add extra time to your check-out experience.

I've recently started using chip transactions, and I can confirm that the credit check-out process now takes slightly longer than it used to. Not a lot longer, by any means—maybe another 7 seconds or so. For most people, this won't be a big deal. But it will be interesting to see how American consumers react to this new speed bump in their daily lives.

Most people have only had one experience with technology: It gets faster and more efficient. This transition to EMV tech will be a rare instance in which a new and supposedly superior technology creates a greater barrier between us and instant-ish gratification. This transition means that you will soon be spending additional time at check-outs, making additional small talk with the cashier, and taking longer to turn your attention to the next thing you need to do.

This ever-so-slight hindrance may affect consumer behavior. Quick example: One of my absolute favorite developments of the past few years has been the way credit cards and retailers have done away with the need to sign receipts for small purchases. This removed, at most, 15 seconds from the transaction. But that one small step toward seamlessness has made me far more willing to pay for things with my credit card. Convenience is the key.

I'm not advocating a rejection of EMV cards. Far from it. But I think this additional time will spur another long overdue transition: mobile

payments. Americans have more options than ever when it comes to putting aside their physical cards and paying for things with their phones: Apple Pay, Android Pay, Samsung Pay, not to mention many retailer-specific payment apps. Aside from offering seamless transactions, smartphone payments are—in many instances—more secure than those made using physical credit cards.

Although mobile payment technology has yet to catch on with the public in a big way (at least in the U.S.), it is the way of the future. Even if you don't use your smartphone for payments yet, chances are you probably already use mobile payments. In a number of places in the country, if you own a car you are likely enrolled with a regional electronic toll collection agency such as E-ZPass or FasTrak. In this case, your ride is your credit card. Could you imagine ever going back to a pay-per-pass system?

If using a physical credit card becomes that much more annoying because of EMV, then we are just hastening the inevitable death of physical credit cards. And that's a good thing. So, rather than being annoyed by the extra time at check-out, we should be thankful for it. It may be the thing that pushes us down a much-needed path.

evan_dashevsky@pcmag.com



Even if you don't use your smartphone for payments yet, chances are you probably already use mobile payments.



Telecommuting: The Antidote to Rush Hour

What city has the worst commute? Legend has it, Amsterdam, where roving gangs of pranksters are said to pick up innocent smart cars and drop them in the canals.

What's the best place to commute? Your house, where your morning routine quickly takes you from bedroom to breakfast table to home office, with hours of productivity gained instead of wasted.

“Wasted” is putting it mildly, as the typical U.S. commute makes canal diving look cheerful. The Texas A&M Transportation Institute (TTI) recently found a unique way of proclaiming the end of the Great Recession of 2008. To put it in four words: “Gridlock is back, baby.”

The U.S. Department of Transportation says that Americans have driven more than 3.1 million miles in the last 12 months. That's a new record, surpassing the peak of 2007—and, according to the TTI and Inrix, a Big Data analytics outfit that specializes in traffic patterns, that means road congestion has returned to pre-recession levels as well.

The two organizations' 2015 Urban Mobility Scorecard reports that, in 2014, travel delays due to traffic wasted 3.1 billion gallons of fuel and kept travelers stuck in their cars for 6.9 billion extra hours—at a cost of \$160 billion. To bring that home (as if you could get home in a



Eric Grevstad is a contributing editor for *PC Magazine* and *ComputerShopper.com* who has also edited and reviewed products for many other technology publications.

timely fashion), that's 42 hours or \$960 per rush hour commuter.

With 82 hours of delay per commuter, the most traffic-snarled city in the country is Washington, D.C. Runners-up are Los Angeles (80 hours), San Francisco (78 hours), New York (74 hours), and San Jose (67 hours). Drivers on America's ten worst roads (six of which are in Los Angeles, two of which are in New York, and two of which are in Chicago) waste on average three and a half days per year in bumper-to-bumper traffic.

This is not just a problem for big cities. Although the average travel delay per commuter nationwide is more than twice what it was in 1982, it's four times worse than it was in 1982 for cities of fewer than half a million residents.

HOME CURES

Clearly, there has to be a better way—and the home office is it. In fact, it's the best way. Statistics on telecommuting are all over the place because they often conflate those two groups: self-employed operators of home-based businesses and employees of larger firms that have embraced telework. For instance, the U.S. Department of Labor, Bureau of Labor Statistics, says that, as of May 2012, some 29.1 million U.S. workers (or 20.4 percent of the total employed) responded that their typical commute was zero (or answered "yes" when asked if they do any work at home).

But I like the numbers found by GlobalWorkplaceAnalytics.com: In 2005, 34 percent of companies allowed employees to work remotely. By 2013, that figure had climbed to 63 percent, while employee (as opposed to self-employed) telecommuting grew nearly 80

percent. And a recent Lenovo survey of some 6,000 companies adds that 53 percent of employees work from home at least some of the time.

Technically, you qualify for that 53 percent if you pull out your smartphone and check your work email for five minutes on an occasional Saturday. (My old boss at *Home Office Computing* would have categorized you as a WAHAH, for Work At Home After Hours, but the acronym didn't catch on—as opposed to, say, SOHO for Small Office/Home Office—although my chief recollection of that one involves endless vigilance against gags like, “On the Internet, no one knows you're a HO.”)

True telecommuters, of course, log more than the rare evening or weekend stint. They have a dedicated home office workspace instead of the dining room table and use dedicated tools instead of a shared family PC. Most important, they have a support tripod, with three entities or constituencies having their back.

The first is a manager who really “gets” telecommuting, who trusts remote workers to do their jobs instead of fretting that they're watching *Judge Judy* or *Ellen*. They have a manager who doesn't need to be reassured by pings on the quarter-hour like Big Ben, but to whom they are promptly available when questions arise.

The second is a telework-savvy HR department, with policies in place for determining whether telecommuting is a good fit for both the needs of the job and the temperament of the individual. It's also important to have the right kind of education and training available, for manager and telecommuter alike. Ideally, there's enough infrastructure in place to help employees learn how to manage their careers and handle

challenges such as performance reviews (which invariably have a section for “Works and plays well with others”).

The third leg of the support tripod is IT, which needs to do more than just issue a laptop and a password. IT needs to work with telecommuters, managers, and HR to understand the productivity, security, and mobility needs of remote staff. With everything from voice to virtualization to videoconferencing on the menu, a typical home Internet connection may not cut it.

Finally, all parties concerned need to understand the practical limits of telecommuting. Although I’m a big believer in remote work, I’ve learned not to deny the “out of sight, out of mind” phenomenon, whether it’s pinging for pinging’s sake (“Hey, have you seen the employer ROI and employee telework savings calculators at GlobalWorkplaceAnalytics.com?”) or physically coming into the office once or twice a week. The danger of doing your job well is being taken for granted, which can be bad for your future advancement prospects.

How Mobile OSes Could Drive the Future of Personal Computing

There are now almost three billion computers running mobile OSes and up to 1.5 billion devices running desktop OSes. If you focus on the desktop, we believe about 800 to 900 million are personal gadgets, with the rest being used in businesses. But the market for desktop operating systems is contracting. Notably, however, a healthy percentage of those 800 to 900 million consumer PCs are not used every day.

But smartphones are a different story. More time is spent globally per day computing on mobile operating systems than desktop varieties, and this divide is only getting wider.

This is why I think Google introduced the Pixel C hybrid laptop. Like Apple's iPad and iPad Pro, the Pixel C is a recognition that the market for desktop operating systems is much smaller than the market for mobile OSes. Google and Apple have concluded that mobile OSes can play roles in computing beyond 4- to 6-inch screens. I believe they're right.

Nearly 1.3 billion people use a smartphone as their only computer, and many of them are Android-based. If they ever want a more powerful device, are they going to buy a Windows PC? Will they learn a completely foreign OS that does not run all of their apps?



Tim Bjarin is the president of Creative Strategies and a consultant, analyst, and futurist covering personal computers and consumer technology.

My gut tells me that those who first embraced the Internet via Android or iOS will want to stick with these mobile OSes.

The software angle here is notable, too. The software that gets consumers excited, makes developers money, and marches computing forward is all on mobile. So are those developers all of a sudden going to start paying attention to desktop operating systems? I think Google and Apple are betting they will not.

You might be tempted to argue that you can't do real work on a mobile device, but that suggests a limited view of what work entails. Microsoft has acknowledged with its Office apps that even spreadsheets and word processing can and should be done on mobile devices, and Slack and Quip are two prime examples of work getting done on less powerful devices. Like it or not, the world now skews mobile.

But running a mobile OS on a two-in-one or laptop highlights one of the big problems Microsoft has with Windows: It took a desktop OS and tried to scale it down for use in mobile devices. Windows Mobile did not work, but by the time a redesigned Windows Phone emerged, it was too late to catch up with Android and iOS. Windows RT was a bust, and Microsoft's Surface lineup now runs full versions of Windows.

The scaling up of mobile operating systems will be highly disruptive to the traditional PC market. Although desktop operating systems will not go away, they will be moved to the upper end of the productivity curve while iOS and Android dominate the market for consumer and maybe even enterprise devices in the not-too-distant future. Expect the PC world to look very different in in the next three to five years.

Reviews

CONSUMER ELECTRONICS

Google Chromecast

Amazon Fire HD (8GB)

Apple iPhone 6s

HARDWARE

Microsoft Surface Book

Microsoft Surface Pro 4

Acer Chromebase DC221HQ bwmicz

**D-Link AC1900 Wi-Fi USB 3.0 Adapter
(DWA-192)**

SOFTWARE & APPS

Microsoft Office 2016

Bitdefender Internet Security 2016

**Google
Chromecast**

\$35



Google's \$35 Video Streamer Is Better Than Ever



Google wowed us with the Chromecast when it launched two years ago. At the time, the idea of a \$35 device you could plug into your HDTV to watch streaming media was remarkable. It no longer seems as novel, with other inexpensive solutions on the market, but the Chromecast remains a top-notch media streamer. And now the Chromecast has gotten a refresh. The new device is slightly different in design, and a bit faster in operation, but it keeps the same \$35 price tag and mobile device control that made the original so popular. Don't rush out to buy one if you already own the original Chromecast, but as a new iteration it's every bit as strong an option.

NEW DESIGN

The Chromecast is a small plastic puck with a glossy, colorful front side (it's available in black, pink, and yellow) and a matte gray bottom. A short, flat cable comes out of one end and terminates in an HDMI connector. A micro USB port sits opposite the cable, flanked by a small Reset button and an indicator light. The matte side of the device is magnetized, letting the HDMI connector stick to it when not in use. Like the colorful glossy shell, neither of these features will really matter once the Chromecast is set up behind your HDTV.

SETUP

Getting started with the Chromecast is incredibly fast and easy. Plug it into a free HDMI port on your HDTV, plug the power cable into the Chromecast and the wall, and switch to the correct input. Run the Chromecast app on your Android or iOS device, follow a few prompts, enter your network and password, and you're ready to start streaming from any compatible app.

GOOGLE CAST

Like the original, the new Chromecast lacks any sort of on-screen interface or remote. Instead, you need to use Google Cast-compatible apps to send content to the device. Any app that supports Google Cast will display a small Chromecast icon, which you can tap to stream video to the Chromecast. Currently, several hundred apps and services on Android and iOS and through Chrome on PCs and Macs can stream content to the device. That selection covers a wide array of apps and services, including most major streaming video providers like Hulu Plus, Netflix, and (of course) YouTube. Amazon Instant Video isn't compatible with Google Cast yet, however.

All of the audio and video media available on Google Play can be streamed through the Chromecast. That covers a huge number of movies, television shows, and songs. But two of the other biggest streaming media stores, iTunes and Amazon, don't work with Google Cast.

Google Chromecast

PROS Inexpensive.
Easy to set up.
Compatible with many apps, services.
Responsive.

CONS No major new features. Requires smartphone, tablet, or PC to control.



Support is dependent on the app, but the Google Cast platform allows for some interesting second-screen tricks. For instance, if you load a Twitch stream on the Chromecast, your tablet becomes the chat window for the channel, so you can comment as you watch.

SLIGHTLY QUICKER

Google claims the new Chromecast is faster than the original. Because the devices are so dependent on network speeds, and direct benchmarking isn't currently possible, we can't confirm this with scientific certainty. But the new Chromecast loaded Netflix, Twitch, and YouTube streams extremely quickly, never taking more than a few seconds to play video.

The new Google Chromecast doesn't offer any significant changes over the original model, so you don't need to run out and replace the Chromecast already plugged into the back of your HDTV. And if you don't want to rely on your smartphone or tablet to control streaming media on your HDTV, you should consider a slightly more expensive media streamer with a dedicated remote and an on-screen interface, like the Roku Streaming Stick or the Amazon Fire TV Stick. They don't offer the versatility of the Google Cast platform, but they're functional as completely standalone devices. But if you're interested in jumping into the Google Cast ecosystem, the new Chromecast seems quicker and sports the same \$35 price tag, making it every bit as compelling and simple a streaming solution as the original.

WILL GREENWALD

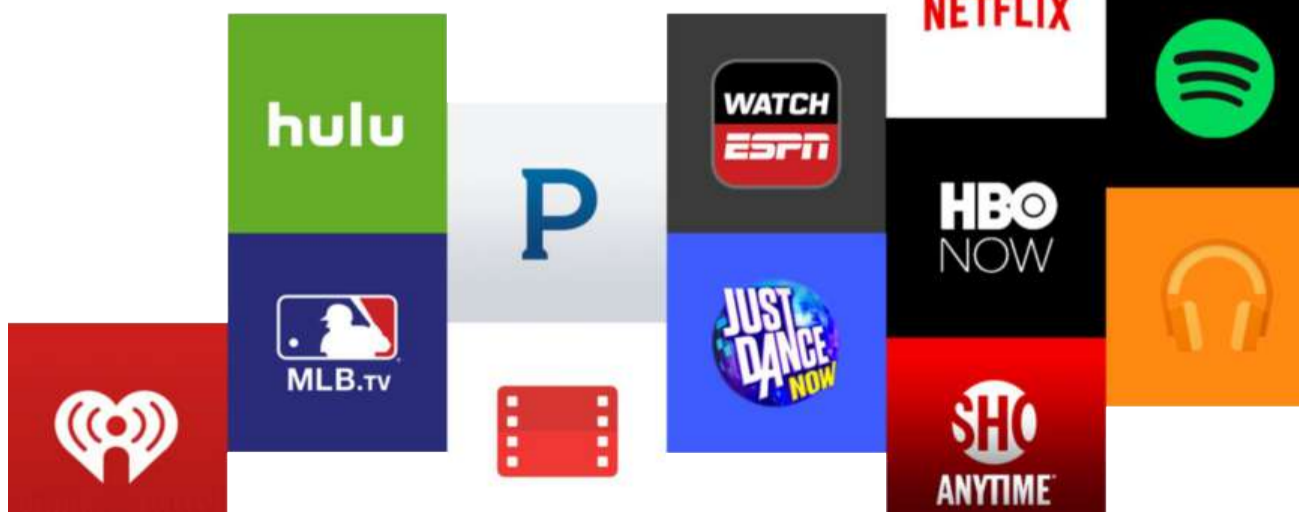

Google Chromecast Audio



EDITORS' CHOICE

The Chromecast Audio (\$35) takes everything that makes the Chromecast so handy, strips away video support, and makes it possible to connect nearly any speaker with a 3.5mm input to your Wi-Fi network for wireless music streaming. Most speaker systems today integrate Bluetooth or some other wireless connection standard, but the Chromecast Audio lets you join them all in the same Google Cast-based ecosystem and avoid juggling Bluetooth pairing for every speaker. It also lets you turn any older speaker (with the right connection or adapters) into a wireless speaker. For this price, that's an incredible deal.

—Will Greenwald

**Amazon Fire HD 8
(8GB)**

\$149.99



Love Amazon Content? This Tablet Will Light Your Fire

The new Amazon Fire HD 8 may not have the same multitasking capabilities as the Samsung Galaxy Tab S2 or the incredible app experience of the Apple iPad mini 4, but for \$149.99, it offers everything you need to fulfill all your basic tablet needs. With access to Amazon's vast content ecosystem, enhanced by a slick new update to Fire OS, the 8-inch Fire HD 8 is a very good tablet for first-time users.

DESIGN AND FEATURES

The Amazon Fire HD 8 looks a bit different than last year's Fire HD 6 and Fire HD 7 tablets. Gone is the simple but distinct angled back panel—now you have a smooth metal finish on the back, available in black, blue, magenta, or tangerine.

Amazon has outfitted the Fire HD 8 with an 8-inch, 1,280-by-800-pixel display at 189ppi. That's not as sharp as the 2,560-by-1,600 display on the Fire HDX 8.9, but the Fire HD 8 costs less than half the price. The display is a little grainy, but good enough to view most content clearly. With its wide 16:10 aspect ratio, the Fire HD is clearly meant for content consumption, whether that's magazines, books, websites, or Netflix.

On the top of the tablet are the Power and Volume Up/Down buttons, the micro USB charging port, and the headphone jack. This is a bit of a strange design choice, as watching Netflix with earbuds while the tablet charges in portrait mode can be a bit of a wire wrestling match. On the left side are two speaker grilles and a microSD card slot that can take cards up to 128GB in capacity. (The Fire HD 8 comes in 8GB and 16GB models, but both give you unlimited free cloud storage for Amazon content.)

Measuring 8.4 by 5 by 0.3 inches (HWD), the Fire HD 8 is a little taller and narrower than both the iPad Mini 4 (8 by 5.3 by 0.24 inches) and the Samsung Galaxy Tab S2 (7.8 by 5.3 by 0.22 inches). Thanks to its size, the Fire HD 8 is easy to hold in portrait orientation despite its somewhat slippery finish.

FIRE OS 5 "BELLINI"

Amazon has heavily revamped the Fire OS software that ships with the Fire HD 8. Fire OS 5 is loosely based on Google's Android 5 Lollipop, but as usual, that's not immediately apparent. Many of the changes are cosmetic, and actually make the tablet look and function more like an Android device. For example, at the bottom of the screen, the Back, Home, and Search buttons have been replaced by Android's now-standard Back, Home, and Open Apps buttons.

At the top are tabs you can swipe through, including Home, Books, Video, Games, Shop, Apps, Music, Audiobooks, and Newsstand. Under each of these is

Amazon Fire HD 8 (8GB)

PROS Affordable. Lots of available content. Unlimited cloud storage for Amazon media. MicroSD card slot.

CONS Unimpressive hardware, form factor. Occasional slowdowns.



your content; on the home screen, you see your most recent downloads, with all of your installed apps under that. As expected, all of Amazon's content-driven apps come preinstalled on the Fire HD 8, including Kindle Books, Amazon Games, Amazon Instant Video, and even Amazon Maps.

Amazon now offers offline content viewing with Prime membership, so you can download and watch movies and shows even when Wi-Fi isn't available. That makes the microSD card slot a welcome addition, especially for long trips.

Unlike the Fire HDX, the Fire HD 8 doesn't give you a Mayday button for starting a video chat with an Amazon representative. Instead you get a slightly watered-down version called Mayday Screen Sharing, where you can call a customer service rep on the phone, and they can access your tablet's screen (with your permission). It's not as quick or as handy, but it still beats most of the competition's methods of just talking to you through the phone.

The Fire HD 8 gives you unfettered access to Amazon's stellar parental controls. With FreeTime you can set up a child's profile on the tablet, and give them access to Disney, Nickelodeon, and *Star Wars* apps and shows. A single child's subscription costs \$2.99 per month. It's really just another way for Amazon to sell you its content, but if you have kids, it's a godsend.

A fair warning: If you stack up Amazon's app ecosystem against the Google Play store, you will be disappointed. You won't be able to access all the latest apps and games available on Google Play, let alone iOS. There isn't even an Instagram app. But once again, this tablet is a content-consumption machine, a way to access Amazon's huge silos of content. Just don't expect a tremendous app experience.





PERFORMANCE

The Fire HD 8 runs on a quad-core 1.5GHz MediaTek chipset, and performs well given its price point. It logged 766 single-core and 1,523 multicore scores on the Geekbench 3 benchmark test, beating some very serviceable tablets like the \$199.99 Asus ZenPad S 8.0 (640 single-core, 1,055 multicore). But the Fire HD 8 pales in comparison with some of the more high-tech (and pricier) tablets out there, like the Samsung Galaxy Tab S2 8.0 (1,225 single-core, 4,309 multicore) or the iPad mini 4 (1,716 single-core, 3,116 multicore).

Games like High Speed Race: Racing Need played smoothly, though things can slow down a bit when multitasking. Opening a book can take a few seconds when you've just quit another application. It can also take a few seconds to quit a movie you're watching. When you flip the tablet into landscape, it takes a full 3 seconds to reorient. But none of this is terribly distracting, and for the most part performance is solid.

The 5-megapixel rear-facing camera takes decent, if slightly grainy, photos. I wouldn't recommend using the HDR setting, though, as you have to hold the tablet still for a few seconds, which is a bit tricky given its size. The 720p front-facing camera is fine for video calls.

In our battery test, which streams video over Wi-Fi at maximum brightness, the Fire HD 8 lasted a solid 5 hours, 44 minutes. That a little more than either the iPad mini 4 (5 hours, 15 minutes) or the Samsung Galaxy Tab S2 (5 hours, 33 minutes).

CONCLUSIONS

The Amazon Fire HD 8 isn't your typical budget tablet. No, it doesn't boast class-leading performance or a high-res screen, but it offers access to content in a small, inexpensive slate, and that might be all you need. Amazon's wealth of television shows, books, magazines, and movies is as much a part of the Fire HD 8's experience as its specs. And if that's what you're looking for, you'll definitely be pleased. If you're more of a power user who wants the latest apps, then go with the iPad mini 4 or, if you need top-notch multitasking capabilities, then the Editors' Choice Samsung Galaxy Tab S2 is for you. And if you're looking to spend even less money, Amazon's new \$50 Fire tablet looks like a good option. We haven't tested it yet, but it too offers access to Amazon's content ecosystem (albeit on lower-end hardware) for a rock-bottom price.

BEN RADDING

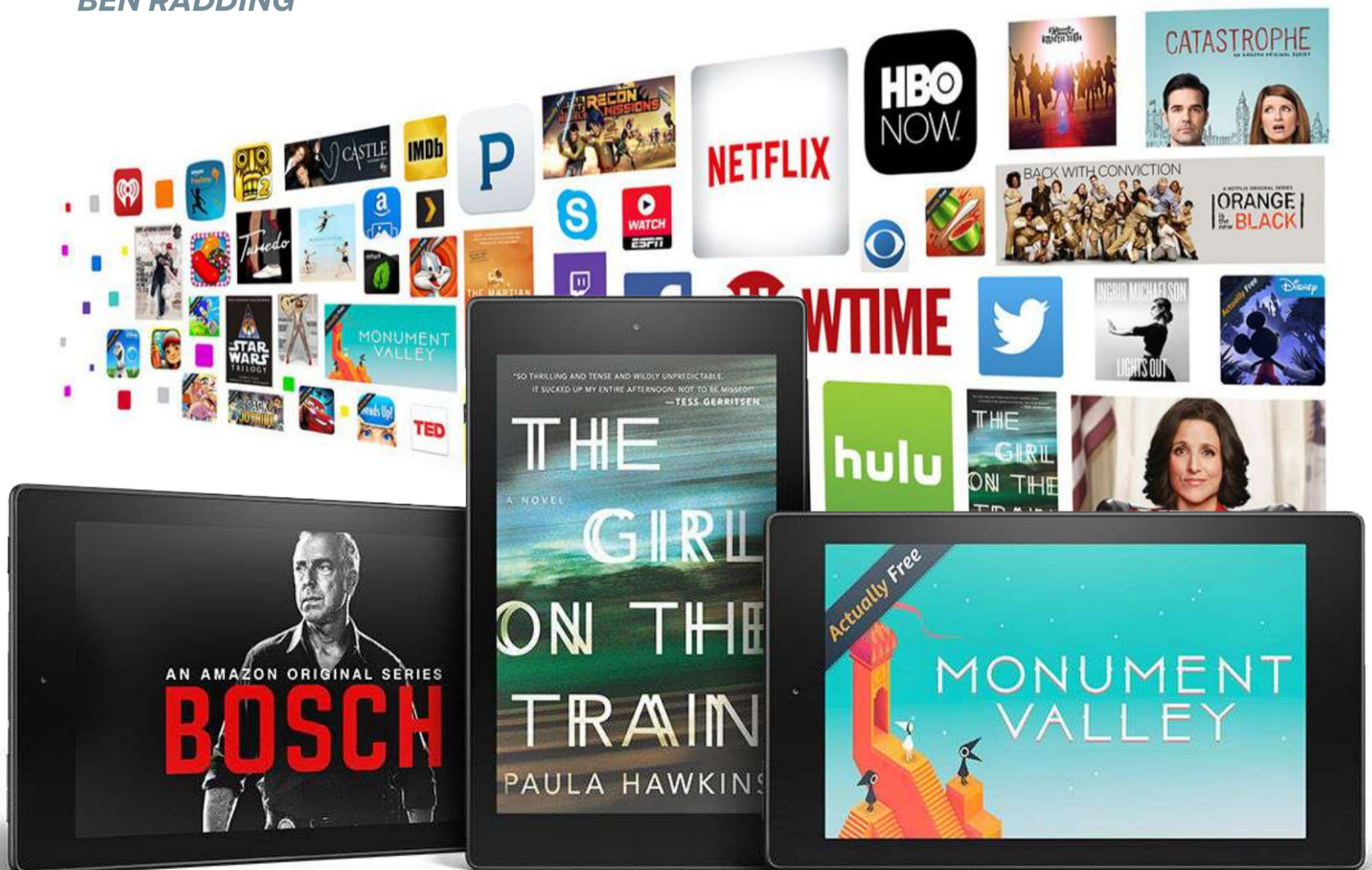

This Year's iPhone Is a Faster, Smarter Upgrade



In Apple's iPhone 6s, the "s" could stand for shutterbug, sensitivity, or even for signal. This year's iPhone is faster (as always). It's also made from stronger materials, though the design is

otherwise unchanged. The more important jumps come in camera quality, signal reception, and the new 3D Touch pressure-sensitive screen, all of which may push existing iPhone 6 owners over the edge to buy the new smartphone.

PHYSICAL DESIGN

The iPhone 6s looks exactly like the iPhone 6. At 5.44 by 2.64 by 0.28 inches (HWD) and 5.04 ounces, it's actually a little bit thicker and a teeny bit heavier than its predecessor (by 0.01 inch and 0.49 ounce), but you really won't notice. (It fit into every soft case we tried, though not all hard or battery cases.)

Just like the iPhone 6, the iPhone 6s has a matte metal back and a glass front with a 4.7-inch, 1,344-by-750-pixel screen. Apple says the display is made from a new Corning glass formulation that's tougher than last year's. Below the screen is the home button, which is also the Touch ID fingerprint sensor. On the back, the camera lens is now slightly larger, and there's an "s" under the word "iPhone" so you don't mix it up with the 6.

Along with the existing black, gold, and silver models, there's a new color, Rose Gold. It's a nice metallic pale pink.

Apple iPhone 6s

\$649 (16GB),
\$749 (64GB),
\$849 (128GB)



WIRELESS AND BATTERY LIFE

Apple has kicked wireless reception up a notch, upgrading from last year's Qualcomm 9x25 modem to the newer 9x35. In Qualcomm parlance, that moves Apple from an X5 modem to an X7. In our tests, that made for better Wi-Fi performance, and support for Category 6 LTE and new frequency bands promise better speeds on AT&T, Sprint, and T-Mobile.

As before, the iPhone 6s supports more frequency bands than any other phone on the market today, and all models except Sprint's are unlocked by default if purchased at full price directly from Apple. That makes the iPhone 6s the ideal phone for global roaming.

There are two models of the 6s, differentiated only by support for AT&T's new Band 30. Sprint, T-Mobile, and Verizon sell the A1687 model, which lacks band 30. AT&T is the only carrier on Earth to use that band, so unless you're planning on switching to AT&T, it shouldn't make a difference to you.

Call quality is solid. The earpiece is loud and noise cancellation is pleasantly aggressive. Interestingly, the main speaker on the bottom is 1-2dB quieter than on the iPhone 6, and the earpiece is 1-2dB louder. Neither change will affect your conversations that much.

Wi-Fi performance has improved dramatically over the iPhone 6, and now matches that of Samsung's Galaxy S6 and Galaxy Note 5. Close to a router with a 100Mbps Verizon FiOS connection, I got up to 40 percent better speed with the iPhone 6s than with the iPhone 6. With a weak Wi-Fi signal, I got 5Mbps down on the iPhone 6s as opposed to 1Mbps on the iPhone 6.

The iPhone 6s has a slightly smaller battery than the iPhone 6, and it showed ever-so-slightly less battery life on our brutal LTE streaming test: 4 hours, 21 minutes, as compared with 4 hours, 33 minutes, on the iPhone 6. In typical use, the two phones had just about the same lifetime on a single charge in my test period.

Apple iPhone 6s

PROS Better LTE reception than the iPhone 6. Excellent cameras. Super-fast processor. 3D Touch has lots of potential.

CONS Front-facing camera could be sharper. Average battery life.



PERFORMANCE AND 3D TOUCH

The iPhone 6s is much more powerful than the iPhone 6. In our benchmarks, the 1.8GHz A9 processor in the 6s was about 40 percent faster than the 1.4GHz A8 processor in the 6. It has better graphics performance than any other phone. It's also faster than any other processor on the market, at least in terms of single-core performance, which is most relevant for mobile operating systems that don't multitask very well.

In real life I saw smoother performance in games like Land Sliders, MiniMotorWRT, and Need for Speed: Most Wanted, but there's an issue of confirmation bias there. The benchmarks certainly show better frame rates. Brand-new iPhones always feel fast, so I'll have to fall back on the benchmarks. The phone gets a bit warm when playing games, which seems to be the case with most new phones we've tested lately, but it's not a deal-breaking problem.

Application launch times haven't changed much, but if you're doing anything involving video editing or image manipulation, you'll find the new phone up to 60 percent faster.

Apple says the phone's new Touch ID sensor is twice as fast as the old one, which was already pretty fast. In side-by-side testing against an iPhone 6, I found that to be true, but we're talking tenths of a second here, so you might not notice.

On the other hand, 3D Touch is one of those innovations that sneaks up on you and then you want to use everywhere. Apple isn't the first device-maker with a pressure-sensitive screen, but it's the first with Peek and Pop, which basically lets you preview content by lightly pushing on the screen. It's ideal for peeking into links, news articles, and previewing emails. Quick Actions, which let you jump to frequently used features within apps from the home screen, are more superficially visible, but it turns out peeking really gets baked into your usage pattern after a few days. And I'm

USE THE FORCE

The iPhone 6s' 3D Touch feature gives you lots of new ways to interact with the phone that make many basic tasks quicker and easier.

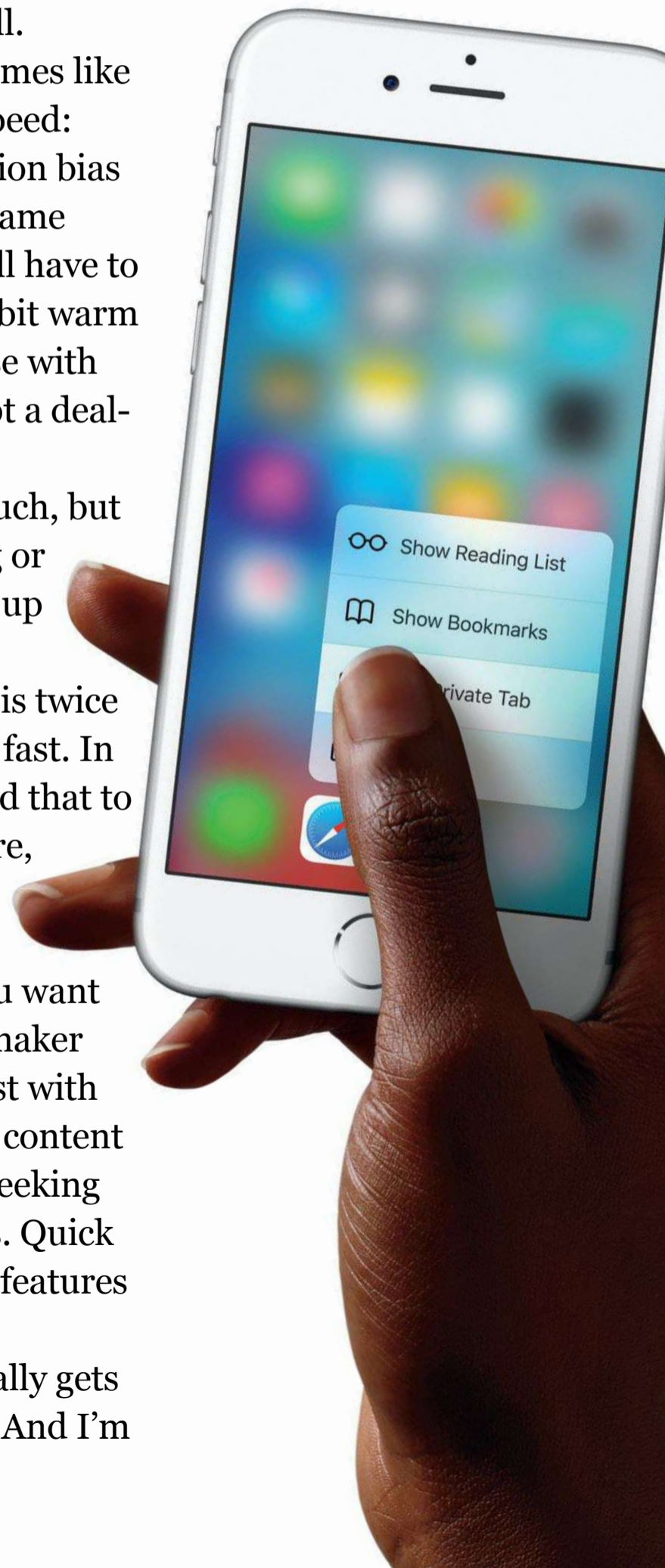

still discovering little Easter eggs, like how pushing down on the phone's virtual keyboard turns it into a cursor-positioning trackpad.

As for the rest of the phone's user interface, the iPhone 6s, like other current iPhones, runs iOS 9.

CAMERA AND LIVE PHOTOS

Apple makes two dramatic spec improvements to the iPhone's camera in the 6s. It bumps the main camera up from 8 to 12 megapixels, and the front camera up from 1 to 5MP.

The iPhone 6, iPhone 6s, and Samsung Galaxy S6 all perform delightfully outdoors in good light. I'd go further to say that the 6s' additional pixels give you more detail and more flexibility for cropping. I had serious trouble telling the difference between the 6s and Galaxy S6 images in my standard outdoor daytime test photos; maybe the 6s was a little better saturated, but not enough to matter.

In real-world conditions, the Galaxy S6 tends to get a little soft in low light, whereas the iPhone 6s delivered noticeably sharper photos with better detail. The extra megapixels bring out background detail that's quite noticeable when you download the image to a PC. With mixed lighting, on the other hand—low light with a window backlighting the scene—the Galaxy S6 balanced the exposure best, with both of the iPhones being too dim.

The new front-facing camera is significantly better than any previous iPhone's for two simple reasons: 1MP is just too tiny and grainy in this day and age, and the "front-facing flash" feature (which brightens up the screen to act like a flash, just as on the LG G4) makes selfies in dark rooms possible when they never were before.

But I was disappointed by the sharpness and quality of the front-facing camera images.

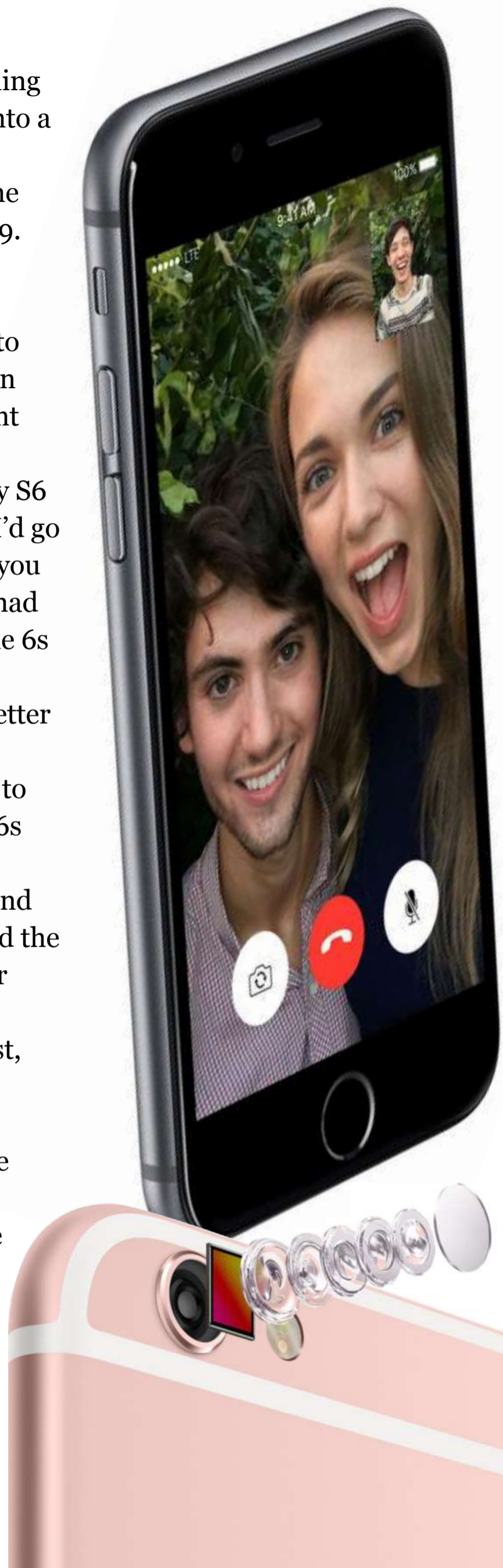



iPhone 6s Plus

From \$749



EDITORS' CHOICE

Size is 80 percent of the reason to buy an iPhone 6s Plus. If you're really into recording or viewing videos or playing mobile games, if you intend to use your phone as a sketchpad, or if you just have tired eyes, you'll want the 6s Plus instead of the smaller 6s. Excellent optical image stabilization for video capture and even faster LTE speeds further sweeten the deal. Average folks who are just looking for a large smartphone may be better off with the Motorola Moto X Pure, which costs \$399.99. But if price is no object, the iPhone 6s Plus is the most powerful phablet on the market.

—Sascha Segan

Especially in low light, they're blurry and noisy; they look like upscaled images from a lower-resolution sensor. Samsung's and LG's latest phones do much better. But the Samsung Galaxy S6 lacks the front-facing flash feature, which means in low light, there are a lot of images you'll be able to grab with an iPhone that aren't possible with the Galaxy.

Video quality has also been improved. Now you can capture 4K video at 30 frames per second (fps), which isn't on by default because those videos take up 375MB per minute. To really get the best videos, you have to get the oversized iPhone 6s Plus (see the sidebar on this page), because its optical image stabilization really keeps wobble out of the picture.

Live Photos is Apple's most aggressive new camera feature. On by default, it records 3-second H.264 videos (at 12fps) with every photo you take. It's a lot like HTC's Zoe feature, but because Apple enjoys a large market share, it's much more likely to be supported by third parties.

I found that Live Photos requires you to think of snapping pictures in a new way. You need to hold up the camera, and not be lifting or putting it down within 1.5 seconds of snapping your shot, or that gets captured; and because it records audio, you'll want to cut inappropriate chatter while taking snapshots. And right now, if you upload your photos to a third-party service like Dropbox, to a PC, or even to a Mac running any OS older than El Capitan, your library ends up cluttered with video files. (On the other hand, you can sew them together using iMovie, which is an intriguing idea.)

For now, you also can't share Live Photos through social media; they share as stills. Facebook has promised to support the format, and because Facebook owns Instagram, that may get the ball rolling later this year. But for now, I find Live Photos more of a curiosity than a must-use feature.



COMPARISONS AND CONCLUSIONS

If you're a T-Mobile iPhone user in a 700MHz coverage area who has had any problems with reception whatsoever, run to get this new iPhone. The improved modem makes a big difference in recovering from dead zones, the new Band 12 support noticeably improves LTE coverage, and the improved Wi-Fi is a better backup. Forget about 3D Touch and Live Photos and all that—the iPhone 6s is better at getting connected and staying connected.

If you take a lot of selfies, you can also go ahead and sell that iPhone 6. The 6s' front-facing camera could be sharper, but it's a huge step forward from the iPhone 6, especially with the new front-facing flash feature.

One thing's clear, though: Do not get the 16GB iPhone 6s. With Live Photos and high-res video devouring storage, you'll quickly run out of space, especially if you're the type who keeps all your media on your phone.

So that means you're looking at \$749, at least, for this phone. If you can't afford that, the iPhone 6 is still an excellent device. If that costs too much, you'll have to go with a less-expensive, high-quality Android phone.

As for the question of iPhone versus Android, the iPhone 6s and the Samsung Galaxy S6 have very comparable hardware at this point. They're roughly the same size. The Galaxy S6 has a larger, higher-resolution 5.1-inch screen, but not so much that the difference overwhelms you. More than ever before, it really comes down to whether you prefer Google's software or Apple's.

But when it comes to apps, especially games, there's still a gap. Many games aren't available on Android, and the more uniform nature of the iOS platform means a lot of small developers still turn there first. That's always been the case. It's not just Apple's excellent hardware, but the strength of the overall iOS ecosystem that makes the iPhone 6s worthy of our Editors' Choice award.

SASCHA SEGAN

**Microsoft
Surface Book**

\$1,699



The First PC Hybrid That Can Stand Up to a MacBook



Just when you thought that Microsoft would never make its own laptop, the company releases the Surface Book. Except it's not strictly a laptop—it's a powerful detachable laptop-tablet hybrid. Its innovative design and large, clear touch screen, as well as class-leading performance and more than 15 hours of battery life in our tests, make it well worth its hefty price.

DESIGN AND FEATURES

The Surface Book's silver-magnesium-alloy body has a premium look and feel similar to that of Apple's most recent 13-inch MacBook Pro, its most readily identifiable rival. In Laptop mode (when the keyboard is attached), the Surface Book tapers in thickness from 0.9 to 0.5 inch. Its length and width are 9.14 and 12.3 inches, respectively. The system weighs 3.34 pounds in Laptop mode; the

tablet alone weighs 1.6 pounds.

Detachable-hybrid tablets use a variety of latching mechanisms. The Dell Latitude 13 7350 and the Toshiba Portege Z20t-B2112 sport a simple sliding latch; the Lenovo ThinkPad Helix 2nd Gen has a mechanical push-button release; some less expensive models like the Acer Aspire Switch 11 have a magnetic latch. The Surface Book has a mechanical latch, but it's actuated electrically. When you hold the Detach button next to the Delete key on the keyboard, the tablet vibrates, a light on the keyboard turns green, and a window pops up to let you know it's safe to detach. This process only takes about 2 to 3 seconds. You can then use the screen the way you would a tablet.

The tablet clips back on just as easily, using metal spades and magnets for guidance. You can also clip it back on with the display facing the opposite direction in Display mode, which keeps the keyboard out of the way for better access to the touch screen. Because the Power button and the Volume control are on the part of the tablet that would rest on your table, we don't recommend using the system in Tent mode.

The 13.5-inch PixelSense screen has a 3:2 aspect ratio, which is larger than, but similar to, the Microsoft Surface Pro 4 tablet. PixelSense is Microsoft's branding for multitouch screens and the technology behind them. The system is designed to fit easily in the crook of your arm, with better balance than a tablet with a 16:9 aspect ratio, like the Latitude 13 7350 13 or the 11.6-inch ThinkPad Helix 2nd Gen.

The display is bright, with vivid colors even in a sunlight-filled room. It has an excellent 3,000-by-2,000 resolution, which is much higher than the 1,920-by-1,080 resolution of the Latitude 13 7350, the 2,560-by-1,440 resolution of the Lenovo LaVie Z 360, or the 2,560-by-1,600 resolution of the 13-inch Apple MacBook Pro. You'll be able to view photos,

Microsoft Surface Book

PROS Premium, versatile hybrid design. Brilliant high-resolution screen. Comfortable to use in Tablet mode. Electrically actuated mechanical latch. No bloatware. Offers long battery life.

CONS Pricy. No ports on tablet body. Does not lie flat when closed.

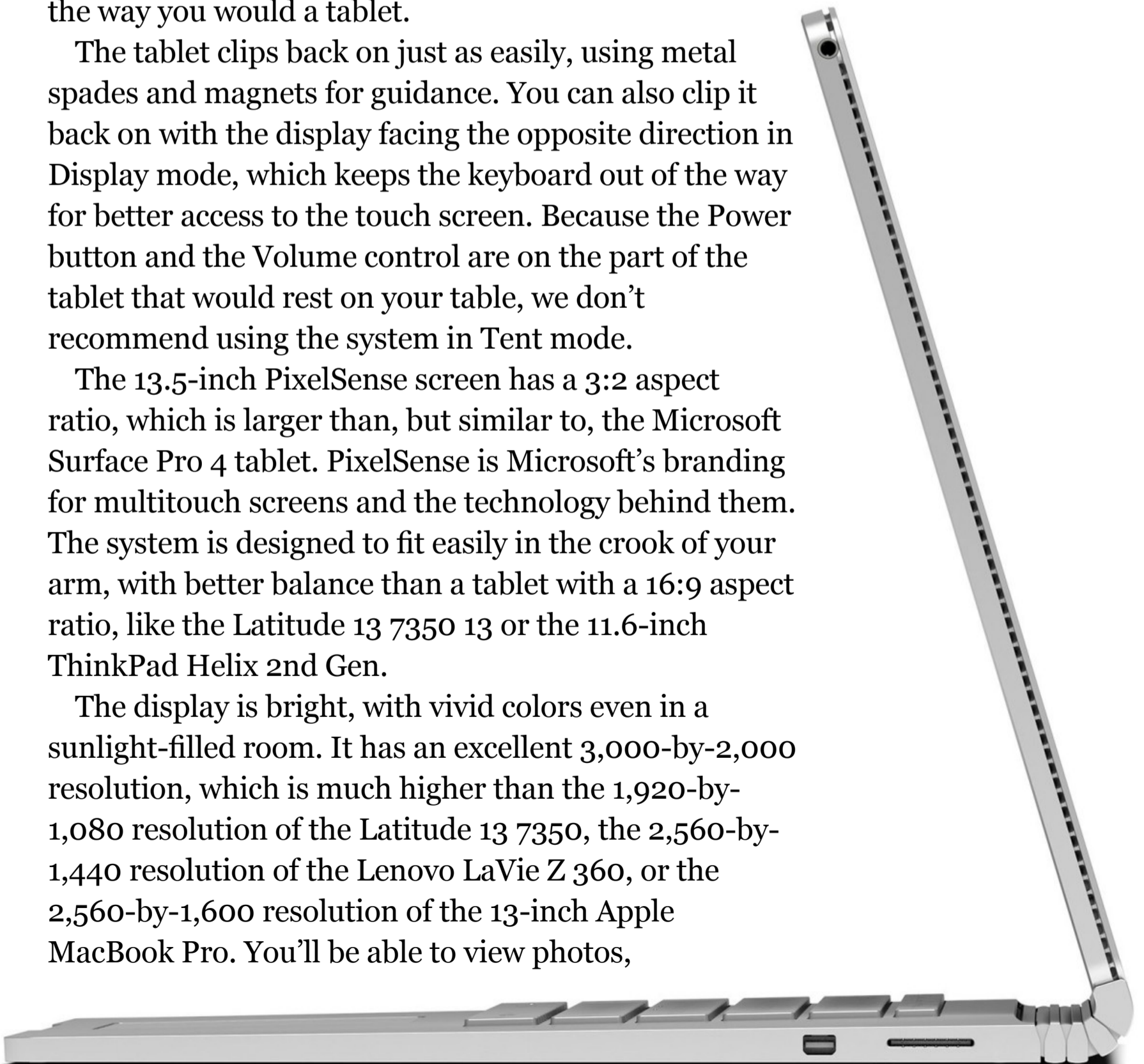

spreadsheets, and videos on the display without having to zoom in. Keeping multiple windows open side by side is easy on the big screen. You don't get 4K (3,840-by-2,160) resolution the way you do on the Toshiba Satellite Radius 15 P55W-C5212-4K, but you won't miss it unless you're a videographer shooting in 4K.

The backlit, chiclet-style keyboard is comfortable to type on. There's zero keyboard flex, and each key feels firmly attached. The one-piece glass-laminated touchpad is quick to respond to multitouch commands. The system's ten-point touch screen is equally responsive whether attached to or detached from keyboard.

The included Surface Pen attaches to the side of the screen magnetically, which is much more convenient than the fabric loop on the Surface Pro 3. As on the Surface Pro 4, the eraser-like button on the top of the Pen automatically brings up OneNote on the Surface Book with a single click, and opens the Cortana digital assistant if you hold the eraser for a second or two. The Surface Pen has 1,024 levels of pressure sensitivity, which is sufficient for prosumer-level artwork. It also varies the thickness of lines when you're writing, so you can write with delicate or bold pen strokes. Rubbing the eraser tip on the screen deletes those lines.

Good as Tablet mode is, we think you'll spend most of the time using the Surface Book as a laptop. It sports what Microsoft calls a dynamic fulcrum hinge, which flexes open using parallel hinges rather than a single hinge, as on traditional laptops. It's similar in spirit to the watchband-style hinge on the Lenovo Yoga 3 Pro, but more complex, wider, and without the full 360-degree multimode adjustment. The hinge prevents the screen from tipping over when open. Because the fulcrum point (and therefore the center of gravity) moves, the Surface Book is always balanced and stable on your lap or on your work surface.

The dynamic fulcrum hinge doesn't lie flat when closed, so you may have trouble stuffing the system into a crowded laptop bag. Microsoft tested the hinge to a compression

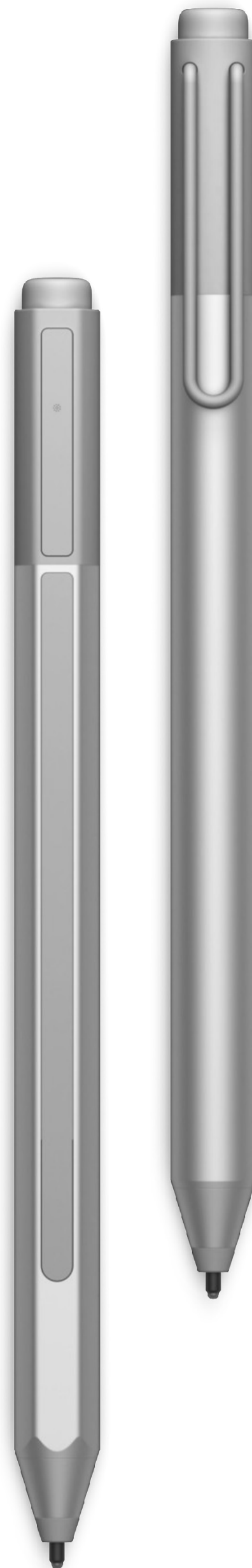

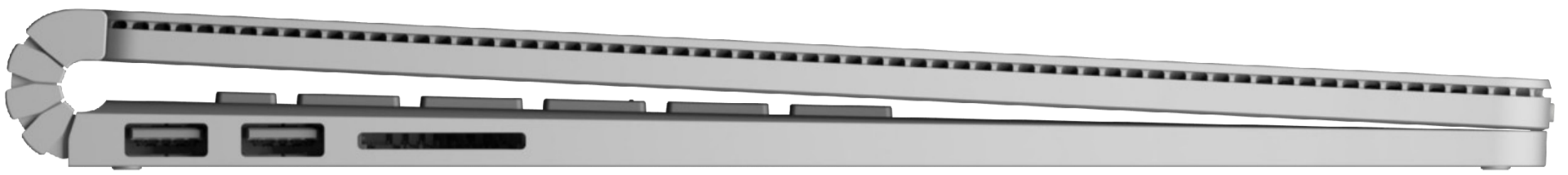

load of 40 pounds, so it's tough enough to survive your commute. It feels as sturdy as a normal laptop when you pick up the system by the screen or the base. The gap left by the hinge has an unexpected fringe benefit: The keys don't come into contact with the screen, so the keyboard isn't recessed as it is on most laptops. It's a subtle difference, but you'll feel more like you're typing on a desktop keyboard.

The tablet portion doesn't have any ports aside from a headset jack and its connector to the keyboard. The I/O ports are located on the keyboard portion, which reinforces the notion that you're going to be carrying both pieces around while traveling. The SD card reader and two USB 3.0 ports are on the left side, and a Mini DisplayPort jack and the Surface docking connector are on the right. There's a USB port on the power adapter, but it's only for charging. For extra connectivity, you'll need the separately available Surface Dock (\$199.99), which includes seven more ports: Ethernet, two Mini DisplayPort, and four USB 3.0.

The system has a front-facing 5-megapixel camera for selfies, Skype, and Windows Hello, and the rear-facing autofocus camera has an 8MP sensor. Both cameras can record 1080p HD video. Camera performance was good in testing, but pictures were a bit noisy in low-light conditions. Windows Hello, a security feature that lets you use facial recognition to log into your laptop just by looking at the camera, will be available later as an upgrade to Windows 10.

Our test configuration came with 8GB of memory and a 256GB solid-state drive (SSD). Thankfully, the SSD is unencumbered by bloatware; it contains only the Windows 10 OS. There are other configurations of the Surface Book available. The \$1,499 base model has 8GB of memory and the same Core i5 processor, but only 128GB of SSD space. Higher-priced models include one for



\$2,699 with 16GB of memory, a 512GB SSD, a discrete Nvidia GeForce GPU, and an Intel Core i7 processor. The top-of-the-line \$3,199 Surface Book upgrades the storage of the latter configuration to a 1TB SSD. In every case, the system comes with a one-year warranty.

PERFORMANCE

Our review unit was equipped with a brand-new 2.4GHz Intel Core i5-6300U processor. Because it uses a full laptop CPU, the Surface Book requires fan-assisted active cooling; the Intel Core M processors in the Latitude 13 7350, the Yoga 3 Pro, the ThinkPad Helix 2nd Gen, and the Toshiba Portege Z20t could be passively cooled. On the PCMark 8 Work Conventional test, the Surface Book returned an excellent score of 2,583, just behind the Z20t (2,607), and far ahead of the Yoga 3 Pro (2,094) and the ThinkPad Helix (2,083).

The Surface Book topped our multimedia tests with a time of 2 minutes, 20 seconds, on Handbrake and 3:07 on Photoshop. That beat the 13-inch MacBook Pro (2:38 on Handbrake, 4:17 on Photoshop), which has a slightly faster, albeit last-generation, 2.7GHz Intel Core i5 processor. The system also was competitive with the MacBook Pro on the CineBench R15 test (a score of 307 for the Surface Book, 311 for the MacBook Pro). Coming in at third place on the tests was the LaVie Z 360 (3:48 on Handbrake, 4:26 on Photoshop, 272 on CineBench); the rest of the Core M-equipped tablets and laptops took significantly longer across the board. The Surface Book is certainly capable of taking care of your photo and video editing needs at business, hobbyist, or prosumer levels.

The integrated Intel HD 520 Graphics delivered good 3D performance for the category. The Surface Book returned just-below-playable frame rates on the Heaven (22 frames per second, or fps) and Valley (25fps) game tests at medium

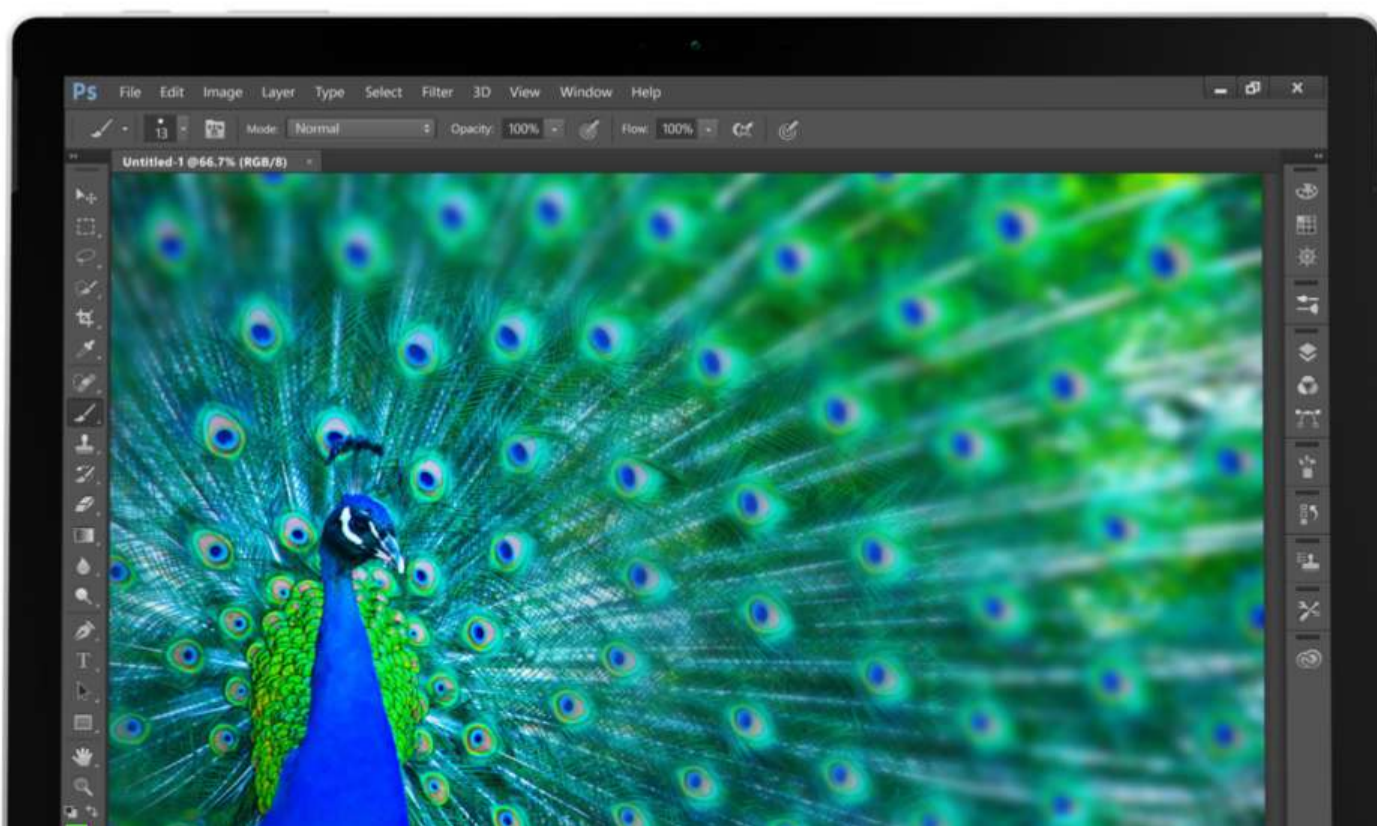



quality settings. Its scores on 3DMark Cloud Gate (5,842) and 3DMark Fire Strike Extreme (388) are top-notch compared with what we've seen from other detachable-hybrid tablets. With a bit of tweaking, you should be able to play AAA titles on the Surface Book at low to medium quality settings. Less-strenuous games should play smoothly at similar settings, even at full 3,000-by-2,000 resolution.

There are two batteries in the Surface Book: one in the tablet portion and another, larger one in the keyboard base. Together, they lasted a whopping 15 hours, 41 minutes, on our rundown test. That's hours longer than the ThinkPad Helix 2nd Gen (13:32), the Latitude 13 7350 (9:51), and the Portege Z20t (14:08) when connected to their respective keyboard bases. The Surface Book also outlasted traditional laptops like the 13-inch MacBook Pro (11:10). The tablet portion lasted 4:21 when detached from the keyboard, which was good, but it ran out a lot quicker than the 7 to 9.5 hours the other tablets lasted while detached. That reinforces the notion that the Surface Book is strongest when used as a laptop.

CONCLUSION

The Microsoft Surface Book compares well with the best premium laptops we've seen, with the added feature of a detachable screen. Sure, the dynamic fulcrum hinge is a bit fussy, but it solves more problems than it creates. This system's benchmark performance rivals that of our top ultraportable laptop, the 13-inch Apple MacBook Pro; it has an expansive screen that's usable in brightly lit rooms; it's very light in both Laptop and Tablet modes; and it's not loaded down with bloatware. Rivals like the Lenovo ThinkPad Helix 2nd Gen and the Toshiba Portege Z20t-B2112 cost a bit more, but offer lower performance, reduced battery life, smaller screens, and fewer features overall. It's therefore no surprise that we award the Surface Book our first Editors' Choice for high-end detachable-hybrid tablets.

JOEL SANTO DOMINGO

**Microsoft
Surface Pro 4**

\$1,299 (as tested)



From Microsoft, the Best High-End Tablet PC Yet



The Microsoft Surface line of tablets has been fairly divisive, with plenty of skeptics doubting the devices can truly replace a laptop for every convert who swears by the machine. Regardless, Microsoft is forging on with the fourth iteration, building the Surface Pro 4 on the strongest points of its predecessors. It's a significant improvement over the Surface Pro 3 in just about every way—for the same price—and a top-tier device on its own. Upgrades like a bigger, better display, the improved Type Cover and Surface Pen, and stronger battery life result in a superior system, and make it our Editors' Choice high-end slate tablet.

DESIGN AND FEATURES

Our review unit was one of the midrange Surface Pro 4 configurations, featuring a 2.4GHz Intel Core i5-6300U processor with integrated Intel HD Graphics 520, 8GB of memory, and a 256GB solid-state drive (SSD), all for \$1,299. There

are five other models, ranging from the \$899 version, with an Intel Core M3 processor, 4GB of memory, and 128GB of storage, to one with an Intel Core i7 CPU, 16GB of memory, and 512GB of storage for \$2,199.

The Surface Pro 4 measures 7.93 by 11.5 by 0.33 inches (HWD) and weighs 1.73 pounds, just slightly smaller and lighter than the Surface Pro 3 (which measures 8 by 11.5 by 0.36 inches and weighs 1.75 pounds). The Surface Pro 4 actually packs a larger display into its smaller frame—12.3 inches compared with 12 inches—by decreasing the bezel size. Like the Microsoft Surface Book, the Surface Pro 4 has a body made of high-quality silver-magnesium alloy, and the back is adorned with a mirrorlike Windows logo.

The adjustable kickstand is mostly the same as it was on the Surface Pro 3 (not a bad thing, as the Pro 3's felt good and worked well), but it feels sturdier and can be adjusted a little more easily. It's useful for propping up the system on your lap or at a table, though it can't replicate a traditional typing experience without the Type Cover. That peripheral is not included and will cost you \$129.99 if you want the Surface Pro 4 to truly serve as a laptop replacement.

The stand can be easily adjusted to find the most comfortable position, which is especially useful if you're using the system on your lap. I've personally never found balancing a Surface device on my lap for typing any more awkward than with a traditional laptop, and the kickstand's edge has been rounded out to help prevent it from digging into your legs, which was an issue with previous Surface Pro models. When it's flat against the system in Tablet mode, the stand can be a little difficult to get a hold of and extend naturally, even with the indents in the sides.

The display has a 2,736-by-1,824 resolution and comes with Microsoft's new PixelSense technology, which provides high contrast and reduces glare. The display looks brilliant and is extremely bright, with rich

Microsoft Surface Pro 4

PROS Sharp, vibrant touch display. Full-friction, adjustable kickstand. Improved Surface Pen, Type Cover from previous iteration. Strong battery life in testing.

CONS Pricy. Type Cover sold separately. Only one USB port.



colors, sharp text, and crisp video. The adjustable stand works well in conjunction with the display, letting you find the best angle depending on how you're seated without a loss in picture quality.

Using the Surface Pro 4 as a tablet is comfortable enough, though your mileage may vary on how you feel holding it in the crook of one arm. I didn't find my arm tiring especially quickly, and the included Surface Pen goes a long way in making using the tablet that way more viable. As with the Surface Pro 3, clicking the eraser button on the Surface Pen brings up OneNote instantly. You can also double-click the Surface Pen to take a screenshot, which you can crop and draw on right away in OneNote. Holding down the eraser button now also brings up the Cortana digital assistant.

Typing on a virtual keyboard is never ideal, and the Surface Pen can take your real handwriting and turn it into text. In testing, this feature was a bit hit and miss; it greatly depends on the neatness of your penmanship, but it gets the job done once you learn the shortcuts. The Surface Pen feels good on the touch screen, with a real sense of pressure (line thickness changes depending on how hard you press) and a working eraser. The somewhat silly loop for storing the pen on the Surface Pro 3's Type Cover is gone; instead, you can attach the pen magnetically to the left or right side of the Surface Pro 4.

This Type Cover is superior to the last iteration in every regard. The backlit keys are more spread out, and they have better travel to boot. In particular, the touchpad is hugely improved: It's bigger and more sensitive, and it feels a lot smoother to scroll across. The magnetic latch that secures the keyboard to the display (introduced on the Pro 3 Type Cover) for use on your lap is even more



SURFACE TENSION

The Surface Pro 4 is a fine addition to Microsoft's tablet line, with improved performance, a better screen, and longer battery life than the Surface Pro 3.



JUST YOUR TYPE

A number of colorful Type Covers are available for use with the Surface Pro 4, but none comes included with the tablet—you'll have to pay \$129.99 for one.

secure than in the previous iteration, and the Type Cover is also lighter at 10.2 ounces. The new Type Cover works with the Surface Pro 3, and vice versa.

The Surface Pro 4 features Windows Hello, facial-recognition software that's built in to Windows 10 and is beginning to appear on devices made for the new OS (though as of this writing not available on our system). Windows Hello can save you the trouble of typing in a password every time you reach for the device, and to prevent anyone who isn't you from logging in. There's also an 8-megapixel, rear-facing camera that can record in 1080p. The image quality of photos is good—not great—but videos recorded with the rear camera were particularly sharp in testing.

On the right side are a USB 3.0 port, a Surface Connect port for the new Surface Dock, and a microSD card reader; on the left side is the headphone jack. The Power button and the Volume rocker are on top of the tablet, and the port for the keyboard is on the bottom. It's disappointing that Microsoft chose to stick with just one USB port, which is an issue we had with the Surface Pro 3.

The Surface Pro 4 features stereo Dolby speakers, which don't have visible grilles and instead produce sound from the interior of the machine and through the ventilation. They can get pretty loud, and don't lose quality at high volumes. There is also an accelerometer and a gyroscope. For wireless connectivity, the system comes with 802.11ac Wi-Fi and Bluetooth 4.0. Microsoft backs the Surface Pro 4 with a one-year warranty.

PERFORMANCE

Because of its processor and RAM, our Surface Pro 4 was very snappy during both boot-up and regular use. Its displayed solid productivity performance, earning a score of 2,612 on the PCMark 8 Work Conventional test. This puts it in line with similarly priced systems, like the Asus Transformer Book T300 Chi (2,615) and the Lenovo ThinkPad Yoga 14 (2,410). The Surface Pro 3 scored slightly higher (2,699) than the Pro 4 on this test, which is likely due to its lower-resolution display.

The Surface Pro 4 completed our Handbrake video encoding test in 2 minutes, 20 seconds, beating out the Surface Pro 3 (2:59) and the 13-inch Apple MacBook Air (2:49). Its time of 3:10 on the Adobe Photoshop CS6 test was also much quicker than the Surface Pro 3's 4:48, and the MacBook Air's 5:13. The Surface Pro 4 scored 307 on the CineBench test, besting both the Surface Pro 3 (255) and the Transformer Book T300 Chi (254).

Although the Surface Pro 4 will never be ideal for enthusiast gamers, it is competent enough to run some games under some circumstances. In the Heaven and Valley 3D tests at medium quality settings and 1,366-by-768 resolution, it returned results of 21 frames per second (fps) and 23fps, respectively, just below what we consider playable frame rates. Still, you should be able to play some slower-paced games like Civilization or Football Manager—just don't expect to run the latest action games at high quality.

Battery life is perhaps where the Surface Pro 4 shines most. It lasted 10 hours, 19 minutes, on our rundown test. This is a big jump up from the already excellent 8:55 battery life of the Surface Pro 3, and significantly longer than what we saw from the Transformer Book T300 Chi (5:54) and the ThinkPad Yoga 14 (6:13). The 13-inch MacBook Air is still the clear leader in battery life, however, lasting an impressive 17:36.

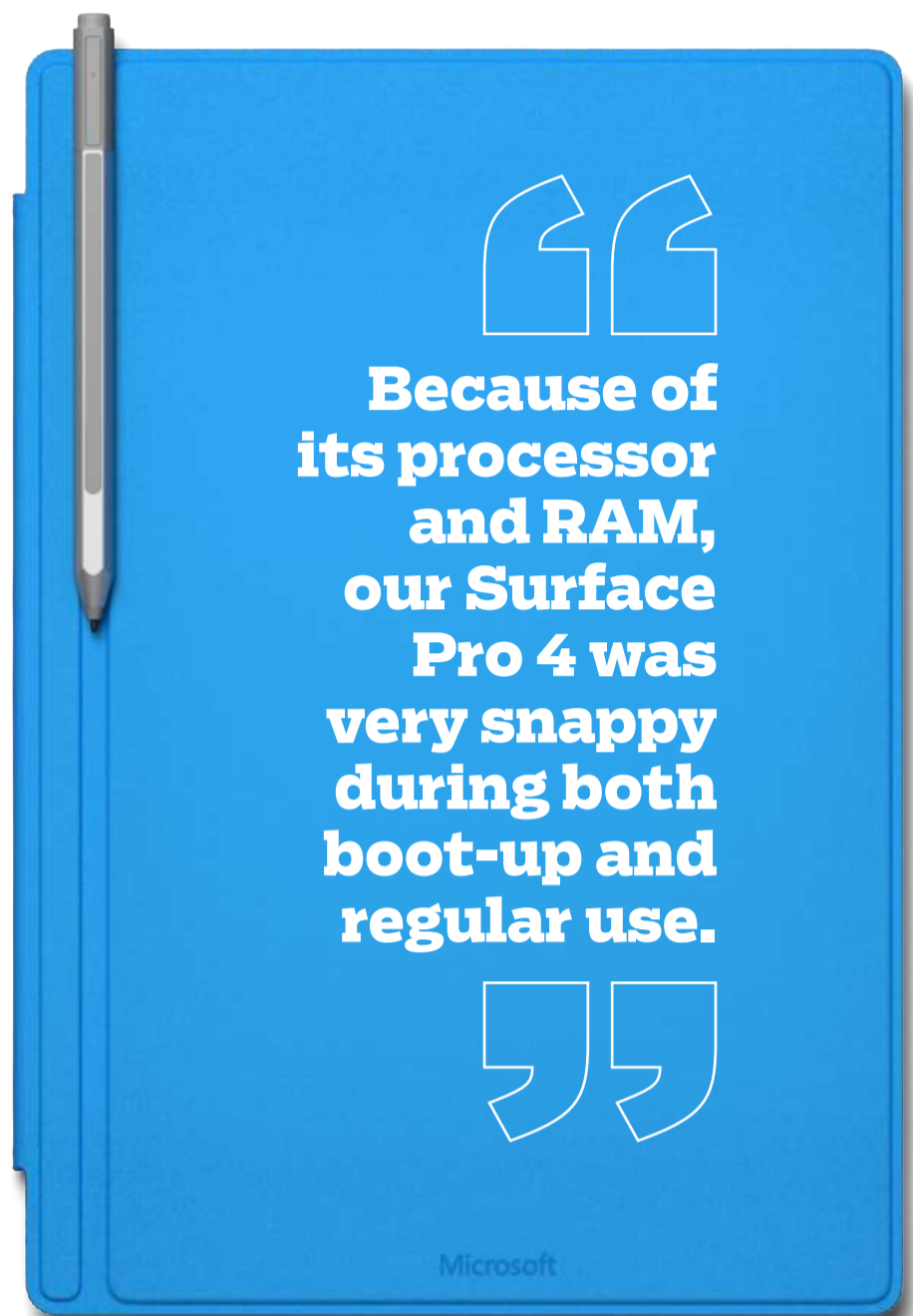



MIGHTIER THAN THE SWORD

Like the Type Cover, the Surface Pen is available in a range of colors. Want more customizability? The Surface Pen Tip Kit lets you select the tip that feels most natural and comfortable to you.



CONCLUSION

The Microsoft Surface Pro 4 is a refined, versatile system that can accomplish almost any task you would ask of it in day-to-day use. The tablet runs full Windows 10 smoothly, and the kickstand and the Surface Pen are better than they've ever been for working on the go. The only obvious aspect of a traditional laptop missing while using the Surface Pro 4 is a keyboard, which can be addressed if you're willing to lay down the extra money for the Type Cover. That does add to the system's price, but it gives the Surface Pro 4 the full functionality of a laptop. Although the tablet and Type Cover together cost \$300 more than Apple's 13-inch MacBook Air, the Surface Pro 4 also gives you tablet functionality and a touch screen with a higher resolution than the non-touch display on the Apple laptop. All of this is why the Surface Pro 4 is our Editors' Choice high-end slate tablet.

MATTHEW BUZZI



Chrome Powers This All-in-One Touch-Screen Desktop

The Acer Chromebase DC221HQ bwmicz provides a large display and speedy hardware for Google's Web-centric Chrome OS operating system. This all-in-one desktop, one of only two we've seen so far (the other was the LG Chromebase), is easy to use and packs a 1080p touch screen and quick performance at a low price. You can find better entry-level systems, but Acer's Chromebase is capable and affordable.

**Acer
Chromebase
DC221HQ
bwmicz**

\$329.99 (as tested)



DESIGN AND FEATURES

The Chromebase DC221HQ is a sleek, white all-in-one with a speaker grille stretched along the bottom of the frame. The articulating stand lets you tilt the display until it's almost horizontal, so you can interact with the touch screen easily. If you pull the screen back toward you, the spring-loaded stand will prop itself back into an upright position.

The 21.5-inch, LED-backlit touch screen has a 1,920-by-1,080 resolution. A sharper In-Plane Switching (IPS) display without touch capability, as seen on the LG Chromebase, may have been a more appealing trade-off. Touch support is useful for some applications, but it's not a must-have for the Chrome OS.

The display is fairly reflective, but image quality is good. You can actually use the Chromebase as a standalone monitor once the system has outlived its usefulness, thanks to the HDMI port on the back. There are also two USB 2.0 ports and an Ethernet port. A rear panel pops off to reveal a USB 3.0 port, an SD card slot, and the audio jack, which is somewhat inconveniently placed for headphone use.

Bluetooth 4.0 and 802.11a/b/g/n wireless are integrated, and the system comes with a white wired mouse and keyboard. Wireless peripherals would have been a better fit, as the keyboard and mouse will take up two of the three USB ports on the system.

Although using Chrome OS means you lose out on traditional Windows programs, it's not without its advantages. You use your Google account to log in to the system, and doing so will sync and apply your global preferences to the Chromebase DC221HQ. This means your Google Docs, Drive, and email will be instantly accessible, and ease of use like that is hard to beat—as long as you have an Internet connection, that is. Acer offers a one-year limited warranty on the system.

Acer Chromebase DC221HQ bwmicz

PROS Affordable.
1080p touch screen.
Articulating stand.
Simple to set up, use.
Quick performance.

CONS Limited number of USB ports.
Only 16GB of local storage. Wired mouse, keyboard.





TOUCHING BASE
The affordable Acer Chromebase DC221HQ has a 1080p touch screen, but limited USB ports and local storage.

PERFORMANCE

The Chromebase DC221HQ has a 2.1GHz Nvidia Tegra K1 quad-core processor and 4GB of RAM. There's only 16GB of onboard storage, but Acer bundles in 100GB of space on Google Drive for two years, after which it will cost you \$1.99 per month.

Given that the system can't run Windows programs such as Microsoft Word, you'll need to use Google Docs and Sheets, but everything is quick and simple as long as you're connected to a network. Load times are short, with slight slowdowns evident only when streaming high-quality video while simultaneously running multiple tabs.

For everyday use and the simple browsing that the system is built for, the Chromebase DC221HQ is snappy. If you have a slow network or any connectivity problems, the experience may be a little sluggish, but a broadband connection should serve you well. The hardware is superior to that of both the LG Chromebase and the Asus Chromebox M004U, but it still isn't powerful enough to perform any tasks beyond video streaming and basic Chrome app gaming. Fortunately, those are the most straining tasks possible on Chrome OS. Our Editors' Choice system, the Lenovo C260 Touch, is more robust, with full Windows, a quad-core Intel Pentium processor, and a 500GB hard drive, but the Chromebase DC221HQ is efficient with what it can do.



CONCLUSION

The Acer Chromebase DC221HQ bwmicz is an affordable, Web-enabled all-in-one desktop that doesn't stand out in any one particular area. It's a good option if you spend most of your time working in the cloud and have constant access to a network. The touch screen isn't necessarily any easier for browsing than a mouse, though there may be plenty of home and commercial setups that can utilize the system as a quick-stop terminal rather than a full PC replacement. The Chromebase DC221HQ does offer better hardware than LG's first stab at a Chrome OS all-in-one, and at a slightly lower price. The Asus M004U desktop is even less expensive (\$179), though it's not as powerful and lacks the Acer model's built-in display or peripherals. Although it's \$150 pricier than the Acer Chromebase, the Lenovo C260 Touch remains our Editors' Choice entry-level all-in-one desktop due to its full Windows compatibility, strong performance, and plentiful storage.

MATTHEW BUZZI



Bring 802.11ac Speed to Any PC With D-Link's Adapter



If you've recently upgraded to an 802.11ac router but are still using older Wi-Fi adapters in your PCs, you're not realizing the full potential of your new router. Retrofitting your desktop clients with an internal 802.11ac adapter can be daunting, and with most laptops it is virtually impossible. Enter the D-Link AC1900 Wi-Fi USB 3.0 Adapter (DWA-192). It's relatively large and it doesn't come cheap, but this dual-band 802.11ac Wi-Fi adapter uses a USB port to deliver outstanding throughput across a solid range.

DESIGN AND FEATURES

Most USB network adapters are USB sticks that protrude around a few inches out of the USB port and can easily go wherever your laptop does. The DWA-192, on the other hand, is an orb that connects to your USB port via an included proprietary 3-foot USB cable. About the size of a baseball, the adapter measures 3.15 inches in diameter and weighs 10.4 ounces—not overly huge, but certainly larger and less portable than a USB stick.

The DWA-192 has a black top and a flattened silver base that keeps the adapter from rolling off of your desk. The two halves of the orb are separated by a thin LED ring that glows solid blue when the adapter is properly connected and blinks blue when it loses connectivity. The base contains a

**D-Link AC1900
Wi-Fi USB 3.0
Adapter
(DWA-192)**

\$129.99



connector for the USB cable, a button that turns the LED ring on and off, and a Wireless Protected Setup (WPS) button.

The DWA-192 is a dual-band AC1900 adapter capable of maximum speeds of 600Mbps on the 2.4GHz band and 1,300Mbps on the 5GHz band. It supports 802.11a/g/n connectivity and WPA, WPA2, and WPS security. It also supports D-Link's SmartBeam (Beamforming) technology, which directs wireless signals directly toward the router rather than in a broad spectrum. The adapter ships with a CD containing installation software and a User Guide, a Quick Install guide, and the USB cable.

INSTALLATION AND PERFORMANCE

Setting up the DWA-192 is fast and easy. First, make sure you've disabled any installed Wi-Fi adapters on your PC using Device Manager. Next, install the software on your client PC and plug the adapter into the system's USB port when prompted. The light ring will flash blue while the software loads. When the software setup is completed about 30 seconds later, connect the DWA-192 to your router's 2.4GHz or 5GHz radio band, and you're ready to go.

The DWA-192 delivered stellar throughput and range. On my 2.4GHz close-proximity (same-room) test, it delivered an average throughput speed of 228Mbps,

D-Link AC1900 Wi-Fi USB 3.0 Adapter (DWA-192)

PROS Easy to install.
Excellent throughput speeds. Good range.

CONS Expensive.
Bulky.

EASY INSTALL
Simple installation procedures ensure that you'll get the D-Link AC1900 Wi-Fi USB3.0 Adapter up and running quickly.





trouncing the Edimax AC1200 (82Mbps), the Totolink A2000UA AC1200 Wireless Dual Band USB Adapter (35Mbps), and the Asus Dual-band Wireless AC1200 USB Adapter USB-AC53 (57Mbps) by 100 points or more. It also beat my laptop's integrated Qualcomm Atheros QCA9377 wireless 802.11ac network adapter (106Mbps) by a wide margin. At a distance of 30 feet, the DWA-192 delivered 108Mbps, compared with my laptop adapter's speed of 62.2Mbps and the Edimax AC1200's speed of 43Mbps. The Totolink A2000UA managed just 33Mbps.

Performance on the 5GHz band was also remarkable. The DWA-192 produced an impressive 352Mbps on the close-proximity test and 183Mbps on the 30-foot test. My integrated laptop adapter stayed close on the close-proximity test (325Mbps), but lagged behind in the 30-foot test (86.4Mbps). The Totolink A2000UA trailed the pack with results of 37Mbps on the close-proximity test and 41Mbps on the 30-foot test, and the Edimax scored 197Mbps and 158Mbps, respectively. And although the DWA-192 is a USB 3.0 adapter, I detected no throughput loss when it was connected to a slower USB 2.0 port.

CONCLUSION

The D-Link AC1900 Wi-Fi USB 3.0 Adapter (DWA-192) may cost more than adapters such as the Edimax AC1200 Wireless Dual-Band Adapter and the Totolink A2000UA AC1200 Wireless Dual Band USB Adapter, but it offered superior throughput and range to compensate. It looks cool and is easy to install, but it takes up a fair amount of space and can be a hassle when moving from room to room. That said, for increasing your Wi-Fi throughput without replacing your current wireless hardware, the DWA-192 is your best bet.

JOHN R. DELANEY



Microsoft Office 2016

\$69.99 to \$149.99
(price varies by version)



Collaboration Is Easier Than Ever With Office 2016



Microsoft made massive changes in Office 2016 for Windows but has hidden most of them beneath a reassuringly familiar-looking surface. As always with Microsoft Office, this new version is vastly better than anything else out there, and only a few advanced users of the world's most powerful and widely used office application suite will find odd corners of inconvenience that Microsoft hasn't bothered to fix.

INDIVIDUAL ADDITIONS

A fair amount is new in Office's traditional big three apps: Word, Excel, and PowerPoint. A major new convenience is a "Tell me what you want to do" box on the top-line menu that lets you search for a feature without having to open

various ribbon tabs. You either click in the Tell Me box or type Alt-Q to start typing in the box, and a drop-down menu lists likely matches for the words you type.

Another new online research feature is Smart Lookup, which opens an Insights pane at the right of the screen with two tabs: Explore, containing Wikipedia and other Web-search information on the currently selected text, and Define, showing definitions from the Oxford dictionaries. This pane is a supercharged Web-based update of the older Research feature that disappeared from the interface in Office 2013 (though that one is also still available).

The entire Office 2016 user interface gets the vivid solid-color treatment familiar from Windows 10, and you can now choose a black background for the menu that helps you focus your attention on your document instead of on the application. The top-line menu also features some minor tweaks like lowercase labels on tabs.

Word continues to make it easier to create highly styled documents using Microsoft's suggested headline styles than to create your own custom layouts. Corel WordPerfect is the only current word processor that offers more straightforward controls over formatting, but WordPerfect remains a niche product used almost entirely by long-term loyalists and legal users who need its special features.

Microsoft has learned that Excel users love charts, so 2016 includes some showstoppers formerly available from third-party add-ins: Pareto charts, sunbursts, and waterfall charts that show the effects of cumulative changes in a series of floating blocks. Expert Excel users know the laborious trick of building a waterfall chart by making the lower part of a block invisible, but Microsoft's one-click version is a lot more elegant.

Among rival spreadsheet programs, only Apple's Numbers offers comparably good-looking charts, but in far fewer types, and Google Docs and LibreOffice 5 have

Microsoft Office 2016

PROS World's most powerful office suite. Upgraded with the best collaboration features anywhere. Minimal interface changes from 2013 version. Monthly updates with new features for Office 365 subscribers. Consistent interface on all platforms.

CONS Little-used features that were awkward in past versions still aren't fixed. Traditional standalone copies won't get the same updates that Office 365 subscribers will get automatically.



only a bare-bones selection—though Google’s charts display Google’s characteristically simple elegance.

Microsoft promises to add new chart styles every month for Office 365 subscribers. Meanwhile, Excel gets a built-in Forecasting feature that creates forecast charts based on existing data, and gee-whiz graphic features like an animated transformation of one chart type to another when you decide to use a different charting style.

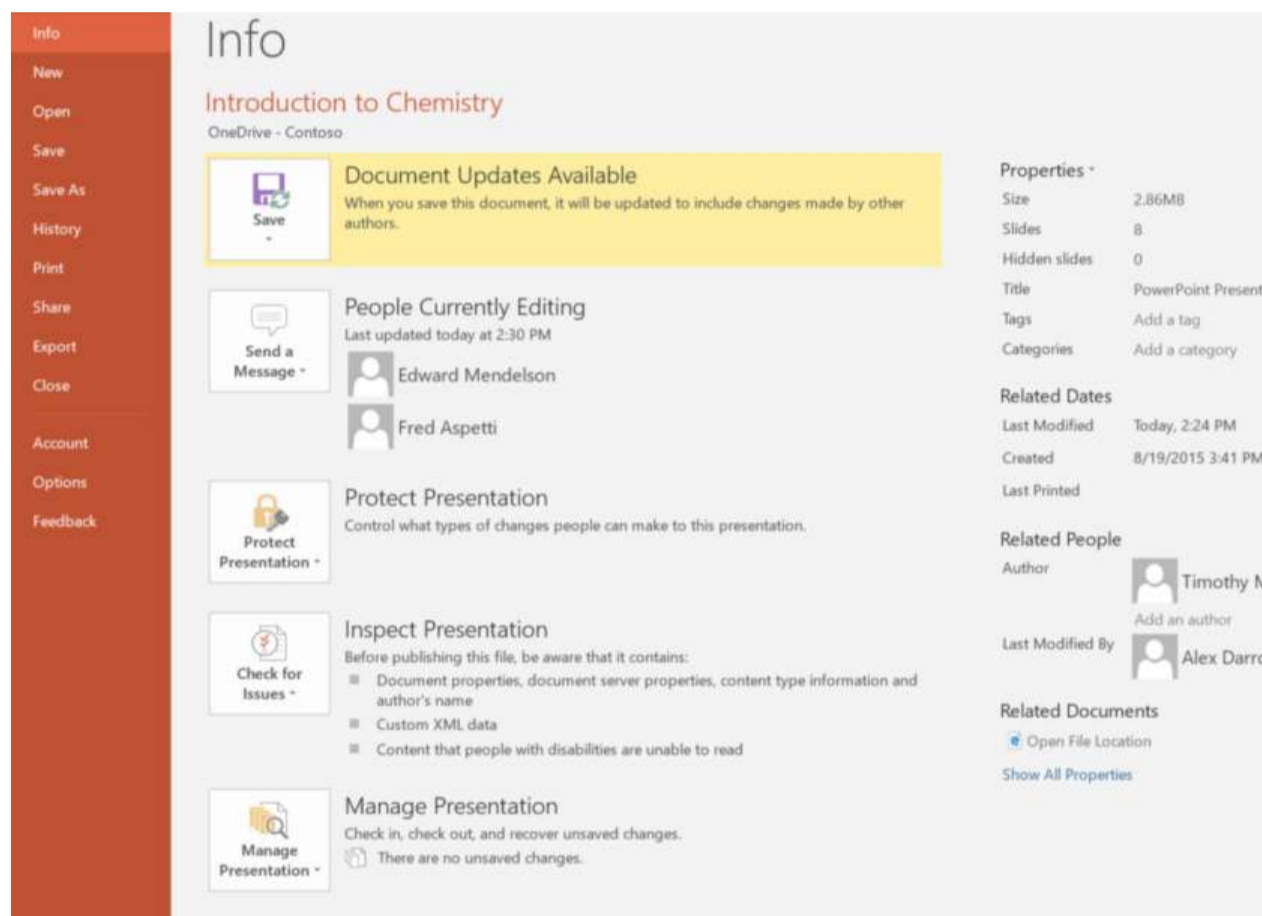

PowerPoint hasn’t had any major changes on its own, but a Microsoft rep hinted that some big new PowerPoint features will be coming to Office 365 subscribers in the relatively near future. Meanwhile, PowerPoint slightly lags behind Apple’s Keynote in graphic razzle-dazzle, but not enough to make anyone choose Apple’s iWork over Microsoft Office as their preferred office suite.

LEARNING TO SHARE

The other big new feature on Office’s top-line menu is the Share button at the far right. This opens a sharing pane (or, if you prefer, a floating menu) in which you

FAST FACT

Office 2016 for non-business customers is available to users of the subscription-based Office 365 for \$6.99 per month (or \$69.99 per year) for use on one PC or Mac, one tablet, and one phone; or for \$9.99 per month (or \$99.99 per year) for use on five PCs or Macs, five tablets, and five phones. It may also be purchased as a standalone product for PC or Mac for a one-time price of \$149.99. The benefits of Office 365 include monthly feature updates and new chart styles for Excel, along with other enhancements as they’re developed. Buy the standalone Office 2016 and, aside from the usual bug fixes and security updates, that’s what you’re stuck with.

can invite collaborators to view or edit your document, and multiple users can now edit the same document at the same time. It's easy to fine-tune permissions for collaborative editors or control sharing, and you can even send a Skype IM to a remote user from within a document.

Office seems to block two users from editing the same sentence or paragraph at the same time, though this wasn't consistent in my testing, and sometimes the two versions of the document took more than a minute to get into sync.

As you'd expect, collaborative documents must be stored on a Microsoft cloud server, either OneDrive, OneDrive for Business, or an Office 365 SharePoint site. One benefit of storing documents in Microsoft's cloud services is that you get easy access to previous versions, as in Google Docs, including the names of the different editors who saved collaborative documents at different times. A new History tab on the File menu opens a pane that lists saved versions; click on an item in the list, and that previous version opens in a new window so you can edit it as a separate file or copy text and graphics into the current version.

Outlook gets the most thorough makeover to accommodate Office's collaboration features, and some new features are only visible if you use an Office 365 Business account or SharePoint services, though other new features are available to anyone with a Microsoft account, business-level or not.

One feature available to everyone lets you attach a link to a file on your OneDrive drive instead of attaching the file itself, and do this with a single click. When you click the

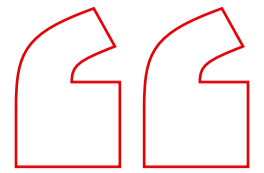

Outlook gets the most thorough makeover to accommodate Office's collaboration features.



UPLOAD CENTER UPDATES
Given Office 2016's new collaboration features, you're likely to get more use than ever out of the handy Upload Center upload tracker.

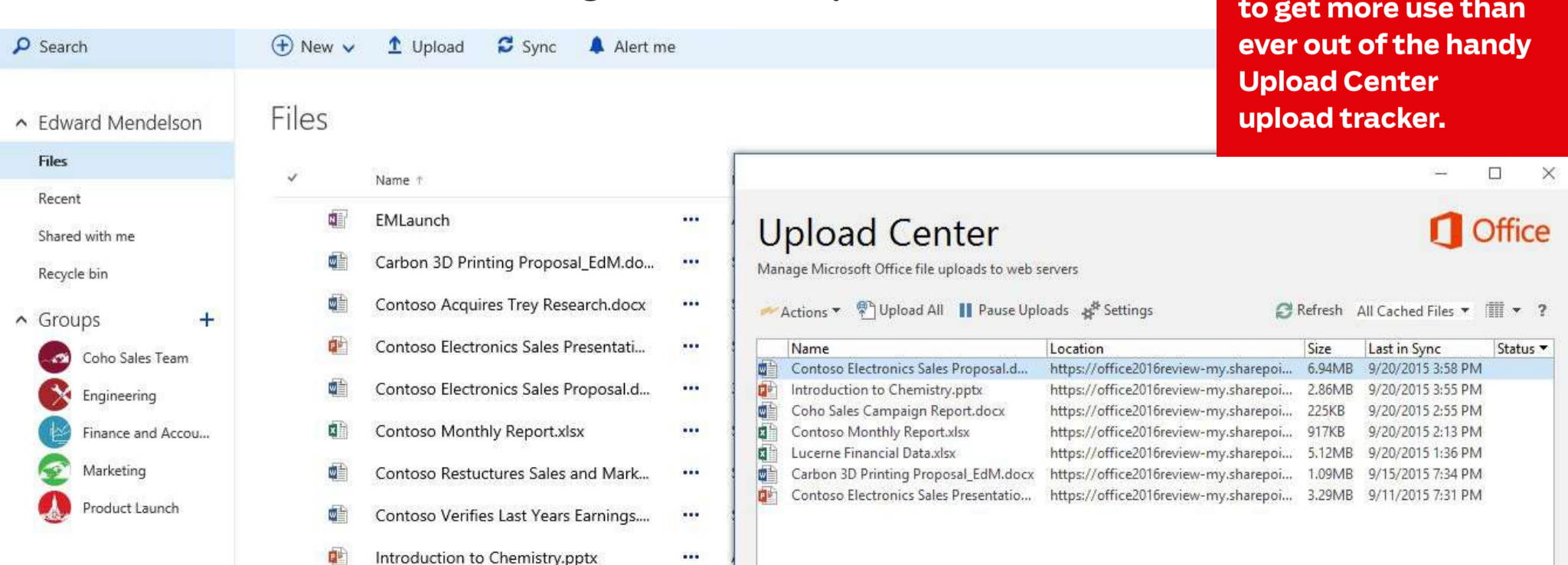

Attach File button while composing a message, Outlook displays a list of your recently edited documents. Click on a document stored in OneDrive and Outlook inserts a live link to the cloud-based file (although you can easily attach the actual file instead, if you prefer). This reduces bulk in mail messages and means the file the recipient opens will always be the most recent version.

For enterprise-level Office 365 Business accounts, Outlook offers a Groups feature through which team members can message the group and effortlessly share files and calendars. Group members can opt to receive messages in their inbox or only get them when they click on a Groups heading in the left-hand sidebar. The group-messaging feature resembles multi-user IM services like Slack—you can type a message for everyone in the group—but because it's built into Outlook, you can insert or consult calendars, notes, contact information, or any other Outlook item.

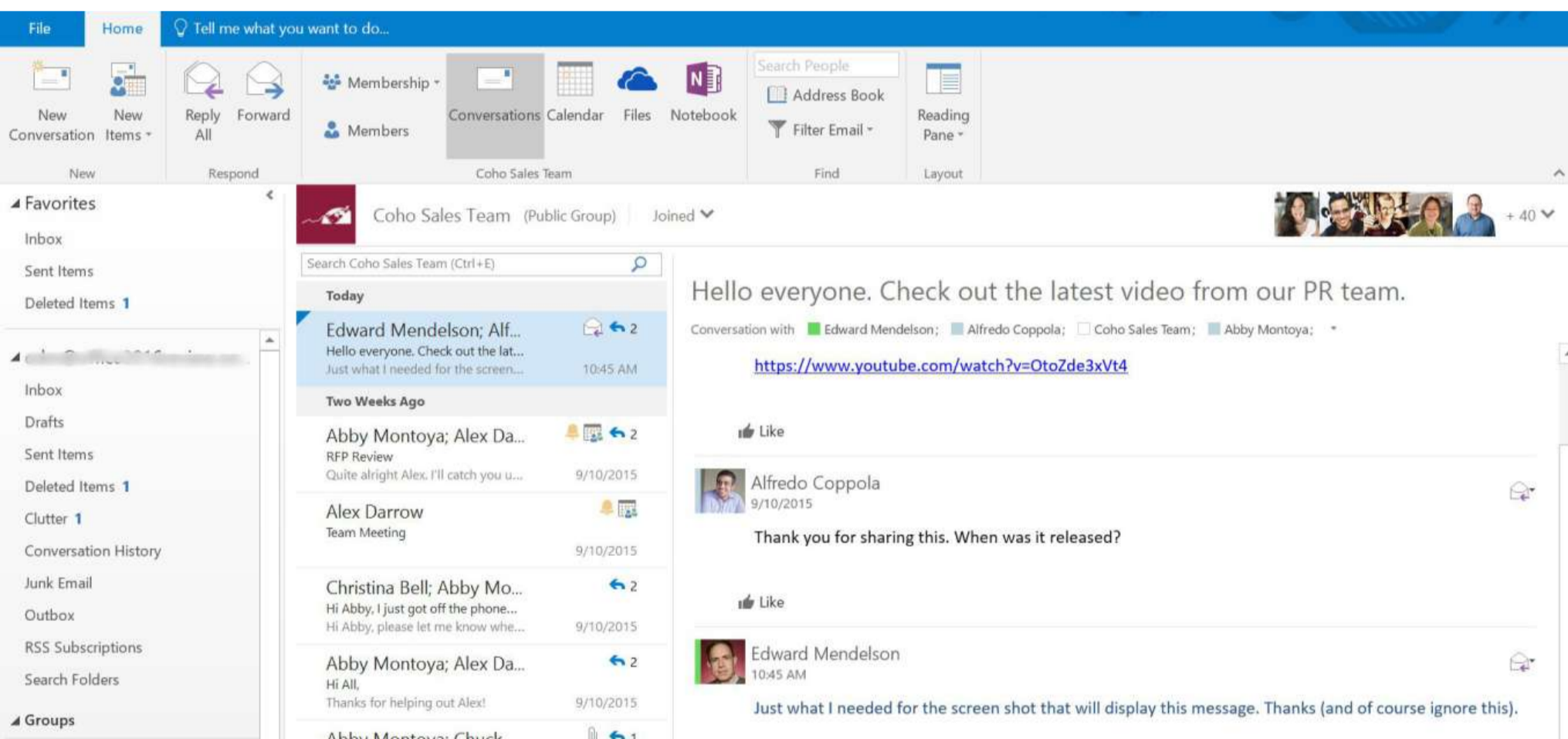

Also, for Enterprise-level accounts, an optional Clutter feature cordons off into a special folder those messages that it thinks you don't care about because you've typically ignored the senders in the past. It's like a higher-tech, enterprise-level counterpart of the third-party SaneBox service I rely on to keep low-priority messages out of my personal inbox. Also nice: handwriting support for equations, so tablet users can draw an equation on a touch screen and see Office transform it into typeset form—impressively but not always perfectly accurately in my testing.

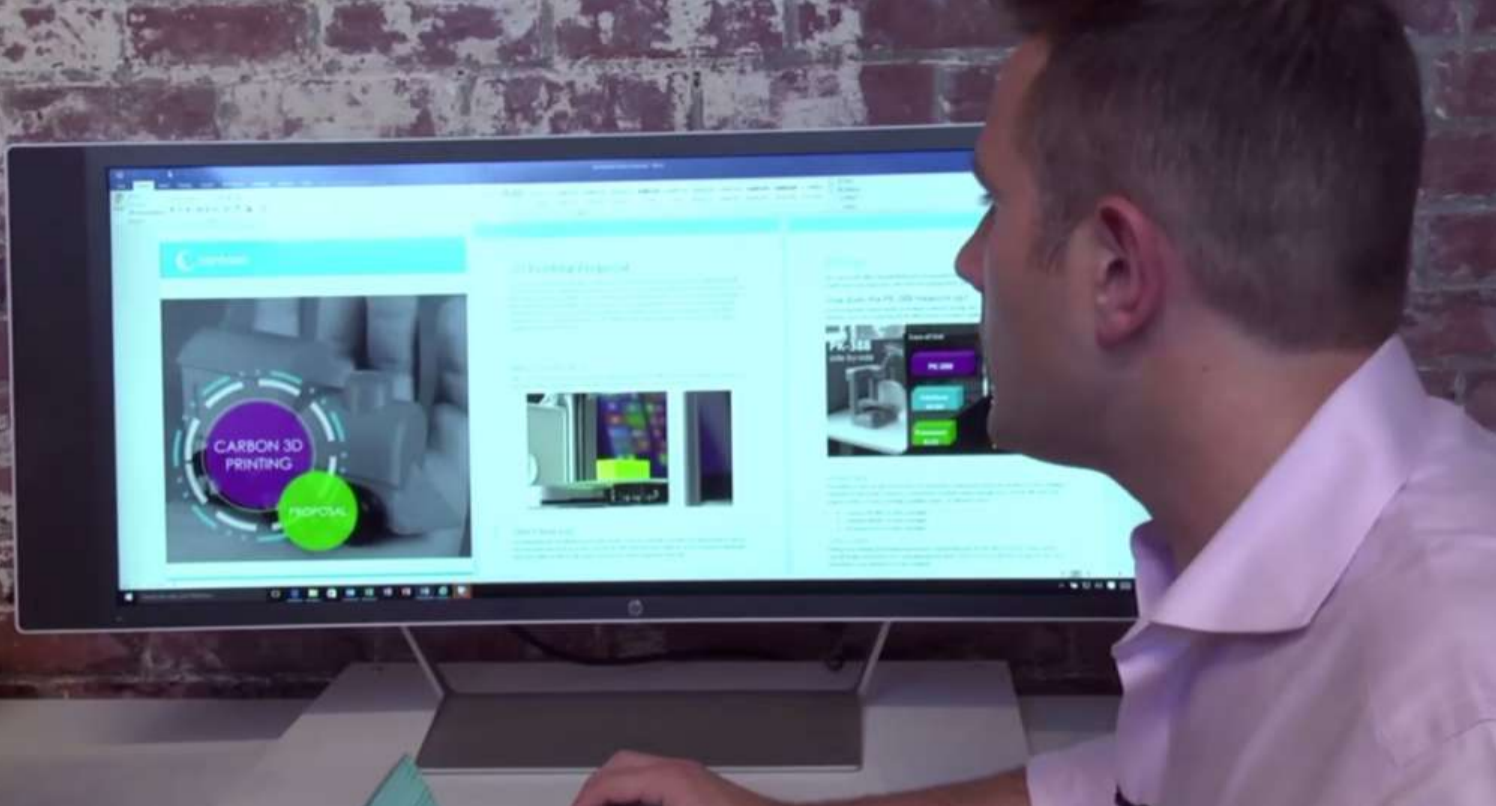

WHAT'S NEW
Alex Bradley, who's on the Office 2016 team at Microsoft, went one-on-one with *PC Magazine* to show us some of the release's exciting new features.

THE OLD AND THE NEW

There's always something old and something new in every latest Office release. Office 2016 still includes Microsoft Publisher, the page-layout app that used to be widely used for preparing menus and posters. And there's also the Access database app for those who like to build custom data-driven applications, though it hasn't been updated since Office 2013.

A new member of the Office family is a cloud-based presentation app called Sway, which is free to download even if you don't have the rest of Office. Sway creates presentations that you read by scrolling through it in a Web browser (it's most at home in Windows 10's new Edge), pausing to click on slideshows or similarly animated or expandable features. Your Sways are housed on Microsoft's servers, so you probably won't want to use them for sensitive data.

Throughout Office 2016, you'll find geological layers of features that haven't been improved in years because too few people use them. Word's Master Documents is a potentially powerful feature that lets you edit chapters as separate files, yet also combine them in a master document that imports the separate chapters when you open it and exports them again when you close it. This feature is dauntingly complicated, and produces files that tend to get corrupted, so Office veterans generally suggest you shouldn't use it. An improved and updated version would be right at home with Microsoft's new collaboration features, however, and maybe Microsoft will give it another look in the future.

Another crucial change brings the traditional Office apps more closely in line with new mobile versions for iOS and Android. Office 2016 is now the first more-or-less universal office application suite, with consistent versions available via any modern Web browser and every standard desktop and mobile platform except Linux.

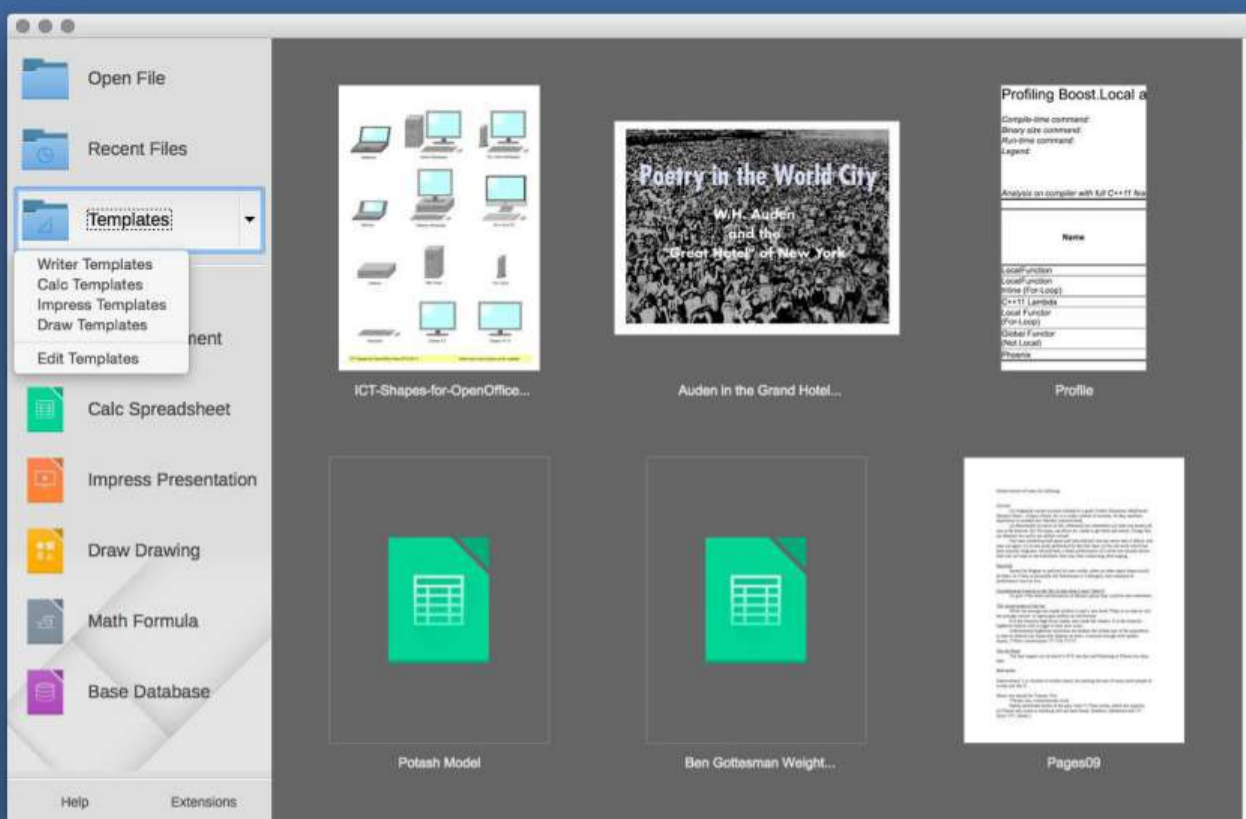

“
**For anyone
 with real
 work to do,
 it’s almost
 impossible to
 imagine living
 without
 Microsoft
 Office.**
 ”

OFFICE ALTERNATIVES

Although Office 2016 as a whole towers over its competition, it isn’t the best at everything. LibreOffice 5 is a free and open-source suite, so governments and security-conscious organizations can use it without worrying about what might be hidden in Microsoft’s code—but it’s also clumsy and unstable. Google Apps has Google’s characteristic smooth interface, but less overall power and flexibility, and it lacks the speed and convenience of desktop-based apps. Corel’s WordPerfect Office can’t match Word in power, but easily outclasses it in some special-purpose features, such as its handling of multi-chapter documents and its precise control over formatting or cleaning up documents created by OCR software. Apple’s former iWork suite (Pages, Numbers, and Keynote) is spectacularly beautiful to look at, and Keynote produces slightly more impressive presentations than even PowerPoint, but these apps exist only on Apple’s platform, whereas Microsoft Office 2016 for the Mac far surpasses them in power and cross-platform compatibility.

Everyone gets annoyed at the suite sometimes, but for anyone with real work to do, it’s almost impossible to imagine living without Microsoft Office. The 2016 version is, all in all, a spectacular achievement and our no-contest Editors’ Choice.

EDWARD MENDELSON

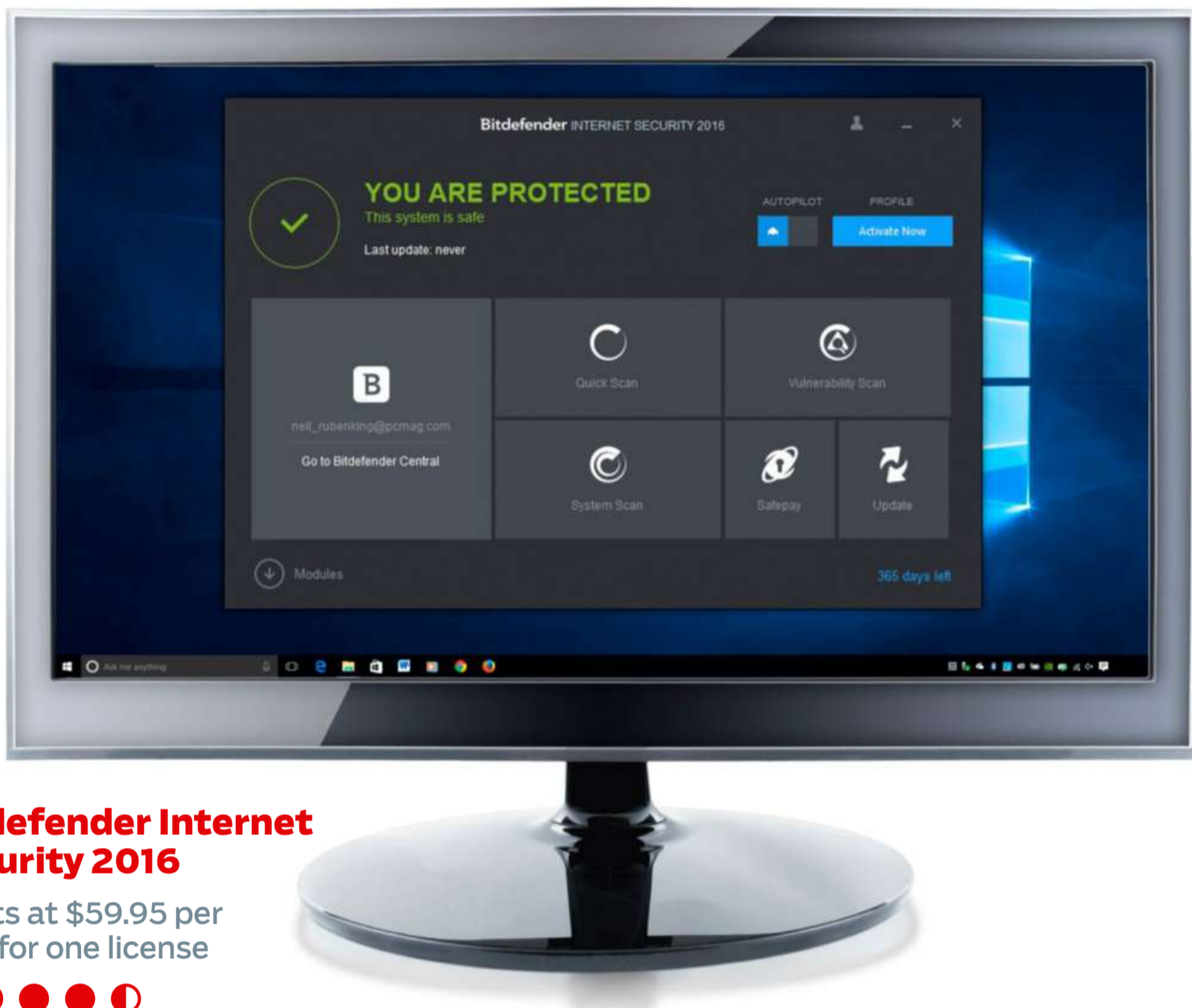

Bitdefender Internet Security 2016

Starts at \$59.95 per year for one license



Security Software That's Powerful, Unobtrusive



When you install a security suite, you expect it to keep your PC or devices safe and stay out of your way. Bitdefender Internet Security 2016 packs a ton of protective features, but if you leave it in its default Autopilot mode, you'll hardly know it's there. And the protection it offers is excellent.

THE BASICS

The product's main window hasn't changed a lot since last year. It's still dark gray, with big panels representing important tasks like scanning for malware or vulnerabilities. The biggest panel takes you to Bitdefender Central online, where it's extremely simple to extend protection to as many other PCs as you have

software licenses for. Clicking the Modules link at the bottom of the main window slides a new page into view, with access to all of the suite's functions organized into Protection, Privacy, and Tools categories. (A few grayed-out components here become available in Bitdefender's Total Security mega-suite.)

You can buy Bitdefender Internet Security as a single product for \$59.95 per year or a three-pack for \$79.95, but your options don't stop there. You can get a five-license subscription for \$119.95, or a ten-pack for \$209.95. But Bitdefender's Family Pack plan, already available for Bitdefender Total Security, is coming to the entry-level suite as well. When it does, you'll be able to cover all of your family's PCs, Macs, and Android devices for \$109.95 per year. (It's worth pointing out that a set of unlimited licenses for a household is now the default for the entire McAfee product line. Perhaps this is the wave of the future?)

PROTECTION PERFECTION

Bitdefender doesn't participate in testing with West Coast Labs or ICSA Labs, but every test that includes the company's technology rates it top-notch. Of the last 12 tests by Virus Bulletin, for example, Bitdefender received VB100 certification in every single one.

AV-Test Institute rates antivirus programs on protection, performance, and usability, assigning up to six points in each category. Bitdefender earned a perfect 18 points in this three-part test. AV-Comparatives performs a wide variety of tests, five of which I follow closely. Bitdefender rated Advanced+, the highest rating, in all five. Kaspersky Internet Security is the only suite whose test scores beat Bitdefender's. Even so, that's only because Bitdefender isn't included in testing by Dennis Technology Labs; Kaspersky earned the top rating from it.

Bitdefender also earned excellent scores in my own hands-on malware-blocking tests. With 93 percent

Bitdefender Internet Security 2016

PROS Excellent range of security tools. Powerful antivirus, spam protection. Firewall is tough, unobtrusive. Tiny performance impact.

CONS Parental controls currently uneven. Some inaccuracy in password manager's form-filling.

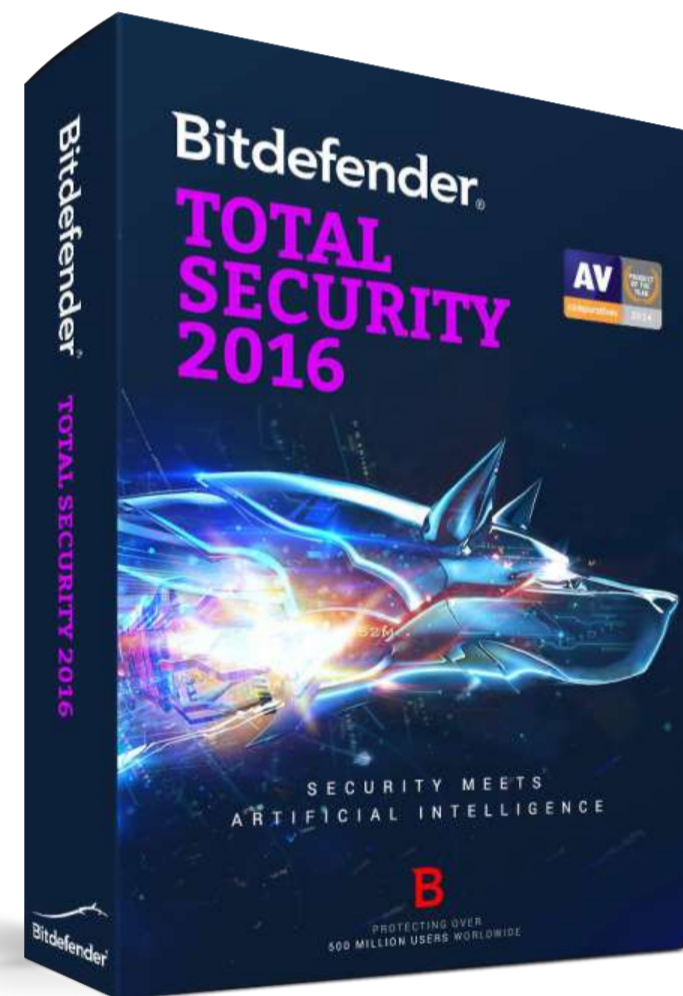

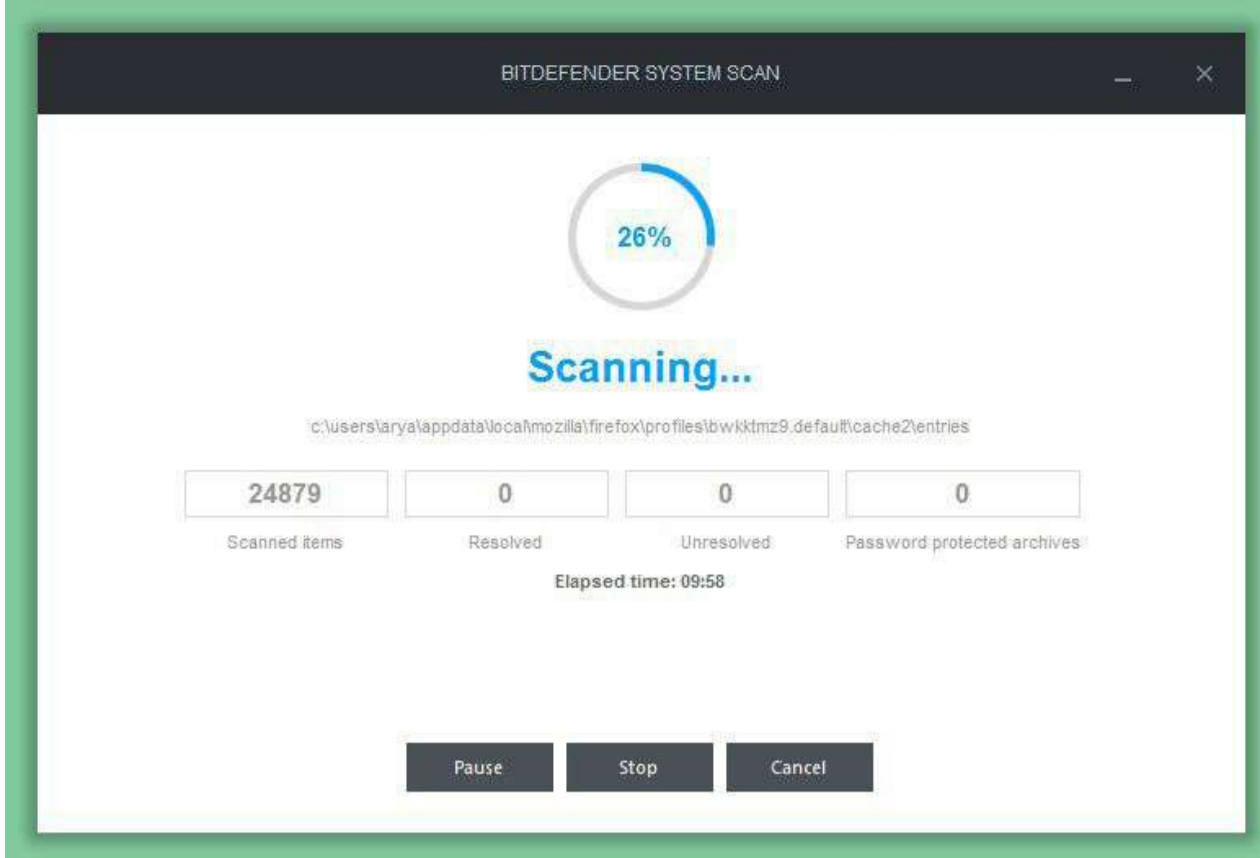

“
**Only
Bitdefender
has an
antiphishing
detection
rate even
better than
Norton’s.**
”

detection and 9.3 of 10 possible points, it beat all other products tested using the same malware collection. Challenged with 100 extremely new malware-hosting URLs, Bitdefender blocked 74 percent, almost twice the average for current products. With 91 percent protection, McAfee holds the top score in that test.

My antiphishing test compares each product’s phishing detection rate with that of Symantec Norton Security and with the protection built into Internet Explorer, Chrome, and Firefox. Only a handful of current products can even manage a detection rate that beats all three browsers. Only Bitdefender has an antiphishing detection rate even better than Norton’s.

TOP-NOTCH SPAM FILTER

Bitdefender’s spam filter integrates with Microsoft Outlook, Outlook Express or Windows Mail, and Thunderbird to automatically divert spam messages to their own folder. From its toolbar you can mark messages as spam or not spam, if they were misfiled initially. You can also whitelist or blacklist any sender. Those using a different client will need to create a message rule to divert the spam.

Some spam filters include elaborate multipage configuration dialogs that let you set thresholds, turn on or off various detection components, and so on. Not

Bitdefender. There are just two settings, checkboxes that tell it to block messages written primarily in Asian or Cyrillic characters. By default, only Asian-character messages get blocked.

As part of my testing, I measure the average time needed to download 1,000 messages, comparing that with the time recorded using no spam filter.

Bitdefender didn't cause any appreciable slowdown in the download process. I then discarded old e-mails and sorted the rest (into valid personal mail, valid bulk mail, and undeniable spam) in both the Inbox and Spam folder.

Bitdefender outperformed every other suite I've tested in this way, and even managed to unseat Cloudmark DesktopOne Basic 1.2, one of our two Editors' Choice standalone spam filters. Bitdefender only misfiled one valid email, a message from me about malware, and it kept 98.2 percent of undeniable spam out of the Inbox.

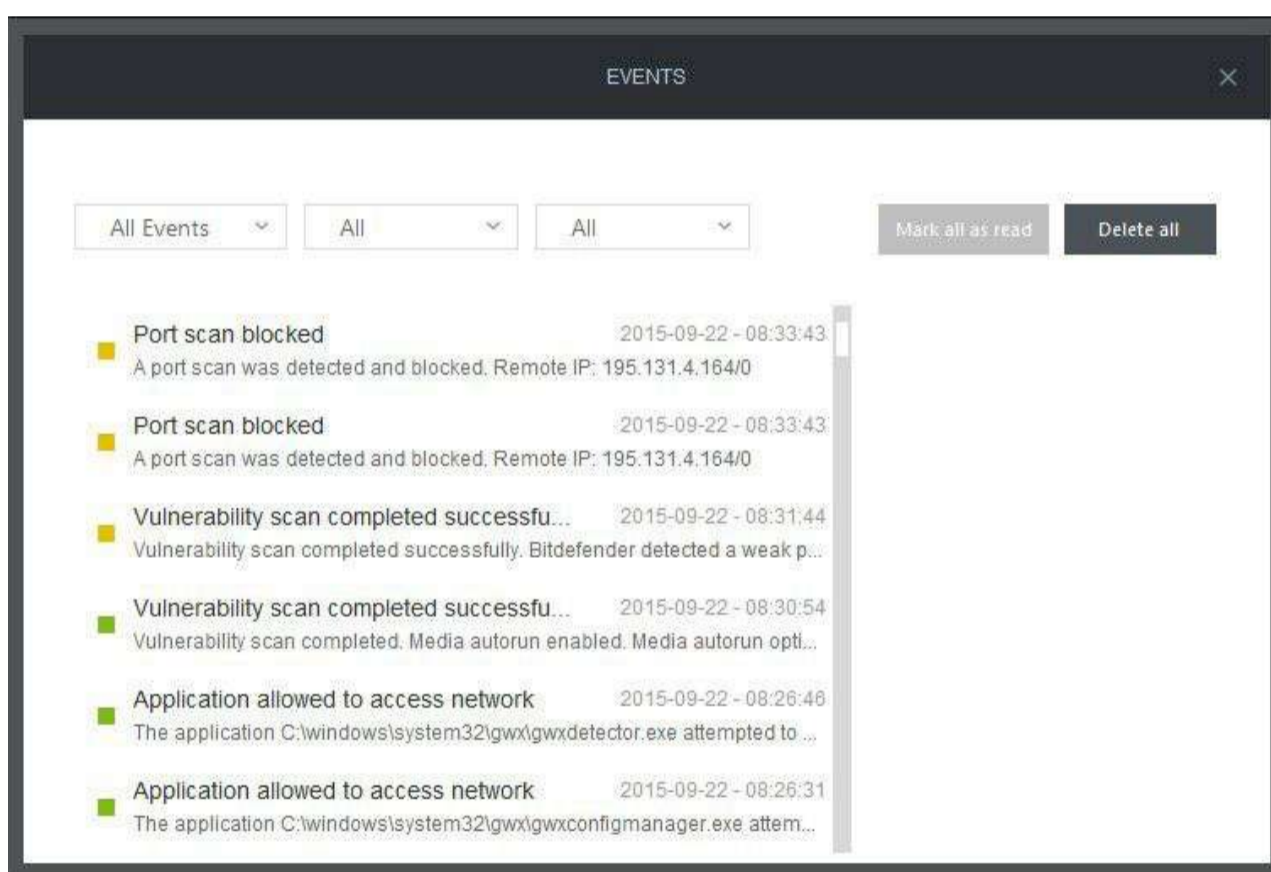

**NOT QUITE ANY
PORT IN A STORM**
Bitdefender Internet
Security 2016's
firewall quietly
blocked all port
scans and other
Web-based tests we
threw at it.

TOUGH, UNOBTRUSIVE FIREWALL

In its no-hassle Autopilot mode, Bitdefender does its best to take care of business without bothering you. The firewall is no exception; you won't see flocks of confusing pop-ups flying across your screen. The firewall does keep track of programs that access the Internet and bans certain dangerous connection types. It doesn't, however, ask you to decide what network permissions an unknown program should receive; instead, it grants access and keeps an eye on the unknown program's behavior.

When I hit it with a port-scan attack, Bitdefender logged the attack and put all the system's ports in stealth mode. It passed all of my other Web-based tests as

well. In fact, it put a total block on one test domain. That sort of block lasts until you reboot, which is what I had to do in order to finish the test.

I couldn't terminate any of Bitdefender's modest four processes, and my attempts to disable its two services just returned "Access denied." This is a tough firewall!

“
**This is
a tough
firewall!**
”

INTRUSION DETECTION

Separate from the firewall, Bitdefender offers an Intrusion Detection system with three levels of protection. Even in the default Permissive level, it fends off malware drivers and protects Bitdefender files against alteration.

The Medium protection level prevents attacks that inject malicious DLLs into legitimate programs. If you turn it all the way to Aggressive, it warns about a variety of possible problems including Internet Explorer leaks and attempts to change your home page. So, why not just run at Aggressive level? Because the two higher levels generate more pop-up alerts.

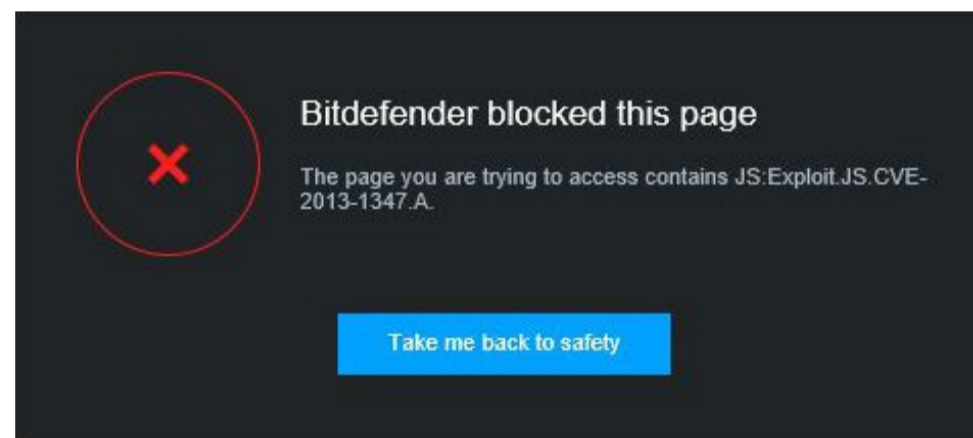

I thought perhaps Intrusion Detection would fend off exploit attacks, but my Bitdefender contacts explained that's not what it's for. Indeed, when I attacked the test system using exploits generated by the Core Impact penetration tool, I didn't see any reaction from Intrusion Detection. None of the exploits succeeded, and Bitdefender actively identified and blocked about a third of them.

OTHER FEATURES

In addition to staying out of your way, Autopilot mode does its best to configure the antivirus component for the way you're using your computer. If you're working hard, playing games, or watching a movie, it adjusts so as to do its job without getting in the way.

Some ransomware attacks encrypt your essential files and then demand you pay them for the decryption key. Bitdefender's Ransomware protection simply prevents all unknown programs from changing any files in specified folders (by default, every user's Pictures and Documents folders).

Bitdefender Wallet is a simple password manager that also fills out Web forms with identity and credit card data. It handles all the basic functions, but doesn't compare with the best standalone password managers. When you do log into a financial site, Bitdefender offers to open it in the isolated SafePay desktop and browser to prevent interference by any nasty process that might have gotten past the antivirus. Naturally, Wallet works within the SafePay browser.

Many security products offer a vulnerability scan that looks for missing security patches in your operating system, browser, and popular programs. Bitdefender's vulnerability scan also checks for weak Windows account passwords and a few other security lapses.

For the record, a handful of features found in last year's edition have vanished. These include the Safego Facebook privacy app, a tool to prevent transmission of too-personal data, and a collection of tune-up tools.

You'll want to enable Rescue Mode when your computer is healthy and happy. If ransomware or persistent malware makes booting into Windows impossible, you can instead boot into the non-Windows Rescue Mode to root out the problem and get your system working again.

The Parental Advisor module gives you a lot of control over your children's computer use, letting you block websites, manage the applications they use, follow their activity on Facebook, and even guard their phone usage on Android devices (you can block calls and texts and define safe or restricted usage areas). In my testing, not all of these features worked exactly as they were supposed to, but my Bitdefender contact suggested these problems would be addressed in the near future.

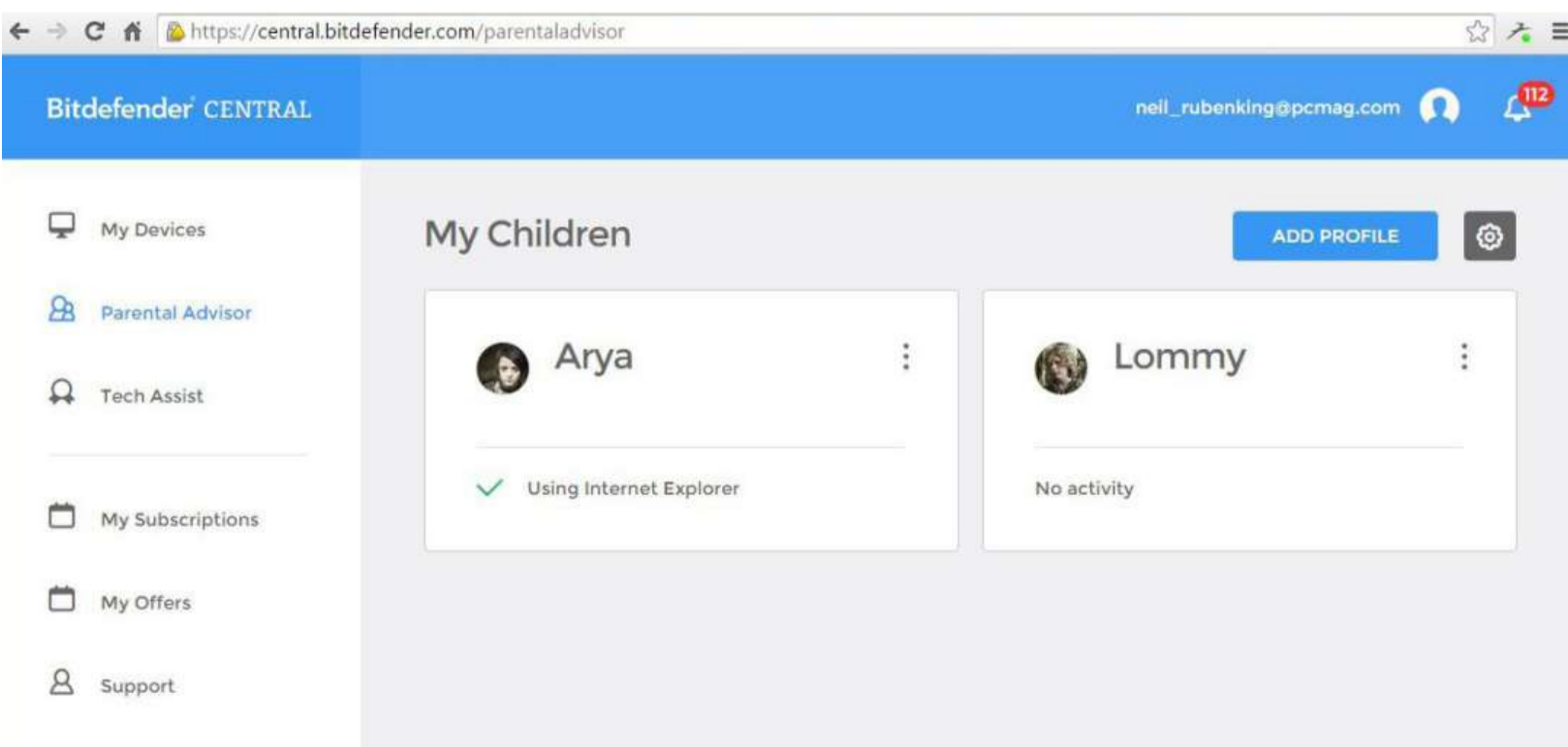

PARENTAL ADVISOR
In the online Bitdefender Central Console you can create entries for your children, identify which devices they use, and configure settings



Dashboard

Activities

Interests

Friends

Places

Social

E-MAIL

High threat to privacy

Having email public can attract spam. Set it to be visible only to your child.

RELATIONSHIP

High threat to privacy

Married

Relationship should not be visible by public.

BIRTHDAY

High threat to privacy

This is a key information in identifying your child and it should be visible only to your child.

RELIGION

Pastafarian

Possible privacy threat

This information may be sensitive, depending on what your child has posted. It should be visible only by friends.

FACEBOOK REPORT

When you install the Bitdefender app on your child's Facebook account, it generates a report of privacy threats. You can also view the pages your child has liked and recent photos.

LOW PERFORMANCE IMPACT

Although it requires about 1.5GB of storage space, Bitdefender is a nimble package in operation. I found no system slowdown at all after installing the software, and my standard performance tests of copying a large collection of files between drives and repeatedly zipping and unzipping the same file collection took just marginally longer (8 percent and 3 percent, respectively). Very few modern suites put any significant drain on system performance, but Bitdefender is among the best in this area. (F-Secure Internet Security 2015 is just as fast, though AVG Internet Security 2015, which averaged just 1 percent across my tests, is fastest.)

A SWEET SUITE

Bitdefender Internet Security 2016 has everything you'd want in a security suite—and more. Its antivirus component gets stellar scores in both lab tests and our in-house trials, and its antispam tool beat out all competitors for accuracy. The firewall doesn't attempt fancy exploit blocking, but it's tough and hassle-free. Add features like ransomware protection, password management, and secure browsing, and you have a suite with power to spare.

NEIL J. RUBENKING

Features

**THE MANY
DIMENSIONS OF
3D PRINTING**

**THE YEAR OF
MAGICAL PRINTING**

**THE KING OF
3D PRINTERS**

FEATURES

THE MANY DIMENSIONS OF 3D PRINTING

If you've ever dreamed of being able to manufacture anything, on short notice and from the comfort of your home, 3D printing is about to make that—and much more—a reality. Here's everything you need to know about this dazzling technology that's already changing everything.

BY TONY HOFFMAN

They're not your granddad's daisy wheel printer, or your mom's dot matrix. In fact, they bear little resemblance to today's document or photo printers, which can only print in boring old two dimensions. As their name suggests, 3D printers can build objects from scratch out of a variety of materials. They're going mainstream, showing up at retailers such as Staples, Best Buy, and Home Depot, and you can buy numerous 3D printers and their supplies on Amazon.com and through other online outlets. Though still mostly found on shop floors or in design studios, in schools and community centers, and in the hands of hobbyists, it won't be long before 3D printers are found on workbenches, in rec rooms, and even in the kitchens of homes near you—if not your own.

WHAT IS 3D PRINTING?

At its most basic, 3D printing is a manufacturing process in which material is laid down, layer by layer, to form a three-dimensional object. (This is deemed an additive process because the object is built from scratch, as opposed to subtractive processes in which material is cut, drilled, milled, or machined off.) Although 3D printers employ a variety of materials (such as plastic, metal, or other) and techniques (see “How Does 3D Printing Work?” below), they share the ability to turn digital files containing three-dimensional data—whether created on a CAD (computer-aided design) or CAM (computer-aided manufacturing) program or from a 3D scanner—into physical objects.

IS 3D PRINTING EVEN PRINTING?

Yes, 3D printing can be considered printing—although not as it's traditionally been defined. The relevant Webster's definitions for printing center around production of printed matter, publications, or photographs, and producing by means of impression (the application of pressure). The first doesn't fit—

NOTHING BUT OPTIONS

Filament for 3D printers comes in a wide variety of colors and materials so you can print objects that look however you desire.



unless the definition is expanded to include the fabrication of 3D objects, created from scratch rather than being printed on—and most 3D printing techniques don't involve impression.

From a technological perspective, 3D printing is an outgrowth of traditional printing, in which a layer of material (usually ink) is applied. Usually it's so thin that there is no noticeable height (though with solid ink printers, it is somewhat thicker). What 3D printing does is greatly extend that height through the application of multiple layers, so it would make sense to expand the definition of printing to include the fabrication of three-dimensional objects in this manner.

HOW DOES 3D PRINTING WORK?

Much like traditional printers, 3D printers use a variety of technologies. The most commonly known is fused deposition modeling (FDM), also known as fused filament fabrication (FFF). In it, acrylonitrile butadiene styrene (ABS), polylactic acid (PLA), or another thermoplastic is melted and deposited through a heated extrusion nozzle in layers. The first 3D printers to come to market, made in the mid 1990s by Stratasys with help from IBM, used FDM—a term trademarked by Stratasys—as do most 3D printers geared to consumers, hobbyists, and schools.

In stereolithography, a UV laser is shined into a vat of ultraviolet-sensitive photopolymer, tracing the object to be created on its surface. The polymer solidifies wherever the beam touches it, and the beam “prints” the object layer by layer per the instructions in the CAD or CAM file it's working from.



From a technological perspective, 3D printing is an outgrowth of traditional printing.

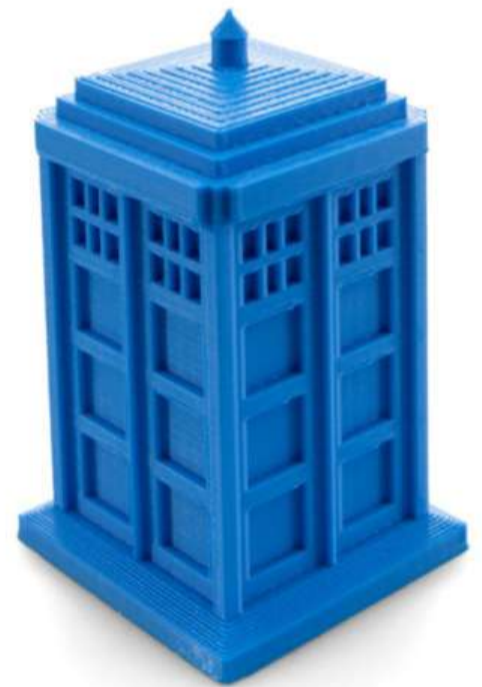

DO THE RIGHT THINGIVERSE

Designs for 3D printing fun toys, like this Yoda head and TARDIS, as well as practical items can be downloaded from online libraries like MakerBot's Thingiverse.

DLP (digital light projector) 3D printing exposes a liquid polymer to light from a digital light processing projector, which hardens the polymer layer by layer until the object is built and the remaining liquid polymer is drained off.

Multi-jet modeling is an inkjet-like 3D printing system that sprays a colored, glue-like binder onto successive layers of powder where the object is to be formed. This is among the fastest methods, and one of the few that supports multicolor printing.

It's possible to modify a standard inkjet to print with materials other than ink. Enterprising do-it-yourselfers have built or modded print heads, generally piezoelectric heads, to work with various materials—in some cases printing out the print heads themselves on other 3D printers! Companies like MicroFab Technologies (microfab.com) sell 3D-capable print heads (as well as complete printing systems).



Selective laser sintering (SLS) uses a high-powered laser to fuse particles of plastic, metal, ceramic, or glass. At the end of the job, the remaining material is recycled. Electron beam melting (EBM) uses—you guessed it—an electron beam to melt metal powder, layer by layer. Titanium is often used with EBM to synthesize medical implants as well as aircraft parts.

Depending on the technique, 3D printers can use a variety of materials, including but not limited to metals (stainless steel, solder, aluminum, and titanium among them); plastics and polymers (including composites that combine plastics with metals, wood, and other materials); ceramics; plaster; glass; and even foodstuffs like cheese, icing, and chocolate!

WHO INVENTED 3D PRINTING?

The first 3D printer, which used the stereolithography technique, was created by Charles W. Hull in the mid 1980s. Stereolithography is largely an expensive commercial technique, with machines often costing \$100,000 or more. In 1986, Hull founded 3D Systems, a company that today sells 3D printers that use a variety of technologies and range from entry-level kits to advanced commercial systems, as well as providing on-demand parts services, mostly to business users.

WHAT ARE THE BENEFITS OF 3D PRINTING?

With 3D printing, designers have the ability to quickly turn concepts into 3D models or prototypes (aka rapid prototyping), and implement rapid design changes. It lets manufacturers produce products on demand rather than in large runs, improving inventory management and reducing warehouse space. People in remote locations can fabricate objects that would otherwise be inaccessible to them. From a practical standpoint, 3D printing can save money and material over subtractive techniques, as very little raw material is wasted. And it promises to change the nature of manufacturing, eventually letting consumers download files for printing even complex 3D objects—including, for example, electronics devices—in their own homes.



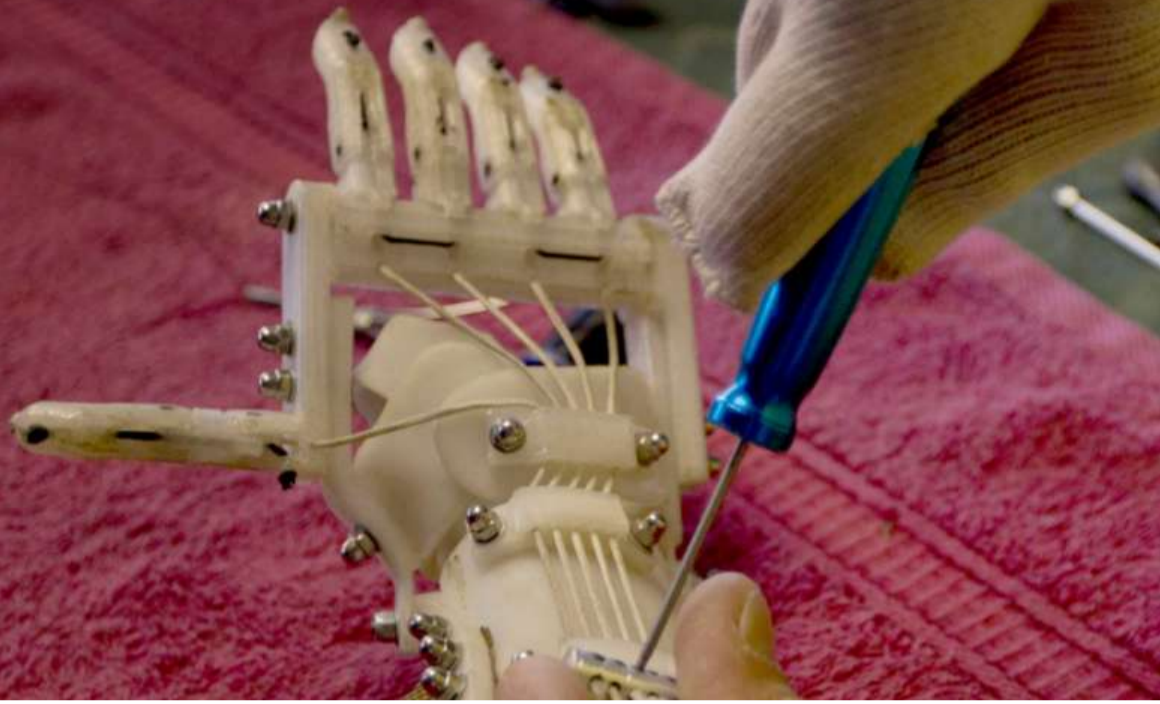

OUT ON A LIMB
Prosthetics are among the most important current practical uses for 3D printing, helping restore limbs that were lost during accidents or violence, or were missing from birth.

WHAT CAN 3D PRINTERS MAKE?

Designers use 3D printers to quickly create product models and prototypes, but they're increasingly being used to make final products as well. Among the items made with 3D printers are shoe designs, furniture, wax castings for making jewelry, tools, tripods, gift and novelty items, and toys. The automotive and aviation industries use 3D printers to make parts. Artists can create sculptures, and architects can fabricate models of their projects. Archaeologists are using 3D printers to reconstruct models of fragile artifacts, including some of the antiquities that in recent years have been destroyed by ISIS. Likewise, paleontologists and their students can duplicate dinosaur skeletons and other fossils.

Physicians and medical technicians can use 3D printing to make prosthetics, hearing aids, artificial teeth, and bone grafts, as well as replicate models of organs, tumors, and other internal bodily structures from CT scans in preparation for surgery. A good example is Project Daniel, which 3D prints prosthetic arms and hands for victims of the violence in Sudan. Also, 3D printers are being developed that can lay down layers of cells to create

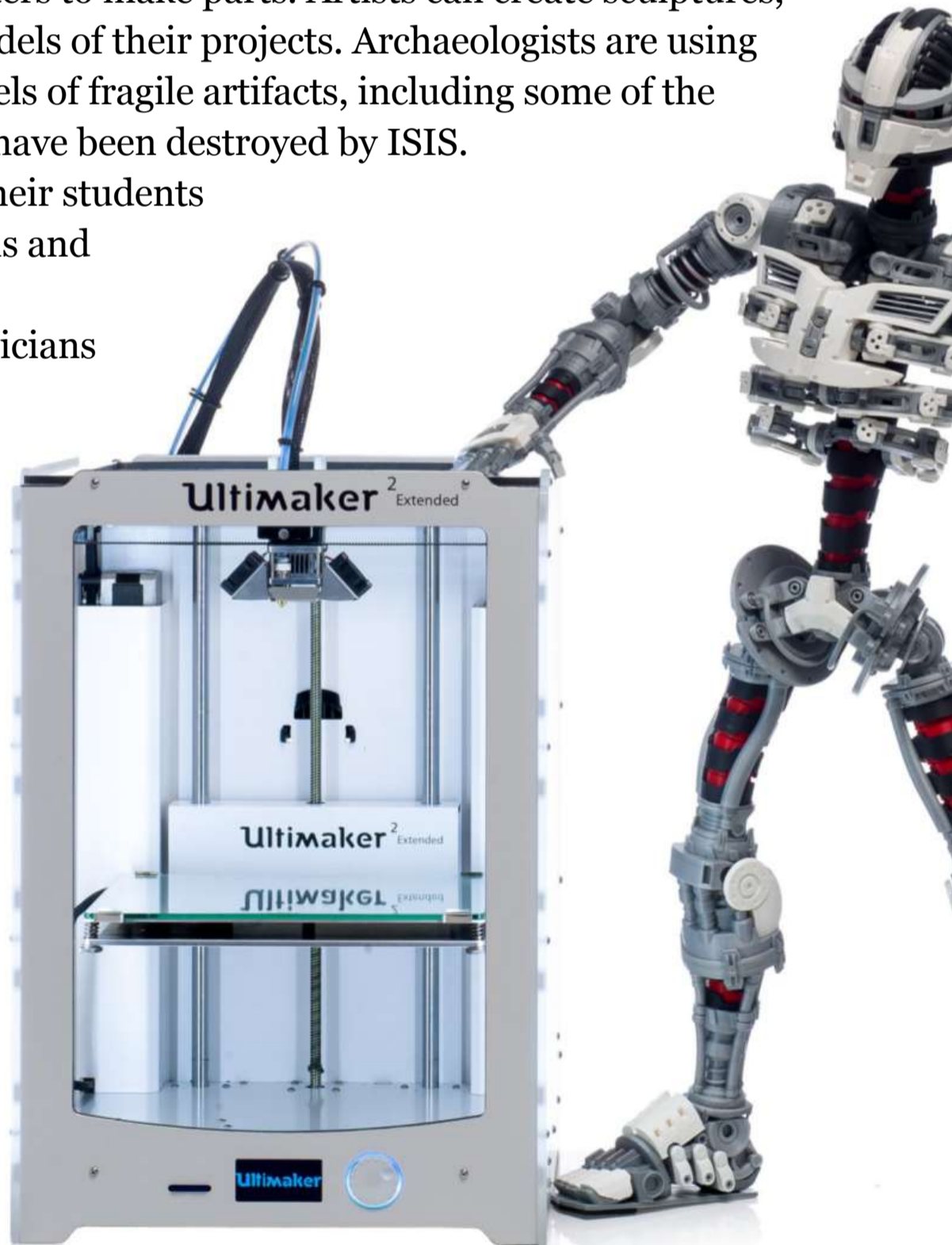

artificial organs (such as kidneys and blood vessels) are already in the R&D phase. There's even a place for 3D printing in forensics, for example to replicate a bullet lodged inside a victim (human or otherwise).

Printed electronics is a set of printing methods that enable electronic devices or circuitry to be printed on flexible material such as labels, fabrics, and cardboard, by application of electronic or optical inks. It provides very low-cost fabrication of low-performance devices. Printed electronics is beginning to be combined with 3D printing, allowing for the printing of layered circuitry or devices. A natural outgrowth of this potent combo is that someday you may be able to print out gadgets from 3D plans rather than buying them.

Food preparation is another way 3D printers can be used, to apply items in liquid or paste form such as cheese, icing, and chocolate. The French Culinary Institute has been using a Fab@Home open-source 3D printer developed at Cornell University to prepare artistic delicacies, and MIT has created a 3D food printer called the Cornucopia. NASA's 3D printing research has included food printing, such as 3D-printed pizza.

Several manufacturers have announced or released 3D food printers. The company 3D Systems, which has opened up a 3D printing culinary lab, is introducing the ChefJet and ChefJet Pro. XYZprinting is due to get into the market soon with at least one food printer, and Natural Machines is gearing up to release its Foodini.

WHAT ARE 3D PRINTING SERVICES?

You don't have to own a 3D printer to benefit from one. Many 3D printing services, such as Shapeways and Sculpteo, print gifts and other small items on order on their own 3D printers, then ship them to the customer. Customers can either submit their own 3D object files or choose items, most of them designed by other users of the service, from an online catalog.

THIRD-PARTY 3D PRINTING

Don't have a 3D printer of your own? Don't worry about it. Services such as Shapeways and Sculpteo will print objects you select and ship them to you.



But 3D printing services are no longer solely the domain of specialists. Recently, Staples introduced 3D printing services, both online and in a select group of stores, and UPS now offers 3D printing services in some of its locations.

WHERE CAN I GET A 3D PRINTER?

Most 3D printer manufacturers sell their products directly online. Many e-tailers now stock them, including online-only companies such as Amazon.com, and others that also have brick-and-mortar stores. Some of the latter, such as Walmart, Best Buy, and Staples, offer them in stores as well as online, but be sure to check for store availability on their websites as not all outlets carry them. Several 3D printer stores have opened in major cities. For instance, iMakr has storefronts in London and New York City.

A few online retailers specialize in 3D printers, such as Dynamism, which sells a range of 3D printers from different brands and also provides customer support.

WHAT SOFTWARE DO I NEED FOR 3D PRINTING?

Nearly all 3D printers accept files in what's called STL format (named for stereolithography). These types of files can be produced by most any CAD software, from expensive commercial packages like AutoCAD to free or open-source products such as Google SketchUp and Blender. For those not inclined to make their own 3D



PRINT OF SALE
Most 3D printers, such as this MakerBot Replicator Mini, may be bought at online stores or in major retail outlets such as Walmart or Staples.

files, 3D object databases such as MakerBot's Thingiverse offer numerous 3D object files that can be downloaded and printed out.

Most 3D printers come with a software suite, either supplied on disk or available for download, which includes everything you need to get printing. The suites typically provide a program for controlling the printer and a slicer, which in preparation for printing, formats the object file into layers based on the selected resolution and other factors. Some suites include a program to "heal" the object file by correcting problems that could interfere with smooth printing. The programs came out of the RepRap open source movement out of which hobbyist 3D printing developed. With some printers, you can choose the individual component programs to download rather than going with whatever is provided in the suite.

WHAT DOES THE FUTURE HOLD FOR 3D PRINTING?

Commercial 3D printers are already readily available—*PC Magazine* has reviewed a number of them—but are still rare. Expect that to change within the next few years, when they will become commonplace in houses—to be found on workbenches, in studios, home offices, and even in the kitchen. You may not find them in every household, but they'll become indispensable to those people who do have them. For the most part, items made with 3D printers have had solid, homogenous interiors, but we'll start to see more complex creations combining multiple materials and composites, and eventually printable electronics. With today's 3D printers, if you lose your TV remote's battery cover you can print a replacement cover. With tomorrow's, if you lose your remote, you'll be able to print a new remote.

As you might expect, 3D printing is gaining a foothold in outer space. NASA is experimenting with 3D printers on board the International Space Station. Eventually, 3D printers could be used to create habitats on Mars and other





ROBOHAND

South African woodworker Richard Van As and Seattle prop designer Ivan Owen have collaborated on Robohand, a mechanical hand that can be 3D printed on MakerBot hardware.

Image courtesy of MakerBot

worlds. To save the Apollo 13 astronauts from dying of carbon monoxide asphyxiation, NASA had to find a way to in effect fit a square peg into a round hole. Had there been a 3D printer on board, they may have been able to easily solve the problem by designing a connector and printing out what was needed.

Astronauts can't take a swing by Home Depot if they need to replace a valve or widget, but a 3D printer could fabricate one as needed. Likewise, we'll see 3D printers in Antarctic bases and other remote Earthly locations, where folks can't wait six months for the next resupply to replace essential parts or tools.

Medical applications of 3D printing don't stop with prosthetics, hearing aids, and dental crowns. (See "What Can 3D Printers Make?" above for a preview of what's in the works.) Replacement parts needn't be restricted to the mechanical.

Although 3D printing is still in its infancy, we're seeing an explosion in the variety and uses of these devices. It's similar to where personal computing was in the late 1970s. Though it's easy enough to see some of the areas the field of 3D printing will branch into, others are beyond our ability to predict, just as no one around in 1980 could have imagined much of what the personal computer would turn into. It's possible that 3D printing may not have the same impact as the PC, but it does have the potential to revolutionize manufacturing and, perhaps more important, bring it into the hands of everyday consumers. One thing's for sure, though: 3D printing is here to stay.

FEATURES



THE YEAR OF MAGICAL PRINTING

BY MICHAEL LYDICK



How can I possibly describe what it's like owning a 3D printer for a year? It's not easy. It's sort of like asking someone why they like sunsets or the opera. Instead, let me describe the ten things I learned over the last year—and what you can expect to go through yourself after you open the box of what I call “the best Christmas present ever.”

1. THE FIRST FEW HOURS ARE GLORIOUS

When you first get the printer, you believe yourself to have Tony Stark–like resources and abilities. There it was, my XYZprinting da Vinci 1.0: plugged in, the transformer of the power supply humming back at me, daring me to be the next Bill Gates or Steve Wozniak. Three hours later, my wife was in the kitchen with me, feigning her excitement over the sample “twisted vase”; the file for it came preloaded on the printer's SD card, so I printed three of those vases.

But one evening before bed, I found myself staring at the printer and realizing I had been “displaying” it in my poor wife's living room like the infamous “leg lamp” from *A Christmas Story*. (“Frah-GEE-LAY—it must be Italian!”). Karen didn't break it the way the wife in that movie did, but she let me know she wanted her view of the backyard back.

2. AFTER THE 15TH SAMPLE PRINT, IT'S TIME TO GROW UP

You can only print so many vases and Yoda heads before you become disillusioned with owning a 3D printer. You soon start to realize that whoever programs the printer's sample files optimized those files in the “G-code” (the code that tells the printer how to make each item). What about files online? Sure—there are thousands of parts files you can download from MakerBot's Thingiverse website. But you quickly realize that close to 90 percent of those files are useless electronic flotsam. (Oh no, did I waste my Christmas



MULTI-DIMENSIONAL
The author, Michael Lydick, and his 3D printer, the XYZprinting da Vinci 1.0 (aka “the best Christmas present ever”).



list wish?) I'd printed my son a Pokémon. My daughter got her My Little Pony figurine. My oldest got a batarang. My wife got a chicken and a dinosaur. Each time, the result was the same: a *"Thank you, Daddy!"* followed by 30 seconds of adoration, and then that sense of, "Okay, did you get me a real present?" You start to feel like a guy telling a joke who has to emphasize how funny the punch line is. "Why don't other people think these things are as cool as I do?"

3. THERE ARE THREE PHASES TO OWNING A 3D PRINTER

1. *The Tchotchke phase.* These are useless things that were fun to print that I could give as gifts to my kids. They go from "great!" to "yawn" in about an hour.

2. *The Utilitarian phase.* Items made from files from online libraries that would actually be used for something in our day-to-day lives. Hinge broken on our Coleman cooler? There's a file I can download and print that will fix that, and I'll look like Drew on the HGTV show *Property Brothers*—sans the perfect hair and plaid shirt.

3. *The Designer phase.* Things I would have to design from scratch, to make something that hasn't previously existed in the known physical universe.

Setting these goals for myself turned out to be bittersweet. But at various points in your ownership, you hit plateaus. You're thrilled that you were able to get the printer to do what it did, but you're always wondering, "How do I get it to do what that guy online did?"



**I'll look like
Drew on the
HGTV show
*Property
Brothers*—sans
the perfect
hair and
plaid shirt.**





4. 3D PRINTING MAKES YOU FEEL ALONE AT FIRST

There are two types of filament deposition–style 3D printers on the market now. There are expensive ones (\$2,000 and up) that can do really cool stuff, and use plastic filament you can buy anywhere. Then there are the sub-\$1,000 contenders. These printers are gateway drugs—and you soon learn that the companies that make them are more interested in selling you their proprietary filament (for a premium) than helping you make amazing things in your home. You then realize that their proprietary filament and software can’t make the coolest things online, and that you’ve bought yourself into a corner—surrounded by vases and Yoda heads. The feeling is a lot like seeing a recipe for Minion donut holes on Pinterest and then comparing the results to the picture you’d pinned.

I was very much alone with regards to the printer company. Emails would go unreturned. The manual (all ten pages of loosely translated Chinese-obvious stuff like “make sure you printer plugged into wall socket unit”) was useless. I was very much left with the feeling that as long as I was faithfully wasting hundreds of yards of lucrative subpar plastic filament, they were perfectly content to take my money. I felt the way Elaine from *Seinfeld* did in that one episode where she thought she was dating a handsome man, only to find out he was standing in the “good light.”

5. 3D PRINTING FORCES YOU TO LOOK FOR HELP

There are these things online called “forums.” (Until this experience, I’d never joined a forum in my 44 years on Earth.) Many of the 3D printing forums are filled with equally disgruntled printer owners who have even more Yoda heads

hanging around than you do. And the cheaper the initial cost of the printer, the more prolific the forums are. Usually the dialogue on these forums went something like this:

CONSUMER: I bought a 3D printer and I'm having a lot of trouble.

FORUM GURU: What kind did you get?

CONSUMER: A BRANDXXX 1.0A from Amazon.

FORUM GURU: Oh, I'm so sorry for you. (*sighs, shakes head*)

CONSUMER: Wait, why? What did I do wrong?

It hurts at first, like going to a gym and discovering that you're the only overweight person there. But soon you realize it will be okay. The forum guru pointed me to a saved list of "mods and improvements" that I had to complete before the printer would be able to print the "utilitarian" stuff or perfect renditions of those really awesome Art Deco vases (which looked like pinecones when I tried to print them). I found that many of the mods were really simple, and I loved that I could actually use the printer I bought to *make parts to fix the printer*.

Where are these parts, you ask? It turns out that there's a "dark Web" of Thingiverse full of parts people have designed to make their cheap printers not only functional, but behave like the \$2,000-plus models. There's an entire economy and community of people, not unlike the popular VR world Second Life, who are devoted entirely to upgrading and modifying printers. Mods and hacks ranging from keep-it-simple-stupid easy to how-did-they-even-think-of-that-it's-genius upgrades.

I'd like to lie and tell you this was an easy process, but it wasn't. It was an emotional time—across about two months' worth of fixing. But after spending all that time searching, printing, installing, and adjusting, I had a printer that could print anything I could find online. A rocket ship, for example, that failed the first five times I tried printed perfectly after the last hack was installed.

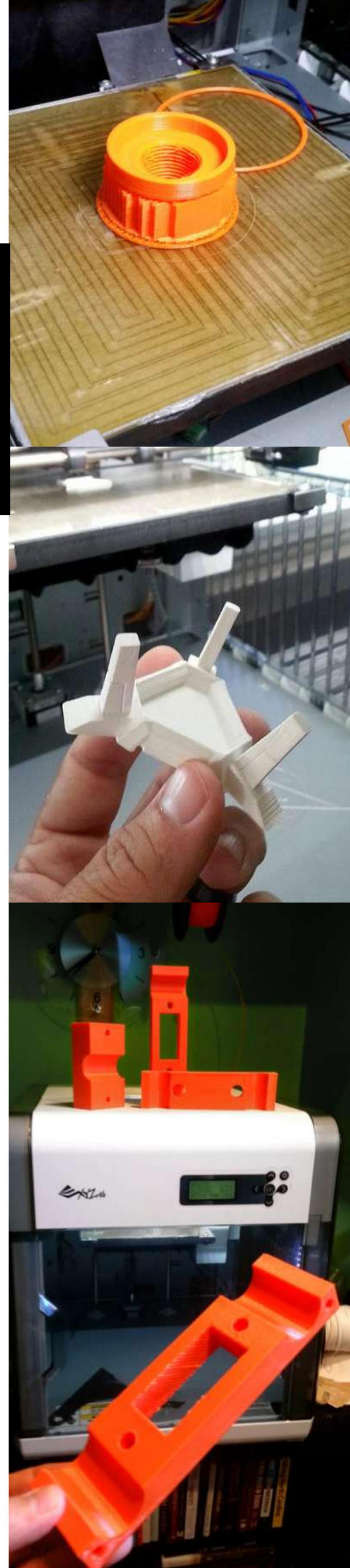



“
**Now I was
Indiana Jones
with a roll
of plastic on
the wall.**
”

6. MODS TAKE YOU FROM YAWN DAD TO SUPER DAD

I made my youngest son a velociraptor claw. Not just any claw. It was a claw that had been laser-scanned and digitized from the Museum of Natural History. I wasn't able to print it out before the upgrades, but now I was Indiana Jones with a roll of plastic on the wall.

When the extruder motor pulled back, I saw it. It was beautifully horrific and detailed. I was pretty jazzed, and got all art-class intoxicated. For effect, I took some mud from the backyard and pushed it into some of the crevasses to simulate how the claw would look right after being pulled from a dig site. To my wife's dismay, I then sharpened the very end of the claw with some fine sandpaper and handed my 10-year-old something that made his post-modern-Pokémon-PlayStation-DS mouth drop open. His reaction signaled my graduation from the “useless thing” phase: He cleared store-bought stuff off of his bedroom shelves to make room for the claw I'd printed.

I heard his two older siblings saying “Whoa, where did you get that?” as I made my way back upstairs to my office, hair unkempt, covered in dust and burnt plastic smell permeating my clothes. Music, sweet music to my ears.

7. 3D PRINTING KICKS EVERYTHING UP A NOTCH

I remember the first “phase two” things I printed after the claw. The first was a custom-designed birdhouse for my neighbor. It used old DVDs in its base to make a removable floor for cleaning, and it was pretty to look at. I made three as gifts, and each time I watched someone unwrap one, the recipients were genuinely surprised at the nice design and level of detail. They didn't believe me when I told them I had printed it in my office.

The second item was even better than the birdhouse. See, I also own a DJI Phantom quadcopter, and similar to the 3D printer, there were parts of the

copter that needed upgrading and modding if it was going to fly properly. Right up on the top of the list was a bigger battery, which in turn required a bigger battery cover (so said bigger battery wouldn't fall from the sky and kill someone—probably you).

I learned in phase two that if you can think of something you need, a nerd before you who thought the same thing has made the file for it already. So I diligently searched for and found the files on Thingiverse. I loaded them into the da Vinci software and started printing. Three hours later, I had the battery box on my copter, fitting with store-bought precision. After some very light sanding, the Phantom was up in the air flying around the field behind my house; it lasted 25 minutes this time, versus 12 to 13 minutes beforehand.

My family's attitude began changing during phase two. Instead of my bringing objects to them, expecting adoration, they'd come to me and ask "What are you doing with that piece?" and "How did you get it to do that?" Finally, the best question of all, which signaled the completion of my journey from phase two to phase three: "Daddy (Honey), can you make me something? I need it to do this." [hands me paper with drawing]

Insert Tim Taylor Grunt here: Argh argh argh!

8. 3D PRINTING IS A BIG TIME COMMITMENT

Looking back, I can't overstate the value of the useless-Yoda-head phase. A 3D printer isn't like anything you've ever used before. The closest thing I can compare it to is the first laser-printers. Remember how the paper would jam all the time? Or how you had to shimmy-shake the toner cartridge to make an error message go away? That's what it's like owning a 3D printer.

Soon after getting one, you feel like Michael Bolton from *Office Space*: When something unexpected



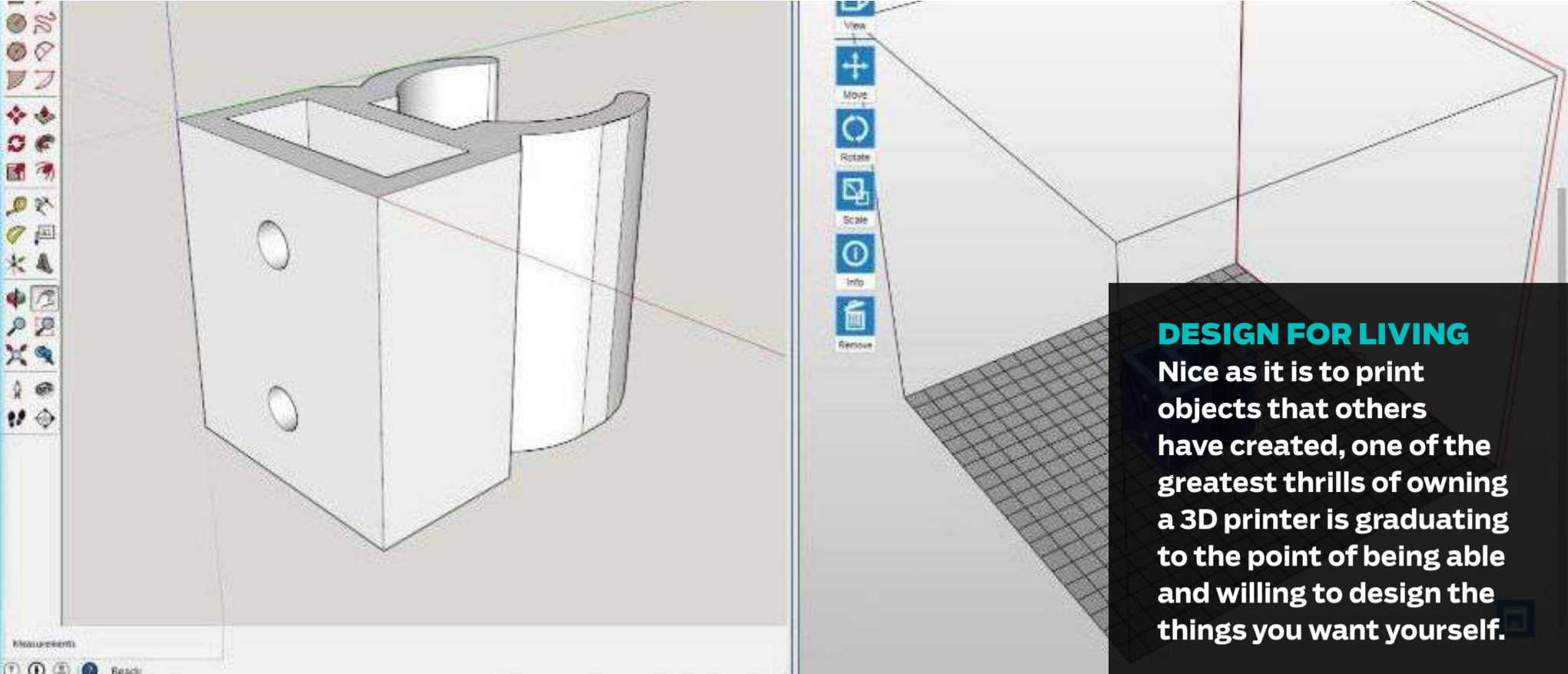

happens, you want to hit the printer with a baseball bat. But after a while you become more like Tom Hanks in *Cast Away*, confidently standing on the rock, deftly nailing fish with a metaphorical filament spear. By the eight-to-ten-month mark, you “know” your printer. You know what it can and can’t do. You know what the procedure is for “all things awful.” You think you could write the manual that would probably shorten someone’s learning curve to four weeks.

And then something truly wonderful happens: You realize you can make things no one has thought of yet.

9. 3D PRINTING IGNITES YOUR IMAGINATION

Once I’d had my printer for ten months, I started saying to myself, “You know what someone needs to make? Someone needs to make something that does XXXX.” And then you realize: *You’re that someone* and *you* can make XXXX—or even YYYY. But how to make something that doesn’t have a Thingiverse file?

There are a slew of free 3D printing design programs online: software that lets you draw the thing you want to make, and then output the file the printer needs. Autodesk makes one called Tinkercad that a child could use with a few minutes of tutorials. I used it—and still do—but ultimately I chose to work with Google SketchUp (another free program), mainly because it has a huge support community and a thousand training videos online to learn from.

So what can you make? Whatever your printer can fit in its bed. Mine has an 8-by-8-by-8-inch capacity, which is pretty big for a \$495 printer. One weekend before I went camping, I realized I needed something to get my small ham radio antenna up in the trees. Other “hams” had made “fishing reel slingshots,” by hurling lead fishing weights tied to a spool of line up over a tree. The plans online were all Rube Goldberg-y and ugly, using wires, cable ties, and tape. I

thought, “I could make something really nice,” and so I opened Google SketchUp and started drawing, using measurements off of the Walmart slingshot I’d bought for \$5.00. Not too long after, I pulled my own custom version out of the printer.

Once I got into off-road driving, I began wondering whether I could make some of the accessories I saw on everyone else’s trucks. Yes. And so I set about making a roof-rack shovel mount for my 2005 Nissan Xterra. The very next day, a man at the gas station stopped me and asked where I’d bought it. When I told him I’d 3D printed it myself, he offered me money on the spot to make him one for his truck.

I made the friend who bought me the printer in the first place a custom light bar mount for his kayak, so he could go flounder fishing at night. More people asked where we had bought it.

That same friend’s father had a boat in Myrtle Beach with a broken shower drain. It was an older piece, and no one in town had the part we needed to repair it. After getting some measurements, we were able to design a replacement piece and print it out the same day.

10. 3D PRINTING HAS THE OPPOSITE EFFECT OF MOST TECHNOLOGY

Owning a 3D printer will propel you into a community with people. Two types of communities, in fact.

There are communities of end users who will invite you to share what they’ve learned, either in person at one of the popular Maker Faires, or online via forums, Skype, or the YouTube videos they produce, often at their own expense. When you are pulling out your hair in your learning phase, plenty of people are waiting to meet you, PM you, and teach you things. People I would never have met otherwise have become good friends as a result. Moreover, you go from being the “noob” to being the “guru” pretty fast.



You advance through the ranks like a 3D printer Boy Scout, ultimately becoming an ABS Scout Leader and helping the many other people underneath you who are still learning.

The parts you make also have another effect on your life. I'm able to make things for my kids, but it requires a connection to them. I have to ask, "What do my kids really like, and what would blow them away if I printed it for them?" For example, my son has asked me to make him a Thorn gun from his Halo Xbox game. He's delirious with anticipation as I research what's out there that can be printed.

In other words, the printer requires connection to your community of family and friends to go from "leg lamp" to useful. People now know they can ask me to make things if something is broken, or if they want a Minecraft cookie cutter like the one they saw on Pinterest. I've become a "node," a local hub capable of making impossible things become possible in my office. It starts conversations that inevitably lead to "Hey, could you make me..." questions, and none of these conversations would ever have existed without the printer.

Pretty soon, these communities become bigger than you. I've just joined a global group called eNABLE, in which people print prosthetic hands for children. This is the point where you realize you're like one of those first people who had a cell phone or a website. You're one of those first kids on The Facebook. Sure, 3D printing seems like a novelty at first, but now it doesn't feel like a novelty. Any technology that has historically brought us closer together seems to flourish and last and grow exponentially. It becomes "sticky." This is happening for me, with touch points across the hall and across the world as a result.

After my first year of owning a 3D printer, I am Jack Nicholson in *As Good As It Gets*, staring at my printer and saying, "You make me want be a better man."



FEATURES



THE KING OF 3D PRINTERS

It may be pricey and noisy, but the MakerBot Replicator is worth a few sacrifices if you want the best 3D printer you can currently buy.

BY TONY HOFFMAN

The Replicator (\$2,899) is the second MakerBot printer we've tested, and it offers a much better user experience than the MakerBot Replicator 2X. The Replicator—often referred to by MakerBot and others as the fifth-generation Replicator—is free of the extruder problems we saw with the Replicator 2X, and, except for one misprint, consistently produced good-quality output in our testing. With its ease of setup and use, wealth of connectivity choices, user-friendly software, and good print quality and consistency, it brings more to the table than any other printer we've seen to date, including our previous Editors' Choice for high-end 3D printers, the Ultimaker 2.

DESIGN

The all-black Replicator is a large printer. Measuring 16.2 by 17.4 by 20.8 inches (HWD) and weighing 35 pounds, 6 ounces, it is best kept on a table or bench of its own. Its rigid frame is open at the front, on the sides, and on top, permitting quick access to the print bed and easy viewing of prints in progress. A drawback of the open frame is that the Replicator is relatively noisy for a 3D printer. Its build volume is 5.9 by 7.8 by 9.9 inches, a tad smaller overall than the Ultimaker 2's 8.1 by 8.8 by 8.8 inches.

PROS

Safe design for an open-frame printer. User-friendly software. Prints via USB, Ethernet, Wi-Fi, USB flash drives. Easy to set up, use. Very good print quality.

CONS

Can't print tall objects. Noisy during operation. Relatively expensive filament.

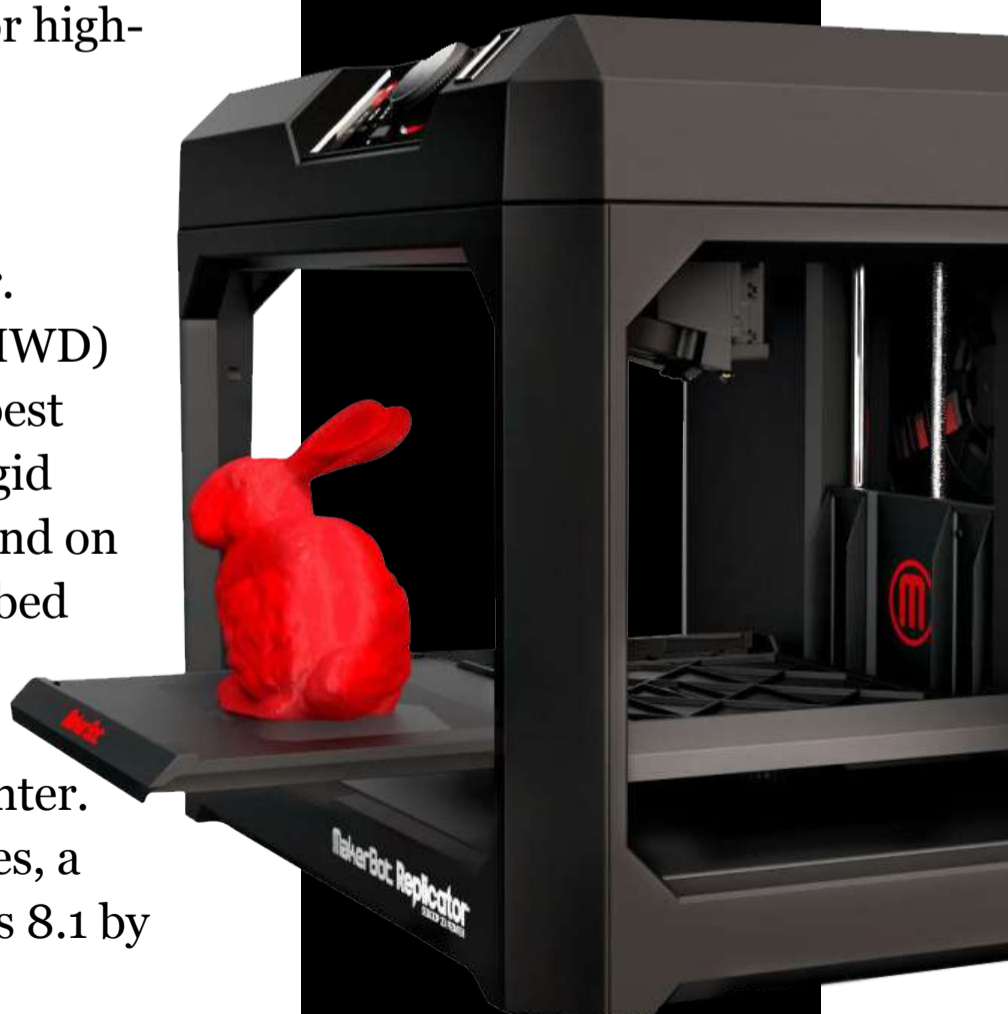



SETUP

Setting up the Replicator is a straightforward process. Once you unpack the printer, you install the Smart Extruder by pressing it against the back of the extruder carriage. Magnets lock the extruder into place. Then you lift the filament drawer in back of the printer, load a filament spool onto the spool holder, rotate the spool, snake the filament through a tube, and close the drawer. You then peel the backing off of a sheet of blue tape (several sheets are included), affix the tape to the build plate, and slide the build plate into place. You then plug in the printer and power it up.

The setup is completed with the help of the control panel, which consists of a 3.5-inch color LCD on the front of the printer, along with a dial, and two buttons to help you navigate through the menus. Your first task is to level the build plate, which is largely automatic except for one part where you have to turn a couple of knobs located below the plate until a light on the extruder assembly goes on. Leveling the Replicator's build plate is easier than with other 3D printers that require you to tighten the gap between extruder and build surface at several points until you can move a sheet of paper between the two with slight friction.

The next step—loading the filament—is a cinch. Press Load Filament on the control panel, and when the extruder is hot enough, you are instructed to insert the end of the filament into the top of the extruder. When it's in far enough, gears will grab the filament and pull it in farther.

“
**Leveling the
Replicator's
build plate is
easier than
with other
3D printers.**

”

TAKE YOUR FIL(AMENT)

MakerBot offers PLA filament in a wide variety of colors and two spool sizes for use with the Replicator, giving you lots of flexibility as to the final look of what you print out (though you're limited to only using one color at a time).



FILAMENT

The Replicator uses 1.75mm polylactic acid (PLA) filament, which MakerBot sells at \$48 for a 2-pound roll of standard filament, and \$65 for rolls of specialty (neon and translucent, for instance) PLA. This is near the high end of the price scale for PLA, though similar in price to the filament from Ultimaker, which uses a thicker (3mm) version. Although you can use filaments from brands other than MakerBot with the Replicator, the company strongly recommends against it, claiming that its filament is optimized for the printer, and that other filaments could contain impurities or otherwise compromise print quality.

If you are the sort of person who likes to experiment with multiple filament types, I have some bad news and some very good news. Currently, MakerBot only sells PLA filament for the Replicator. The good news is that it is all set to change in 2016, when the company is due to debut a line of composite filaments in which PLA is mixed with nonplastics (namely, limestone, iron, maple wood, and bronze) and can take on some of the properties of these materials.

For instance, a magnet will attract an object printed from iron filament, and you can sand and stain an object made from maple wood. When the new filament types are released, however, you will probably need to purchase a new extruder designed to work with them.



EXTRUDER

The Replicator's Smart Extruder is exceedingly easy to install or remove, as it's held in place by magnets. The printer comes with one extruder, and you can buy more from MakerBot for \$175 each. What makes the Smart Extruder smart? For one thing, it detects when you're out of filament and automatically pauses printing; without it, you would have to scrap the print if you run out of filament midway through a session. It also sends notifications to the MakerBot Desktop software and the MakerBot Mobile app. In my testing, it proved much more reliable than the two extruders in the MakerBot Replicator 2X.



CONNECTIVITY

One of the Replicator's strengths is its range of connectivity choices, the widest I've seen in any 3D printer. You can print from a computer over a USB, Ethernet, or Wi-Fi connection, as well as over Wi-Fi from an iOS or Android phone or tablet with the MakerBot Mobile app installed. You can also print files from a USB thumb drive, as long as they're saved in MakerBot's .thing file format. The USB port can be found to the right of the LCD. This is in marked contrast to the Ultimaker 2, for which connectivity is officially limited to printing from an SD card.

I installed two MakerBot print apps on my iPad Air 2: MakerBot Mobile and MakerBot PrintShop. The former is the mobile equivalent of MakerBot Desktop, and I used it to print several objects I downloaded from Thingiverse—MakerBot's repository of hundreds of thousands of user-created 3D object files. You can also use the app to see the print in progress, or take a snapshot of it, as the Replicator has an onboard camera looking down into the build area from its front-right corner.



The PrintShop app lets you create and modify objects from on-screen templates, such as a bracelet, a ring, a vase, a medal, or a block of text. A special function, Shape Maker, lets you photograph a 2D drawing with your iPad, convert it into 3D, and print it out. In my one test of PrintShop, I tweaked and printed text, namely a 3D rendering of my ham radio call sign to place in my shack, and the results were very pleasing.

SOFTWARE

The printer uses MakerBot Desktop software, which you download from the company's website. From it you can load, modify, and print files; save files in a personal Library that you've created, printed, or want to print; find new objects in the Thingiverse to print; and access instructional and troubleshooting videos. To print, you first press the Prepare tab in a taskbar near the top of the screen. This brings up a representation of the print bed, which fills the screen. You then pull down the File menu in the screen's upper-left corner and click on Add, which opens Windows Explorer. You then click on the 3D file of your choice (in STL or OBJ format), which will load and appear on your monitor. By pressing icons on the left side of the screen, you can zoom in or out, or move, rotate, or resize the object.

At the screen's upper right are a line of tabs. The Settings tab opens a dialog box that lets you choose between low (300-micron), standard (200-micron), and high (100-micron) resolution and add a raft (a small platform of plastic underneath the object to provide support, which can be removed when the print is done) or supports. You can open a Custom menu that lets you change

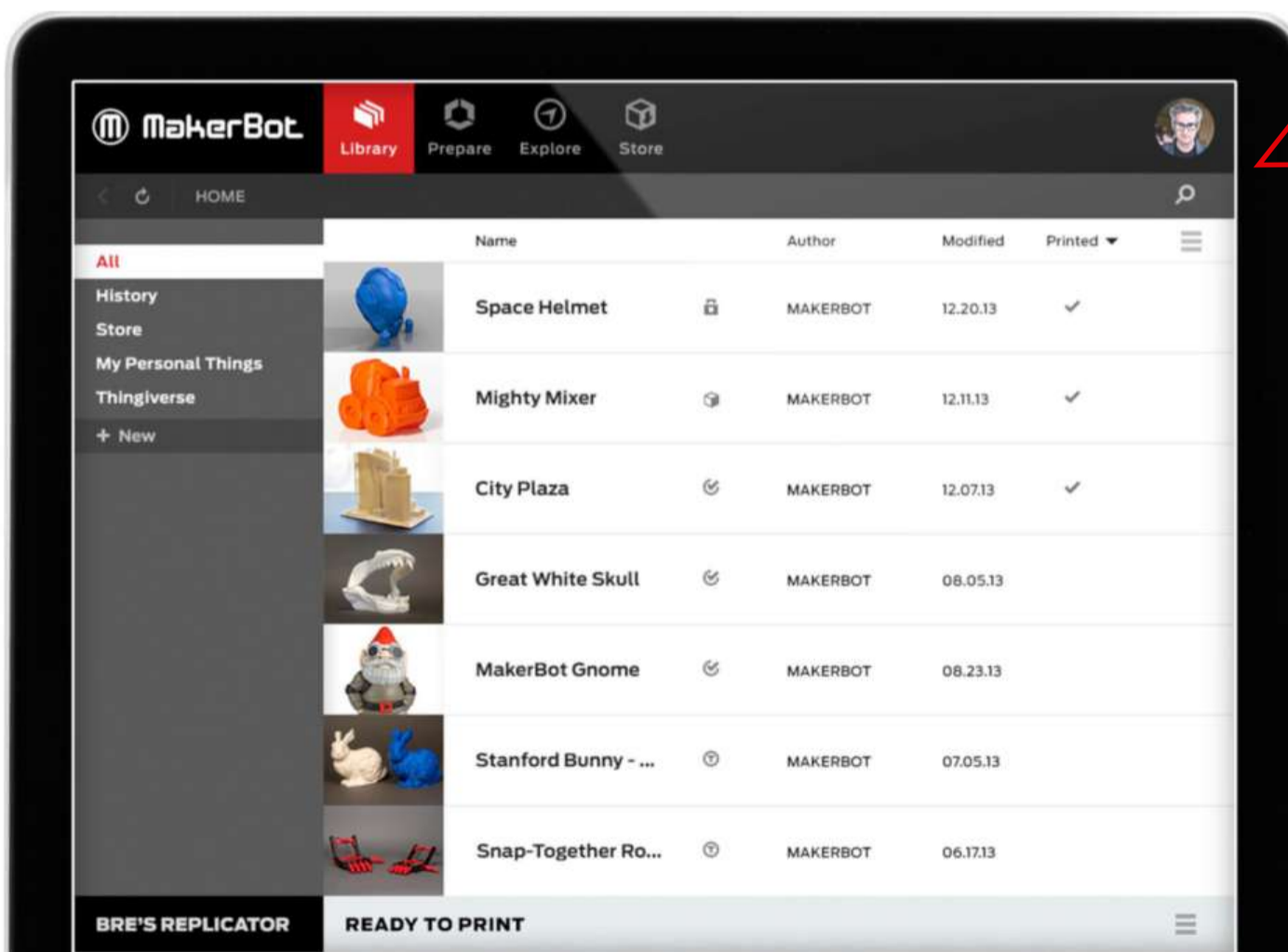

**DESKTOP
DOWNLOAD**
The free MakerBot Desktop software provides a wide range of tools for finding, modifying, and printing 3D object files on the Replicator.

printing speed, extruder temperature, amount of infill, and more. The Export to File tab lets you save a file in MakerBot's .thing format to a USB key (or other drive) for printing out. In the screen's upper-right corner is the Print tab, from which you launch your print, provided your computer is connected to the printer. That's printing in a nutshell. Really, all you need to do is load the software, add a file, tweak it if you're so inclined, and hit Print.

PERFORMANCE

I printed more than a dozen test objects with the Replicator, using all the printing methods described above except Ethernet. With the exception of one misprint, output quality was consistently very good to excellent. Print quality is a tad better than with the Ultimaker 2, despite the fact that that printer printed the test objects at a resolution (100 microns) that's twice as fine as the Replicator's 200 microns. (We print nearly all our test objects at a printer's default resolution.) The Replicator did particularly well in printing out a test object comprising various geometric forms.

A frog was the one object the Replicator had a problem with in testing. Many printers have trouble printing out its legs, which can become detached from the body and often reattached in the wrong place. The Replicator simply scuttled the job, instead forming a blob of plastic around the extruder nozzle. By default, we test this object without supports or a raft; when I added a raft, the frog printed out with its feet in the proper place and showing good detail.

I had no extrusion problems when testing the Replicator, with no layering issues or extruder jams. Filament flow issues often reveal themselves as gaps in a print's layers, or the printer will stop extruding altogether, which was the case with the first Makerbot 3D printer when we reviewed it. The MakerBot Replicator 2X, a dual-extruder model, experienced clogs in each extruder at different times, which necessitated taking apart the extruders to clear them, a frustrating and time-consuming process.

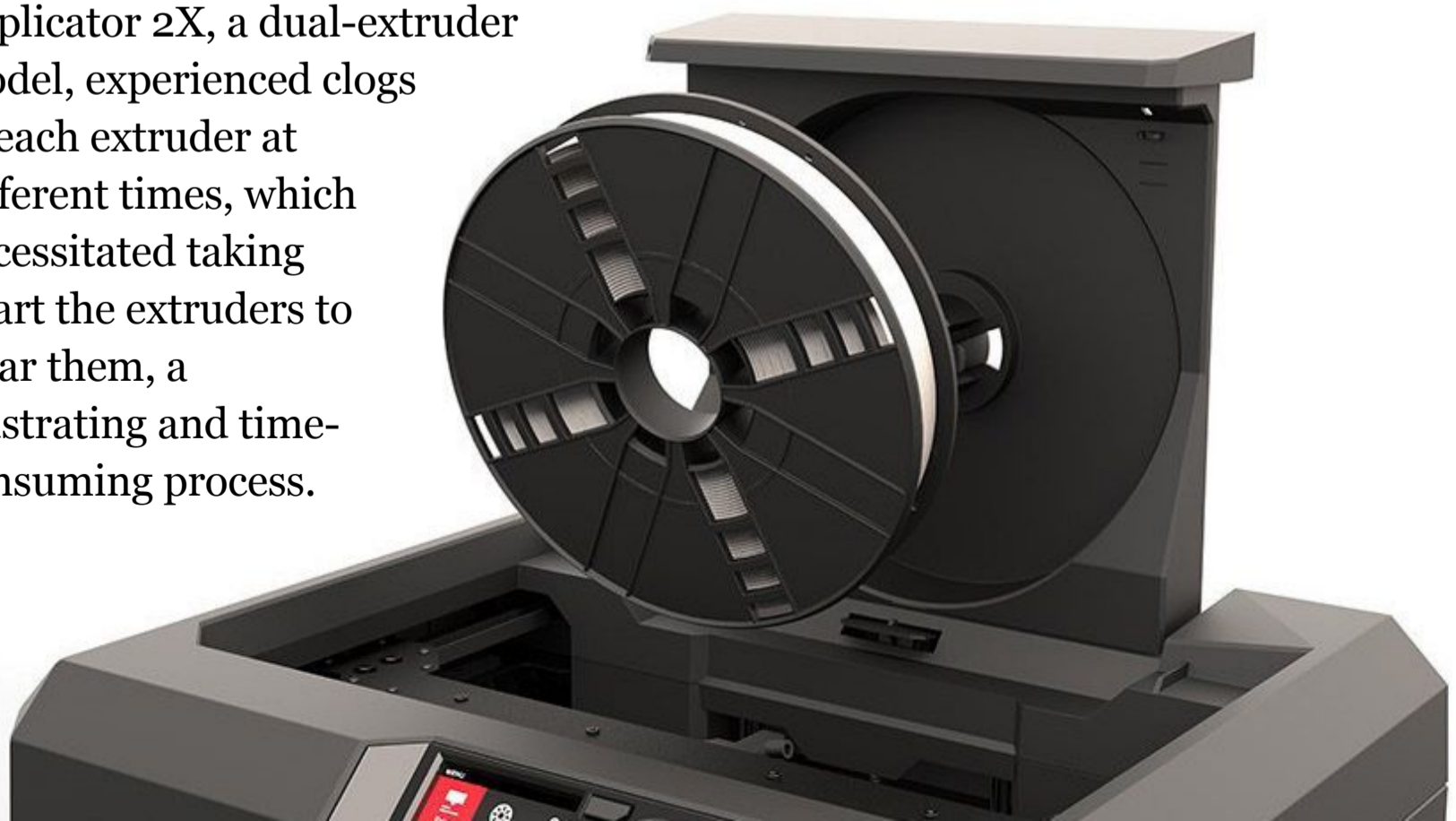



The Replicator's design should keep both adults and children about as safe as is possible with an open-frame printer.



SAFETY AND NOISE

With open-frame printers, there is always a risk that you could get burned by touching the hot extruder. The Replicator minimizes the chances of this by placing the extruder nozzle behind the extruder assembly, making it difficult to reach from the front or sides. From the top, it's blocked by the carriage that holds and moves the assembly. The Replicator's design should keep both adults and children about as safe as is possible with an open-frame printer.

I didn't notice any fumes from the hot plastic with the Replicator, and nor did I expect to. Although acrylonitrile butadiene styrene (ABS) plastic filament can emit a burnt-plastic odor that some people find objectionable, PLA is nearly odorless.

Like many other 3D printers, the Replicator makes a range of sounds from motors revving to soothing electronic melodies. It's louder than most printers, due in part to its open-frame nature. Several nearby coworkers mentioned the noise to me on several occasions during testing. If you buy this printer, you'll want to find a place for it where it won't disturb others.

OTHER CONSIDERATIONS

Perhaps the Replicator's main shortcoming is that its maximum object height is 5.9 inches, so it can't print objects as tall as some of its competitors can—the Ultimaker 2 can print objects up to 8.1 inches, the LulzBot TAZ 5 3D Printer goes up to 11.7 inches, and the Ultimaker 2 Extended can build objects up to a full 12 inches. If the ability to print tall objects is important to you, one of those models might be a better choice. If you want to experiment with different types of filament, you can do it now with either LulzBot's Mini or TAZ 5, as both support numerous filament types. (Remember, though, that within the next year, MakerBot should have its own exotic composite filaments, although they will be PLA-based.)

The MakerBot Replicator is an impressive 3D printer, and stands out for its combination of ease of use, smooth and consistent operation, high print quality, and variety of connectivity choices. It's a particularly good choice if you're a product designer or engineer who needs to rapidly make prototypes, an architect or artist, or if you work in a shop involved in short-run manufacturing. And its user-friendly setup makes it a good choice for schools, or well-heeled consumers. It costs a lot, but you get a lot of value in return.



GET ORGANIZED

**Make Your Job
Search Easier**

TIPS

**Encrypt Data on
External Drives**

HOW TO

Customize Windows 10

CONNECTED TRAVELER

**Room Service Robots
Are Now Checking In**

Digital

Life

Make Your Job Search Easier

BY JILL DUFFY

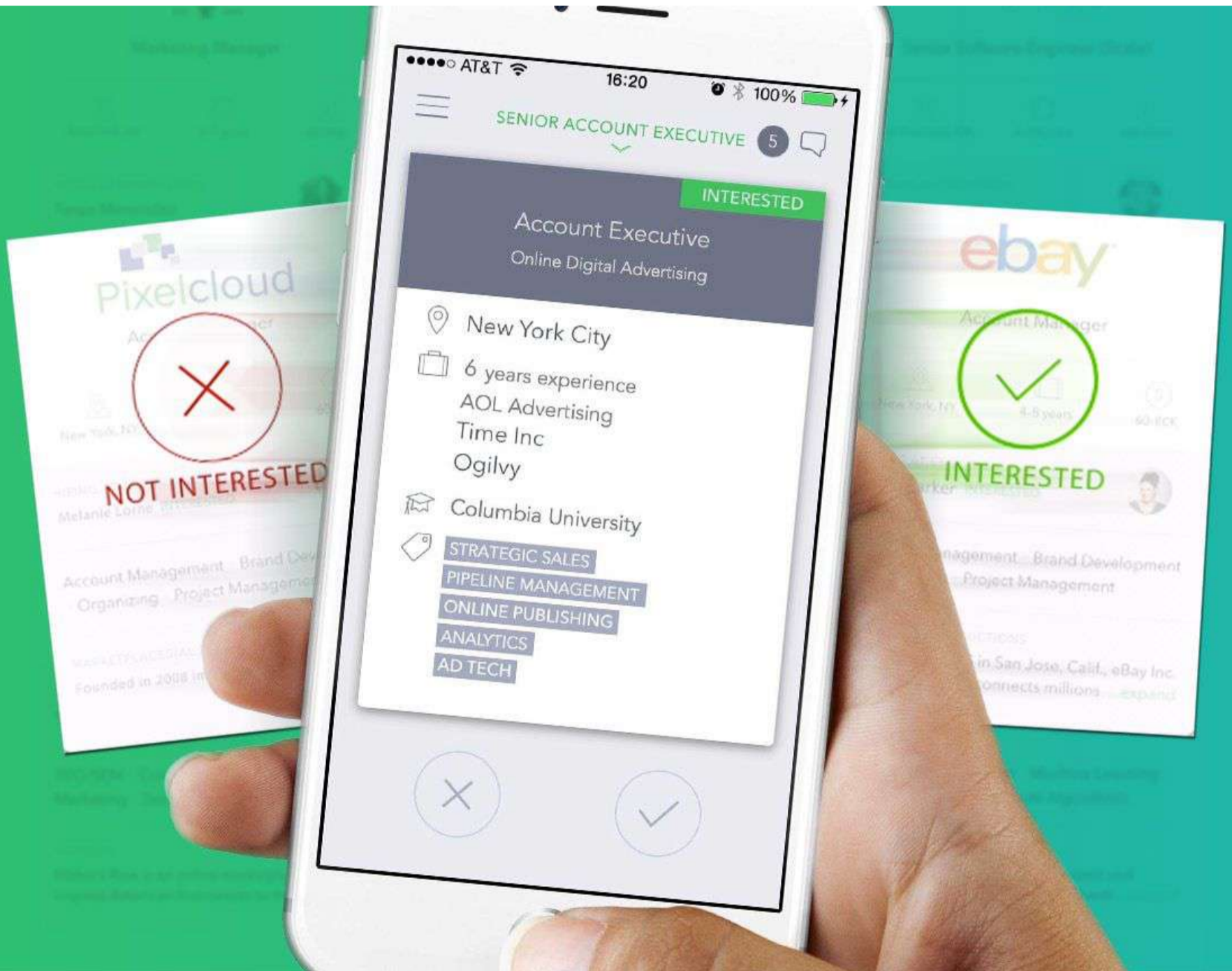

Who can make sense of the job market these days? Competition is fierce. The unemployment rate in the U.S. has been fairly stagnant, according to the Bureau of Labor Statistics. And with the tech industry always trying to “disrupt” marketplaces, it’s hard to know which job search services and applications are worth using and how to get the most out of them. Here’s some advice for how to make the best use of sites, apps, and other software to organize your job search.

BOOKMARK JOB SEARCH WEBSITES

If you are an active job seeker who's scouting daily, bookmark job search websites and save the links in your browser's bookmark (or favorites) folder or toolbar. The links should include general job boards, such as Indeed.com, as well as those that are specific to your industry (JournalismJobs.com for journalists, for example, or Dice.com for technology and engineering professionals) and geographic region (such as austin.craigslist.org for the capital city of Texas). If you're not sure which job websites your industry or city prefers, ask friends and colleagues who might know.

A few general sites that I recommend are LinkedIn, Indeed, Glassdoor, SimplyHired, and CareerBuilder. Depending on your field and location, social networking sites like Twitter and Facebook could easily make your list, too.



BOOKMARK CAREER SITES OF COMPANIES YOU ADMIRE

Do you have a dream job with a specific employer? If that company or organization has its own website for job postings, bookmark it, too. Sometimes companies don't post all their open positions on general job boards (it's expensive), so you'll want to keep an eye on the company listings. Plus, a company may post a job ad on its own site before listing it elsewhere, meaning anyone who sees it there first will be one of a much-smaller batch of early candidates, and that could improve your chances.

DIVE INTO APPS

Applying to jobs via a mobile app still seems a little bonkers to me (the typos!). But don't write off mobile apps for your jobs search entirely. A few novel apps offer unique opportunities, usually in that they try to match job seekers with employers the way dating apps might try to match two people. Think of these apps as for job browsing on the go, or for getting alerts quickly so you don't accidentally snooze a potentially career-changing advancement. Here are a few I find worthwhile.

Anthology (formerly Poachable) says it's for people who are "open to opportunities" but aren't necessarily looking hard for their next position. Anthology has you fill out a profile with your experience and interest, and then it aims to match you with employers who are looking for someone with your characteristics.

Savvy (formerly Poacht) is an app and website with an angle on advancing the careers of female professionals. It's still in its early days, but it's similar to Anthology in some ways, and seems to have an emphasis on executive positions and tech jobs.

Switch has you fill out a profile to describe your experience and career desires, and then it shows you jobs that might be a fit. When you review the jobs, you swipe left or right to indicate whether or not you're interested. Employers do the same thing while looking for candidates (similar to the way Tinder works). If you swipe right on a job and the company swiped right on you, you'll both see that you are a possible match.

CONSOLIDATE AND ORGANIZE YOUR APPLICATION MATERIALS

You need to tailor your resume and cover letter to every job application. That does not mean you have to write a fresh one from scratch each time. Instead, have one or two templates you can use as starting points, then make sure that each application you create from the templates contains only the most relevant details about your experience as it relates to the job at hand. If you typically have to send additional materials, such as code excerpts, writing samples, or a portfolio of your work, using templates of them to spin out variations is helpful, too.

Additionally, create a folder on your computer for holding your resumes, cover letters, job descriptions, and any necessary extra materials. Saving your variations is especially helpful if you get called for an interview—you can pull up exactly what you sent in and review it beforehand so you're fully prepared.

THE SWITCH APP IN ACTION.



DECIDE WHEN TO SEARCH

Are you searching for jobs daily? All day long? Saturday mornings? Set aside a time for searching and stick to it. Block it off on your calendar or to-do list. This advice is especially useful for people who are already employed, when making time for a job search is one of the biggest challenges. If your search will be more passive, I definitely recommend using mobile apps and notifications so you're aware when a good opportunity may be on the table.

CAST A WIDE NET

Sometimes a dream job doesn't look like a dream job from the description, so cast a wide net. During the job search phase, it's okay to say "yes" more than you think you should. People who write job ads are usually pressed for time and short on staff. Keep that in mind and you might start to see how many job postings are more like loose descriptions, rather than roles that are set in stone.

Name the files using the employer's name and job title, which will make it very easy for you to keep track of the jobs to which you've already applied. For example, a resume to the *New York Times* for a copy editor position might be 2015-resume-NewYorkTimes_copy-editor. This way, if a job listing comes up but you're pretty sure you've seen it before, you can easily check your folder of resumes and know within moments whether you've already applied to it.

DATES, DEADLINES, AND SUCCESSES

Another set of information you'll want to track and save while applying to jobs is the application deadline (when applicable) and the date you submitted your materials. A spreadsheet can help with this, but you can do it with email, too—just set up folders so you can sort and search more effectively (it's easy to lose track of important information when your inbox is too crowded with mail).

You'll also want to record the responses to the applications you send. Whenever you get a reply email, phone call, or request for an interview, it means you've done something right in the application. Review your materials against the job description and see if you can figure out what worked. If you can identify the best moves you're making, you can make more of them. When you get a call, highlight the line item on your spreadsheet or mark the sent email as "important."

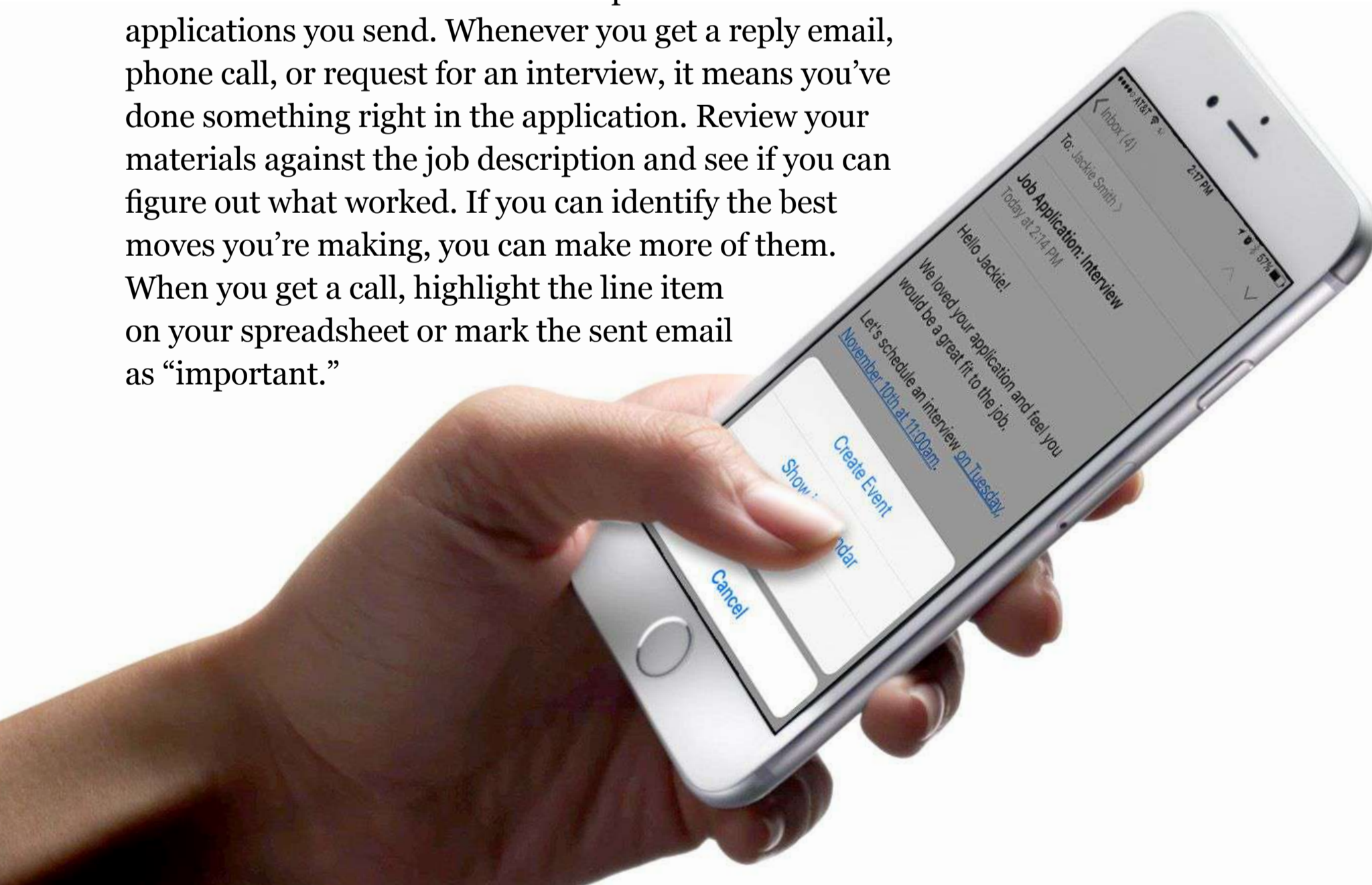

CLEAN UP YOUR ONLINE IDENTITY

Assume that, after you've submitted your application for a job, someone on the hiring team is going to search for your name online. Spend some time cleaning up your online identity, including tweaking privacy settings on sites like Facebook if that's a concern. Make sure that the results are either neutral or speak to your career and experience. In some job fields, you can get away with having a stronger online personality than in others. Know what it is you want to convey to potential employers, and make sure public search results convey it.

NETWORK, NETWORK, NETWORK

Though technology can do a lot to help you with your job search, the human factor remains one of your most important assets. Tell people you're on the job market or open to new opportunities, or whatever it is that best describes your circumstances. Network! Talk to anyone and everyone. Stretch your social limits. And for goodness sake, be positive while you do it! People like positive energy, so be excited about new possibilities rather than grumpy about your current position. People are attracted to those who seem eager and passionate. Which reminds me: Be passionate about the things you say you're passionate about on your cover letters, but, you know, in real life.



Resume

Experience

Technical

Roasted lasting huggable n
great duty lighter, all sav
ries millions market b
res lifetime spring e
lively-back energ

Customize Windows 10

BY LANCE WHITNEY



Like previous versions of Windows, Windows 10 comes with a host of features and options set up the way Microsoft thinks you might prefer them. But also like before, Windows 10 lets you customize many of them, so the OS performs more to your liking. How to tweak them? Read on, and you'll discover ten ways to customize Windows 10, including where to find the appropriate settings and just how to adjust them. Having made some of these changes, hopefully you'll find Windows 10 an even more appealing place to work and play.



Default to Start Menu or Start Screen

In Windows 10, Microsoft offers a choice between the old-style Start menu on the Desktop and the more touch- and tablet-focused Start screen that was introduced in Windows 8. Let's say your PC already has the Start menu set up as the default, and you want to switch to the Start screen. Go to the Personalize menu (click on the Start button, then click Settings, then click Personalization, or right-click on the Desktop and select Personalize from the menu that pops up). Select the category for Start. In the right pane, turn on the switch to "Use Start full screen." Click on the Start button, and you'll now see the Start screen in all its full-screen glory. To switch back to the Start menu at any time, just turn off that same switch.



Change the Start Menu or Start Screen's Transparency Color

Don't like the default color of the Windows 10 Start menu or Start screen? No problem. You can give it a different paint job that's more suited to your tastes. You can also make the Start menu or Start screen transparent to give it a bit more style. In the Personalization menu, click the setting for Colors. With the option "Automatically pick an accent color from my background" off, you can select a color from the palette below to use as an accent on the Start menu or screen; turn it on to have Windows choose a color for you. Choose "Make Start, taskbar, and action center transparent" if you'd like Start to partially show windows and other elements beneath it.



Change Your Background Image

Not crazy about the picture that Microsoft uses for your background image? You can easily change that. Microsoft offers its own gallery of photographs, but you can also use one of your own images if you'd prefer to spice up Windows 10 with a more personal touch. Go back to the Personalization menu and make sure you're in the Background category. On the right pane, click the drop-down menu under "Background." Choose Picture, Solid Color, or Slideshow.

Let's choose Picture for this option. If you wish to use a picture from Microsoft's small gallery, choose it from the row of thumbnails. It is then applied to your background. If you wish to use a different picture stored on your computer, click the Browse button and navigate to the file of the picture you wish to apply. You can also fiddle with the actual size and centering of the background image by resizing or realigning it. In the "Choose a Fit" section, select the desired fit for your background image (the options are Fill, Fit, Stretch, Tile, Center, and Span).



Customize the Lock Screen

If you don't like the picture Microsoft chooses for your Lock screen image, you can change that as easily as you can your background image. But you can further customize the Lock screen by choosing which apps and information you wish to see on it before you even log in. For example, you can opt to view a weather report, your latest email, your upcoming appointments, or other useful details for the day ahead.

Go to the Personalize menu and select the "Lock screen" category. On the right pane, click the drop-down menu under "Background" to choose a Picture or a Slideshow. If you want a picture, either choose one of Microsoft's images from the thumbnails or click the Browse button to navigate to an existing picture stored on your computer. Beneath these options you can select one app from which you wish to see detailed information on the Lock screen, or up to seven to give you quick status updates.

Once you've made these choices, log out and then log back in to see your new Lock screen in action.

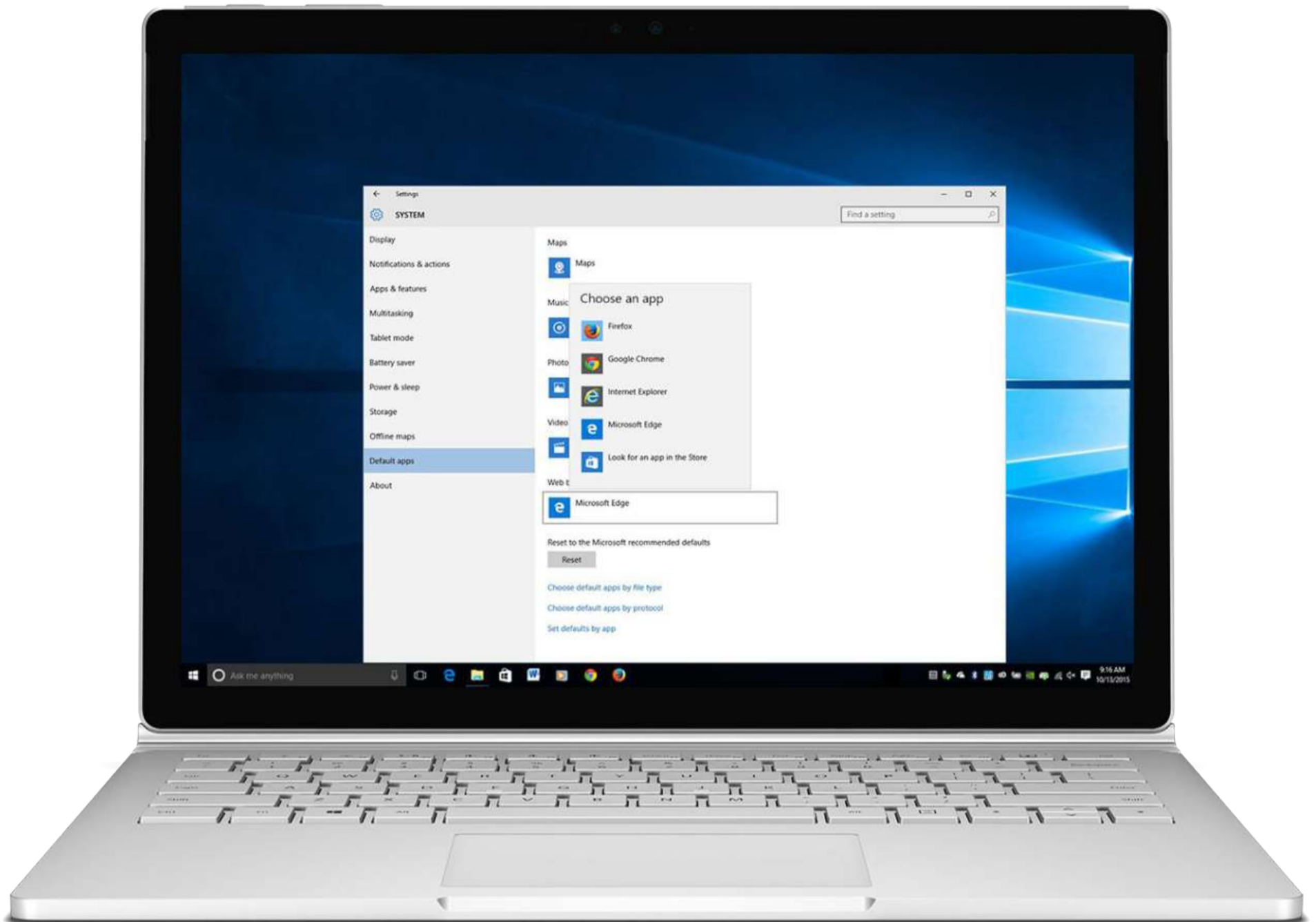

Change the Default Web Browser

There's a new Web browser in Windows town, and it's called Edge. Designed to replace the venerable Internet Explorer, Edge is simpler and more streamlined, without all the toolbars and other baggage found in IE. Microsoft wants you to use Edge so much that the company has set it as the Windows 10 default. If you prefer to use another browser, that's easy to set up.

Click on the Start button and then click on Settings. Click on System, and then the "Default apps" category. Scroll down the right pane until you see the option for "Web browser." Click on the browser listed there to change it to the program of your choice.



Bypass the Login Screen

Like Windows 8 and 8.1, Windows 10 sticks you with a login screen that requires you to enter a password or PIN or other type of security. That's probably a good idea if you travel a lot with a laptop, work in an office, or share your computer with other people. But if you use your PC at home or in a private place (or you're the only one who uses it), you can dispense with the login process entirely if you wish.

To do this, type "netplwiz" in the search field to the right of the Start button, then click on the program entry at the top of the search results. A user account window pops up. Click your account name, then check off the option that reads, "Users must enter a user name and password to use this computer." Now log off or restart your computer. Windows will now bypass both the lock screen and the login screen and deposit you directly at the desktop.

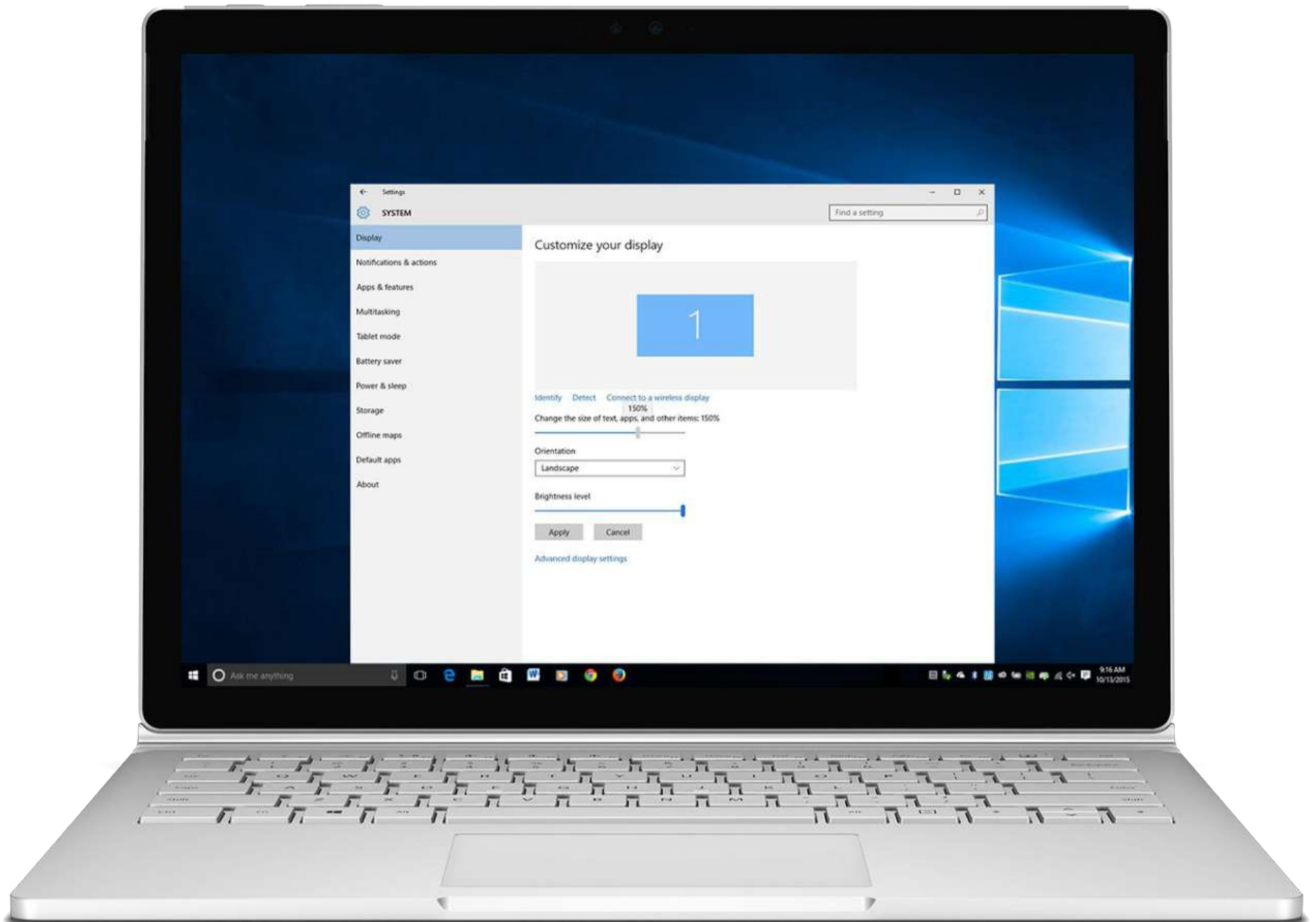

Change the Windows Font Size

Windows uses a certain default size for the fonts and text that appear throughout the operating system. This includes the text on the desktop, the text in menus and title bars, and the text in other locations. Let's say you find the default text too small. Can you make it larger? But of course!

Right-click on any empty area of the desktop and select "Display settings" from the pop-up menu. In the Display category, move the slider bar under "Change the size of text, apps, and other items" over to the right to make those items larger. Then scroll down and click the Apply button. Windows then prompts you to log out. Log back in and you'll see that all the Windows display text is bigger, an especially nice feature for those of us whose eyesight isn't quite what it used to be.



Customize the Taskbar

The taskbar is a handy place for storing icons for your apps, toolbars, and other items. And, as with other features in Windows 10, you can customize the Taskbar to display only those items for which you want quick access. You then keep the taskbar from getting too cluttered and overrun with icons you may rarely or never use.

To get started, right-click on any empty area of the taskbar to bring up a customization menu. In the Toolbars menu, you can choose which toolbars you wish to see on the taskbar by clicking the ones you want. The Show Task View button displays a button at the left of the taskbar that lets you open the Task View to create and view virtual desktops for organizing apps, windows, and other content in sophisticated ways. The Show Touch Keyboard button displays a virtual on-screen keyboard that you can use to enter text in any Windows application (obviously, this is a good one for tablet users to keep around). And the Search option lets you hide the search button, shrink it to an icon, or display it at its full width.

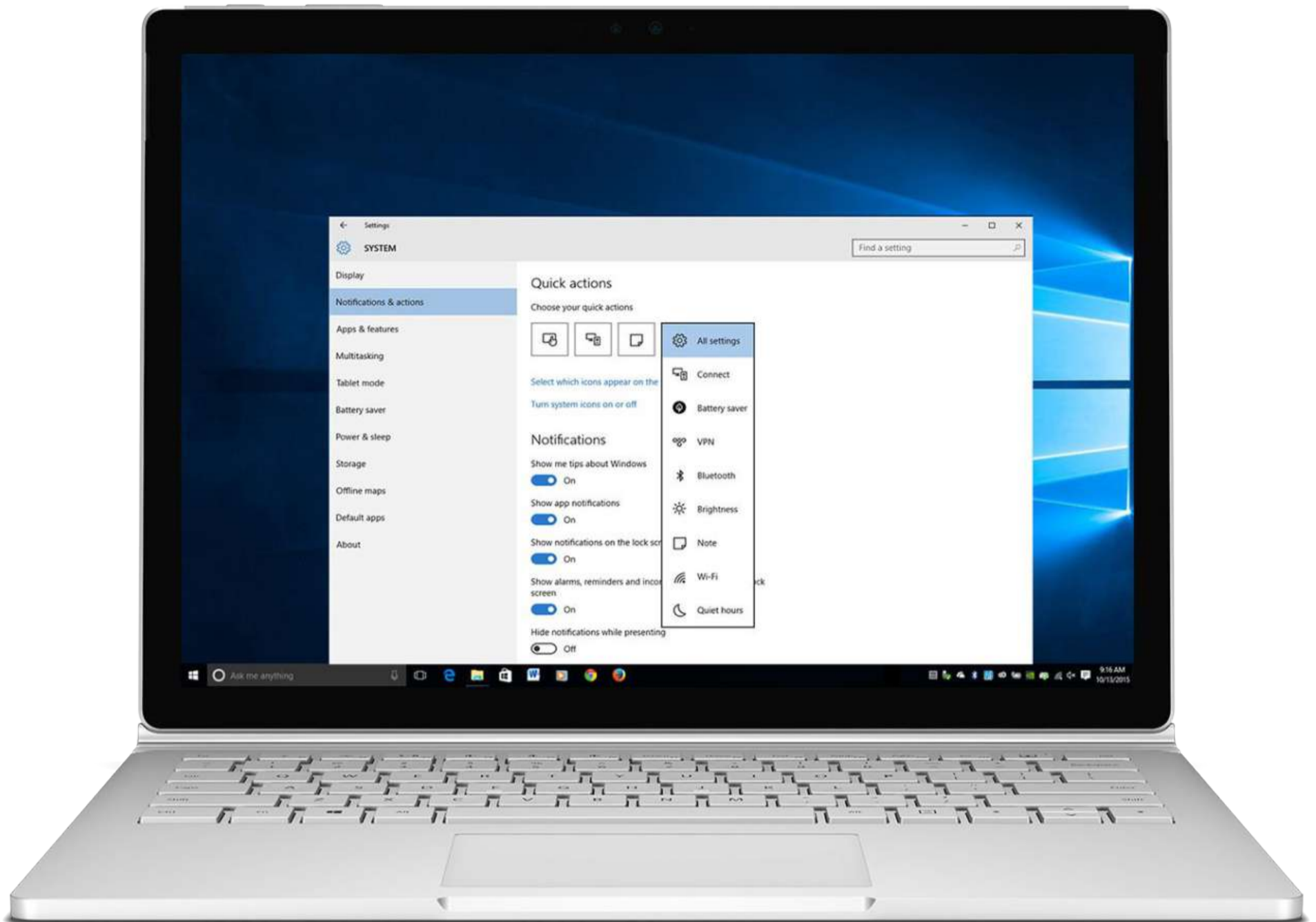

Customize the Action Center

The Windows 10 Action Center provides quick access to certain features and commands. You can't remove or add features at this point, but you can determine which features appear when the Action Center notifications panel is collapsed.

Click on the Start button and then click on Settings, then click on System. Select "Notifications & actions." Under "Quick actions" you can specify the four actions, in order, you want to see displayed first in the Action Center. After you've set these up, click on the Notification button in the system tray. If the Action Center is collapsed, you'll see buttons for the four quick action items that you select. You can also click the Expand link to see more quick actions.

The next time you want to access any one of the eight quick actions, just click on the Notifications icon, and they'll all be available to you as long as you keep the Action Center expanded.

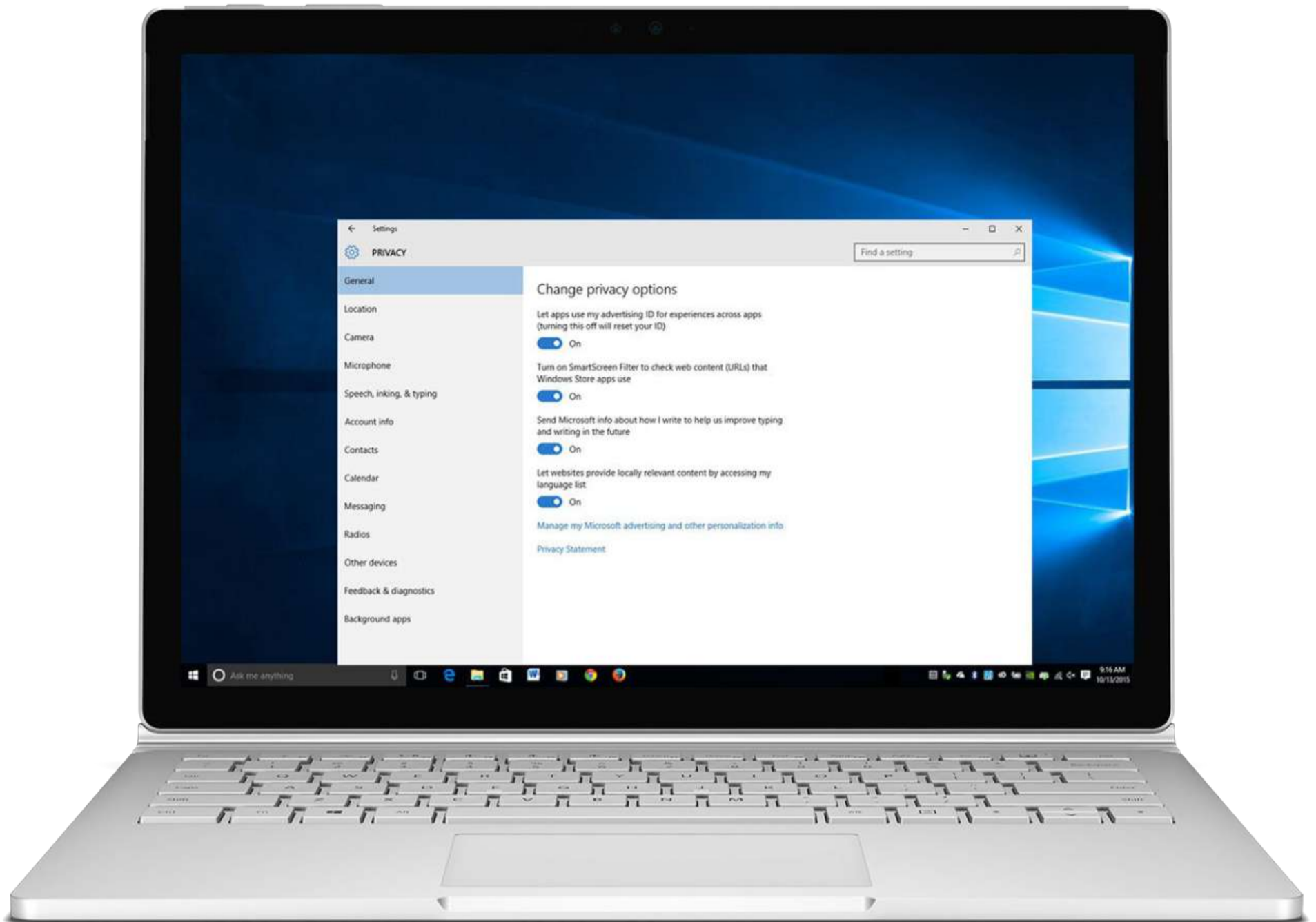

Change Your Privacy Options

In Windows 10, Microsoft collects certain information about you for advertising purposes, but it also tries to improve certain apps based on your personal preferences. If this behavior concerns you, there are some tweaks you can make. To get started, click on the Start button, then click on Settings, then select Privacy.

In the General category, you can adjust the most significant settings, which allow advertisers to serve you personalized ads in Windows Store apps, filter out malicious Web content in apps you download (while perhaps also blocking some legitimate content in the process), log your keystrokes to help Windows better recognize your handwriting, and allow some apps serve up content based on your language.

You can also browse through the other categories on the left pane of the privacy section to determine which settings you may want to enable or disable. Several of the sections provide a link to a Privacy Statement or other webpage that may help you decide which settings to turn on and which ones to turn off.

Encrypt Data on External Drives

BY ERIC GRIFFITH

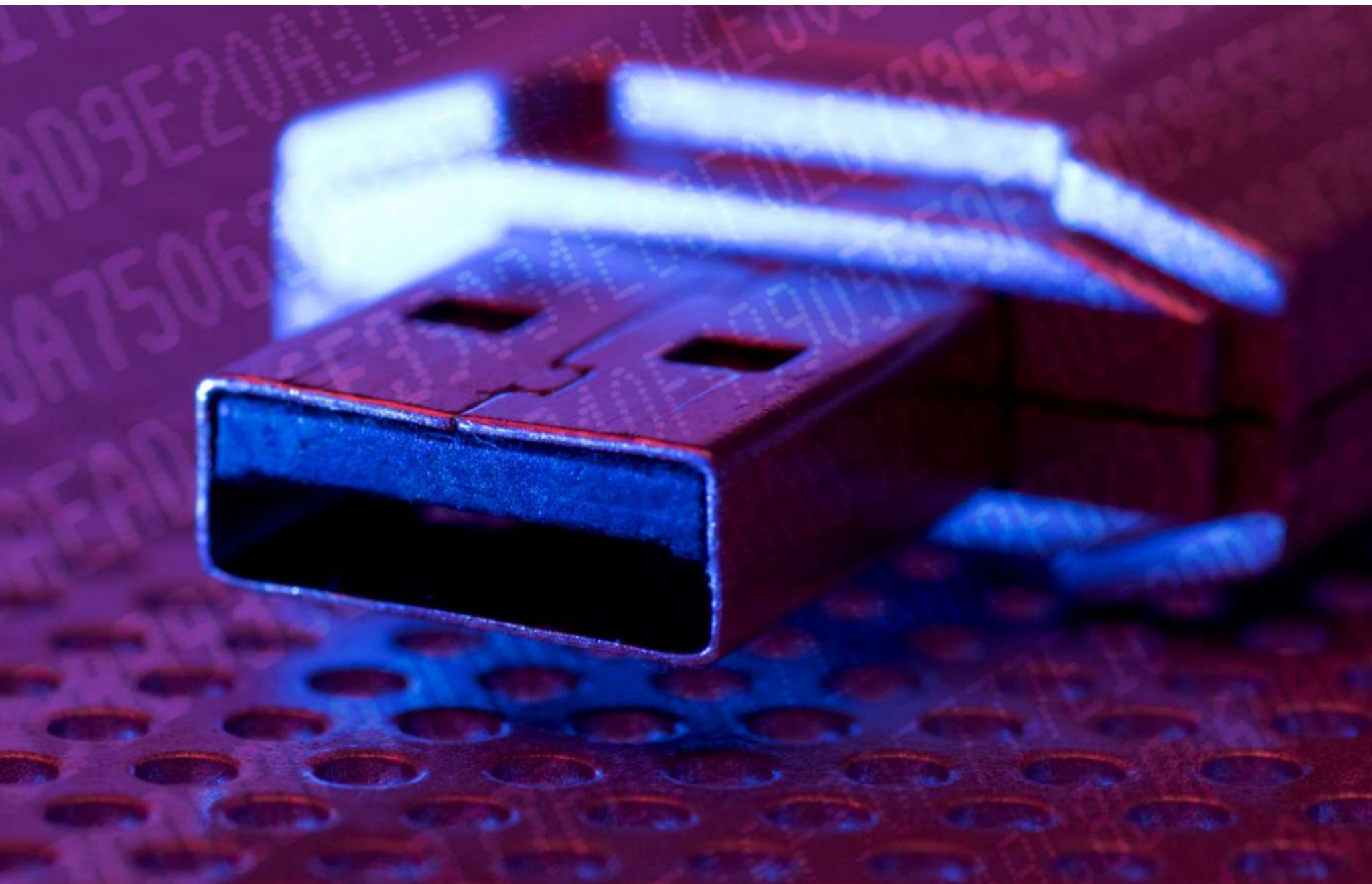

It's not hard to lose a USB flash drive; it's even easier to steal one. If you're the victim of such a theft, panic is understandable. There could be work documents, private pictures, your kid's birthday party video, or notes for an amazing NaNoWriMo novel—anything—on that drive. It's unlikely to be the only copy—this is the age of online backup and sync, after all. But if you're crazy enough to trust your most important, irreplaceable data to a device that's even easier to misplace or forget than your keys, then you should at least make sure that data is secure.

What you'll need is software for encrypting the data, and that software has to be portable, in that it runs on any PC without installation, as it will likely run from the flash drive itself. Note that these solutions also work with any external hard drive, for the most part, plus your much-harder-to-steal internal hard drives and solid-state drives (SSDs).

ENCRYPTION SOFTWARE

Your first choice should always be to try a free software solution. A current favorite is VeraCrypt. It's free, open-source, and Windows-only. It lets you create a volume or vault on your USB flash drive that only you can access, encrypt an existing drive (as long as it isn't system-necessary, like your C: drive), or encrypt the entire system drive so anyone who tries to install programs or read and write files would need to enter a password each time. That last one is overkill; stick to the first few options.

The volumes created by VeraCrypt can be standard (visible, but only the person with the password can get access) or hidden. With the latter option, even if you're forced to give up the password, it's unlikely anyone will be able to find your data to get access anyway.

When you go to install VeraCrypt, there's an option to Extract. Do that and extract the files to your USB drive. That makes a portable version, so you don't need to have VeraCrypt on every system that you'll plug the drive into—but it does have to be on an administrator-level log-in on the PC.

The VeraCrypt site has an excellent step-by-step tutorial. Another free option is CipherShed; both it and VeraCrypt are offshoots of the late, great TrueCrypt. BitLocker, which comes with select versions of Windows (the non-"Home" versions), can also be used to secure USB or external drives. If you prefer to pay, check out the \$12.99 EncryptStick, which is available for both Mac and Windows.



VERY VERY VERACRYPT

If you're looking for an easy-to-use way to encrypt data on your Windows PC, VeraCrypt is a good, free choice.

SECURE FLASH DRIVES

There are millions of USB flash drives around—I have three of various capacities littering my desk at any given moment. So using third-party software to secure their contents makes great sense. But if you want security from the start, plenty of drives come with security built into the hardware.

A few select flash drives have a number pad right on the drive itself. You enter a PIN before you can access the contents. They include the Aegis Secure Key 3.0 (right), a \$65 flash drive equipped with FIPS 140-2 Level 3 encryption (it comes in 4, 8, 16, and 32GB versions).

If you think reaching for the number pad is an issue, there are also a few biometric USB flash drives. IronKey, by Imation, is a pretty well-known name for secure drives; its F200 uses a built-in finger-swipe, and throws in multifactor authentication for your files. The price, of course, is high, starting at \$189 for the base 8GB model and shooting to \$649 for 64GB. We give the F200 good marks for security, but its performance is lacking.

But you don't need to have anything fancy built into the hardware of your USB flash drive to be secure. Several models come with encryption software. It's held in a partition of the drive itself and looks to Windows like a CD, so it can automatically activate when inserted and give you instant access. Some options include the Kanguru Defender 2000 (4GB, \$69), the IronKey F150 (8GB, \$139), and the Kingston DataTraveler Vault Privacy 3.0 (4GB, \$35). All of these listed are base models; you can always get more capacity by paying more. For savings, be sure to compare on Google or using Amazon.

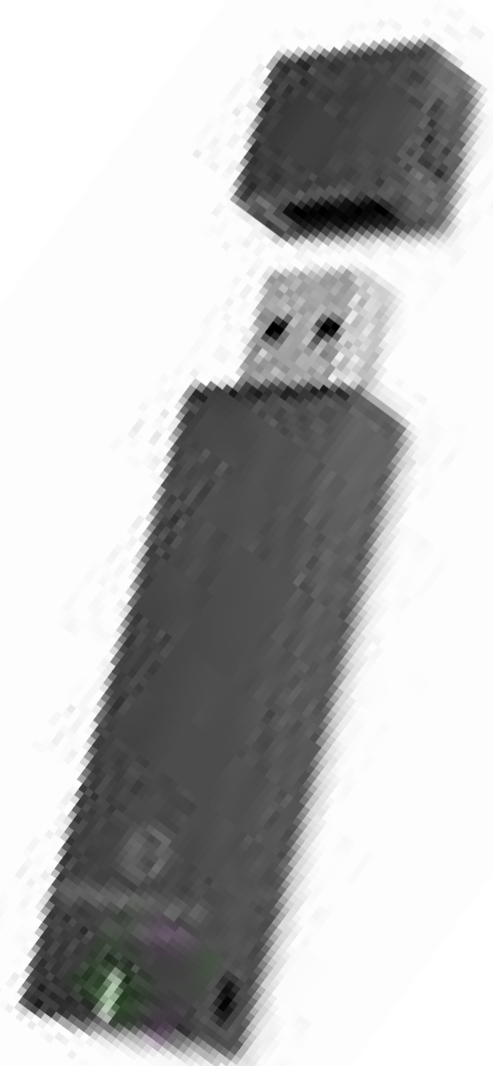

Room Service Robots Are Now Checking In

BY SOPHIA STUART



40-ROOM DASH
Savioke's Relay is a revolutionary new robotic butler that brings a special efficiency to serving guests at the Crowne Plaza San Jose—Silicon Valley hotel (where it's been named Dash).

There's a new staff member at the Crowne Plaza San Jose—Silicon Valley: a robot named Dash.

Dash, from Santa Clara-based Savioke, stands 3 feet tall and looks like a slightly taller and trimmer R2-D2. He sports a 20-inch circular base so he can rotate in place, and is coated in soft-touch polyurethane paint. He self-docks in the lobby at the Crowne Plaza near the gift shop, waiting to receive instructions.

During a recent stay, and for the purposes of research, I “forgot” to bring toothpaste to the hotel. A quick call to the lobby and Dash’s storage unit opened, supplies were placed inside (he can hold up to 10 pounds), and the hotel room number was tapped into his screen.

Dash moved off of his docking station autonomously, zoomed to the elevator, paused in front of it, and used what the hotel staff referred to as “robot telepathy” (aka Wi-Fi) to call the elevator and program it to take him to the correct floor.

“What’s that?” asked a businessman who looked up from his road-warrior laptop in surprise.

But Dash had no time for small talk. He slipped into the elevator and turned to face forward, as a human would. “Heading to the tenth floor,” his communication screen displayed, to let other hotel guests know that he was on a mission and not a rogue device on the run.

Once the elevator arrived at the correct floor, Dash moved quickly into the hallway, the LED ring around his circular base projecting a purple light (the color can be customized to a particular brand). That light is intended to glow underneath a guest’s door in a very sci-fi way to signal Dash’s arrival, but he’ll also call your room when he gets there.

I opened the door and after a little piping electronic data transfer sound, the top lid opened to reveal the toothpaste supplies. “Please remove your items,” the screen said. I did, and the screen requested feedback. I gave Dash an all-star rating, and he emitted a happy response and shimmied his torso back and forth in delight—the whole communicative aspect is truly adorable—before zooming away. Dash’s sensors alerted him to an obstruction in the hallway, and he neatly avoided a tray left outside someone else’s room.

How did Dash come to live in this hotel’s lobby? Sales manager David Wang told me that Savioke approached the Crowne Plaza several years ago and asked what it might do with a robot.





The team was skeptical, but “we brainstormed a bit about tasks that would be useful, like delivering amenities,” Wang said. “At the time, we really thought a hotel robot was more of a fantasy than a reality, something that’s not going to happen for at least ten years. But here he is.”

Though Savioke’s robot is officially known as the Relay, the hotel held a staff naming competition and Dash was the clear winner. “It suits him,” Wang said.

Adrian Canoso, Savioke’s cofounder, said that the company placed enormous emphasis on human factors when creating its robot. “We wanted children and people in wheelchairs not to feel overwhelmed, so that’s why he’s 3 feet tall,” Canoso said. “We can have the robot do an emergency stop going down a ramp and maintain stability within a few centimeters. We feel comfortable having Dash around hotel guests of any age.”

Savioke and Crowne Plaza communicate regularly on Dash’s progress. “We capture an enormous number of data points to improve efficiencies,” said Canoso. The company knows how long a certain task should take, so if Dash is delayed, he will send an alert to the front desk via an iPad app requesting that someone check on him.

If Dash does well in Silicon Valley, Crowne Plaza will consider rolling out a fleet of robots at its other properties. A Relay is also at the Holiday Inn Express in nearby Redwood City, and Savioke expects other hotel deployments in Sunnyvale, Los Angeles, and elsewhere by year’s end.

For now, Crowne Plaza guests find Dash intriguing. “Most people pet it,” said Wang, “and almost everyone says, ‘I want one at home!’” From firsthand experience, it looked like Dash fits in well. But then again, this is the Crowne Plaza in tech-savvy Milpitas. We’ll have to see whether the rest of the U.S. is ready for robot delivery.



Augmented Reality Is Becoming Our Reality

I first saw virtual reality (VR) headsets in the 1980s, when a team at MIT virtualized a VGA screen using a miniature electroluminescence display. The person wearing the goggles did computing chores with no monitor, and a virtual screen floated right in front of him. This idea evolved into Sony glasses that let you watch movies on a virtual screen 100 feet wide. Other headsets gave you 3D.

That entire idea has simplified to the point where you now have Google Cardboard, a headset made of actual cardboard into which you drop a mobile phone running an app to simulate what you get from the Oculus Rift standalone VR unit.

Now we're seeing a shift toward what's called "augmented reality" (AR). Google Glass, a product I've ridiculed with some consistency, was one of the first ventures into this realm. It's all about getting a layer of data and information that overlays your view of reality.

Let's say you're in biology class with a frog on the table. With the proper AR software, a device can identify the frog and add labels on the screen with pointers identifying the heart, gullet, legs, and head. Move the camera around, the identifiers adjust appropriately. Voilà! Augmented reality.

This can also work with a mobile phone. Walk through Paris, hold up your phone as you get near the Eiffel Tower, and see all sorts of information. This particular example has been a holy grail of computing for as long as I can remember.

Microsoft is expressing an interest in this field, and its HoloLens product is headed in this

direction using a headset. A specialized AR headset could still work with the mobile phone in the cardboard box. It would just need to utilize the phone's camera so the user can also see real-world objects. That way they don't kill themselves while playing some game or examining the frog.

(As an aside, the liability issues for these devices that require you to wear goggles and yet let you move about are enormous; future lawsuits will kill the technology, especially in the litigious United States. I'm convinced this is the reason for the sudden disappearance of Google Glass.)

Augmented and virtual reality experiments are not new. What's new is the realization that much of the horsepower and hardware necessary for these modern experiments can already be found in smartphone and tablet computers. Half of the work is done. It's just a matter of repurposing devices, which will result in lower costs. Google Cardboard shows just how low companies may be able to go and still deliver a compelling experience.

This is a classic example of an unintended consequence of the smartphone. The dedicated device—Google Glass, Oculus Rift, Microsoft HoloLens—might be missing the mark by not leveraging the technology that's freely available.

Everyone in the market for these products already has a phone and a tablet loaded with technology, including a fabulous display. Why reinvent the wheel?

A handwritten signature in black ink that reads "John Dvorak". The signature is fluid and cursive, with the first letters of each word being capitalized and prominent.

john_dvorak@pcmag.com

EDITOR-IN-CHIEF, PC MAGAZINE NETWORK Dan Costa

CREATIVE DIRECTOR, ZIFF DAVIS Cynthia Passanante

MANAGING EDITOR, DIGITAL EDITIONS Matthew Murray

SENIOR DESIGNER Jackie Smith

SENIOR PRODUCER Mark Lamorgese

NEWS & FEATURES

EXECUTIVE EDITOR Chloe Albanesius

FEATURES EDITORS Evan Dashevsky, Eric Griffith

SENIOR FEATURES WRITER Chandra Steele

NEWS REPORTERS Stephanie Mlot, Angela Moscaritolo

REVIEWS

EXECUTIVE EDITOR Wendy Sheehan Donnell

MANAGING EDITORS Sean Carroll (software, security), Alex Colon (consumer electronics, mobile), Laarni Almendrala Ragaza (hardware)

LEAD ANALYSTS Michael Muchmore (software), Neil J. Rubenking (security), Joel Santo Domingo (desktops, laptops), Sascha Segan (mobile), M. David Stone (printers, projectors, scanners)

SENIOR ANALYSTS Jim Fisher (digital cameras), Will Greenwald (consumer electronics), Jeffrey L. Wilson (software)

ANALYSTS Max Eddy (software, security), Tony Hoffman (printers, scanners), Ajay Kumar (mobile), Ben Radding (consumer electronics, hardware)

JUNIOR ANALYSTS Matthew Buzzi (hardware), Jordan Minor (software), Timothy Torres (consumer electronics)

INVENTORY CONTROL COORDINATOR KT Tandler

BUSINESS

EDITOR Oliver Rist

MANAGING EDITOR Suzanne Kattau

ASSISTANT EDITOR Rob Marvin

ART, MEDIA & PRODUCTION

DIRECTOR OF PRODUCT DEVELOPMENT Sal Cangeloso

PRODUCER Gina Latessa

COMMERCE PRODUCER Arielle Rochette

DESIGNER James Jacobsen

PRODUCTION DESIGNER José Ruiz

STAFF PHOTOGRAPHER Paul Maljak

SENIOR VIDEO PRODUCER Weston Almond

CONTRIBUTING EDITORS

Tim Bajarin, John R. Delaney, Jill Duffy, John C. Dvorak, William Fenton, Tim Gideon, Bill Howard, Edward Mendelson

**ZIFF DAVIS INC.**

CHIEF EXECUTIVE OFFICER Vivek Shah

CHIEF OPERATING OFFICER Steven Horowitz

CHIEF FINANCIAL OFFICER Brian Stewart

CHIEF TECHNOLOGY OFFICER Joey Fortuna

CHIEF STRATEGY OFFICER James Yaffe

SENIOR VICE PRESIDENT, SALES AND MARKETING Eric Koepele

SENIOR VICE PRESIDENT, BUSINESS DEVELOPMENT Anurag Harsh

SENIOR VICE PRESIDENT AND GENERAL MANAGER, DATA SOLUTIONS Bennett Zucker

SENIOR VICE PRESIDENT AND GENERAL MANAGER, ACCOUNTING Fredrick Rolff

SENIOR VICE PRESIDENT, CONTENT Dan Costa

GENERAL COUNSEL Stephen Hicks

VICE PRESIDENTS Frank Bilich (media sales), Lucas Deryckx (engineering), Melissa Hart (marketing), Michael Kane (product experience), James L'Heureux (ad and revenue operations), Diane Malanowski (human resources), Michael Pantoliano (business intelligence), Jennifer Riccio (FP&A), Archie Rosenblum (technology), Jason Steele (commerce), James Steven (operations), Marc Von Holzen (software development)

THE INDEPENDENT GUIDE *PC Magazine* is the Independent Guide to Technology. Our mission is to test and review computer- and Internet-related products and services and report fairly and objectively on the results. Our editors do not invest in firms whose products or services we review, nor do we accept travel tickets or other gifts of value from such firms. Except where noted, *PC Magazine* reviews are of products and services that are currently available. Our reviews are written without regard to advertising or business relationships with any vendor.

HOW TO CONTACT EDITORS We welcome comments from readers. Send your comments to pcmag@pcmag.com or to *PC Magazine*, 28 E. 28th St., New York, NY 10016-7940. Please include a daytime telephone number. *PC Magazine's* general number is 212-503-3500. We cannot look up stories from past issues, recommend products, or diagnose problems with your PC by phone.

PERMISSIONS, REPRINTS, CONTENT, AND TRADEMARK RIGHTS For permission to reuse material in this publication or to use our logo, contact us at Brand_Licensing@ziffdavis.com, or by phone at 212-503-5263/5264. Material in this publication may not be reproduced in any form without written permission. Copyright © 2015, Ziff Davis Inc. All rights reserved. Reproduction in whole or in part without permission is prohibited.