

KING'S QUEST

the OFFICIAL BOOK OF KING'S QUEST

DAVENTRY AND BEYOND

foreword
by
ROBERTA WILLIAMS

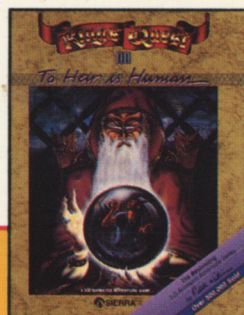
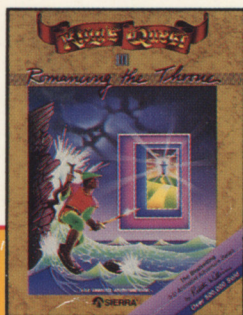
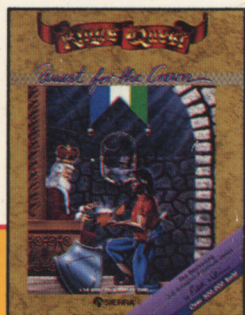

DONALD B. TRIVETTE

the
OFFICIAL
BOOK OF
KING'S
QUEST

DAVENTRY AND BEYOND

DONALD B. TRIVETTE

COMPUTE! Books

Greensboro, North Carolina
Radnor, Pennsylvania

Copyright 1988, COMPUTE! Books. All rights reserved.

Reproduction or translation of any part of this work beyond that permitted by Sections 107 and 108 of the United States Copyright Act without the permission of the copyright owner is unlawful.

Cover and interior design by:
Anthony Jacobson

ISBN 0-87455-155-2

Printed in the United States of America

10 9 8 7 6 5 4

Library of Congress Cataloging-in-Publication Data

Trivette, Donald B.,

The official book of King's quest : Daventry and beyond / Donald

B. Trivette.

p. cm.

Includes index.

ISBN 0-87455-155-2 :

1. King's Quest (Game) I. Title.

GV1469.25.K56T75 1988

794.8'4--dc19

88-23771

CIP

The author and publisher have made every effort in the preparation of this book to insure the accuracy of the programs and information. However, the information in this book is sold without warranty, either express or implied. Neither the author nor COMPUTE! Books will be liable for any damages caused or alleged to be caused directly, indirectly, incidentally, or consequentially by the programs or information in this book.

The opinions expressed in this book are solely those of the author and are not necessarily those of COMPUTE! Books.

COMPUTE! Books, 324 West Wendover Ave., Greensboro, NC 27403, (919) 275-9809, is a Capital Cities/ABC Company, and is not associated with any manufacturer of personal computers.

The following are registered trademarks or service marks:

Amiga, of Commodore-Amiga, Inc.; Apple, of Apple Computer, Inc.; Apple IIc, of Apple Computer, Inc.; Apple IIe, of Apple Computer, Inc.; Apple IIIGS, of Apple Computer, Inc.; Atari ST, of Atari Corp.; Clue, of Parker Brothers, Inc.; CompuServe, of CompuServe Information Services Corp.; Famous Amos, of Famous Amos Cookies, Inc.; IBM, of International Business Machines, Inc.; IBM PC, of International Business Machines, Inc.; IBM PS/2, of International Business Machines, Inc.; King's Quest, of Sierra On-Line, Inc.; Kraft Premium III, of Kraft Systems, Inc.; Macintosh, of Apple Computer, Inc.; Macintosh II, of Apple Computer, Inc.; Sierra, of Sierra On-Line, Inc.; Tandy, of Tandy Corp.; TRS/80, of Tandy Corp..

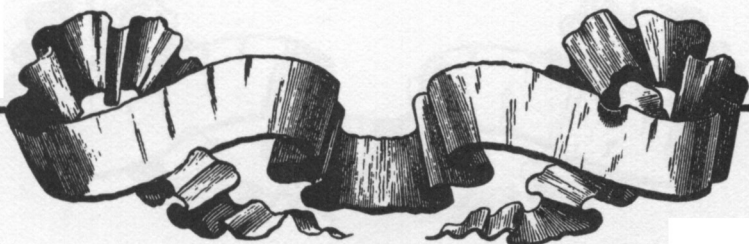

**For my Mother,
Who can solve any puzzle.**



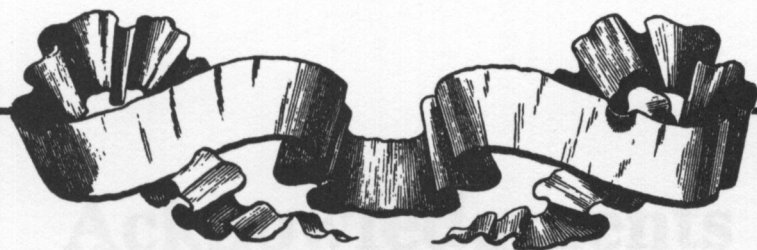

Contents

Acknowledgements	vii
Foreword by Roberta Williams	ix
Introduction	xi

Part I

1. Sierra: The Real-Life Adventure	3
2. The Making of <i>King's Quest IV</i>	11
3. The Mechanics of Questing	27

Part II

4. <i>King's Quest I: Quest for the Crown</i>	39
5. <i>King's Quest II: Romancing the Throne</i>	53
6. <i>King's Quest III: To Heir is Human</i>	69
7. <i>King's Quest IV: The Perils of Rosella</i>	89
8. <i>King's Quest V: ?</i>	105

Appendices

A. Master Crossword Puzzle for <i>King's Quest I-IV</i>	111
B. Pronunciation Guide to the Characters and Places of the Quests	113
C. Score Values	115
D. Most-Asked Questions	123
Index	127

Acknowledgments



here are quite a few people at Sierra On-Line who took the time to help me with this book. Chief among them are John Williams, Paul DePlege, and Jerry Albright who spent many hours collecting information and photographs; Ken Koch, Jerry Moore, Chane Fullmer, John Hamilton, and Sol Ackerman who explained the complexities of their crafts; and, of course, the sorceress herself, Roberta Williams. Without their help I would have surely been lost in the woods of Davenport and mired in the swamps of Tamir.



I also thank Wisco Computing of Wisconsin Rapids, Wisconsin, for *Crossword Power*, the software that generated the puzzles you'll love to hate; and Kraft Systems, Inc. for the joystick that makes climbing circular stairs a breeze.

Roberta Anne Williams
Oakhurst, California
May 1987

Foreword



As a child I was always filled with story ideas and loved to pretend. Of course, I was always the heroine of my private daydreams; I was forever slaying dragons, outwitting pirates, traveling through time, and yes, looking for—and sometimes finding—Prince Charming. King's Quest is filled with the adventures I daydreamed of as a child. Through the technical wizardry of people like Jeff Stephensen and Bob Heitman, and my husband, I am able to share my world with all of you.

One of the reasons for King's Quest's popularity is that it *does* spring from the fantasies of a child. For adults, it allows them to experience again the stories and fables they loved as children. For children, it's the ultimate cartoon—a cartoon they can participate in. And for both, it is a chance to try to outwit the designer... me.

This book will give you a greater understanding of what King's Quest is and how it came about. You will come to know how much work is involved in bringing each game to life. Sometimes I get frustrated when I can't think of an idea, or when we can't make something work, or when we're working long hours to make a shipping date. But the wonderful letters I receive from kids, parents, and even grandparents makes it all more than worthwhile.

In real life, I did find my prince: my husband, Ken Williams. Ken has always supported and encouraged me, and without him, King's Quest would surely not exist.

Roberta Heuer Williams
Oakhurst, California
May 1988

Introduction



first came across *King's Quest* when I was writing a monthly column for *COMPUTE!* magazine. Never a great fan of arcade games and disappointed by the flat, map-like characteristics of adventure games in those days, I was overwhelmed and delighted by the three-dimensional cartoon quality of *King's Quest*. So were hundreds of thousands of you.

The games did well and I wrote about them in several issues. Every time I did, I got piles of letters asking for clues. Some were written in crayon on notebook paper and others were typed on fine stationery. *King's Questers* are all ages: A grandfather wanted to know the Gnome's name (the biggest mystery in the saga) so he could impress his grandchildren; a six year old wanted to know how to get the lady fish to show up; and a wife wanted to give the Gnome's name to her husband as a birthday gift!

These games are not easy. When you pay \$30 to \$50 for entertainment, the people at Sierra think you deserve more than a few hours of fun and challenge. (All versions of *King's Quest* list for \$49.95, but mailorder is less expensive.) It may take you several weeks to solve a quest. Even if you know the answers beforehand and have the programmers' maps (as I did when working on this book) it still takes many hours to complete a quest.

The Official Book of King's Quest is divided into two parts. Part one is for those who have played one or more *King's Quest* games and want to know how they came about, how they are developed and programmed, and some of the secret commands never before published. You'll find photographs of *King's Quest IV* under construction, program listings, and some of the debugging commands used by the Sierra programmers. You may even be able to use some of these privileged commands on your own computer.

Part two is for anyone who needs a little help completing a quest. There are clues and maps, but few direct answers. You

will find some specific answers in the crossword puzzles – I rationalize that that isn't giving away too much, because you still must solve something to get an answer.

I challenge you to refer as little as possible to the clues. I solved the first three quests without assistance, and only a tight publishing deadline caused me to use the programmers' notes on *King's Quest IV*. Incidentally, I never did figure out the Gnome's name by myself, but you don't have to know it to complete *King's Quest I*.

All the King's Quest games draw characters and plots from nursery rhymes, classic mythology, and fables of old. If your childhood is well grounded in Mother Goose, you will have an inside track on solving them.

You may, of course, play the King's Quest games in any order; each is a great adventure game in its own right, but true questers will follow the saga. In a nutshell, here are the four King's Quest stories:

- † A dashing young knight named Graham must find three magic treasures—a chest, a mirror, and a shield—that old King Edward has let slip from the Kingdom of Daventry; Graham succeeds and becomes King Graham on Edward's death.
- † King Graham falls in love with a mysterious maiden named Valanice who is imprisoned in a tower in the Land of Kolyma. After overcoming many obstacles, he rescues her and they are married.
- † A boy named Gwydion is held captive in Llewddor by a wicked wizard; he must escape to learn his true identity. When he does, he rescues his twin sister Rosella who is in Daventry in the clutches of a dragon. That done, Gwydion and Rosella are reunited with their parents, King Graham and Queen Valanice.
- † This time it's Rosella who goes on the quest. She's after an enchanted fruit that will restore her aging father's health after a heart attack, but along the way she must do the bidding of an evil fairy.

Happy Questing.

Part One



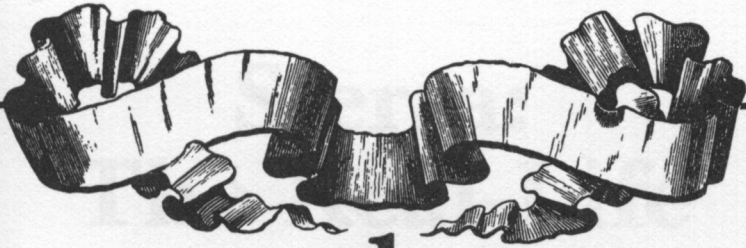

**SIERRA:
the
REAL-LIFE
ADVENTURE**

Sierra: The Real-Life Adventure



Not too long ago there lived in the City of Los Angeles a young couple. The man was named Ken and the woman, Roberta. To amuse herself, Roberta played adventure games while Ken was at the office writing accounting programs for major corporations. And that's how a real-life adventure begins.

In the late 1970s, a computer adventure game did not have pictures or drawings, but consisted only of words. The player would read a paragraph and enter a one- or two-word response. One of the very first adventure games, called *Colossal Cave*, was written at the Massachusetts Institute of Technology and found its way into mainframe computers around the country. In about 1979 a variation of *Colossal Cave* was published by Microsoft as *Microsoft's Original Adventure* and by Apple as *Apple's Original Adventure*.

A typical *Colossal Cave* scenario might have several paragraphs of text describing in detail what you were "seeing." For example, "You are walking down a long dark passage with cold water dripping from the stone walls. Ahead you see an ugly troll carrying an ax; he is coming toward you." Perhaps you respond to this inconvenience by typing: "Take Ax." *Colossal Cave* might then reply: "Too bad, the nasty troll swung the ax and hit you in the head. You are now dead." Everything was done with words; there were no pictures.

• The First Graphic Adventure •



In 1980 Roberta and Ken Williams decided to develop something more exciting. The project was conceived as a hobby or family project like converting the basement into a rec room or planting a vegetable garden, but soon it took on a life of its own. With Roberta working on the story line and Ken doing the programming, the first graphic adventure game was born on their kitchen table. It was called *Mystery House*, and featured black and white pictures along with text.

Mystery House was a combination of an Agatha Christie novel and the parlor game *Clue*. You find yourself in an abandoned Victorian house with seven other people. Your challenge is to find a treasure of jewels. As you explore the house, you keep stumbling over the bodies of your fellow explorers. In order to complete the game, you must also discover the murderer.

Mystery House had pictures along with the text. You did not see the main character, as you do in *King's Quest*. Instead, you saw the rooms from the character's perspective: a first-person view. The pictures were black and white, and the commands were still limited to one or two words; nevertheless, *Mystery House* was so unusual that Ken and Roberta placed a small ad in *Micro* magazine. For \$24.95, the ad promised, you could buy a copy of *Mystery House* to run on your Apple II.

• Sierra On-Line •



This was in the days before IBM introduced the PC, and few people had any idea how widespread personal computing would become. The Apple and the TRS/80 were about the only personal computers around. To everyone's amazement *Mystery House* eventually sold over 10,000 copies. The company expanded from the kitchen table to the den and spare bedroom. A few months later Ken and Roberta decided that if they were going to run a "garage industry" they could at least locate the garage in a pleasant place. They moved from Los Angeles to Coarsegold, California, not far from Yosemite National Park. Sierra On-Line was born.

At first Sierra continued to operate from the Williams' home, but when space became inadequate, the company moved to a real office over a print shop. Later it expanded into several other buildings.

Soon three new adventure games were climbing the best-seller's chart: *The Wizard and the Princess*, *Mission: Asteroid*, and *Time Zone*. The first was about a beautiful princess who needed saving from an evil wizard; the second featured an asteroid headed toward earth; and the third was the popular *Time Zone*, in which you were allowed to travel back in time and make changes to history. *Time Zone*, with more than 1,300 screens, required six double-sided Apple disks and still holds the record as Sierra's largest adventure game. Although these games were in color, there was no animation and commands were limited to two words.

A year before the IBM PCjr was announced (when the "Peanut" was just a rumor to the rest of us) IBM asked Sierra to create a game that would show off the new computer's color-graphics capabilities. IBM supplied the company with a prototype Junior, and Roberta set to work designing a new type of adventure game. Eighteen months and \$700,000 later, she and a team of six programmers completed the task.

King's Quest was the first three-dimensional animated adventure game. The main character, Sir Graham, looked and moved like a cartoon figure. He could walk from scene to scene, disappear behind trees, swim lakes, and enter buildings. King's Quest was a phenomenal success, partly because of its stunning graphics and partly because of its creative and unusual story line.

In the tradition of Hollywood, *King's Quest II* followed in May 1985; and *King's Quest III* was released in October 1986. Each is more detailed and sophisticated than its predecessor. Originally developed for the IBM family of computers, *King's Quests I* through *III* are now available for Apple, Amiga, Atari, Macintosh, and Gandy machines.

King's Quest IV



he newest member of the saga, *King's Quest IV: The Perils of Rosella*, was released in September, 1988. It's the result of Sierra's completely new adventure development software which produces more complex games and stunning high-resolution graphics.

Today, Sierra On-Line is a thriving business employing more than one hundred people with a wide range of interests and talents. Most of the creative inspiration still comes from Roberta; Ken oversees the corporate finances, planning, and production. The Sierra family includes professional artists, musicians, and programmers as well as public relations representatives, marketing people, and a large customer-service staff.

The company recently moved into a new building located on the outskirts of Oakhurst, California. The building, modular in construction and easy to expand, is located in a park-like setting with skiing in winter and canoeing, swimming, and fishing in nearby Bass Lake.

Sierra's headquarters has an elaborate security system that would do justice to a military installation or an adventure game. It protects the company's products, secrets, and the equipment lent to it by major hardware firms like IBM and Apple. Sierra frequently works with developmental models of computers that haven't been announced. There are three large vaults where hardware can be securely stored, and the entire building is divided into security zones. You must enter the appropriate code to pass from one zone to another.

In addition to business offices and a warehouse, the new headquarters has a music studio, several art studios, and a facility to develop interactive CD-ROM, which promises to be the media of the next generation in adventure games. The entire building is wired for a computer network of more than one hundred nodes.

Roberta and Ken no longer live in the Coarsegold house; it burned in 1982. The Williams and their two children, D.J. and Chris, now ramble around in a natural, cedar clad home overlooking a lake. The house has a large computer room for the family's seven computers. Both sons show signs of carrying on the family tradition: D.J. enjoys producing computer sound effects, and nine-year old Chris does animation with the King's Quest development tools.

the
MAKING
OF
KING'S
QUEST IV

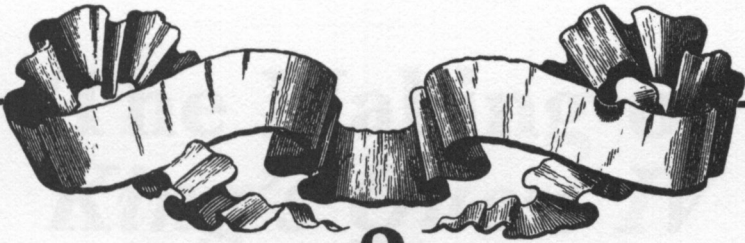

2

the
MAKING
OF
KING'S
QUEST IV

The Making of *King's Quest IV*



King's Quest IV, like the other Quests in the saga, began as an idea in Roberta Williams' head. This time she wanted the main character to be a woman, so Princess Rosella, the sister of Gwydion from *King's Quest III*, was given the title role. Rosella's quest is to find a magic fruit that will restore her father, King Graham of *Quest I* and *II*, to health.

First Roberta outlines the story on scraps of paper and in notebooks, making changes freely as the plot thickens. Sometimes she consults her two children, D.J. and Chris, but husband Ken is little help; he's more interested in the technical details than the story line. As the story begins to gel, Roberta makes rough drawings of each scene, called *rooms* by the developers. For example, the original sketch of the fisherman's shack, room 7, showed a boxy house with a line extending out to represent the pier.

Roberta also writes a description of each room; here's what she says about room 7:

A beach. Ocean to the west. Beach turning to green grass to the east. A fisherman's shack overlooks the ocean with maybe a little pier or something going into the water.

In addition to the drawing and the description, Roberta creates the script or story line that explains what goes on in each room. Although this gives away a few clues, here's what she says about the fisherman's shack:

1. You need to go to room 7 and enter the fisherman's house, room 42. There will be a fishing pole in there leaning against the wall. You want to get the fishing pole but to do that you need to buy it. The fisherman and his wife will take the pouch of diamonds in

trade for the fishing pole. But, they will also take the golden ball. You don't want to give them that, though, because you need it for the frog. It's not possible to give them the hen that lays the golden eggs because you can't get the hen until AFTER getting the unicorn.

2. Next, you can go into any of the beach rooms and "fish." Randomly you can catch a fish. Keep the fish with you. (Maybe you can only fish from the pier, for animation reasons.)

Of course some things change as the game develops. To conserve memory, it was decided that you *could* only fish from the end of the pier. And to avoid confusion, the fisherman and his wife will take nothing but diamonds in exchange for the fishing pole.

Setting the Stage



From Roberta's sketches and written material, the artists and programmers begin to construct the game using special programming tools developed by Sierra. View Editor is the program used to draw animated objects like Rosella and the fisherman. The central character, Rosella in this game, is always called Ego by the programmers and artists no matter what his or her gender in the program.

Picture Editor is the program used to construct and draw the background scenes like the fisherman's shack and pier. When the background artist got Roberta's sketch of the fisherman's shack, he first drew an outline of the building and pier. Next, he colored in large surfaces, then added textures and details like flowers, roof shingles, and wood grains. All King's Quest rooms use shade and shadow as well as perspective to give the illusion of three dimensions. In the photographs (see color section) notice how the roof line slants to a vanishing point far to the right of the screen. Vanishing points are chosen to be high on the horizon to give the characters as much space as possible to walk; a low vanishing point would limit Ego's range.

Backgrounds are not stored as a completed picture; instead, they're constructed and stored as coordinates and vectors. Vectors give the instructions for drawing a picture, and they have the advantage of taking less space than would a bit image of a complete picture. The artist works with a standard IBM PC and mouse, using pull down menus and windows similar to many commercial CAD programs.

To maintain and enhance the three dimensional quality of the rooms, every object is constructed with a priority in relation to the other objects. There are 16 bands or areas in which things may be placed. Although the priority bands are invisible in the finished product, the artist must use them like a horizontal grid as he draws the room. Considerable effort and time is spent placing houses, bushes, and trees so the player remains unaware of the room's mathematical rigidity. It wouldn't do for things to look like they were lined up on a checker board.

As the room nears completion the artist adds control lines that determine where Ego can walk. She *shouldn't* walk through a wall or tree, for example, but sometimes she does. If a tree is placed between two priority bands, Ego will walk right through it. The Sierra staff spends a lot of time running Ego all over the rooms looking for places where she falls off or walks through something she shouldn't. Fixing an error may involve shifting a tree to a priority band or adding new features to a room to cover up a programming bug. In the fisherman's shack room, for example, a rope fence was added to keep Ego from falling off the pier onto the sandy beach.

• Creating the Characters •



Another artist is responsible for drawing the animated characters. Although the backgrounds are vector graphics (lines), the characters like Ego and the fisherman are made up of pixel drawings. The fisherman, for example, is created in a box about 33 squares high and 16 to 18 squares wide. By changing the colors of the squares, the character takes on different shapes, activities, and appears to move. The background color is special. This invisible-color

color takes on whatever color is behind it in the room. Thus, as Ego walks by a tree, you see brown bark surrounding her arm. The invisible color varies from room to room, but it's always a hue different from everything else in the room.

Animation is achieved by rapidly displaying several of these drawings or cells one after the other, similar to a flip book. It takes eight cells for the fisherman to take one step to the right, and eight more cells for one step to the left. A step up or a step down requires a cycle of six cells each. Thus, 28 separate drawings are required for the fisherman to walk. Because he sometimes carries a fishing pole, another 28 drawings are needed. He needs six cells to eat, six more to talk, and eight cells to get up off the pier. In all, the fisherman needs 76 drawings for his animation. Ego herself requires more than one thousand drawings to animate all her activities.

A room may take several days to draw, and then additional time is spent debugging and cleaning up. If the room takes too much memory (the average is about 12,000 to 14,000 bytes) it will load slowly and waste space. As part of the clean up, the artist looks for places to economize. The fisherman's shack takes 12,700 bytes and, as this is written, there is debate about the best way to draw the waves. Continuous waves will take considerable memory, so when you get to this room you may find the roaring surf reduced to an occasional swell.

• Script Interpreter •



he programmer is the one who puts all the rooms and animated characters together to make the game run. He does this using a special computer language called SCI (S**CR**ipt **I**nterpreter) developed by Sierra. SCI is an object-oriented language similar to LISP; it's written in Assembler, C, and itself. An older version of the interpreter, called Adventure Game Interpreter (AGI), was used to create *King's Quests I, II, and III* and the 256K version of *King's Quest IV*.

With SCI the programmer establishes classes of objects. The Actor Class, for example, includes anything that moves such as sea gulls, ogres, and Ego. The Props Class is composed of items that move but don't go anywhere—like a candle flame or smoke. The Views Class is for things that don't require any animation, like the fisherman's fishing rod. The programmer writes scripts in the SCI language that define how the objects come together and interact with one another.

In room 7, a fairly simple room by *King's Quest IV* standards, there are six things to animate: smoke, sea gulls, waves, the door, the fisherman, and Ego.

A repeating cycle of four drawings gives the illusion of smoke coming from the fisherman's chimney. The *work = 3* statement causes the smoke to move at one-third full speed. The instructions to make the smoke are:

```
animate.obj( smoke);
ignore.horizon( smoke);
set.view( smoke, v.fish.cabin);
set.loop( smoke, 1);
ignore.blocks( smoke);
position( smoke, 95, 16);
work = 3;
step.time( smoke, work);
cycle.time( smoke, work);
draw( smoke);
```

Opening and closing the door to the house is considerably more complicated. This requires activating a five-drawing sequence which is triggered by the following code:

```
if (said( open, door)) [ must be close enough
  {if (posn( ego, 86, 120, 106, 133))
    {if (!night)
      {if ( door.open)
        {print("The door is already open... )
        else {set( game.control);
              set.priority( ego, 11);
              start.update( door);
              end.of.loop( door, door.done);
            }
        else {print("You can't -- it's locked...)}
        else {set( notCloseEnough);
              }
      }
    }
  if (said( unlock, door)) [ must be close enough
    {if (posn( ego, 86, 120, 106, 133))
      {if (!night)
```

```

        {print("The door is already unlocked...}
    else {print("You can't, it's locked... }}
    else {set( notCloseEnough); }
if ((said( knock, at, door) || [ must be close enough
    said( knock
    said( knock, on, door) ||
    said( knock, door)))
    {if (posn( ego, 86, 120, 106, 133))
        {if (!night)
            {print("You knock on the door...
                a woman says... )
                else {print "You knock on the...
                    a man calls out...}}
        else {set( notCloseEnough);
    }}

```

In English this says: If you try to unlock the door the program will say, *The door is already unlocked*. If you knock on the door—the polite way to enter a home—the fisherman’s wife will invite you in and you can open the door. At that point the program will begin the animation to open the door. If you’re not within range of the door, the program will tell you that you’re not near enough. If you should come to the house at night, a whole different set of instructions apply (the fisherman will say it’s too late).

The sea gulls require a good bit of code to fly about in room 7. Their number (from 1 to 3) is randomly determined and their actions are governed by a built-in Wander function. The sea gulls’ bounds are limited by control lines and priorities. There’s a control line just above the horizon, so the birds won’t wander into the ground, and their priority is set to 0 so they will always appear to fly behind the house.

A *function* is a set of generic instructions that can be used over and over to do the same operation on different sets of data. The BASIC language, for example, has a square root function that calculates the square root of a number; spreadsheets have an average function to find the average of a column of numbers; and SCI has many functions to speed up programming, including Wander, Chase, and Moveto.

Chase is a tricky bit of programming; it takes a lot of instructions to assure that Ego gets chased properly. At all times the Chase function knows her coordinates as well as those of the chaser. When Ego moves around a rock or tree, the Chase function must compute a path for the chaser—perhaps an Ogre or Wizard—to follow.

If Ego gets caught, there is no Death function to kick in and automatically take care of the details. Each death scene gets individual animation and attention; there's no standard way for her to die. Incidentally, Ego can't die in room 7 (there's no animation for that to happen); if she falls into the water, she will automatically swim.

There *is* animation in room 7 in case she falls off the pier. In fact, there are several scripts for that event. One if she falls off the north side, and another if she falls off the south side. If she falls south, for example, that triggers instructions called EgoShortFall and EgoShortSplash. A similar code provides for a fall to the north, but without the splash loop since a splash would be hidden by the pier.

There is no script if Ego should happen to fall off the pier onto the beach, so the artists added the rope fence to prevent that from happening. Think how silly she would look splashing around on dry land.

Ego can also fall on the rocks—called the fallRocks Script; this triggers an EgoStunned routine for three seconds. Here's how those instructions look:

```
[*****
[fallROCKS
[*****
if (hit.special)
  (if ((rf2 || rf3 || rf4))
    (reset(hit.special);
     get.pasn(ego, priorx, priory);
     position.f(dude, priorx, priory);
     ignore.blocks(dude);
     set( game.control);
     set.view( dude, v.ego.land);
     if ((ego.dir == 3 || ego.dir == 4))
       { set.loop( dude, 2); }
     else
       { set.loop( dude,3); }
     fix.loop(dude);
     work = 3;
     step.size( dude, work);
     work = 3;
     cycle.time( dude, work);
     start.cycling(dude);
     erase(ego);
     draw(dude);
     if (rf3)
       {work6=0;
        move.obj.f( dude, tempx, tempy, work6, fall.done);
       }
  )
)
```

```

if (rf4)
{
work6=0;
move.obj.f( dude, tempx, tempy, work6, fall.done);
}
if (rf2)
{if (priority < 125)}
set.priority(dude, 9);
tempy=132;
work6=0;
move.obj.f( dude, ego.x, tempy, work6, fall.done);
}
else {
set.priority(dude, 15);
tempy=156;
work6=0;
move.obj.f( dude, ego.x, tempy, work6, fall.done);
}})

```

Control is taken away from the user as the fall begins and is returned when the fall sequence is complete. In other words, you can't use the joystick or keyboard while Ego is falling or stunned.

Room 7 is an average *King's Quest IV* room, yet it takes more than 600 lines of instructions to describe how things happen there. A programmer spent two days writing room 7 code, and the cleanup programmer spent more time improving and correcting the code. *King's Quest IV* distinguishes between day and night, so there are about 30 rooms that have moonlight versions of the daylight rooms. The entire *King's Quest IV* game contains more than 140 rooms and tens of thousands of lines of instructions.

♫ Music ♫



Although *King's Quest I-III* have music and sound effects, the quality of the music hadn't kept pace with the improvements in graphics and animation. Roberta was determined to change that, so in addition to artists and programmers, *King's Quest IV* also had the talents of a professional musician. Once the game was playable, a tour of the quest was recorded on video tape and sent to William Goldstein for musical scoring.

Goldstein has several Hollywood films to his credit including Touchstone's recent *Hello Again*, as well as the television version of *Fame*, for which he received an Emmy nomination. His electronic music compositions include *Ocean Scape* on the CBS label and *Switched on Classics* for the Proarte label.

For *King's Quest IV* Goldstein chose to work with a Roland MT-32 synthesizer, which is actually eight synthesizers in one. With its capability to simulate 32 voices or instruments at the same time, the Roland MT-32 is like having a small orchestra in your computer. The stereo synthesizer can add rich and subtle ambiences to a musical composition. Goldstein used a slight echo in each of the interior rooms, for example, to give an illusion of depth and space.

There are more than 75 pieces of music in *King's Quest IV*, which is more than in a feature-length film. The compositions include a sinister wedding march, organ music, Middle Eastern music to charm a cobra, and five selections for a wandering minstrel, who plays so badly that you'll laugh at his rendition of *Greensleeves*. There's an elaborate eight and a half-minute piece to accompany the animated introduction where the old King is taken ill and Rosella learns of her quest. This is mood music to set the tone and emotion for *King's Quest IV*. In addition, each of the 35 characters in the game has his or her own theme songs.

Although room 7 doesn't have any music, the fisherman has an introductory tune when he meets Rosella on the end of the pier. Roberta Williams suggested several adjectives that describe the fisherman's character: "old, sea salt, poor, despairing" and Goldstein composed a suitably salty eight-second chanty.

To get the full stereophonic, orchestral effect of the music, you'll have to install an optional music card in your computer. For IBM computers, *King's Quest IV* supports three cards: the AdLib music card, the IBM music card, and the Roland MT-32. They range in price from \$245 to \$600. The music cards must be connected to the amplifier and speakers in your existing stereo system.

For computers without enhanced music capabilities, Goldstein's soundtrack was distilled into a form that uses the limited capability of the standard IBM PC. The Apple and Tandy versions of *King's Quest IV* have better sound than the standard IBM version, because those machines have better sound hardware.

The striking composition of William Goldstein and the "live-performance" sound of a music card contribute a new dimension to *King's Quest IV*. You've got to hear it to appreciate how much of a difference professional music makes in a computer game.

• Quality Control •



nce the game is thought to be finished, it goes to the Sierra Quality Assurance department along with the story line and the programmers' maps. One of the first things QA does is to extract from the software all the text and messages—things like, YOU CAN'T DO THAT and ROSELLA SEES A BEAUTIFUL FAIRY.... This results in a small book, which is then proofread for grammar, spelling, and punctuation by one of the five quality-assurance people.

The QA staff begins playing the game using the programmers' maps and notes. Even with this help, it takes at least two eight-hour days for them to complete the quest. The testers are looking for inconsistencies: places where Ego is visible through a tree, where she can't leave a room, where she is carrying the wrong object. Errors are reported to the programmers, who decide whether they are valid errors. In *King's Quest III*, for example, when the wizard demands a meal, Ego must leave the dining room and then reenter in order for the wizard to sit at the table and eat. The QA people thought this was an error, the programmers said it wasn't. So if you put food on the table, but the Wiz won't sit down, try leaving and returning.

The QA staff also makes esthetic suggestions. They felt the antlers in the dining room in the Apple version of *King's Quest III* were the wrong color. The color was changed. Another color problem in the same game was not so easily resolved. There is a spider that gets carried out over the ocean and dropped into the

water (if he doesn't get Ego first). The spider and the ocean were the same color. The QA people, the programmers, and the artists had a meeting to discuss the problem of the invisible spider. Unfortunately, all the alternate colors were also in use and just caused the spider to disappear somewhere else. This colorful matter was bucked to the top: Roberta decided the spider and the ocean would remain the same color and the spider's splash was enhanced.

The Quality Assurance Department uses more than 30 different computers in the most popular configurations to test each Sierra product. About half of the machines are MS-DOS clones and compatibles, the others are Macintoshes, Apples, Amigas, and Ataris. After four to eight weeks, hundreds of man and woman hours, and 20 to 30 error-correcting cycles, the product is deemed ready to ship. Even with all this careful testing, the QA staff knows a few of us will try something or do something the designers and testers did not anticipate. There are usually a small number of follow-up bugs to exterminate.

• Debugging Tools •



he more complete a King's Quest becomes, the more difficult it is to test and debug. Can you imagine wanting to check out something in Dracula's Castle, for example, and having to play the game to get to that point? Obviously programmers don't want to waste time collecting the items necessary to cross the Poisoned Lake, so special software is attached to the game to make checking and correcting easy. This is called *debugging software*.

Here's something few people know: The debugging software remains part of some versions of King's Quest on the store shelves. *King's Quest IV*, because of the amount of memory the debug routines require, is probably going to be an exception.

Now for an important disclaimer:

Sierra On-Line Customer service doesn't have documentation on these commands and they can't answer questions about them or how to use them. They may deny the commands exist. You can't use these commands in actual play. Strange things can and will happen: Sometimes the computer will freeze or terminate the game. Use these commands at your own risk.

With that said, here are some of the special commands I've found for *King's Quest I*. Some versions of *King's Quest II* and *III* have similar, but not identical debug routines. I've tested debug on the IBM PC; it also works, I'm told, on Atari, Amiga, and the Macintosh. The Apple version of *King's Quest I* does not have the debug software, but the Apple version of *King's Quest II* does.

Debug Mode



With Ego in any room, hold the Alt key and press the D key. The Alt-D combination causes the version number to appear on your screen; press the Enter key again and you'll get another message; press the Enter key a third time and you'll return to the prompt at the bottom of the screen. The difference is that you have also enabled the debug mode for the room you are in, although there is no evidence of that. (On the Macintosh use the Open-Apple key and the D key; on the Amiga and Atari, use Control-D.)

First try teleportation. Go through the Alt-D routine; you have to do that whenever you enter a room, and then, at the bottom of the screen, type TP and Enter. The computer will respond with WHAT ROOM:. Enter a room number and Ego will be instantly transported there. This is known to the programmers as the ZAP command. A few words of caution: Ego will materialize in the new room at the same location he was in the last room, which may leave him walking in air. Or you may zap him right into a raging river or a deep canyon. You will also zap anything that is with him to the new location. Wait until you see Ego

with a goat in the well. In my version, when Ego goes to a new room, he is trapped in the priority bands of the old room, so he often walks through walls and trees.

Without the programmers' maps, picking room numbers is more guess than science. Generally the numbers follow a pattern, but I'll leave discovering the pattern to you. Here's what I've located in *King's Quest I*: The first scene, outside the castle, is room 1; the woodcutter's house is room 44; selecting room 25 puts you at the troll bridge; the well is room 12. Teleport to room 51 and you'll have a dragon breathing fire down your neck; room 60 is in the clouds and room 73 is underground.

If you use a more conventional method to enter a room, you can query the debug program about where you are. Once you enter the Alt-D sequence, type SHOW VAR and press Enter; then press Enter again.

To look at the priority bands, press the F6 key on MS-DOS computers; priority bands can't be displayed on Apple computers.

To get an object, type GET OBJECT, Enter. Then enter the object number. Here are some I've worked out:

Code number	Object
1	Dagger
9	Bowl
18	Cheese
20	Egg
24	Mushroom

Have fun, but remember these are unofficial commands and shouldn't be used to complete the quest.



Although many people are involved in designing, programming, drawing, scoring, testing, and marketing a King's Quest, Roberta Williams is never far from the action. She is constantly looking for ways to improve her games and no facet is too small to escape her attention: Sometimes it's a bush in the wrong place, or a house that needs more color, or a dungeon that isn't gloomy enough. That attention to detail is one reason King's Quests are so much fun to play.

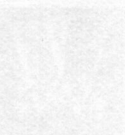

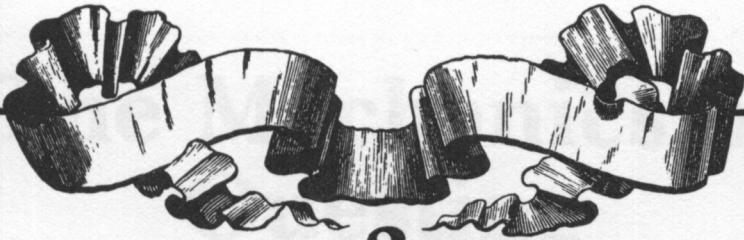

3

**the
MECHANICS
OF
QUESTING**

The Mechanics of Questing



King's Quest comes in different versions for different computers. Table 3-1, following, shows which software runs on what machines. Once you've identified the version you need, be sure to compare your machine's configuration and resources (memory, monitor type, and disk drive) with the requirements printed on the King's Quest box.

The different Apple versions of King's Quest cause some confusion with buyers. The Apple IIc/IIe version makes its 16 colors by dithering, a process of mixing several colors. Although this software runs on the Apple IIGS computer, a different version has been written especially to take advantage of the GS's true colors and faster speed. If you have an Apple IIGS, be sure to purchase the GS version.

The original Macintosh is a black and white computer so the original Macintosh King's Quest lacks color. The new Macintosh, however, has splendid colors and Sierra has an updated version to show them off. The new versions of King's Quest run in black and white on older Macs and in color on the Mac II; look for the word *color* on the package.

King's Quest IV comes in two MS/DOS versions. One is for computers with 256K of memory; a second version, with stunningly detailed graphics, is available for computers with 384K of memory. If you have the memory, be sure to get the larger version.

Table 3-1. King's Quest Versions

	KQ I	KQ II	KQ III	KQ IV
Amiga	yes	yes	yes	yes
Apple IIc/e	yes	yes	yes	no
Apple IIGS	yes	yes	yes	no
Atari ST	yes	yes	yes	yes
Commodore	no	no	no	no
Macintosh (512K)	yes	yes	yes	yes
Macintosh II	1	1	1	1
MS-DOS	yes	yes	yes	2
IBM-DOS	yes	yes	yes	2
Tandy	yes	yes	yes	2

(1) A new version that supports color graphics of the Macintosh II.

(2) Two MS-DOS versions: one for computers with 256K of memory, and a second version for machines with 384K of memory.

Display Differences On MS/DOS Computers



here are a variety of displays and adapters for IBM and IBM-compatible computers. Although King's Quest works with most of them, the results can be disappointing if you don't understand the limitations of your hardware.

King's Quest software can use the older color/graphics adapter (CGA), the more recent enhanced graphics adapter (EGA), the multi-color graphics adapter (MCGA), and the variable graphics adapter (VGA) found on IBM's PS/2 line of computers. The game also works on the Hercules Graphics adapter. It does not operate with the IBM monochrome display, which is not capable of showing graphics. The quality and resolution of the images produced by King's Quest on your computer depends entirely on the graphics adapter and monitor you are using.

The photographs in this book were taken from an IBM computer with an EGA 16-color display. If you have an EGA, VGA, or MCGA adapter, your screens will look similar. If your computer has the older CGA adapter, however, you will get only four colors. The Hercules adapter displays only shades of gray.

On four-color CGA computers, it's difficult to distinguish some objects and a little detail is lost. The game is not as much fun to play. But you don't have to buy a completely new computer to improve your graphics; even old models of the IBM PC can be upgraded either to EGA or VGA quality. You'll be surprised what a difference it makes.

• Installing King's Quest •



efore you can begin playing King's Quest you must initialize the software to work on your computer. These are *not* games you can put into a disk drive and then turn the computer on; they are not "boot-ready" disks.

To install the software, follow the instructions in the documentation. What you do depends on the brand of computer and size disk drives you have. King's Quest may be played from 5 1/4-inch, 3 1/2-inch, or a hard disk. Both sizes of floppy media are included with the MS/DOS version. There are detailed instructions in each package on how to install the program for your computer. Generally, you make a working or backup copy of the program, and use that to play the game. All King's Quest programs are copy-protected, so you'll have to have the original disk to insert as a key when you first start the program. The copy protection scheme can occasionally cause problems, particularly with unusual brand computers and unusual disk configurations.

Once the program is properly installed, either on a hard disk or a floppy, you simply type SIERRA (don't use quotes or other marks) and press the Enter key.

If yours is a floppy-based computer, remember to format and initialize a disk so you can save games in progress. You must do this in advance. Hard disk users may wait until they are ready to save a game before making a subdirectory.

• HELP! •



he popularity of King's Quest and other Sierra products means there is a lot of customer support for players.

If you have difficulty installing or running a King's Quest program, call Sierra Customer Service Monday–Friday between the hours of 8:00 a.m. and 5:00 p.m. Pacific Standard Time (11:00 a.m.–8:00 p.m. EST). The telephone number is (209) 683-6858. There are ten representatives on duty to help you. Have your box, instruction booklet, and disk handy when you call. You may be asked to verify that you purchased the program.

If you are unable to call during those hours, you may be able to get help from a special online bulletin board that Sierra has set up to assist players. Of course, your computer must be equipped with a modem and communications software to use this option. The bulletin board is open 24 hours a day, seven days a week. Between the hours of 4:00 p.m. and 9:00 p.m. PST (7:00 p.m.–midnight EST), you may address your questions directly to an online customer-service representative (SYSOP).

When the SYSOP is off duty, you may be able to get help from other users who are signed on. Or you can leave an electronic letter for customer service to answer. The only charge for this service is the long distance call you must place to reach the bulletin board. The telephone number is (209) 683-4463. There are just 16 lines, so you may occasionally reach a busy signal. Keep trying.

Sierra's help isn't limited to installation procedures and hardware problems. Although we think this book has all the clues you'll need to solve the quests, we have avoided giving away too much. The fun of adventure games is figuring them out for yourself, but something may come up that you just can't solve. When this happens, call customer service. You can ask them, for example, where the magic wand is in *King's Quest III*. (It's not in the wizard's bedroom.) Or late night questers can call the Sierra bulletin board and ask questions of whomever is signed on. And you'll probably get the right answer—more than 29,000 players used the bulletin board in its first six months of operation.

(Other game bulletin boards located around the country have sections set aside for King's Quest fans. One particularly active group meets on CompuServe.)

If all else fails, you can write a letter to Customer Service at Box 485, Coarsegold, CA, 93614. They receive 2,400 letters a week, and they answer all of them within three days. Well, most of them anyway.

Getting stuck is no fun, but it doesn't mean you are stupid. Appendix D contains the most often asked questions about each of the quests. We won't tell you the answers (you have Sierra Customer Service for that) but we do provide a clue to the answer.

There's still another source of information about King's Quest. For each game, Sierra On-Line publishes hint books you may order by calling a toll-free number. The answers in these books are printed in invisible ink that becomes visible as you rub the text with a special felt-tipped pen. That way you can't "accidentally" see a clue.

To order a hint book, or any of the Sierra games, call the order-line number. The hint books are \$7.95 each; all major credit cards are honored. Shipment is by third-class mail, but if you just can't wait, an extra \$4 will bring the book to you second-day express. The order line is toll-free: (800) 344-7448.

Don't put your quest on hold if you can't figure something out—call or write for help.

❧ **Questing: The Art of Moving** ❧



Playing King's Quest is like playing with a cartoon. The main character, known as Ego (see Chapter 2), is propelled around the three-dimensional screen by moving the computer's joystick or cursor keys. Ego's speed can be varied by typing SLOW, NORMAL, or FAST. It's useful to slow him down in places like Dracula's Castle when he is climbing the tricky spiral stairs, and to speed him up when he's strolling in areas where a bandit or ogre may suddenly appear—if he's fast enough, he may be able to run to the next screen.

Although you can play King's Quest by using the cursor keys on the keyboard, the game is designed for joysticks. The secret to staying alive, if there is a secret, is to look carefully where you walk or swim and stay near the edge of the screen until you are sure there's nothing dangerous lurking. There is no creature that will chase you from one screen to another, although it may pop up after you've been in a screen for a while, and it may pop up in a different screen at a later time.

• The Art of Talking and Taking •



he adventure in an adventure game is exploring every nook and cranny to find clues and objects that may be useful in solving the quest or puzzle. When you spot something of interest, or you want Ego to speak or perform an act, type on the keyboard. LOOK AT THE TREE, TALK TO THE KING, TAKE THE SPOON, SWIM, JUMP, and GIVE NECKLACE TO MERMAID are all examples.

Part of the King's Quest software is an interpreter or parser that looks at what you type and tries to figure out what you said. Computers aren't very good at understanding English, so you must keep it simple. The parser does not understand questions, so you can't say things like WHERE IS THE MAGIC WAND? And it does not understand complex sentences like LET ME OUT OF HERE OR I'LL KILL YOU.

The King's Quest parser does understand simple verb/noun sentences like OPEN THE DOOR and TALK TO THE SAILOR. Generally one or two words are all you'll need. The program ignores words like A, AN, THE, MINE, MY, YOUR, YOU, IT, ITS, THIS, THAT, THESE, THOSE, IN, TO, IS, IF, AT, WHO, WHY, WHAT, WHEN, WHERE, PLEASE, and most adjectives, although it's not wrong to put them in. In fact, that's what a parser does: It extracts words it recognizes from a string of characters and matches them to predefined actions.

The major verbs King's Quest understands are: LOOK, OPEN, MOVE, GET, TAKE, GIVE, and KILL. Each game has a unique set of nouns that identifies the objects in that game. *King's Quest III*, for example, understands BREAD, FRUIT, and MEAT because those are all items found in the kitchen of the wizard's house. The parser is smart enough to know what objects are in what rooms, so if you say TAKE THE BREAD while you are outside in the chicken coop, the program will reply HOW CAN YOU DO THAT? If you stand by the fireplace in the kitchen and try to take the bread, the computer may say YOU ARE NOT CLOSE ENOUGH.

In order to give the game a larger vocabulary, the parser recognizes synonyms for many nouns and verbs. For example EXAMINE, FEEL, SHOW, SEE, VIEW, and LOOK ON are all synonyms for LOOK. GET has five synonyms, INVENTORY has ten, and in *King's Quest III* the word MAN has twenty-seven synonyms. Some versions also have a list of so-called four-letter words that prompt the program to scold you for using them.

A few words control the game itself. Typing QUIT or STOP ends the game, SAVE saves the game (more about that later), and STATUS shows what you have collected. Most control words have function-key equivalents on MS/DOS computers. Pressing F5, for example, is the same as typing SAVE.

After you have entered an instruction, the software interprets it and the computer carries out the action. Correct spelling and typing are important, although capitalization is ignored. DOOR, DooR, DoOr, and door are all the same, but DORE is unknown. When King's Quest can't figure out what you had in mind, it will say something like WHAT'S A DORE? Anytime a message or reply appears on the screen, the program pauses to allow you time to read it; to continue, you must press the enter key until no messages appear.

• The Science of Saving •



aving is an important concept in *King's Quest*. If you don't believe that, you soon will after you begin playing. Suppose you have just spent 30 minutes trying to get into the witch's house without her being home. Finally you succeed and find some really nifty things laying about (hint: food and reading matter). You grab them and run out the door to the next screen, where you are attacked by an ogre who kills you. Now you've got to start all over again.

But the good folks at Sierra recognized that no one—including the programmers who wrote *King's Quest*—can play these games from start to finish without making a mistake, falling down the stairs, or being mugged in the woods. It just can't be done. So the save facility allows you to save a game in progress and then return to that point if some misfortune should befall you.

Saving isn't automatic. You've got to tell the program when to do it, and you must give a name to the point at which you are making the save. You can save up to 12 games in a single subdirectory, and it's a very good idea to take advantage of this. In the example above, it would be prudent to have at least three separately saved games: before going into the house, just in case the witch was home; once inside, so you could come back to look around if something happened; and as soon as you are safely out the door.

It's also a good idea to keep some major game checkpoints until you've finished the quest. In *King's Quest I*, for example, you can find yourself in a hole with no way out unless you have a certain goodie to munch on. If you didn't get that tidbit, and you don't have any saved games that will get you out of the hole, you might as well be dead. You have to start all over.

Saved games also allow several people in the same house to play *King's Quest*. Each player sets up a floppy disk for saving or a separate subdirectory on a hard disk. Then you can save the game and come back to it later, picking up where you left off. This will not interfere with other players.

Part Two

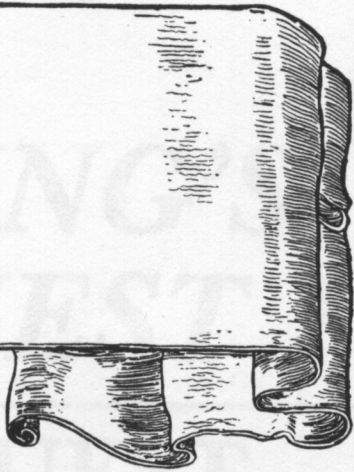

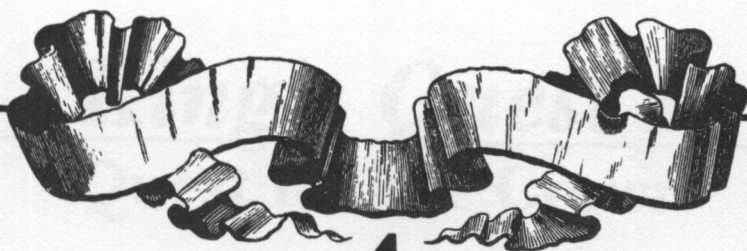

4

KING'S QUEST I

QUEST FOR THE CROWN

King's Quest I

Quest for the Crown



You are Sir Graham. You have been summoned to Daventry by old King Edward to find three treasures he has let slip from the realm. The treasures are a chest of gold, a magic shield, and a magic mirror. It's your job—your duty—to find the missing prizes and return them to King Edward.

To succeed in your quest you will have to visit every corner of Daventry. Although there is no fixed path for your travels, it is sometimes necessary for you to have one object before you can use another object. For example, what good is a slingshot if you don't have ammunition?

• Traveler's Tips: Getting Started •

Daventry is where your quest takes place. Although early travelers and explorers had to make their own maps with quill and parchment, we've included some modern versions in this book to help you find your way. We have divided the country into four areas or quadrants. In addition to the quadrant maps which cover Daventry proper, there are separate maps to show places like the Land of the Clouds and the Land of the Leprechauns.

The Kingdom of Daventry is small and compact; it is just eight screens from east to west (left to right) and six screens from north to south (top to bottom). Each quadrant map is four screens across and three screens up and down. In almost every case, Daventry, like the real world, wraps around itself: If you go east (right) from Edward's Castle, which appears on the northeast map, you'll end up at the beautiful lake shown on the northwest map.

You begin at the right side of King Edward's castle, which is located in the northeast quadrant. Take a moment to find your location on the map.

Now, walk across the bridge and keep going until you come to the castle doors. Go up the steps to Edward's castle. To get inside, you must type OPEN DOOR. Once the door swings open, you may enter. Notice that you got one point for entering the castle.

Walk down the hall and make a left; eventually you will be in the Throne Room. There's nothing you can do or take in these halls, but you should always try things like talking to the guards and peering into corners.

Approach King Edward and say TALK TO KING. Edward will tell you about your quest. Then you can make your way out of the castle to begin the quest in earnest.

• Puzzle •

King's Quest wouldn't be much fun if we told you how to solve all of its riddles and puzzles. To help you along, without giving too much away, this crossword puzzle provides some important clues. Look it over and fill in the answers you know. As you make your way around Daventry, come back to the puzzle and fill in the blanks. It may be the only way to discover the gnome's name.

No fair looking at the answers in the back of the book. In fact, there are no answers in the back of this book—the Ogre ate them.

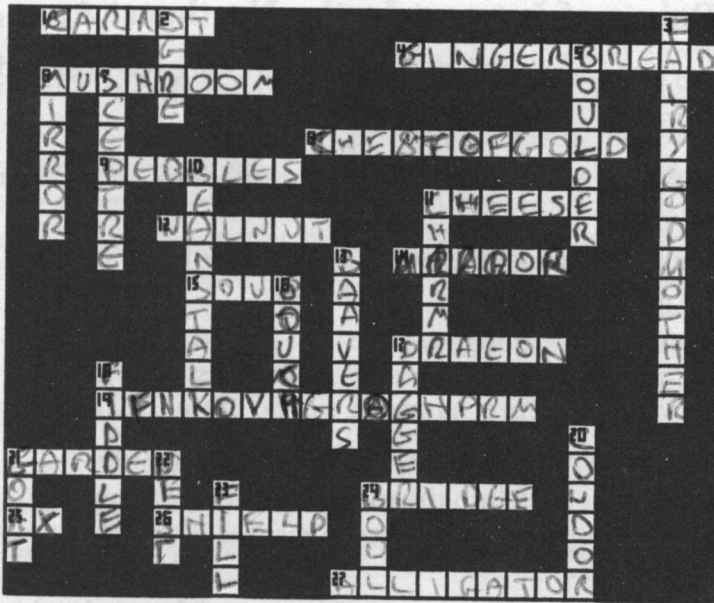

Across

1. Grows in garden behind castle
4. Material used to construct witch's house
6. Magic fungi
8. One of the three treasures (3 words)
9. Found beside the river
11. Rat food
12. Delicious nut
14. Located in bottom of well
15. Nourishment for woodcutter
17. Lives in cave at bottom of well
19. The gnome's name
21. Located behind castle
24. Defended by a troll
25. Woodcutter's tool
26. One of the 3 treasures
27. Swimming around castle

Down

2. Evil little man
3. Giver of good spells (2 words)
5. Large rock
6. One of the three treasures
7. Belonging to leprechaun king
10. Used for a ladder
11. Some are lucky
13. Found in hollow log
16. Location of diamonds
17. Found under a rock
18. Makes music
20. California bird
21. Lives in a pen
22. Location of golden egg
23. Inscription on bowl
24. Red container

☛ Points of Interest In the Northeast Area ☛

This part of Daventry has several interesting features and attractions.

- † Be sure to stop at the rock in the forest; it's like no other rock you'll roll.
- † There are some pebbles lying on the river bank and they will surely come in handy in a high place.
- † The ugly purple thing on the island is food. You can't get to it by swimming across the river, but you must have it before you meet with the Leprechauns. It will be useful in a tight place.
- † The boulder with the small hole is not an entrance.
- † You can't get back into the castle until you've completed your quest and collected the three treasures. Only then will the doors unlock.
- † The boulder in the river looks like a special rock, but it's just an ordinary boulder. No kidding.
- † The biggest challenge in this area is getting to the island, but you can't get there from here.
- † When you finish the quest, you must still show respect for King Edward.

☛ Points of Interest In the Northwest Area ☛

- † There's an island in this area that you'll want to visit. There are two bridges to the island but they're guarded; for maximum points don't give up a treasure to cross a bridge. It might be helpful to review the fairy tale "Billy Goats Gruff."
- † The woodcutter's yard has an ax and a rusty pump. They were put there by evil artists to drive you mad trying to figure out what to do with them. You can't do anything with them, but don't tell your friends.
- † A lot goes on in the woodcutter's house. In fact, it is so busy in here that the programmers had to pull a fast one to get everything to work. Watch what happens to the woodcutter when

you put a bowl on the table. He briefly disappears because this game is written with an early language that allowed only four animated objects per room. Words of advice: Charity begins here; stay out of corners.

- † The most difficult part of *King's Quest I* is guessing the gnome's name. But it's not that tough. You *can* figure it out. A clue is written on a paper inside the witch's house. Your first idea is probably the right one, but you need to carry it a little further. Remember the fairy tale with the old man who had the funny name?
- † If you should be given some seeds, review "Jack and the Beanstalk."
- † Seeds seem to thrive in the flower patch, and may even sprout outside a cave in the southwest area.
- † Diamonds are a quester's friend; go back and look again if you haven't found any.

Points of Interest In the Southeast Area

This is an uncivilized area with several menacing creatures lurking in the woods. Be ready to run to another screen at the first sign of danger. If you don't run fast enough you may be frozen for a while, or even killed.

- † An elf may appear in several places; he is not to be feared. Indeed he may give you something.
- † The wolf, ogre, troll, dwarf, witch, and sorcerer are bad; they will do you harm.
- † Stop by the mountain. There's a door in its base and like everyone else, you will want to get inside. There are two ways to do that, and you get the most points by not going in the door.
- † There are two trees in this area that have delighted visitors for generations. They both yield golden treasures.
- † Good things come in small, brown, woody packages.
- † Remember to eat your veggies—and show them to dumb four-legged creatures.

Points of Interest In the Southwest Area

- † Among the attractions in this area are a delicious house and a smelly old goat in a pen with a gate.
- † The house has a clue to the gnome's name; and the goat is an answer to the troll bridge.
- † Outside the cave is a good place to take some air. You might even catch something there. (Hint: the jump command has a purpose.)
- † Sometimes the house is occupied, and sometimes it isn't. Remember what Hansel and Gretel did to their witch? Don't get caught.
- † Going down in the well can be quite a trip—if you don't have everything you need, it will be your last.
- † You can ride down into the well in the bucket or you can climb down the rope.
- † Keep an eye out for *Trifolium*.

Points of Interest In the Land of the Clouds

- † No matter how you get to Cloud Land, it's a dangerous journey and you'll have to be careful not to fall.
- † Walking on clouds is an ethereal experience and requires great care.
- † You find the strangest things tucked away at the bases of trees.
- † Remember "David and Goliath?"
- † King's Quest rewards patience. Don't be so quick to use your weapons.

Points of Interest In the Land of the Leprechauns

- † There's only one way out of the cave with the hole in the ceiling . . . and it's not the way you came in.
- † Leprechauns are Irish and set great store in the color green, fiddle music, and shamrocks.
- † You can take two things out of the throne room besides yourself; one is difficult to spell.
- † The throne room is a good place to fiddle around.
- † If you don't have tasty fungi to munch on, you are doomed to spend the rest of your quest underground.

Points Not of Interest

Sometimes it's fun to live on the edge. Try some of these things, but only after you've saved the game.

Stand in front of the rock when you move it
Let the witch have you for dinner
Do a swan dive into the moat surrounding the castle
Pet the giant rat
Step on the dragon's tail

Other Points of Interest

(Also known as scoring)

King's Quest awards points for finding and using items scattered around Daventry. How you use what you find also affects your score. King's Quest does not reward violence or payoffs. If you get or do something peacefully you will receive a higher score.

The maximum points you can earn for *King's Quest I* is 158.

Maps for *King's Quest I*

Northeast Daventry

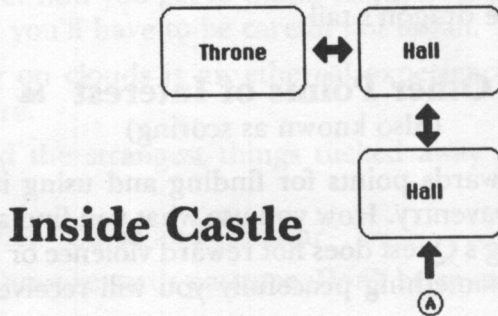
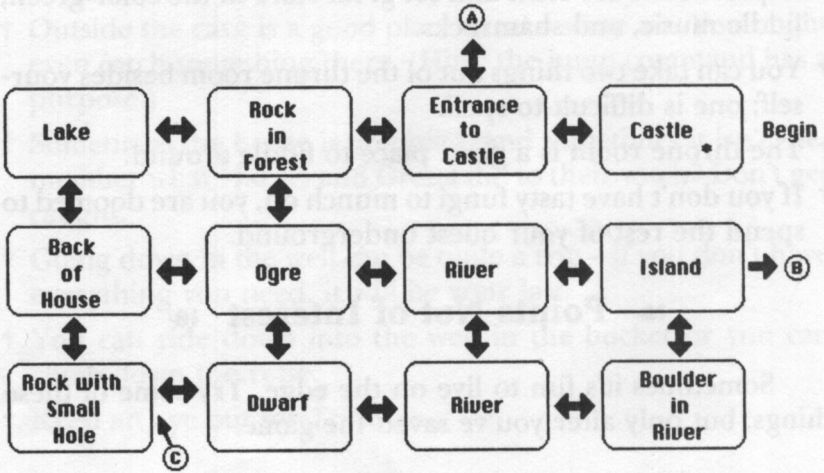

Land of the Leprechauns

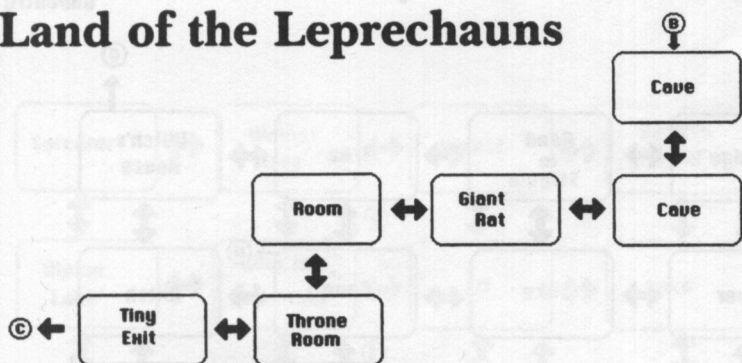

Northwest Daventry

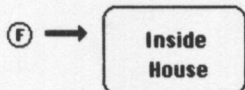
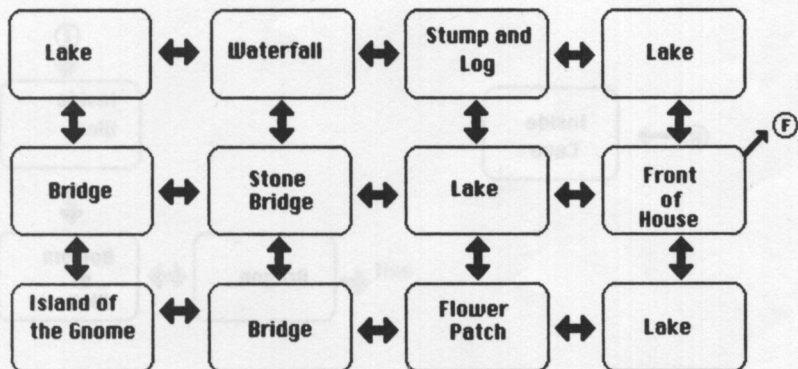

Southwest Daventry

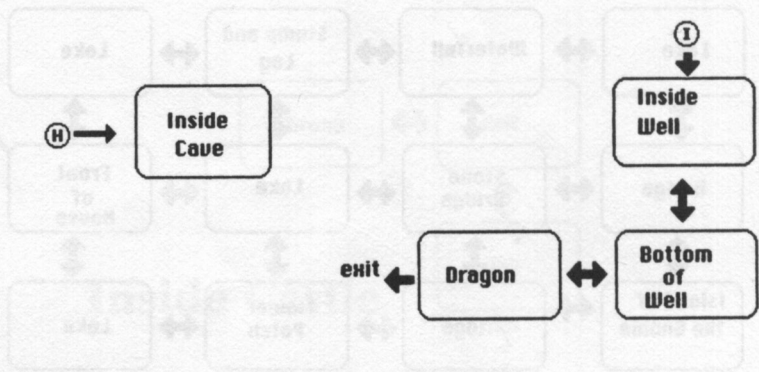
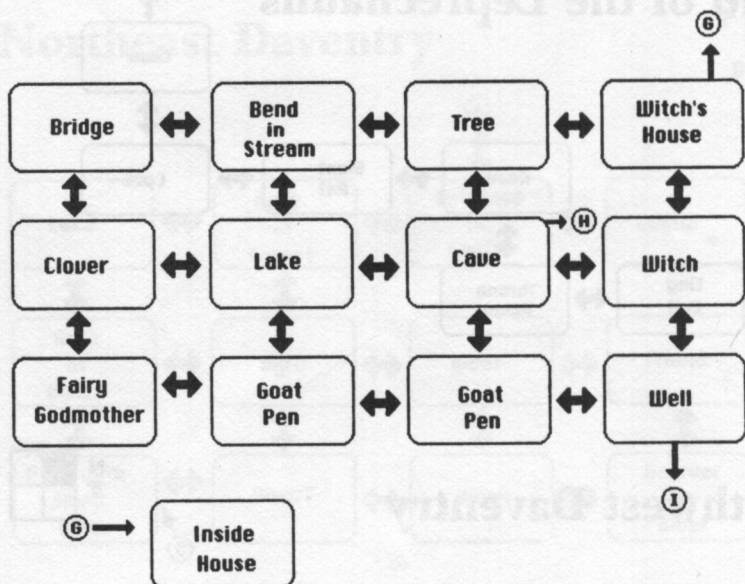

Southeast Daventry

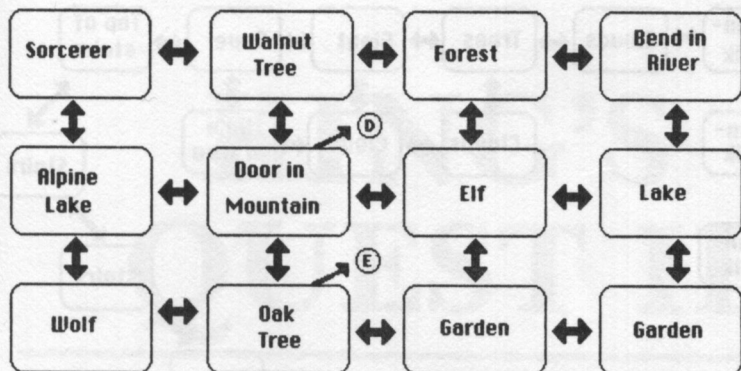

Land of the Clouds

↑_N

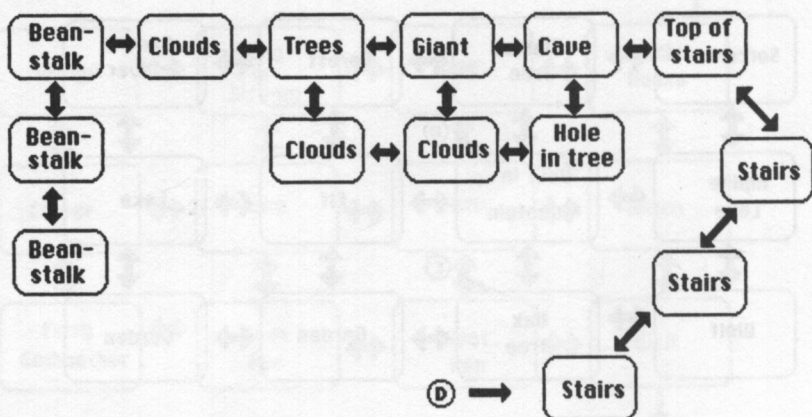

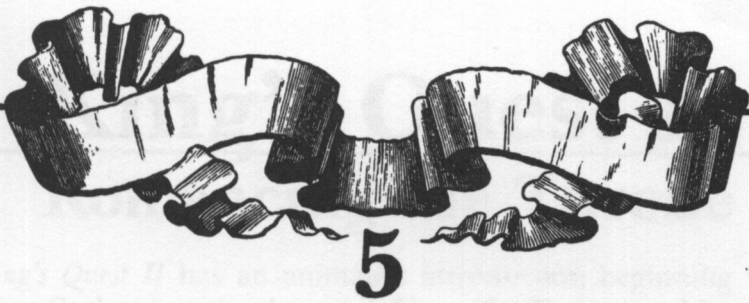

KING'S QUEST II

ROMANCING the THRONE

King's Quest II

Romancing the Throne

King's Quest II has an animated introduction beginning with King Graham on the throne in his castle. To bypass this, press the Enter key while on the title screen. To watch the introduction, don't push any keys until Graham is on the beach.



our name is Graham. You're the King of a small country named Daventry. Although you have about everything a king could want—an awesome palace, a hot carriage, and a great job—you are terribly lonely. What you really want is for a beautiful young maiden to become your wife and Queen. Rumor has it that such a lady lives in a tower in a distant land.

You begin *King's Quest II* on the beach of Kolyma, seeking the fair maiden Valance. You'll have to open three doors before you find her. Good luck.

• Traveler's Tips: Getting Started •

Kolyma is where your quest takes place. We've divided it into four quadrants or areas and included some maps to help you find your way. In addition to the quadrant maps that cover Kolyma, there are separate maps for places like Neptune's Kingdom, the Enchanted Island, and even a floor plan of Dracula's Castle.

Kolyma is a rather square country: It's seven screens from east to west (left to right), and seven screens from north to south (top to bottom). In most places you can get to the north by going south since the land wraps around itself. The east-west direction is limited, however, by the ocean and mountains. You can't swim far enough west to meet the mountains on the east.

There is space on the maps to record what you see and hear. In Kolyma, unlike Daventry, people and creatures are not limited to one screen, but may appear at any time in up to six screens. You may encounter Little Red Riding Hood in the area south of Grandma's house one time, and in the area west of Grandma's the next time. You have to stay on your toes.

• Puzzle •

King's Quest II wouldn't be much fun if we told you how to solve all of its riddles and puzzles. To help you along, without giving too much away, this crossword puzzle provides some important clues. Look it over and fill in the answers you know. As you make your way around Kolyma, come back to the puzzle and fill in the blanks. It may be the only way to find out about the rare event outside Hagatha's cave.

No fair looking at the answers in the back of the book. In fact, there are no answers in the back of this book—we had to use them to line the bottom of the nightingale's cage.

• Traveler's Tip: Getting Started •

Kolyma is where your quest takes place. We've divided it into four quadrants or areas and included some maps to help you find your way. In addition to the quadrant maps that cover Kolyma, there are separate maps for places like Neptunia's Kingdom, the Enchanted Island, and even a floor plan of Dracula's Cave.

Kolyma is a rather sparse country. It's seven screens from east to west (left to right), and seven screens from north to south (top to bottom). In most places you can get to the north by going south since the land wraps around itself. The east-west direction is limited, however, by the ocean and mountains. You can't swim far enough west to meet the mountains on the east.

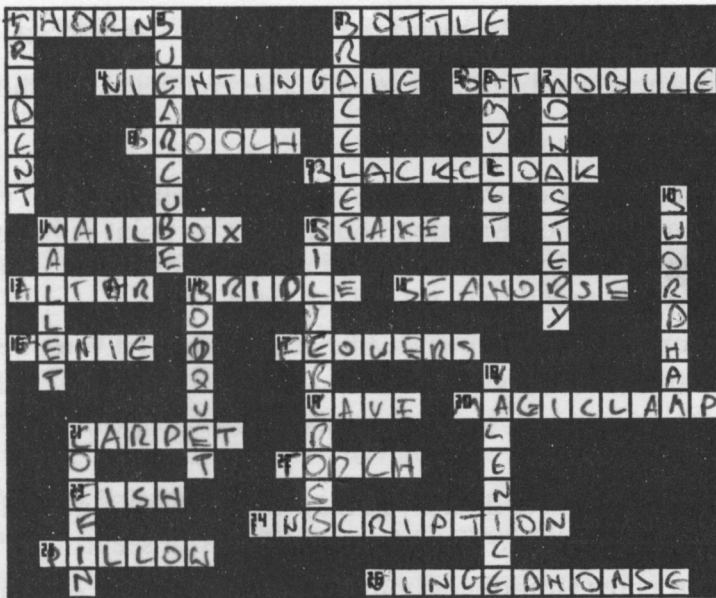

Across

1. Found on some bushes
3. Found in Neptune's kingdom
4. Makes a lot of noise at night
5. Appears outside Hagatha's cave, but rarely
8. A piece of jewelry
9. Disguise needed to cross water (2 words)
11. Location of goodies
12. Used to kill Dracula
13. Found in the monastery
14. Used to harness the snake
15. Transportation to Neptune
16. Lives in an oily place
17. Nice gift for a mermaid
19. Location of a key
20. Found in antique store (2 words)
21. Your way to top of cliffs
22. Used to light a candle
23. Key to getting off blue beach
24. Written above door
25. A key is under this
26. Another form for the snake (2 words)

Down

1. Belongs to Neptune
2. Antidote for brambles (2 words)
3. Piece of jewelry
6. Key to returning to Daventry
7. Location of silver cross
10. Two ways to get rid of a lion (2 words)
11. A wooden hammer
12. Keeps a vampire away (2 words)
14. A bunch of flowers
18. The purpose of this quest
21. Dracula's bed

Points of Interest In the Northwest Area

This is where you begin; the area has several items you should collect.

- † The large rock on the beach plays an important part in your visit to Neptune's Kingdom, but there's no point in hanging around it until you've read the inscription on the first door. Once you've read that, come back here.
- † All women, even fishy ones, like gifts. Perhaps if you offered something that smelled good. . . .
- † The first door isn't in the northwest area—that would be too easy.
- † With all this talk of doors, you may wonder what kind of door you're looking for. You'll know it when you see it.
- † If you enter Grandma's house and find someone else there, you'll want to get out fast. Grandma is triggered by a random number, so keep visiting until she's home.
- † Grandma is in bed, ill. She probably hasn't eaten in days. If you can find something to feed her you'll be ever so much better, as will she.
- † If you don't take two things out of Grandma's house you'll be sorry later.
- † Help Miss Hood find what she has lost, and you'll gain points. She didn't lose sheep; that's another story.
- † The castle in the distance, across the Poisoned Lake, belongs to Mr. Dracula. You can't get to it by swimming.
- † It's hard not to notice the black and brown lake. It makes Love Canal look like a pasture. Just for fun, save the game, and try to swim to the castle.

Points of Interest In the Northeast Area

There are two tourist attractions in the northeast: the Monastery and the Antique Shop. The Monastery is open, but the Antique Shop will remain closed until you read the inscription on the second door.

- † Stop by the Monastery and do what the other people are doing.
- † If you are nice, the monk will give you something.
- † The Antique Shop has one of almost everything, except a caged nightingale. I'll bet the owner would love to have one; that is, if you just happen to have one handy.
- † A Good Fairy hangs out in the area south and east of the Monastery and she may bless you with good luck.
- † An Enchanter haunts the area south and west of the Antique Shop. Be particularly careful around the area where the log extends into the lake.
- † There's a brooch in this area that matches the bracelet found in another area and a necklace found in still another area. An earring is the fourth piece of jewelry.
- † There's no way you can cross the mountains or chasm to the east. QA saw to that.
- † Do you remember the story of Aladdin and his magic lamp? Do you know how to treat a magic lamp?

Points of Interest in the Southwest Area

- † Traveler's warning: Most of this area is marked as dangerous. It's home to the witch Hagatha and the thieving dwarf. Only along the coast are you entirely safe.
- † It's from the area marked *View of Castle* that you can eventually catch a ride to visit the Count.
- † If you loiter outside Hagatha's cave often enough, you'll see something incredible. But the danger of hanging around may far outweigh the amusement of what you'll see.

- † You'll find something belonging to Neptune in this area; please don't call it a pitchfork.
- † There are two ways to capture the nightingale. If you had something to throw over the cage, maybe the dumb bird wouldn't make so much racket. On the other hand, if no one is around, who cares how much noise the bird makes?
- † The dwarf's den has at least two goodies. No, the soup isn't for you: Think elderly.
- † If the dwarf has stolen something from you, you may find your belongings in his den.
- † In the woods, northeast of where you find something for Neptune, take a good look at the trees.

• Points of Interest in the Southeast Area •

- † The dwarf's territory extends into this region so you must be careful.
- † The southeast area is lacking in interesting features, except for one. In this area you'll find the doors.

• Special Section About Doors •

The key to *King's Quest II* is the doors. Here's how they work: Somewhere in Kolyma you'll find a door. To open the door you'll need a key, but you can't find the key until you've read the inscription over the door. So you have to find the door, read the inscription, and then look for the key.

Once you've found the key, you can return and open the door. Then you'll see another door. Now you know *What's behind door number one?* Then you must read the inscription above the door before you can find the second key. Ditto the third door and third key.

The doors are located in a place you can visit only a limited number of times. If you don't do everything right, you can't complete the quest. You can visit the area of the doors only four times:

To find the first door's location and read the inscription over it

To unlock the first door and read the second door

To unlock the second door and read the third door

To unlock the third door

That's the biggest clue you could ever hope to get. I've told you too much. With that knowledge you can't possibly fail.

☛ Points of Interest in the Castle of Dracula ☛

- † You got this far, so you must have figured out one of the two ways to cross the poisoned lake. No? Then you must be reading ahead.
- † You can always pay for passage in a boat, but it's more fun to dress up and pretend to be someone you're not.
- † You can pick your way through a sticky situation or eat a bit of sugar.
- † Did you go upstairs in the castle? There must be something up there. Does that light up your life?
- † Nice torch along the steps. Wonder what you can use it for?
- † Just this once it's all right to kill someone. He's already dead and in his coffin anyway. Don't forget to search the coffin.

☛ Points of Interest in the Kingdom of Neptune ☛

- † Getting here requires the help of a fishy woman and a horse. But you must already know that.
- † Everyone in this game wants something. What do you suppose would appeal to Neptune?
- † Pearls are found in oysters; keys, apparently, are found in clams.
- † There's one more item you can pick up here.

☛ Points of Interest in the Clouds ☛

- † Great place for a restaurant. How was your flight?
- † This place is really classic. If you know mythology you'll probably know what to do with a snake and a bridle. If not, you'll just have to fake it.
- † The bridle? Oops. Didn't you know about the three wishes?

☛ Points of Interest on the Enchanted Island ☛

- † You aren't yet on the island; you're on a very colorful beach.
- † You must make do with what you find around you, and the only thing around here is a net.
- † So, you've got a dying fish, what now?
- † Once in the tower you have only to feed the lion. No, it doesn't eat treasure or chicken soup.
- † If you must, you can slay it but that will cost you.
- † The key to getting home is also on the island.
- † Never say *Never*, just say *Home*.

☛ Points Not of Interest ☛

Sometimes it's fun to live on the edge. Try some of these things, but only after you've saved the game.

- Drink from the Poisoned Lake
- Kiss Hagatha
- Kill the monk
- Kill Grandma
- Open the nightingale's cage
- Let the ghost get you
- Put out the light in Dracula's dungeon
- Walk into the waterfall

Other Points of Interest

(Also known as scoring)

King's Quest II awards points for finding and using items scattered around Kolyma. How you use what you find also affects your score. It does not reward violence (except in the special case of the undead) or payoffs. If you get or do something peacefully you will receive a higher score.

The maximum points you can accumulate in *King's Quest II* is 185.

Maps for *King's Quest II*

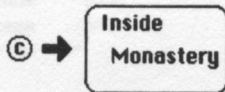
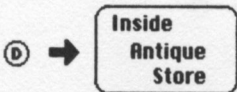
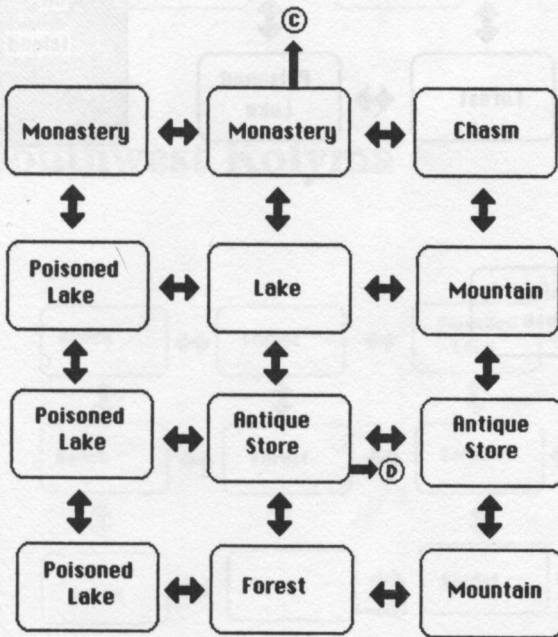

**Northeast
Kolyma**

Northwest Kolyma

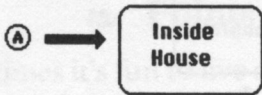
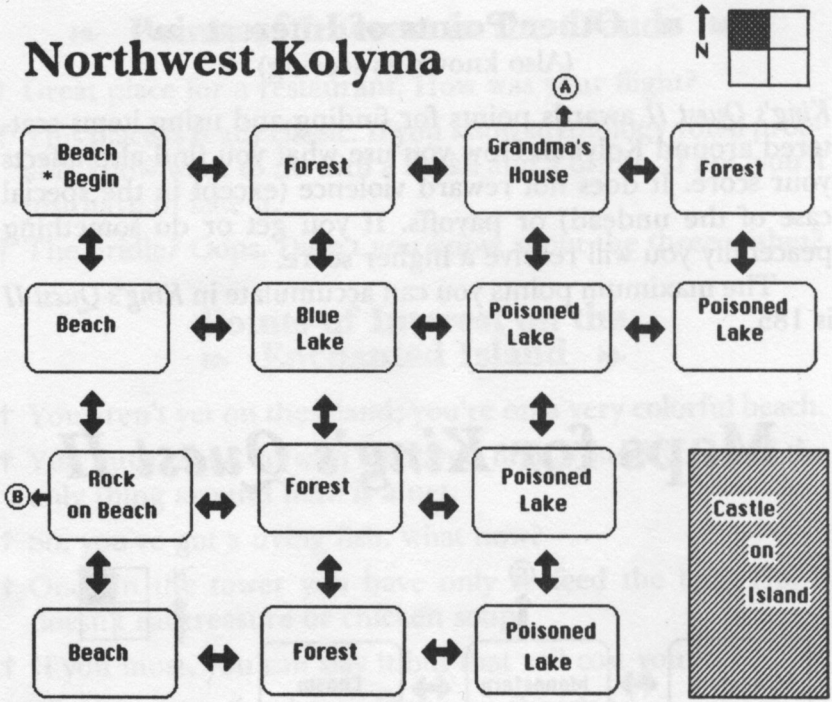

Southeast Kolyma

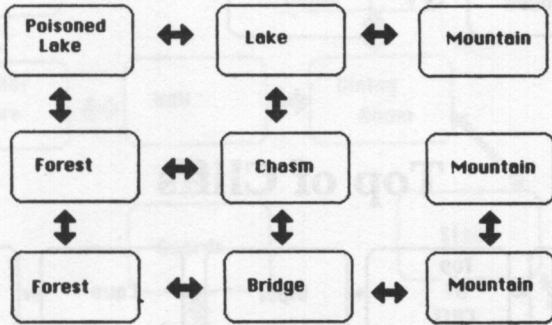

Southwest Kolyma

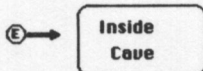
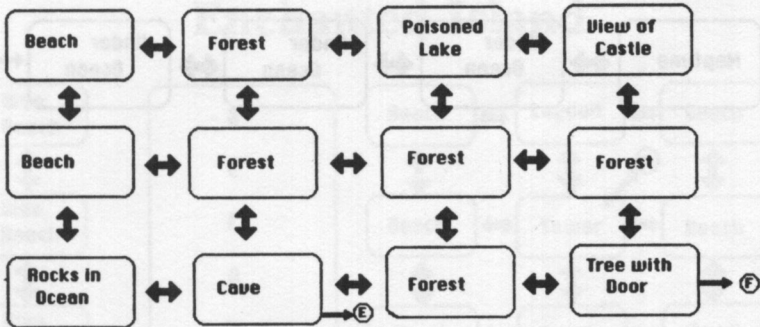

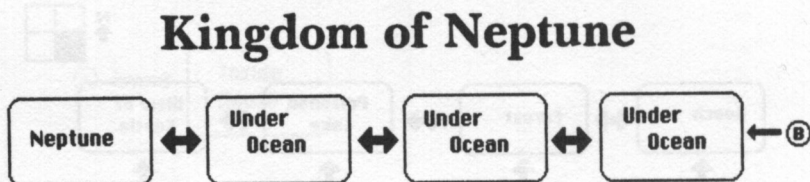
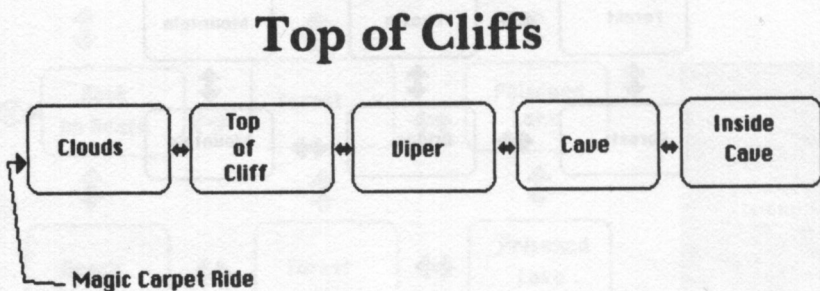
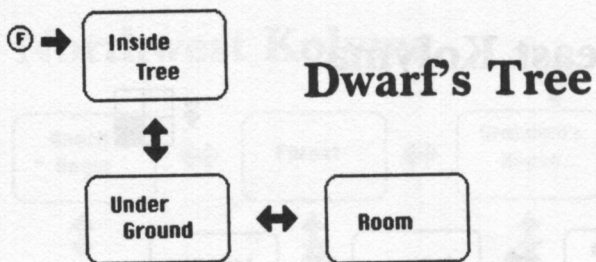

Castle of Dracula

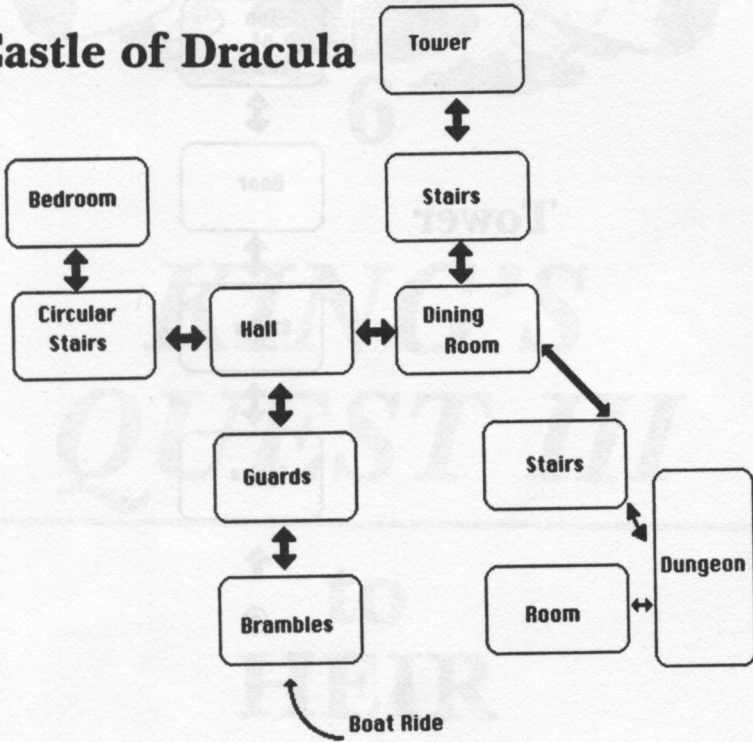

Enchanted Island

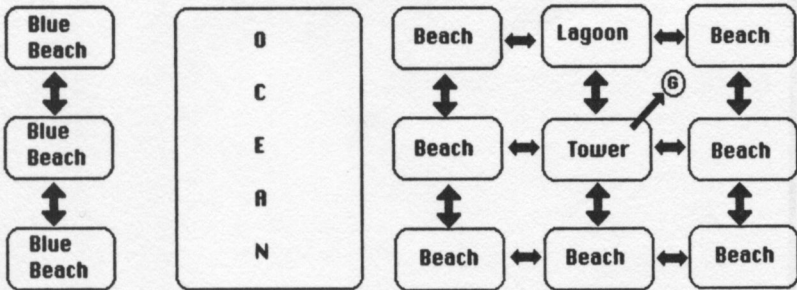

Tower

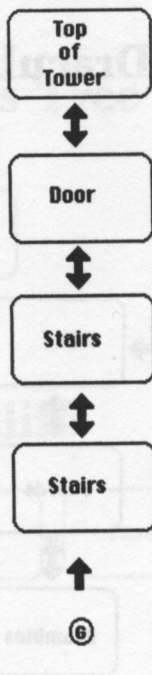



KING'S QUEST III

**to
HEIR
IS
HUMAN**

★ Traveler's Tip: Getting Started

You begin in the entrance hall of the wizard's house. He has just instructed you to finish your chores, and you better do them fast: this wizard is known for his impatience.

While you are working, keep in mind that *King's Quest III* is divided into two parts. First you must escape from the wicked wizard; in the process of escaping you'll find out about the second part of your quest. You might also glance at the maps and travel tips in this book, but be very careful that Mananna doesn't catch you. It's a good idea to mark what you find and where you find it, in case you get lost and have to begin again.

King's Quest III

To Heir is Human

King's Quest III has an animated introductory sequence. To bypass it, press the Enter key. If you would prefer to watch it, don't press any key until the story starts to repeat, then press Enter.



n a far off land known as Llewddor there lives a wicked old wizard named Manannan. Like most of us, he hates housework. One day he discovers that a kidnapped boy makes a dandy housekeeper.

As we join *King's Quest III*, the boy, Gwydion (unfortunately that's you), has reached his seventeenth birthday and lost interest in his chores. He has started to chase girls and hang out in town. Although Gwydion doesn't know it, his days with Manannan are numbered unless he can outwit the wily wizard and escape.

What this has to do with Sir Graham (now King Graham and Queen Valanice of *King's Quest I & II*) is not immediately apparent. But this is indeed the third installment of that continuing adventure.

✿ Traveler's Tips: Getting Started ✿

You begin in the entrance hall of the wizard's house. He has just instructed you to finish your chores, and you better do them fast; this wizard is known for his impatience.

While you are working, keep in mind that *King's Quest III* is divided into two parts. First you must escape from the wicked wizard. In the process of escaping you'll find out about the second part of your quest. You might also glance at the maps and travel tips in this book, but be very careful that Manannan doesn't catch you. It's a good idea to mark what you find and where you find it, in case you fail and have to begin again.

Once the chores are finished, you should look around the house, but don't take anything yet. Manannan will *poof* you if he finds certain things missing.

• Puzzle •

King's Quest III wouldn't be much fun if you knew all the answers in advance. To help you a little, without giving everything away, this crossword puzzle provides some important clues. Complete what you can and come back to it as your quest progresses. It may be the only way to find out what's in the crow's nest.

There aren't any answers in the back of the book. We were going to put them there but the cat chewed on the paper and we had to throw it out. By the way, watch out for that cat—especially on steps.

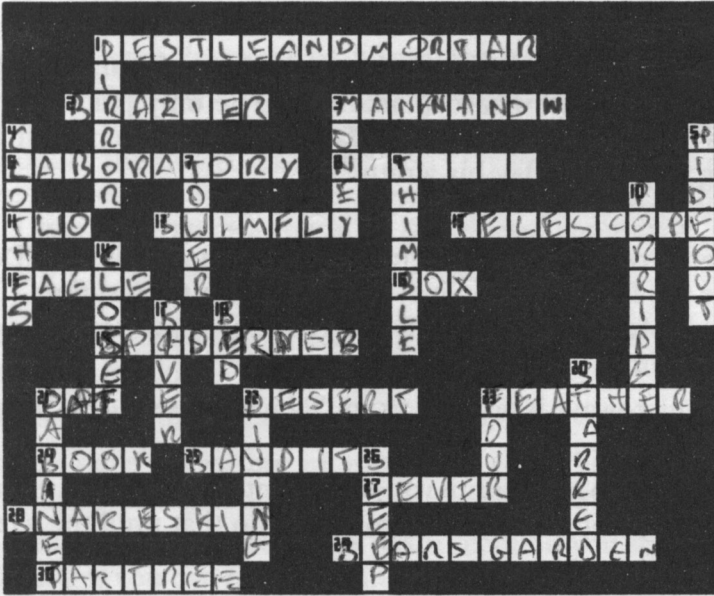

Across

1. Used to grind ingredients (3 words)
2. Used to heat ingredients
3. Wizard's name
6. Place where spells are prepared
8. Found in the crow's nest
11. Number of spells it takes to kill dragon
12. Two ways to get off the ship (2 words)
13. Instrument located in tower
15. Kills the spider
16. Used as a step ladder in ship's hold
19. Guards oracle's den
21. Source of fur for spells
22. Medusa's home
23. Ingredient from chicken
24. Must move this to gain access to Wizard's lab
25. You find money in their home
27. Used to open trap door
28. Ingredient found in desert
29. Source of dew (2 words)
30. Location of bandits' hideout

Down

1. Used to destroy Medusa
3. Needed to board ship
4. Magic map is hidden behind these
5. Located in top of oak tree
7. Location of fly wings
9. Found in bears' bedroom
10. Substance mixed with cookie to change wizard
14. Brass key is on top of this
17. Location of mud
18. Gwydion's hiding place
20. Must hide items marked thus from wizard
21. Location of magic wand
22. Room where Wizard eats porridge
23. Number of items you must buy in store
26. Spell used to disable the pirates

☛ Points of Interest in the Wizard's House ☛

This is where you begin and where you'll spend many unhappy hours serving the wizard Manannan. The only place you are safe is in your bedroom, but if Manannan is out to punish you, hiding will only delay his wrath.

- † There are a lot of good things lying about the kitchen. Don't take the food until you leave the house for the last time. That way if Manannan becomes hungry you'll have something to serve him.
- † The microwave is broken, so you'll have to use the fireplace to cook.
- † You can't do much until you can get into the laboratory (that's *laboratory* not *lavatory*) and you can't do that until the wizard leaves.
- † Manannan is a busy guy. He is also very punctual. Take note of how long he stays away. It's always the same length of time. Twenty-five minutes comes to mind. Or is it fifteen? Ten, maybe?
- † Once you've figured out Manannan's schedule, you can time your explorations by watching the clock at the top of the screen.
- † Be sure to give yourself enough time to hide things before he comes home.
- † Hiding your goodies isn't enough. You must be sure to put everything in the study back the way you found it or Manannan will know you're up to no good.
- † You'll have to make at least one trip down the mountain, probably several, to collect things. Don't get caught in town when the wizard comes home.
- † You must take care of Manannan and there's only one way to make him a pussy cat.
- † Spelling is the key to *King's Quest III*; you must learn to conjure. See the special section at the end of this chapter on spelling.

Points of Interest in West Llewddor

When you come down the path from the mountain you'll be in west Llewddor. The country wraps around itself in the north-south direction, but on the east and west are hideous dangers. Stay out of the desert maze and don't try to swim in the ocean maze. Once you enter these areas, even briefly, it's unlikely you'll ever find your way back. (If that doesn't tempt you, nothing will; be sure to save the game before entering.)

- † There are several important ingredients you'll need to collect in west Llewddor.
- † Money in the form of a purse of gold coins may be found here.
- † If you have something in your ears, you'll be able to hear some interesting things from the smaller creatures.
- † Bandits hang out around the oak tree, but if you stay close to the edges you can escape to another room when they threaten.
- † The desert seems to be free of perils.
- † You'll have to find the bandits' hideout in order to complete the quest.
- † Even bandits sleep sometime.

Points of Interest in East Llewddor

This is the ritzy part of the country, but the waterfront attracts some unsavory characters.

- † There's a molting eagle that sometimes flies around East Llewddor.
- † You have to get into the cave, and that means finding a way to kill the spider. Check your spells.
- † No! Spider's don't make good cats. A different spell.
- † After you solve the mystery of the cave, your ship will come in.
- † Once you've collected your things and are ready to leave Llewddor forever, you can book passage in the tavern.

☛ Points of Interest Aboard the Cruise Ship ☛

- † Surprise! Surprise! This isn't a cruise ship, but you can survive if you lay low.
- † The mice are the key to treasure on the island. You must hear the mice tell you where it is and you must "hear" this in the same game where you dig for the treasure. (The fact that you heard the conversation isn't saved when you save a game.)
- † The treasure is bonus points. You don't have to find the treasure to complete the quest.
- † You can get out of the cargo hold, but you'll have to move some of the cargo. Jump to it.
- † You might as well stay below until the proper time.
- † If you don't disable the pirates with a spell, you'll wish you had.
- † How you get to shore is your own business.

☛ Points of Interest in the Snowy Mountains ☛

- † Getting to the top of the mountain is like an arcade game. Persistence pays off, eventually.
- † You'll be scaling new heights.
- † The big, ugly dude is a snowman. I'd fly right by him if I were you. He looks mean.
- † Getting down the cliffs is another arcade game.

☛ Points of Interest in Daventry ☛

- † You got this far? Excellent! Rest awhile. Talk to the natives.
- † Somewhere in the clouds you'll find your destiny—and Princess Rosella.
- † You'll need to have two spells left to use in the clouds: one right after the other.
- † Don't forget to go by and visit your Mom and Dad when it's all over.

Special Section on Spelling

Spells must be mixed and prepared in the wizard's laboratory which is in a secret place. Some of the ingredients like mandrake root and toadstools are standard items in any lab; others, like mud, lard, and an amber stone are not. You will find them in the house and in the country of Llewddor.

Once you have all the ingredients for a spell, you can and should prepare the potion even though it's not needed at the moment. Spells may be prepared in any order; carry them with you until they are needed. The ingredients are listed in the booklet that came with *King's Quest III*, but in case you lost it, here's what you'll have to find. Check off the ingredients as you find them. Trying to prepare a spell without all the ingredients and measuring tools can be fatal (and amusing).

Understanding the Language of Creatures

Chicken feather
 Tuft of fur from an animal
 Dried snakeskin
 Powdered fish bone
 Thimbleful of dew
 Magic wand

Flying Like an Eagle or a Fly

Eagle's feather
 Fly's wings
 Saffron
 Rose petal essence
 Magic wand

Teleportation at Random

Salt grains
 Mistletoe
 Amber stone
 Magic wand

Causing a Deep Sleep

Three dried acorns
Nightshade juice
Magic wand
Empty pouch

Transforming Another into a Cat

Mandrake root powder
Ball of cat hair
Fish oil
Magic wand

Brewing a Storm

Cup of ocean water
Spoonful of mud
Toadstool powder
Magic wand
Empty jar

Becoming Invisible

Jar of lard
Cactus
Toad spittle
Magic wand

Just finding these items is not enough (and finding them isn't easy). You have to mix them exactly according to the formulas found in the great book and reprinted in the *King's Quest III* booklet. You've lost that too? Okay, here are the directions, but take great care to type and spell everything exactly as it appears. Except for capitalization, everything must match or strange things will happen.

First, you must type **TURN TO PAGE** *n*, where *n* is the page number of the spell in the original *Book of Spells*. The number is listed here after the spell name. One complication: You must type the page number in Roman numerals and you'll have to figure those out for yourself because Llewddor College didn't teach Latin. Then enter the recipe exactly.

Below are the directions for preparing each spell and the instructions for casting it. Don't type the text in parentheses. Remember, it must be entered *exactly* as it appears here.

Understanding the Language of Creatures (Page 2)

Put the small feather in a bowl
Put the fur in the bowl
Put the reptile skin in the bowl
Add a spoonful of powdered fish bone
Put a thimbleful of dew in the bowl
Mix with hands
Separate mixture into two pieces
Put dough pieces into your ears

(Recite this verse)

Feather of fowl and bone of fish
Molded together in this dish
Give me wisdom to understand
Creatures of air, sea, and land

Wave the magic wand

(This spell takes effect immediately. You will be able to hear small creatures, but you won't be able to talk to them.)

Flying Like an Eagle or a Fly (Page 4)

Put a pinch of saffron in essence

(Recite this verse)

Oh winged spirits, set me free
Of earthly bindings, just like thee
In this essence, behold the might
To grant the precious gift of flight

Wave the magic wand

(To cast this spell, type either:

DIP THE EAGLE FEATHER IN THE ESSENCE

or

DIP THE FLY WINGS IN THE ESSENCE

Eventually the spell wears off, but you can end it early with a special chant. Unfortunately, that chant is missing. You should have bought the game.)

Teleportation at Random (Page 7)

Grind a spoon of salt in a mortar

Grind the mistletoe in the mortar

Rub the stone in the mixture

Kiss the stone

(Recite this verse)

With this kiss, I thee impart

Power most dear to my heart

Take me now from this place hither

To another place far thither

Wave the magic wand

(To cast this spell, type

RUB THE STONE

You can't, however, choose your destination and it may be no better than where you are—it may even be worse.)

Causing a Deep Sleep (Page 14)

Grind the acorns in a mortar

Put the acorn powder in a bowl

Put the nightshade juice in the bowl

Stir the mixture with a spoon

Light a charcoal brazier

Heat the mixture on the brazier

Spread the mixture on a table

(Recite this verse)

Acorn powder ground so fine

Nightshade juice like bitter wine

Silently in darkness you creep

To bring a soporific sleep

Wave the magic wand

Put the sleep powder in the pouch

(To cast this spell, which brings a deep sleep to all in the area, type

POUR POWDER ON GROUND

and then say

SLUMBER, HENCEFORTH!

The sleep spell can only be cast in a dark and damp place like a storage area.)

Transforming Another into a Cat (Page 25)

Put mandrake root powder in a bowl

Put the cat hair in the bowl

Put two spoons of fish oil in the bowl

Stir the mixture with a spoon

Put the dough on the table

Pat the dough into a cookie

(Recite this verse)

Mandrake root and hair of cat

Mix oil of fish and give a pat

A feline from the one who eats

This appetizing magic treat

Wave the magic wand

(This creates the famous Cat Cookie rumored to be even better than Famous Amos cookies. If you can't think of someone you want to eat this cookie, then you should give up the quest. But he won't eat it unless you crumble it up in something else.)

Brewing a Storm (Page 84)

Put a cup of ocean water in a bowl

Light a charcoal brazier

Heat the bowl on the brazier

Put a spoon of mud in the bowl

Add a pinch of toadstool powder

Blow into the hot brew

(Recite this verse)

Elements from the earth and sea
Combine to set the heavens free
When I stir this magic brew
Great god Thor I call on you

Wave the magic wand
Pour the storm brew into the jar

(To cause a terrifying storm, type

STIR THE BREW WITH MY FINGER

and then recite

BREW OF STORMS, CHURN IT UP!

There is a way to cause the storm to stop early, but the paper on which it was written became wet and is now illegible.)

Becoming Invisible (Page 169)

Cut the cactus with a knife
Squeeze the cactus juice on a spoon
Put the cactus juice in a bowl
Put the lard in the bowl
Add two drops of toad spittle
Stir the mixture with a spoon

(Recite this verse)

Cactus plant and horny toad
I now start down a dangerous road
Combine with fire and mist to make
Me disappear without a trace

Wave the magic wand
Put ointment in the empty lard jar

(This vanishing cream can be used in only one place—in mist and fire. That's just as well because you have only enough for one application. To use it, type

RUB OINTMENT ON BODY

It lasts only a short time.)

Points Not of Interest

Sometimes it's fun to live on the edge. Try some of these things, but only after you've saved the game.

- As you descend the lab steps, kick the cat
- Go for a dip in the ocean maze, and try to return
- Stroll through the Great Western Desert
- Lie on your bed
- Look behind the tapestry in the hall outside your bedroom
- Take a long walk on a short plank (let the pirates get you)
- Prepare each spell incorrectly and watch how you die
- Hug the snowman
- Ignore Manannan's orders

Other Points of Interest

(Also known as scoring)

King's Quest awards points for finding and using items, and for brewing and casting spells. The maximum points you can earn for *King's Quest III* is 210.

Maps for *King's Quest III*

Wizard's House

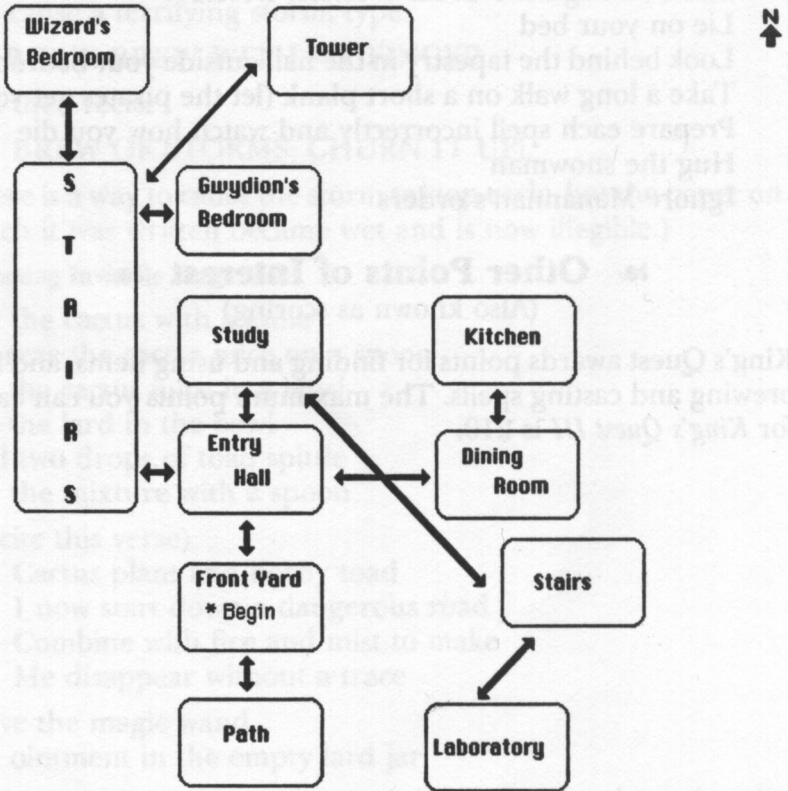

West Llewldor

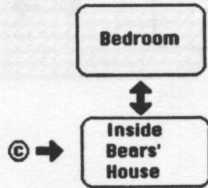
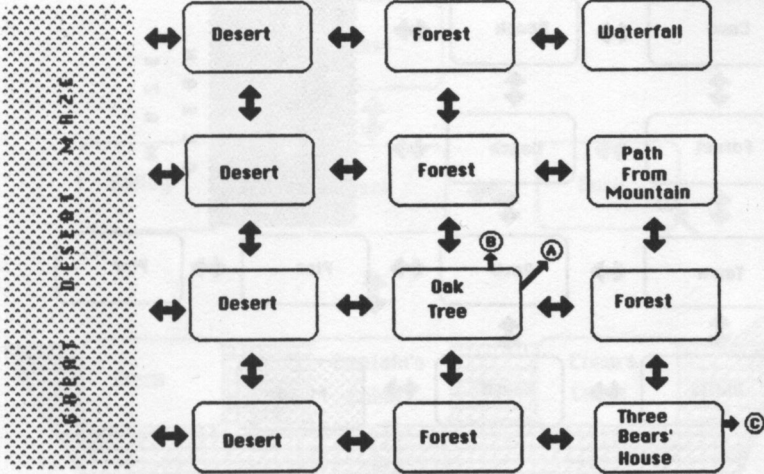

East Llewodor

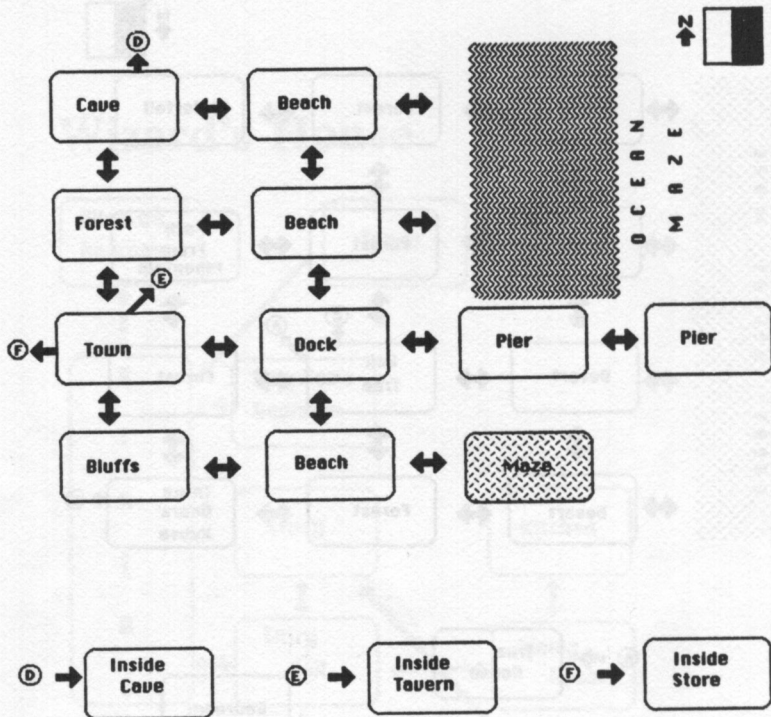

Ship

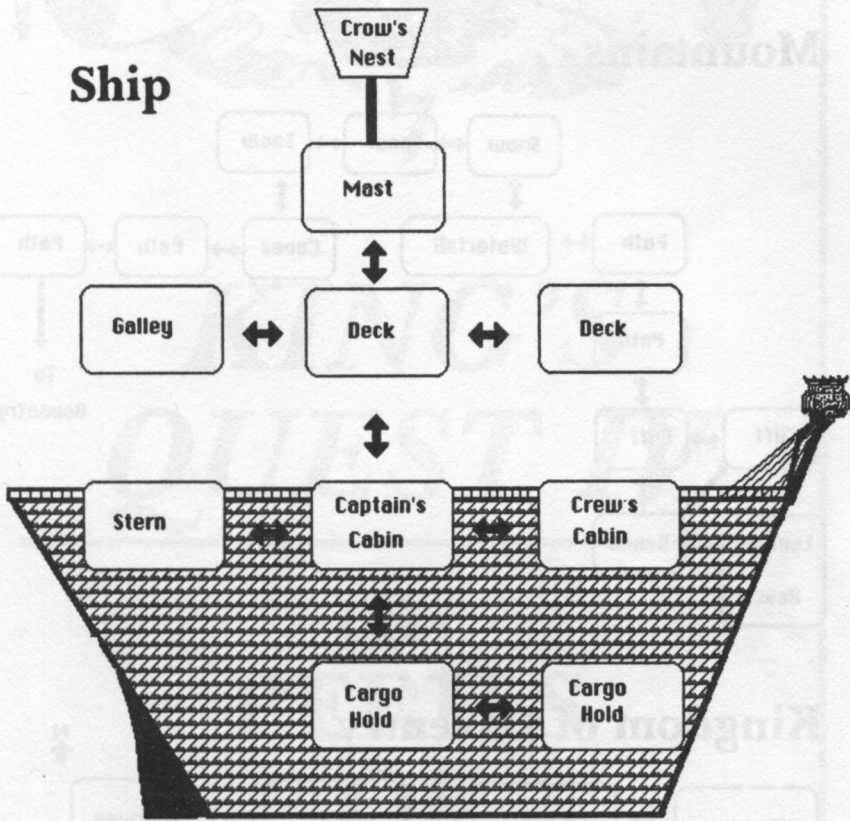

Mountains

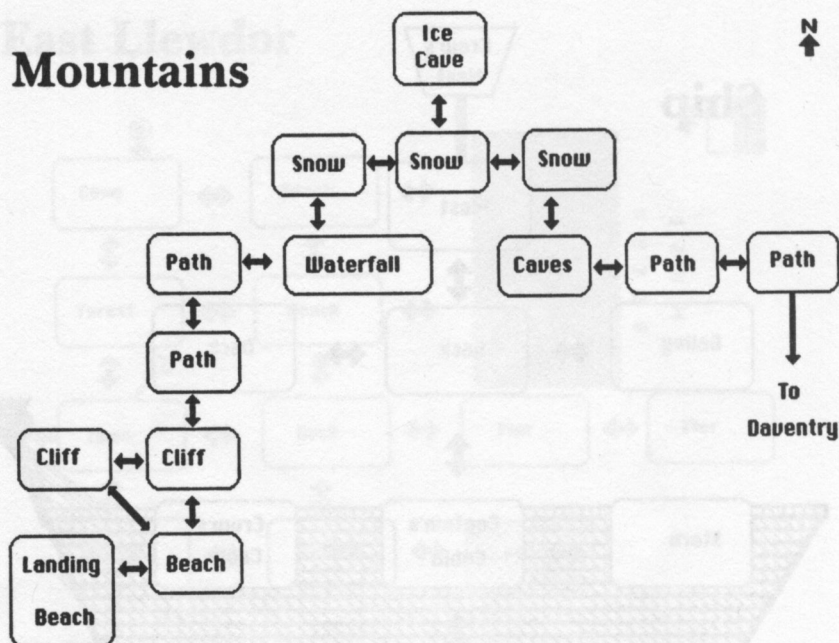

Kingdom of Daventry

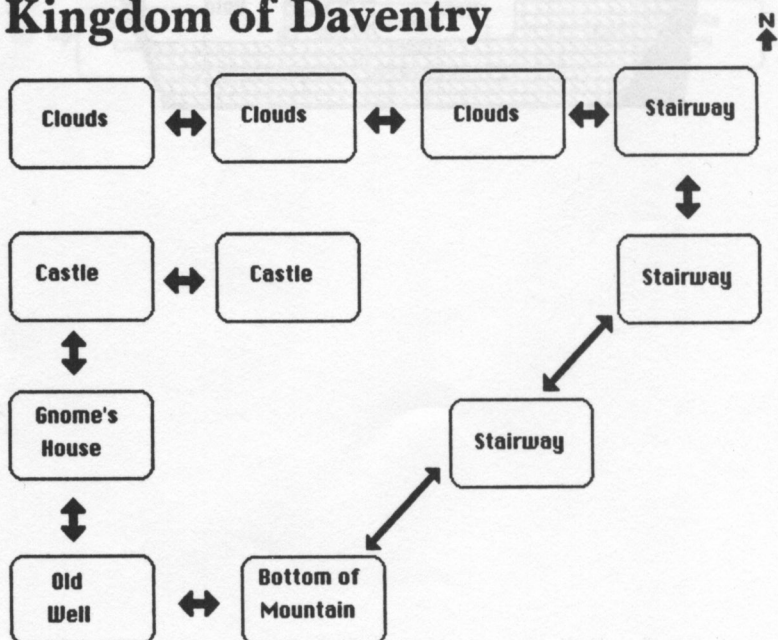

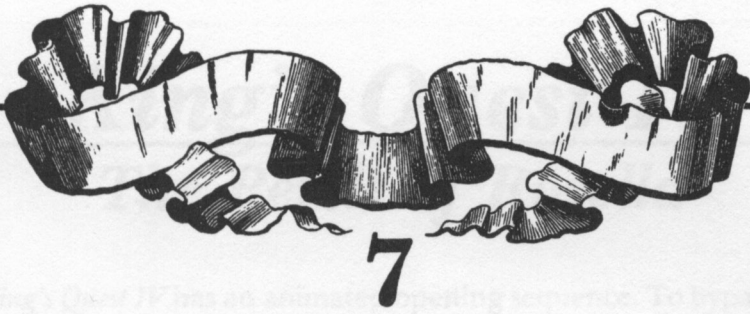

KING'S QUEST IV

the
**PERILS
OF
ROSELLA**

King's Quest IV

The Perils of Rosella

King's Quest IV has an animated opening sequence. To bypass it, press the Enter key. If you would prefer to watch it, don't press any key until the introduction starts to repeat, then press Enter.



Prince Alexander (first known as Gwydion in *King's Quest III*) and his sister Princess Rosella are in the throne room with their parents, King Graham and Queen Valanice. Suddenly King Graham clutches his chest and falls stricken to the floor.

In *King's Quest IV*, you play the role of Rosella. You embark on a quest to find a magic fruit that will restore your father's health. It turns out that finding the fruit is just the first of five tasks you must complete that day.

In order to get an important talisman, you must also find and deliver three items to an evil witch named Genesta. Then you must try to save the good fairy who helped you. This must all be accomplished in just one Tamir day.

☛ Traveler's Tips: Getting Started ☛

As the game begins, you find yourself deposited in the land of Tamir. Your first order of business is to explore the area, picking up whatever isn't nailed down. Look under bridges, do good deeds, and remember you're a girl so it's okay to act like a girl in a fairy tale: You can kiss cute green things and do chores with a song in your heart.

The map of Tamir is divided into two parts: west Tamir and east Tamir. West of west Tamir, in the middle of the ocean, is a small island. East of east Tamir are high mountains, but there is a path through them. It's a good idea to keep track of where you are and what you find on the maps; you can never tell when you'll pass this way again.

King's Quest IV is a race against the clock, but the clock keeps Tamir time. Many things change when night falls. For example, you can't enter the fisherman's shack after the sun goes down. He and his wife are sleeping and don't appreciate being awakened. And the witch's hangout is no longer easy to visit. Your greatest challenge is doing as much during the day as you possibly can. You have just 24 Tamir hours to complete your quest.

This adventure game has numerous animation sequences where the computer takes over the story. Be patient, you can't use the keyboard or joystick while the computer is talking.

There's no point in just standing on the beach looking helpless; start walking.

• Puzzle •

King's Quest IV wouldn't be half the fun if you knew all the answers. To help you a little, without helping you a lot, this crossword puzzle provides some important clues. Complete what you can and come back to it as your quest progresses. It may be the only way you learn what weapon to use on Lolotte.

There aren't any answers in the back of the book. They were there, but Rosella threw them out when she cleaned house.

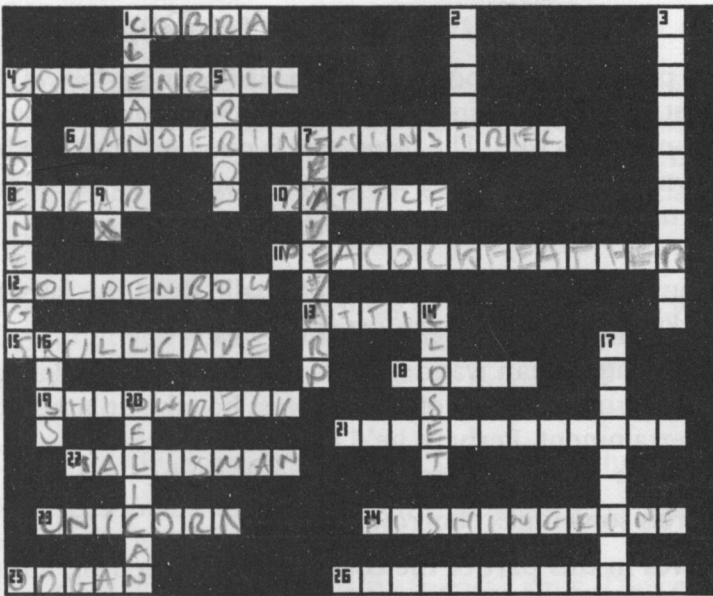

Across

Down

- 1. Lives on the swamp island
- 4. Hidden under a bridge (2 words)
- 6. Plays a lyre (2 words)
- 8. Lolotte's son
- 10. Give to baby
- 11. Only way out of whale (2 words)
- 12. Cupid's tool (2 words)
- 13. Location of sheet music
- 15. Where the three witches live (2 words)
- 18. Needed to get to the fruit tree
- 19. Location of bridle
- 21. Location of ax (2 words)
- 22. Item needed to cure good fairy
- 23. A magic white horse
- 24. What you take from the fisherman's house (2 words)
- 25. Found in haunted house tower
- 26. Used to harness the unicorn (2 words)

- 4. What you must do for the seven dwarfs
- 2. Location of Pandora's box
- 3. Use on unicorn (2 words)
- 4. What the hen lays (2 words)
- 5. Used to kill Lolotte
- 7. Where you dig with shovel
- 9. Needed to escape grabbing trees
- 14. Hiding place in Ogre's house
- 16. What you do to the frog
- 17. Used to quiet old man with chains (3 words)
- 20. Likes to eat fish

Points of Interest in West Tamir

This is a pleasant place populated by a wandering minstrel, Pan the flutist, a funny-looking white horse called a unicorn, and a fisherman and his wife. The fisherman is poor and lives in a broken-down house, but he is nice when you get to know him. There's not much to fear in west Tamir.

- † Do you know where to drop a gold ball? Read the fairy tale "The Frog Prince," or just toss it into a pond.
- † If you locate a man wandering around the woods playing a musical instrument out of key, suggest he take up a new line of entertainment. Perhaps he'd like to be a Shakespearian actor, but for that he needs something to study.
- † Minstrels sometimes "borrow" things.
- † Pan lives in this part of the country. Not Peter Pan, but the mythological Pan. He plays a flute or pipe.
- † Try playing a duet with Pan to get his attention. Of course you'll have to get an instrument first.
- † Everyone knows flute music soothes reptiles. Better hope the reptiles know it.
- † Swimming west from the beach where you began will take you to the Good Fairy's island.
- † Sometimes Cupid hangs out around the Roman pool. If you surprise him he may leave you something.
- † The fisherman is a kindly man, but he is often too busy to notice you.
- † You might try a little fishing from the pier if you can barter for a pole, and if you have bait.

Points of Interest in East Tamir

This is the bad part of Tamir. Here live an Ogre and his family, three ugly witches, an assortment of ghouls, and some wicked trees. The only good folks on the east side are the seven dwarfs. There's much to fear in this area, so take care, especially after dark. Oh yes, a worm lives here, too.

- † There are some valuable things in the house of Mr. and Mrs. Ogre, but you'll have to hide if he comes home.
- † Knick-knack, paddy whack, give the dog a bone is a good lesson to remember.
- † Guess who lives inside the skull? It isn't the Three Bears.
- † As disgusting as it is, you're going to have to get your hands on an eye.
- † There are seven dwarfs who live in east Tamir. They are so industrious and busy they don't have time to clean up. If you're nice, they might ask you to dinner.
- † You might pick up something in the dwarves' house that could help you get a lantern. It gets dark early in Tamir.
- † There's a cave behind the waterfall, but you'll have to figure out how to get to it. Not even Mark Spitz could swim there.
- † If you thought handling an eye was bad, wait until you dig up a few putrid graves.
- † You might have to prune a tree or two along your way.
- † The haunted house is full of creepy things that go bump in the night. After dark, you need something special just to get close.
- † Check out the crypt, but only if you have a light.

☛ Points of Interest in the Haunted House ☛

- † Look at the picture in the parlor. Anyone you know?
- † There are lots of unhappy ghosts here. Each wants something that was buried with his or her body.
- † Playing the organ is a cryptic experience.
- † You've got to find a secret panel to get anywhere in this house.

☛ Points of Interest in the Swamp ☛

- † Just getting to the swamp is dangerous.
- † The cave maze is fairly simple, but you have to avoid the troll and that may be the most difficult task in this game. Patience pays off, but remember, you now have less than 24 hours.
- † There's only one way to get across the swamp, now hop to it.
- † Don't leave your bridges behind you.
- † You'll be sorry if you didn't take something from the troll cave.

Points of Interest on the ☛ Good Fairy's Island ☛

- † Actually, this island doesn't have much of interest. The only thing to see is a sick fairy.
- † You might pick up something outside the castle.
- † Swimming off this island can be an engulfing experience.
- † The only way back is to swim, so you better practice your backstroke and hope for the best.

Points of Interest in the Ocean

- † Remember Jonah and the Whale?
- † There's only one way to get out of a whale's belly: Tickle his fancy, or whatever is handy. If you don't have what it takes, you'll starve to death.
- † There's a one-palm desert island in this ocean. It has shipwrecks and some goodies.
- † Rosella! Are you still carrying that dead fish? It's beginning to stink.
- † You can't swim back to Tamir from the desert island. Others have tried and failed. You'll have to catch a ride back.
- † There's an important piece of gear on the island. Don't leave for home without it.

Points of Interest in Lolotte's Castle

- † There's no way around it; you are going to have to kill Lolotte.
- † You have only one weapon, but it seems inappropriate.
- † Edgar is a buffoon and of no help just yet. You may change your mind about him later.
- † Once Lolotte is gone, you'll have no problem with the guards.
- † Remember to return the things you "borrowed."

Points Not of Interest

Sometimes it's fun to live on the edge. Try some of these things, but only after you've saved the game.

Hug a witch

Offer to take a zombie to dinner

Try to swing in the scary trees

Look for a bottle inside the whale

Pet the cobra

Change to a frog after you get through the troll's maze and hop across the tufts of grass

Other Points of Interest (Also known as scoring)

King's Quest IV gives you points for finding and using items, and for delivering things to Lolotte. But the property you gave her was not yours, so you'll get bonus points for putting it back. If you do everything correctly, the maximum score is 230.

Maps of *King's Quest IV*

West Tamir

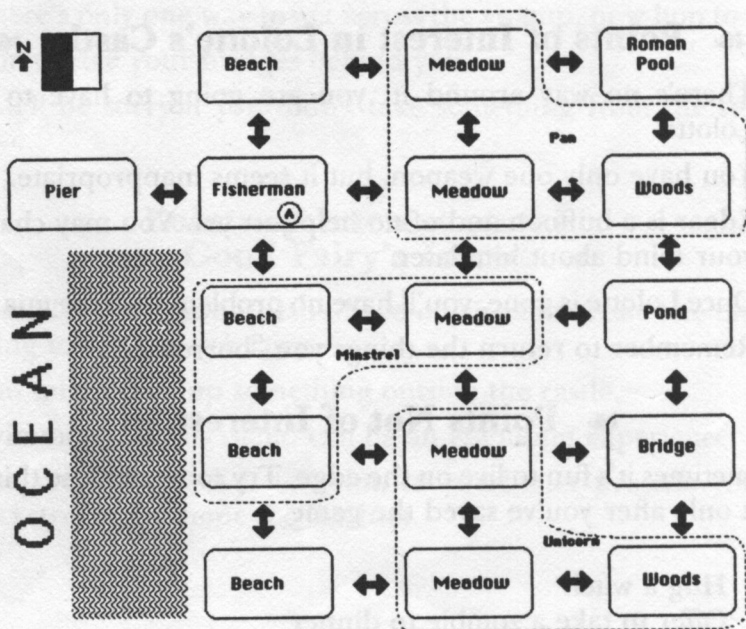

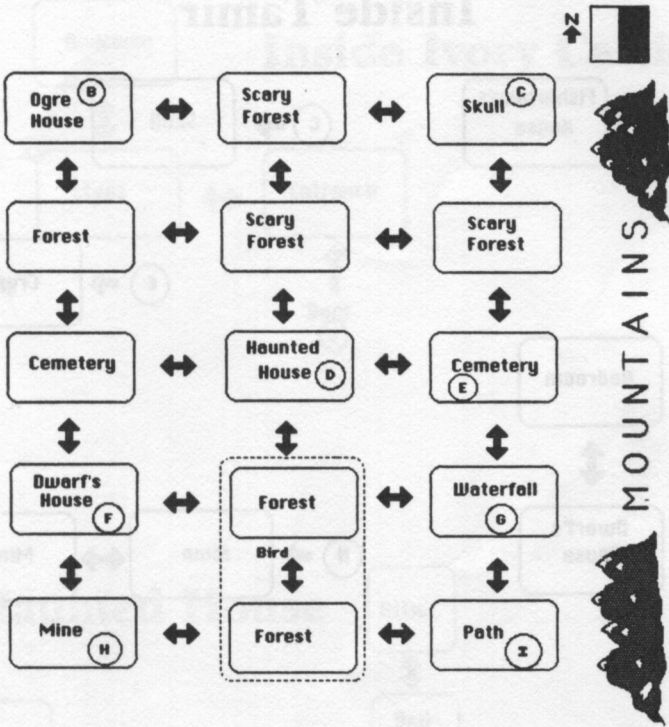

East Tamir

Inside Tamir

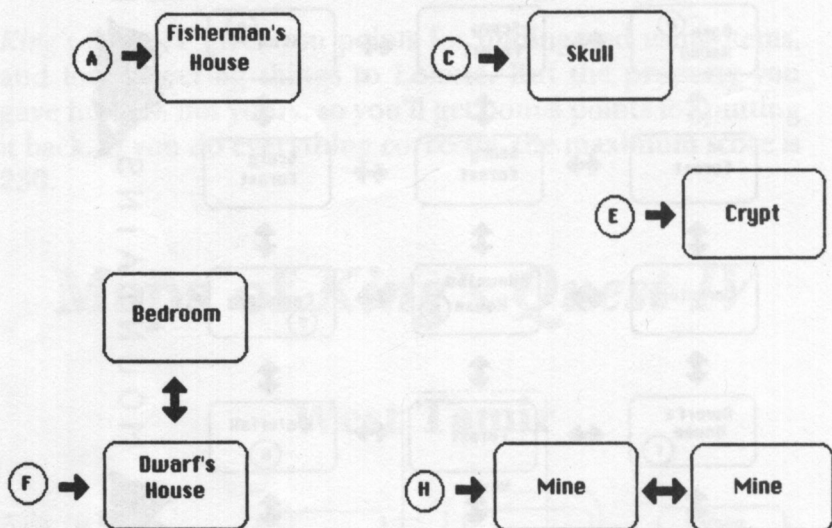

Good Fairy Island

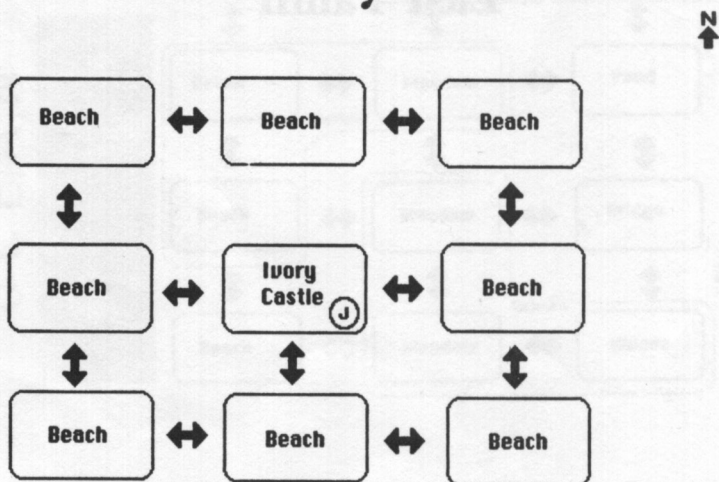

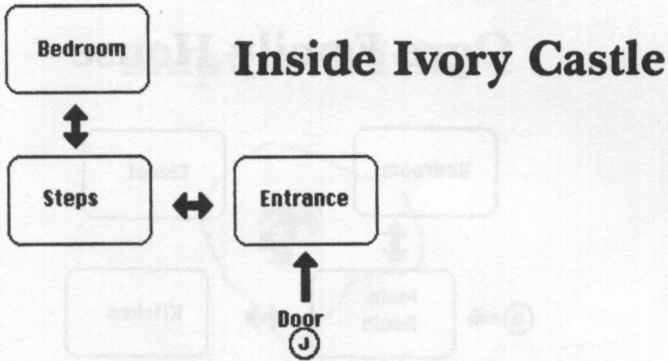

Haunted House

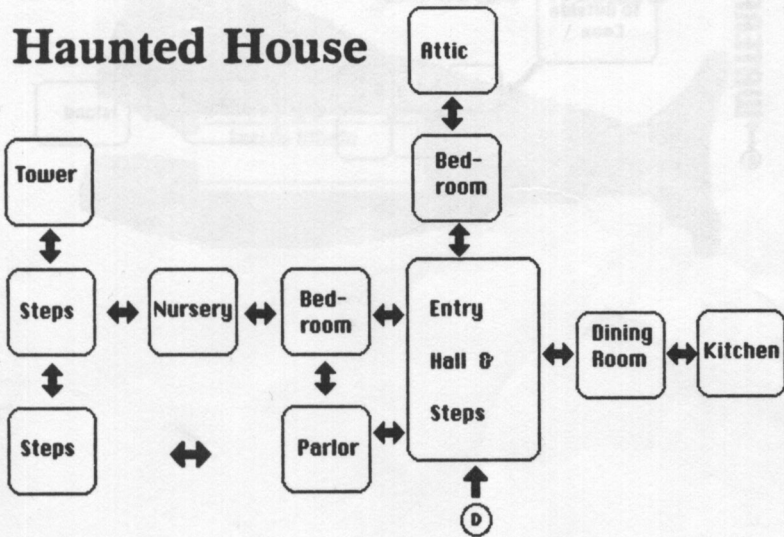

Ogre Family House

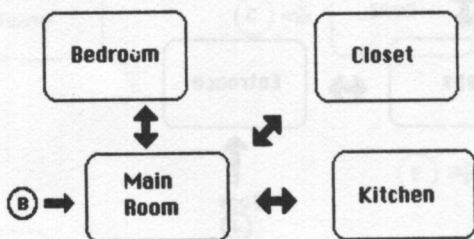

WATERFALL

Troll's Maze

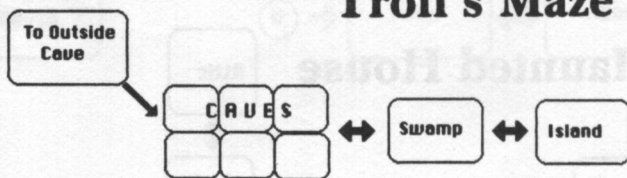

Shipwreck Island



Inside whale

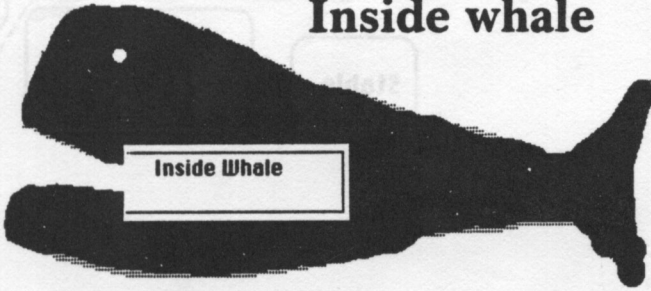

Lolotte's Castle

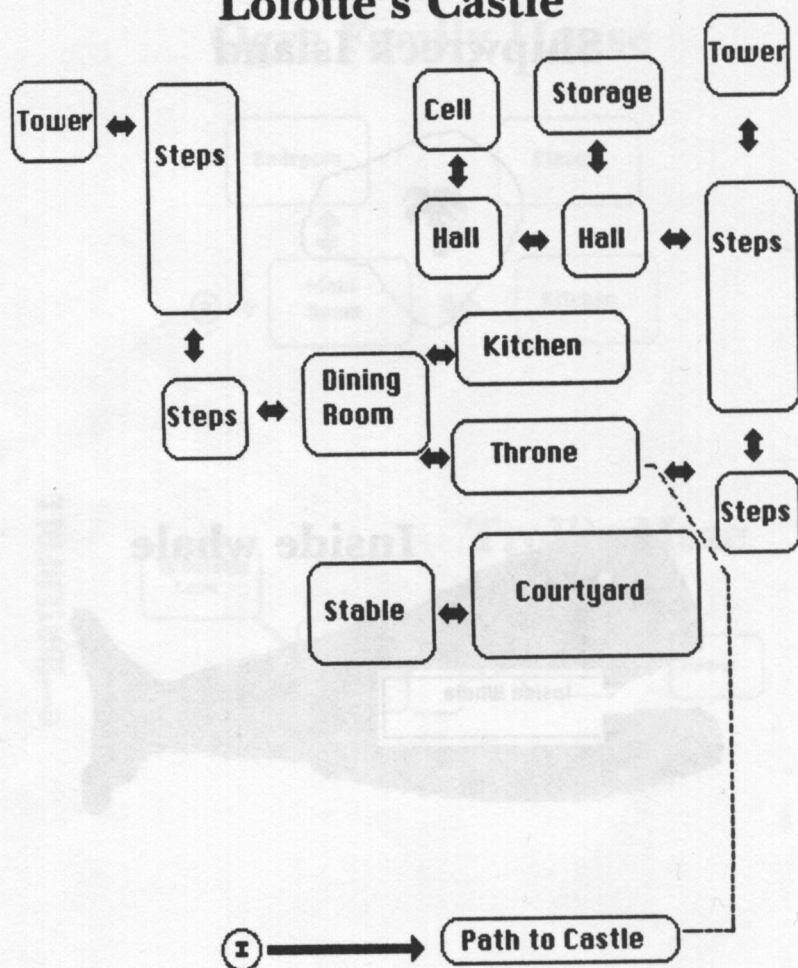

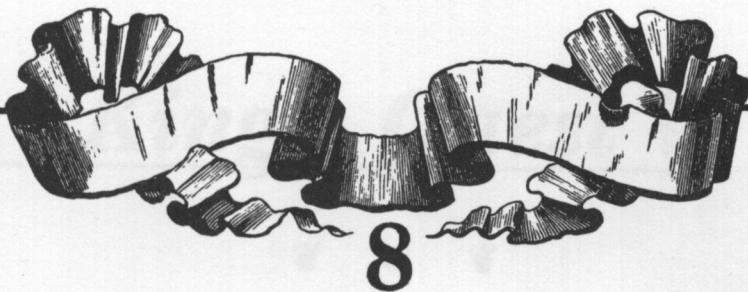

All the poor Graham family ever live happily ever
and Robert's thinking. As for me, I'm betting on a
early Edgar and Pascha wedding

KING'S QUEST V

King's Quest V



Will the poor Graham family *ever* live happily ever after? Roberta's thinking. As for me, I'm betting on an early Edgar and Rosella wedding.

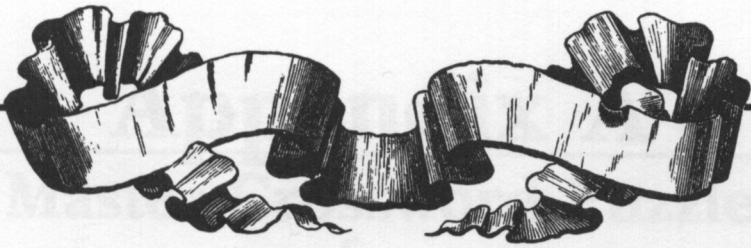

for
King's Quest I-IV

APPENDICES

- | | |
|--|--|
| 1. Answer keys for the spells of
<i>Quest I</i> | 74. A wizard's charm |
| 2. Guide to drawing <i>Quest I</i> | 75. How to recognize the <i>Quest I</i> |
| 3. Maps from <i>Quest I</i> | 76. Approximate Roman path |
| 4. Advice for beginning <i>Quest I</i> words | 77. Link to a night owl |
| 5. Day, two needed to cross water <i>Quest I</i> | 78. Good for a soldier |
| words | 79. Belongs to <i>Quest I</i> |
| 6. Maps from <i>Quest I</i> | 80. The grove's name |
| 7. Located in top of oak tree | 81. Image of day <i>Quest I</i> words |
| 8. A simple map <i>Quest I</i> words | 82. Place where spells are prepared |
| 9. Garden's hiding place | 83. Found under a rock |
| | 84. How to make whole <i>Quest I</i> words |

Appendix A

Master Crossword Puzzle for *King's Quest I-IV*

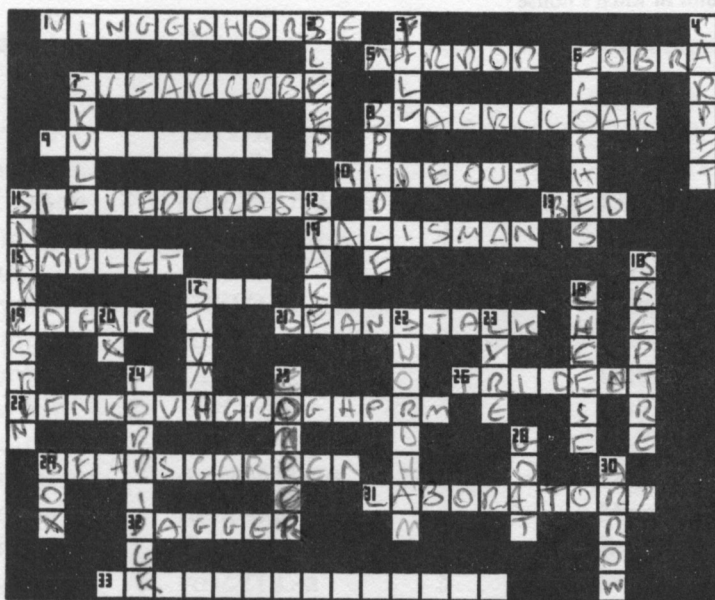

-O-D-R

Across

- | | |
|---|-------------------------------------|
| 1. Another form for the snake (2 words) | 14. A good-luck charm |
| 5. Used to destroy Medusa | 15. Key to returning to Daventry |
| 6. Guards fruit tree | 17. Appears near Roman pool |
| 7. Antidote for brambles (2 words) | 19. Lolotte's ugly son |
| 8. Disguise needed to cross water (2 words) | 21. Used for a ladder |
| 9. Magic snack food | 26. Belongs to Neptune |
| 10. Located in top of oak tree | 27. The gnome's name |
| 11. Keeps a vampire away (2 words) | 29. Source of dew (2 words) |
| 13. Gwydion's hiding place | 31. Place where spells are prepared |
| | 32. Found under a rock |
| | 33. Used to tickle whale (2 words) |

Down

- | | |
|--------------------------------------|--|
| 2. Spell used to disable the pirates | 20. Used to chop grabbing trees |
| 3. Inscription on bowl | 22. Two ways to get rid of a lion (2 words) |
| 4. Your way to top of cliffs | 23. Played by wanderiang minstrel |
| 6. Magic map is hidden behind these | 24. Substance mixed with cookie to change wizard |
| 7. Home of the three witches | 25. Form of air transportation |
| 8. Used to harness the snake | 28. Used to get rid of troll |
| 11. Ingredient found in desert | 29. Used as a step ladder in ship's hold |
| 12. Used to kill Dracula | 30. Cupid's weapon |
| 16. Belonging to leprechaun king | |
| 17. Location of diamonds | |
| 18. Found in witch's house | |

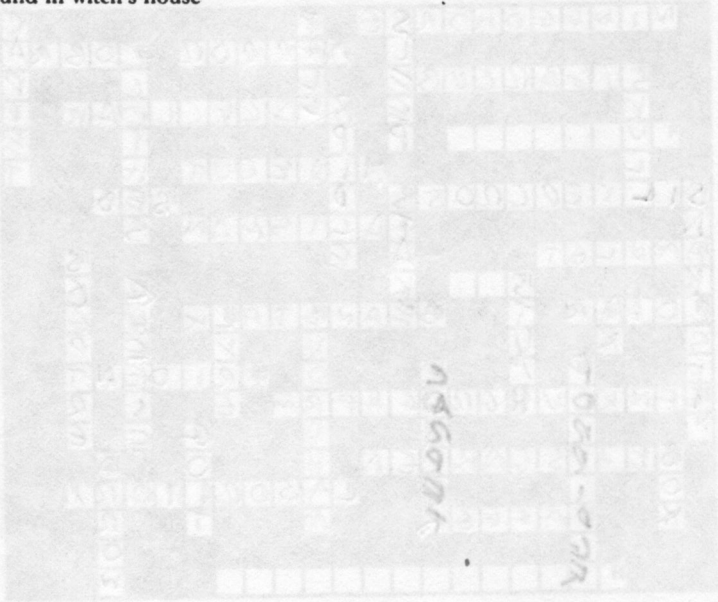

Appendix B

Pronunciation Guide to the Characters and Places of the Quests

Name	Pronounced	KQ	Description
?	?	1	Gnome
Davertry	DAV-in-tree	1,2,3,4	Country
Dracula	DRAC-u-la	2	Vampire
Enchanter	en-CHANT-ter	2	Evil person
Genesta	jen-NES-ta	4	Good Fairy
Graham	gram	1,2,3	Knight/King
Gwydion	GWID-ee-un	3	Boy
Kolyma	KO-lee-ma	2	Country
Leprechauns	LEP-ra-kahnz	2	Little People
Llewddor	LOO-dor	3	Country
Lolotte	lo-LOT	4	Bad Fairy
Manannan	ma-NAN-un	3	Wizard
Medusa	meh-DOOZ-a	3	Monster
Ogre	O-ger	2	Bad guy
Rosella	ro-ZELL-a	3	Princess
Sorcerer	SOURCE-er-er	1	Wizard
Tamir	tuh-MEER	4	Country
Valanice	VAL-a-niece	2	Princess

Appendix C

Score Values

Generally, points are earned for one of four reasons

- † Finding or getting an item
- † Using an item
- † Giving or trading an item
- † Bonus points for being polite

The descriptions of the items and activities listed below are intentionally vague, in order to give away as little as possible. For example, diving under the water earns four points, but I can't tell you into which water to dive.

The totals are the maximum you can accumulate in one game. In all cases you can successfully complete the quest with less than the total points. You might want to play a second time to see how close you can come to the maximum.

Because these descriptions, bare as they are, reveal some important clues, we've disguised them, but you can use any old magic mirror to read them.

King's Quest I

Value	Item or Activity
3	Bowing to king
3	Bowing to king later
1	Checking stump
1	Entering castle
2	Filling bucket
3	Flying
3	Getting bowl
2	Getting bucket
3	Getting carrot

3	Getting golden nugget
8	Getting magic chest
8	Getting magic mirror
8	Getting magic shield
1	Getting mushroom
2	Getting note
3	Getting nut
1	Getting pebbles
3	Getting pouch
3	Getting ring
6	Getting sceptre
2	Getting slingshot
	Getting past dragon by
5	using water
-2	killing
	Getting to clouds by
5	finding key
11	guessing gnome's name
	Getting magic chest by
2	killing giant
7	waiting
3	Giving bowl to needy
2	Giving cheese to rat
- value of	Giving up a treasure
treasure	
1	Leaving by hole
0	Getting spell from Fairy Godmother
2	Moving rock
2	Opening cupboard
7	Pushing witch into oven
1	Reading bowl
1	Reading note
1	Returning to Edward's castle
2	Swimming out of well
5	Tempting goat
4	Using goat
-2	Using magic ring by wolf, elf, etc.

158 Maximum

King's Quest II

Value	Item or Activity
2	Catching fish
2	Covering bird cage
1	Crossing bridge
3	Discarding fish
1	Eating sugar
4	Flying
3	Getting amulet
2	Getting basket
2	Getting bird cage
4	Getting bottle
7	Getting bracelet
2	Getting bridle
7	Getting brooch
2	Getting candle
2	Getting carpet
4	Getting cloak and rumpy ring
7	Getting earrings
2	Getting ham
5	Getting key to Door 1
5	Getting key to Door 2
5	Getting key to Door 3
2	Getting magic sword
2	Getting mallet
7	Getting necklace
1	Getting net
2	Getting silver cross
2	Getting silver key
2	Getting soup
2	Getting stake
2	Getting sugar cube
7	Getting tars
3	Getting trident
5	Getting Valanice
-Value of tres-	Giving 2 treasures for lamp
sure	
4	Giving basket
2	Giving poucet
2	Giving soup
-Value of tres-	Giving treasure mermaid
sure	

—Value of treasure	Giving treasure to Ghoul
sure	
7	Killing Draculas
1	Lighting candle
1	Looking in hole
—Value of treasure	Losing a treasure
sure	
1	Opening mailbox
2	Praying
2	Removing cloth
—Value of treasure	Retrieving stolen treasure
sure	
3	Returning home
1	Riding fish
2	Riding sea horse
6	Trading nightingale
1	Unlocking chest
7	Unlocking Door 1
7	Unlocking Door 2
7	Unlocking Door 3
2	Using bridge
3	Using cloak and ruby ring
4	Using ham
2	Wearing cross

185 Maximum

King's Quest III

Value	Item or Activity
2	Boarding ship
4	Entering castle
2	Escaping ship
2	Finding hideout
4	Finding hiding place
2	Finding lever
2	Finding way out of hold
2	Flying in a hole
1	Getting scores
3	Getting amber stone
1	Getting bowl

3	Getting brass key
1	Getting bread
7	Getting buried treasure
1	Getting cactus
1	Getting cat hair
1	Getting chicken feather
1	Getting cup
1	Getting cupful of ocean water
1	Getting dew
1	Getting dog hair
2	Getting eagle feather
1	Getting fish bone powder
1	Getting fish oil
1	Getting fly wings
1	Getting fruit
1	Getting knife
1	Getting lard
7	Getting magic map
4	Getting magic wand
1	Getting mandrake root
1	Getting mirror
1	Getting mistletoe
4	Getting money
1	Getting mutton
1	Getting nightshade juice
4	Getting past Mr. Yeti
2	Getting porridge
1	Getting pouch
1	Getting rose petal essence
1	Getting saffron
1	Getting salt
1	Getting shovel
1	Getting snakeskin
1	Getting spoon
1	Getting spoonful of mud
3	Getting stolen possessions
1	Getting tinsle
1	Getting toad spittle
1	Getting toadstool powder
3	Getting money for passage
7	Killing dragon
4	Killing spider
10	Preparing cookie spell
10	Preparing invisibility spell
10	Preparing magic dough spell

10	Preparing magic stone spell
10	Preparing flying spell
10	Preparing sleep spell
10	Preparing storm brew
3	Pulling rope
3	Rescuing Princess
3	Hearing bandits in tavern
12	Using cookie spell
5	Using mirror

210 Maximum

King's Quest IV

Value	Item or Activity
3	Catching fish
5	Cleaning house
2	Deliver hen
7	Deliver hen
7	Deliver Pandora's Box
10	Deliver talisman
7	Deliver unicorn
4	Finding your stolen possessions
4	Freeing unicorn
2	Getting ax
3	Getting baby rattle
3	Getting bag of coins
2	Getting board
2	Getting bone
2	Getting book
2	Getting bow and arrows
3	Getting bridle
2	Getting diamonds
2	Getting feather
3	Getting fishing pole
3	Getting flute
10	Getting fruit
3	Getting glass eye
3	Getting golden ball
2	Getting golden crown
2	Getting golden key
4	Getting hen

1	Using worm
2	Using whistle
2	Using toy horse
8	Using second arrow
2	Using rope ladder
2	Using medal
2	Using lock
2	Using gold key
4	Using fish
4	Using first arrow
5	Using feather
3	Using bridle
4	Using bone
6	Using board (all tips)
2	Using bag of coins
2	Using baby rattle
4	Using ax
2	Unlocking tower
2	Unlocking crypt
3	Swimming under waterfall
5	Riding dolphin
2	Returning glass eye
3	Returning Pandora's Box
2	Playing organ
4	Opening secret door
2	Locking crypt
3	Kissing frog
4	Hypnotize snake with flute
2	Getting worm
3	Getting toy horse
2	Getting the whistle
2	Getting talisman
2	Getting skeleton key
2	Getting shovel
2	Getting sheet music
2	Getting scars
2	Getting Pandora's Box 2nd time
4	Getting Pandora's Box
3	Getting medal
3	Getting lute
3	Getting lock
3	Getting lantern
2	Getting hen 2nd time

Appendix D

Most-Asked Questions

Following are the questions most often asked of the Sierra Customer Service hotline. Although the questions are not answered directly, the answers are awfully close, so don't read this unless all else has failed.

How do you read this? You'll need a magic mirror and patience. If you are lacking those, perhaps a bathroom mirror will do.

King's Quest I

What is the Gnome's name?

Count the number of spaces in the crossword puzzle for this answer; then make a probability what you think it is; turning the name around backward isn't it; you must turn something else around backward and use that to spell the name.

How can Graham move the large boulder?

He cannot; no human can; a dragon can and might if it were sufficient; you must arrange; what could be a barrier to it; what is the dragon more than a door; it is fire.

Graham has completed the quest; why won't the king speak to him?

You must be polite to the king; the year is a long time to be polite; you must make a gesture before you speak.

King's Quest II

Why won't the mermaid appear?

The mermaid is afraid to appear because she is afraid of the poison she has in her blood. She is afraid that if she appears, she will be killed. She is afraid that if she appears, she will be killed. She is afraid that if she appears, she will be killed.

Where is the winged horse?

His name is Pegasus. He lives in the clouds in a different form. He lives in the clouds in a different form. He lives in the clouds in a different form.

How can Graham get Valanice to go down the steps?

Even if he gets down the steps, they cannot get to the island; magic is the only thing that will get them home; if you didn't pick up something on the island before you entered the tower you are in trouble; if you didn't examine it.

King's Quest III

Where is the magic wand?

It is in the study; it is not in the desk; it is not in the bookshelf; you will have to have a key to unlock something; the key is on top of something in the bedroom.

How does Gwydion make a spell?

He goes to the table; he stands in front of the table; he opens the book to the page he needs; and then he does what he needs with a book.

Index

How does the wizard know Gwydion has been in his laboratory?

You didn't hide what you collected; you forgot to put something back where you found it; you forgot to put a book back where you found it.

King's Quest IV

How can I get off the shipwreck island?

Now set to try to swim back to shore; you must have planned in advance; if you had a whistle you could call for a sea going cap; if you had a fish you might be able to catch a whale.

How can I get to the haunted house at night?

You must have a special charm to get past the ghoul; you should be able to get a charm in a haunted house.

Why won't the unicorn follow me?

You must do something to make the unicorn want to be as near as you; but that's not enough; you must physically capture him with something you found on an island.

Index

- AGI (Adventure Game Interpreter) 16
- animation 16
- Antique Shop 59

- bulletin boards 32

- Castle of Dracula 61
 - map of 66
- characters, creation of 15-16
- chase function 18
- class of objects 17
- Clouds 62
- Colossal Cave* 5
- control lines 15
- crossword puzzles 43, 57, 73, 92-93, 111-12
- Cruise Ship 76
 - map of 87

- Daventry 41
 - in *King's Quest III* 76
 - King's Quest III* map 88
 - maps of 48-51
 - northeast points of interest 44
 - northwest points of interest 44-45
 - southwest points of interest 46
- debugging 23-24
 - routines 24
 - software 23
- debug mode 24-25
- doors 55, 58, 60-61

- Ego 14
 - changing the speed of movement of 33
- Enchanted Island 62
 - map of 67

- function 18

- Good Fairy's Island 96
 - map of 100
- Goldstein, William 20-22
- graphic adventure games
 - history of 6
 - making of 13-26
 - graphics adapter 30

- Haunted House 96
 - map of 101
- help 32-33
- hint books 33

- Ivory Castle, map of 101

- joystick 34

- King's Quest*
 - history of 7
 - installation of 31
 - versions of 29-30
- King's Quest I* 41-52
 - crossword puzzle 43
 - getting started 41-42
 - guessing the gnome's name 45, 123
 - maps 48-52
 - most-asked questions 123
 - points of interest 44-47
 - scoring 47
- King's Quest II*, 55-68
 - crossword puzzle 57
 - getting started 55
 - maps 63-68
 - most-asked questions 124
 - points of interest 58-63
 - scoring 63
- King's Quest III*, 71-88
 - crossword puzzle 72
 - getting started 71
 - maps 84-88

- most-asked questions 124–25
- points of interest 75–76, 83
- scoring 83
- King's Quest IV* 8, 91–104
 - crossword puzzle 92–93
 - getting started 91
 - making of 13–26
 - maps 98–104
 - most-asked questions 125
 - points of interest 94–98
 - scoring 98
- King's Quest V* 107
- Kingdom of Neptune 61
 - map of 66
- Kolyima 55
 - maps 63–65
 - northeast points of interest 59
 - northwest points of interest 58
 - southeast points of interest 50
 - southwest points of interest 59
- Land of the Clouds 46
 - map of 52
- Land of the Leprechauns 47
 - map of 49
- lines of instruction 20
- Llewddor 71
 - eastern points of interest 75
 - maps of 85–86
 - western points of interest 75
- Lolotte's Castle 97
 - map of 104
- memory 16
- Monastery 59
- music 20–22
- music card 21
- Mystery House* 6
- Ocean 97
- Ogre Family House, map of 102
- parser 34–35
- picture editor 14
- pixel drawings 15
- priority bands 15
 - to reveal 25
- pronunciation guide 113
- rooms 13, 20
- saving 36
- SCI (Script Interpreter) 16–17
- scoring 47
 - values 115–21
- screens 41, 55
- Sierra On-Line 6–9
- Snowy Mountains 76
 - map of 88
- spells 73–82
- STATUS command 35
- Swamp 96
- SYSOP 32
- taking 34–35
- talking 34–35
- Tamir 91–92
 - eastern points of interest 95
 - maps of 98–100
 - western points of interest 94
- teleportation 24
- testing the game 22–23
- Time Zone* 7
- Troll's Maze, map of 102
- view editor 14
- Williams, Roberta and Ken 6–9
- Wizard's House 74
 - map of 84
- ZAP command 24



Oakhurst, California, located south of Yosemite National Park, is the home of Sierra On-Line. (Photo courtesy of Larry Owens)



In 1988 the Sierra staff moved into this new building nestled in mountains near the Sierra National Forest. (Photo courtesy of Bob Ballew)



The King's Quest IV team. Left to right, standing: Chris Hoyt, Ken Koch, Carolly Hauksdottir, Chane Fullmer, Jeff Stephenson, Eileen Fisher-Stewart, Robert E. Heitman, Teresa Baker; left to right, sitting: John Hamilton, Roberta Williams, William Skirvin. (Photo courtesy of Larry Owens)



Ken Koch and Chane Fullmer, both SCI programmers, discuss a change with Roberta. (Photo courtesy of Larry Owens)

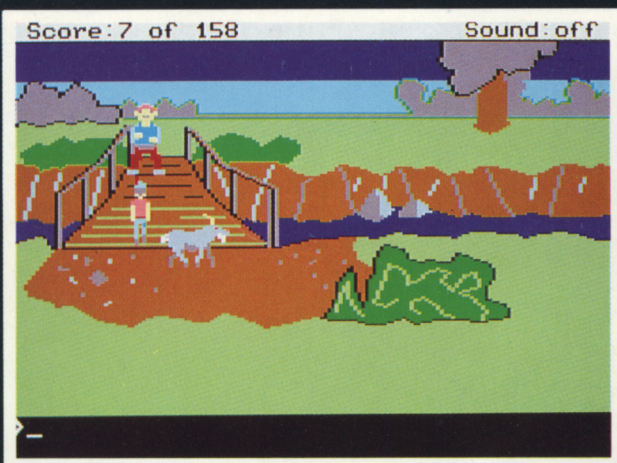

A fierce troll guards the bridge to an isolated island in King's Quest I as Graham approaches, followed by his pet goat. (Photo courtesy of Jerry Albright)

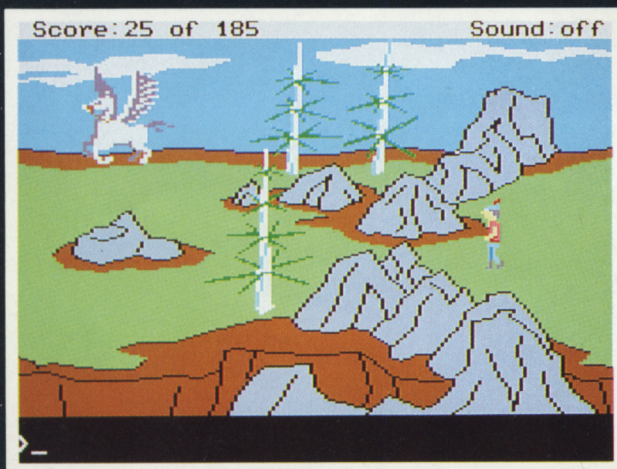

Pegasus, a winged horse, flies about the Land of the Clouds in King's Quest II. With the right equipment and a little skill, Graham turns a dangerous situation to his advantage. (Photo courtesy of Jerry Albright)

Score: 5 of 210 0:07:44 Sound: on



Gwydion looks high and low for the wizard's magic wand in King's Quest III. He must have it in order to cast spells. (Photo courtesy of Jerry Albright)



Artist William Skirvin uses a PC and a mouse to work on the Fisherman's Shack in King's Quest IV while Roberta looks on. Skirvin was responsible for creating the initial layouts for many of the King's Quest IV scenes. (Photo courtesy of Larry Owens)

1001:Line U:8 P:A C:0 X=249 Y=89 Pri:5

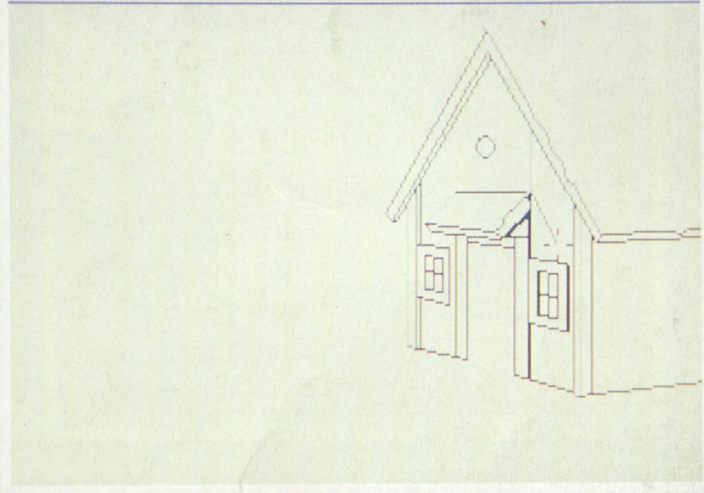

This sequence of photographs from King's Quest IV shows how the Fisherman's Shack is developed. First the artist produces a simple line drawing from a rough sketch. (Photo courtesy of Jerry Albright)

1001:Fill U:B P:0 C:B X=96 Y=99 Pri:6

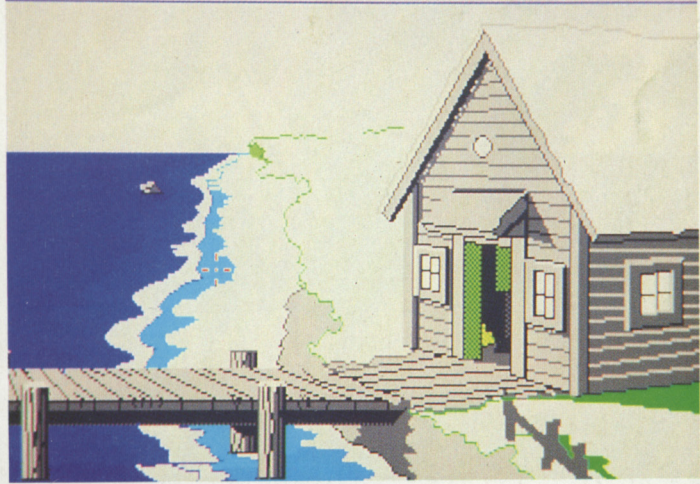

Color is added to surfaces; in this case the shack is colored gray. Note how shade and shadow begin to give a three-dimensional effect. (Photo courtesy of Jerry Albright)

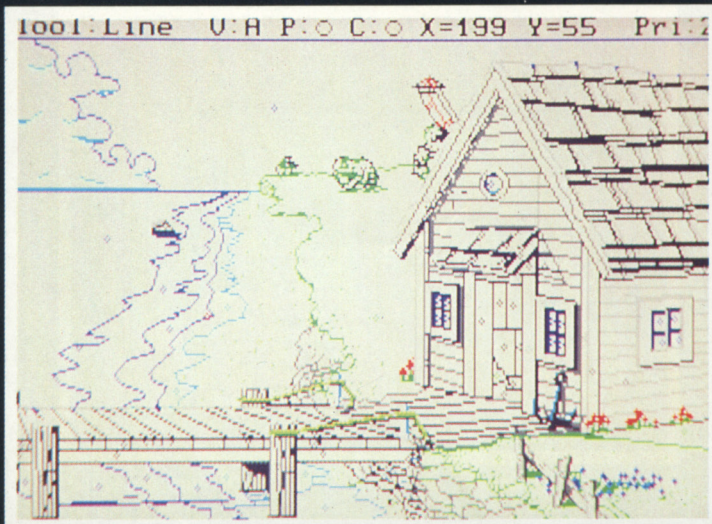

Using a keystroke command, the artist removes solid colors to add small details like flowers, bushes, and rocks. (Photo courtesy of Jerry Albright)

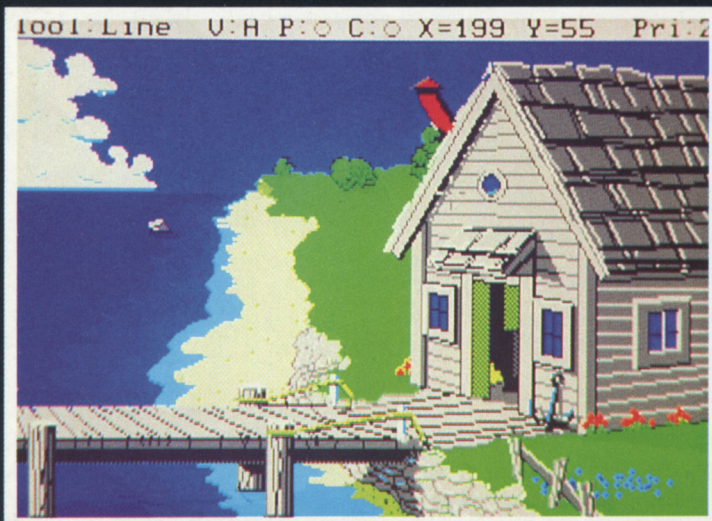

The screen is almost finished. Only a few details need to be added. Note the rope fence; it was needed to fix a programming bug that allowed Ego to fall over the edge of the cliff. (Photo courtesy of Jerry Albright)

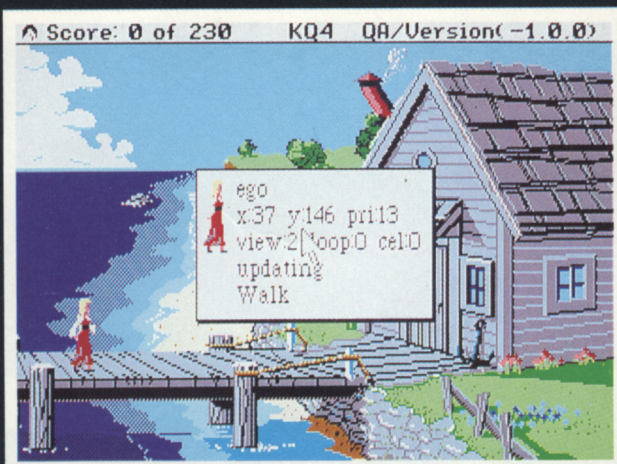

This is the finished screen. The window in the middle is used by the programmers to display Ego's activities and coordinates as she moves about the room. (Photo courtesy of Jerry Albright)

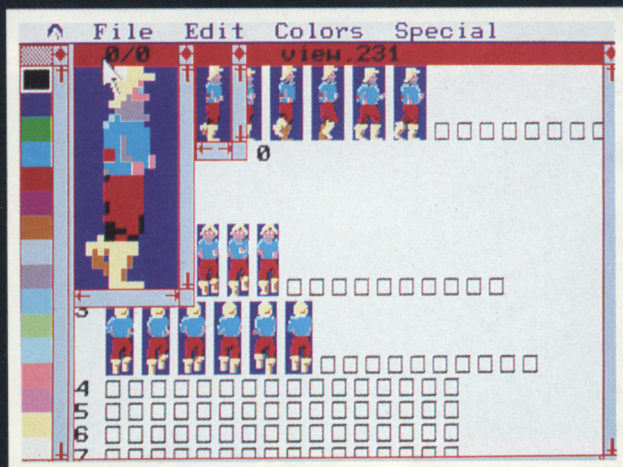

The artist uses windows and pull-down menus in the animation program to create figures that seem to move. (Photo courtesy of Jerry Albright)

1001:Line U:H P:O U:O X=199 Y=55 Pri

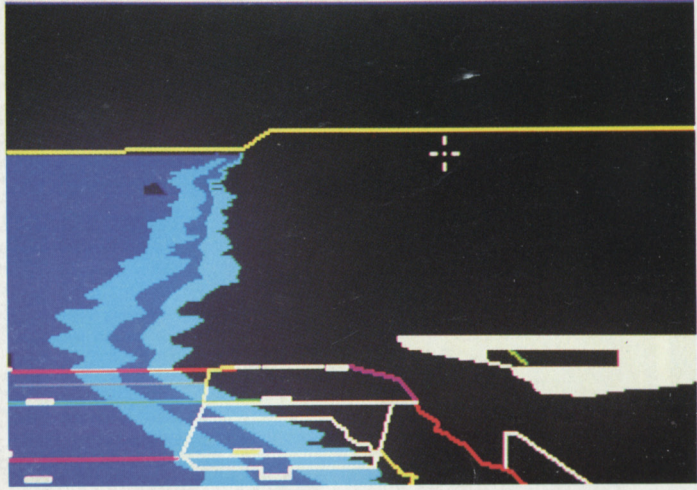

The control lines that govern where characters can walk are invisible in the finished product, but can be displayed with the debugging commands. (Photo courtesy of Jerry Albright)

1001:Line U:H P:O U:O X=199 Y=55 Pri

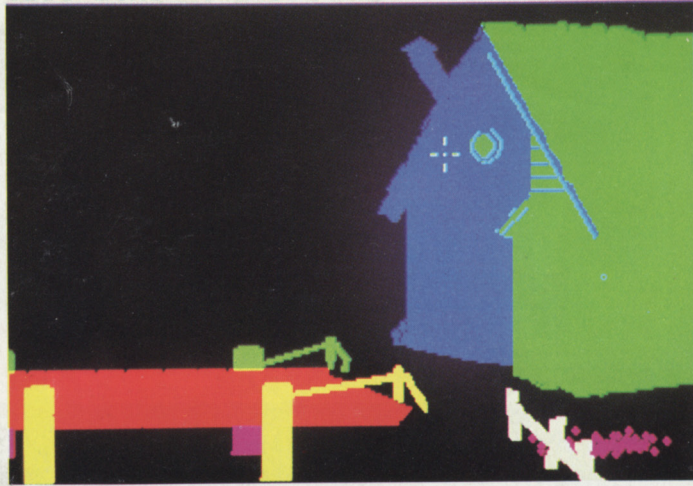

The priority bands appear as different colors and determine whether an object appears in front of or behind another object. Nothing may appear in front of white, which has the highest priority. (Photo courtesy of Jerry Albright)

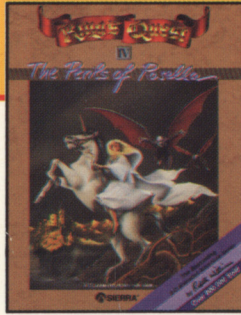

• The Royal Road to King's Quest •

The Official Book of King's Quest: Daventry and Beyond is the official, authorized guide to *King's Quest*, from Sierra On-Line. *King's Quest* is America's most popular series of 3-D animated adventure games. This book will help you puzzle out the answers to some of the most nagging enigmas in this series of action/adventure games.

The Official Book of King's Quest: Daventry and Beyond provides an insider's view of Sierra On-Line, the genius factory that produces *King's Quest*. *King's Quest* is a series of games made up of equal parts mythology, history, fantasy, and thrilling adventure. This book is full of revealed secrets. Did you know, for example, that special software—hidden code and secret commands—was left in some versions of *King's Quest*?

You'll see how the games are designed from the first notes by creator Roberta Williams, through programming, composition, animation, and debugging.

The creation of a successful adventure game is an adventure itself. But that's only the beginning. The second part of this book is for people who need help completing the quests. Inside you'll find

- † Foreword by Roberta Williams, *King's Quest* creator
- † Maps of Daventry and beyond
- † How the games are put together
- † Hints, tips, and clues
- † The Sierra On-Line story
- † Inside information
- † Ways to add even more fun to *King's Quest*

The Official Book of King's Quest: Daventry and Beyond is the book for which every *King's Quest* aficionado and devotee has been waiting.

\$10.95

Higher in Canada

ISBN 0-87455-155-2



9 780874 551556