

Hayt & Kemmerly

ENGINEERING CIRCUIT ANALYSIS

international student edition

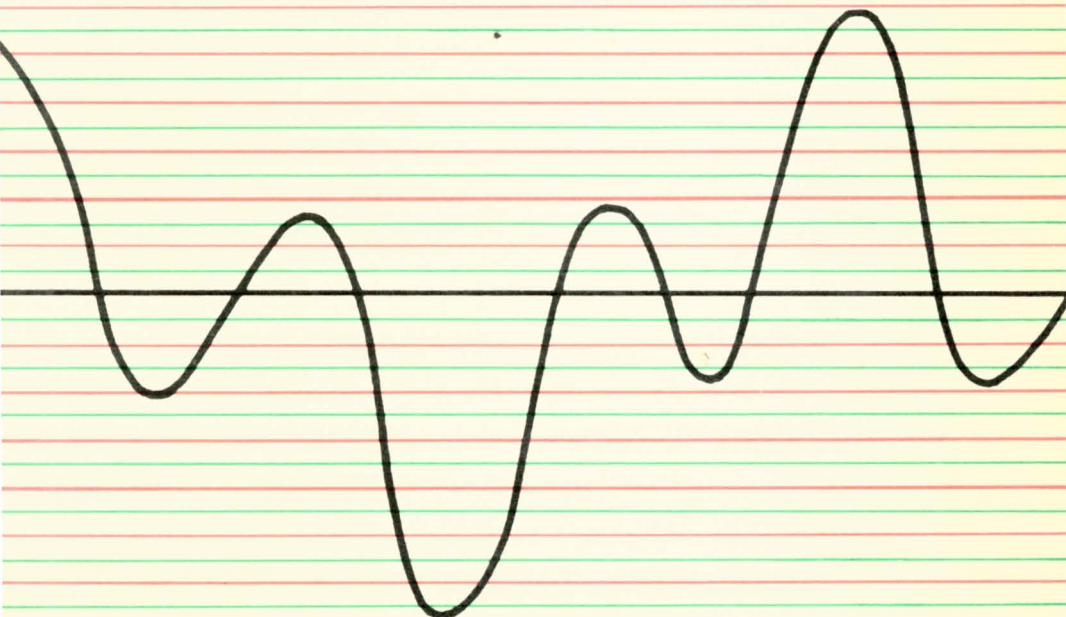

ENGINEERING CIRCUIT ANALYSIS

McGraw-Hill Electrical and Electronic Engineering Series

FREDERICK EMMONS TERMAN, *Consulting Editor*

W. W. HARMAN and J. G. TRUXAL, *Associate Consulting Editors*

- AHRENDT and SAVANT ♦ *Servomechanism Practice*
ANGELO ♦ *Electronic Circuits*
ASELTINE ♦ *Transform Method in Linear System Analysis*
ATWATER ♦ *Introduction to Microwave Theory*
BAILEY and GAULT ♦ *Alternating-current Machinery*
BERANEK ♦ *Acoustics*
BRENNER and JAVID ♦ *Analysis of Electric Circuits*
BROWN ♦ *Analysis of Linear Time-invariant Systems*
BRUNS and SAUNDERS ♦ *Analysis of Feedback Control Systems*
CAGE ♦ *Theory and Application of Industrial Electronics*
CAUER ♦ *Synthesis of Linear Communication Networks*
CHEN ♦ *Linear Network Design and Synthesis*
CHEN ♦ *The Analysis of Linear Systems*
CHIRLIAN and ZEMANIAN ♦ *Electronics*
CLEMENT and JOHNSON ♦ *Electrical Engineering Science*
COTE and OAKES ♦ *Linear Vacuum-tube and Transistor Circuits*
CUCCIA ♦ *Harmonics, Sidebands, and Transients in Communication Engineering*
CUNNINGHAM ♦ *Introduction to Nonlinear Analysis*
EASTMAN ♦ *Fundamentals of Vacuum Tubes*
EVANS ♦ *Control-system Dynamics*
FEINSTEIN ♦ *Foundations of Information Theory*
FITZGERALD and HIGGINBOTHAM ♦ *Basic Electrical Engineering*
FITZGERALD and KINGSLEY ♦ *Electric Machinery*
FRANK ♦ *Electrical Measurement Analysis*
FRIEDLAND, WING, and ASH ♦ *Principles of Linear Networks*
GEPPERT ♦ *Basic Electron Tubes*
GHOSE ♦ *Microwave Circuit Theory and Analysis*
GREINER ♦ *Semiconductor Devices and Applications*
HAMMOND ♦ *Electrical Engineering*
HANCOCK ♦ *An Introduction to the Principles of Communication Theory*
HAPPELL and HESSELBERTH ♦ *Engineering Electronics*
HARMAN ♦ *Fundamentals of Electronic Motion*
HARMAN ♦ *Principles of the Statistical Theory of Communication*
HARMAN and LYTLE ♦ *Electrical and Mechanical Networks*
HARRINGTON ♦ *Introduction to Electromagnetic Engineering*
HARRINGTON ♦ *Time-harmonic Electromagnetic Fields*
HAYT ♦ *Engineering Electromagnetics*
HILL ♦ *Electronics in Engineering*
HUELSMAN ♦ *Circuits, Matrices, and Linear Vector Spaces*
JAVID and BRENNER ♦ *Analysis, Transmission and Filtering of Signals*
JAVID and BROWN ♦ *Field Analysis and Electromagnetics*
JOHNSON ♦ *Transmission Lines and Networks*
KOENIG and BLACKWELL ♦ *Electromechanical System Theory*
KRAUS ♦ *Antennas*
KRAUS ♦ *Electromagnetics*
KUH and PEDERSON ♦ *Principles of Circuit Synthesis*
LEDLEY ♦ *Digital Computer and Control Engineering*
LE PAGE ♦ *Analysis of Alternating-current Circuits*

LE PAGE and SEELY ♦ *General Network Analysis*
LEY, LUTZ, and REHBERG ♦ *Linear Circuit Analysis*
LINVILL and GIBBONS ♦ *Transistors and Active Circuits*
LYNCH and TRUXAL ♦ *Introductory System Analysis*
LYNCH and TRUXAL ♦ *Principles of Electronic Instrumentation*
LYNCH and TRUXAL ♦ *Signals and Systems in Electrical Engineering*
MILLMAN ♦ *Vacuum-tube and Semiconductor Electronics*
MILLMAN and SEELY ♦ *Electronics*
MILLMAN and TAUB ♦ *Pulse and Digital Circuits*
MISHKIN and BRAUN ♦ *Adaptive Control Systems*
MOORE ♦ *Traveling-wave Engineering*
NANAVATI ♦ *An Introduction to Semiconductor Electronics*
PETTIT ♦ *Electronic Switching, Timing, and Pulse Circuits*
PETTIT and MC WHORTER ♦ *Electronic Amplifier Circuits*
PFEIFFER ♦ *Linear Systems Analysis*
REZA ♦ *An Introduction to Information Theory*
REZA and SEELY ♦ *Modern Network Analysis*
ROGERS ♦ *Introduction to Electric Fields*
RYDER ♦ *Engineering Electronics*
SCHWARTZ ♦ *Information Transmission, Modulation, and Noise*
SEELY ♦ *Electromechanical Energy Conversion*
SEELY ♦ *Electron-tube Circuits*
SEELY ♦ *Electronic Engineering*
SEELY ♦ *Introduction to Electromagnetic Fields*
SEELY ♦ *Radio Electronics*
SEIFERT and STEEG ♦ *Control Systems Engineering*
SIEGMAN ♦ *Microwave Solid State Masers*
SISKIND ♦ *Direct-current Machinery*
SKILLING ♦ *Electric Transmission Lines*
SKILLING ♦ *Transient Electric Currents*
SPANGENBERG ♦ *Fundamentals of Electron Devices*
SPANGENBERG ♦ *Vacuum Tubes*
STEVENSON ♦ *Elements of Power System Analysis*
STEWART ♦ *Fundamentals of Signal Theory*
STORER ♦ *Passive Network Synthesis*
STRAUSS ♦ *Wave Generation and Shaping*
TERMAN ♦ *Electronic and Radio Engineering*
TERMAN and PETTIT ♦ *Electronic Measurements*
THALER ♦ *Elements of Servomechanism Theory*
THALER and BROWN ♦ *Analysis and Design of Feedback Control Systems*
THALER and PASTEL ♦ *Analysis and Design of Nonlinear Feedback Control Systems*
THOMPSON ♦ *Alternating-current and Transient Circuit Analysis*
TOU ♦ *Digital and Sampled-data Control Systems*
TRUXAL ♦ *Automatic Feedback Control System Synthesis*
VALDES ♦ *The Physical Theory of Transistors*
VAN BLADEL ♦ *Electromagnetic Fields*
WEINBERG ♦ *Network Analysis and Synthesis*
WILLIAMS and YOUNG ♦ *Electrical Engineering Problems*

WILLIAM H. HAYT, JR.

Professor of Electrical Engineering, Purdue University

JACK E. KEMMERLY

*Space Systems Operation, Aeronutronic Division, Ford Motor Company
(Formerly Associate Professor of Electrical Engineering, Purdue University)*

**McGRAW-HILL BOOK COMPANY, INC.
KÔGAKUSHA COMPANY, LTD.**

ENGINEERING CIRCUIT ANALYSIS

INTERNATIONAL STUDENT EDITION

*New York St. Louis San Francisco London Mexico Panama Sydney Toronto
Tokyo*

ENGINEERING CIRCUIT ANALYSIS

INTERNATIONAL STUDENT EDITION

Exclusive rights by Kōgakusha Co., Ltd., for manufacture and export from Japan. This book cannot be re-exported from the country to which it is consigned by Kōgakusha Co., Ltd., or by McGraw-Hill Book Company, Inc., or any of its subsidiaries.

v

Copyright © 1962 by the McGraw-Hill Book Company, Inc. All rights reserved. This book, or parts thereof, may not be reproduced in any form without permission of the publishers.

Library of Congress Catalog Card Number: 62-17882

Preface

This book is intended for use with a first course in electrical engineering. In many colleges and universities such a course will be preceded or accompanied by an introductory physics course in which the basic concepts of electricity and magnetism are introduced, most often from the field aspect. Such a background is not a prerequisite, however. Circuit elements are introduced and defined here in terms of their circuit equations; only incidental comments are offered about the pertinent field relationships. Several of the basic concepts of electricity and magnetism are discussed (or reviewed) in the first chapter.

It is the authors' intention that this text be one from which a student may teach himself; it is written to the student and not to the instructor. Each new term is clearly defined when it is first introduced, if at all possible. The basic material appears toward the beginning of each chapter and is explained carefully and in detail; numerical examples are usually used to introduce and suggest general results. Drill problems appear at the end of most sections; they are generally simple, and the answers are given in random order. The more difficult problems which appear at the end of the chapters are in the order of presentation of the text material. These problems are occasionally used to introduce less important or more advanced topics through a guided step-by-step procedure, as well as to introduce topics which will appear in the following chapter. The introduction and resulting repetition are both important to the learning process. The problems indicated by the symbol \blacklozenge are particularly suitable for self-study and are answered at the end of the book. In all, there are 264 drill problems, each consisting of three parts, 277 problems with complete or partial answers, and 341 other problems at the end of the chapters, or 382 problems in all.

The general order of the material has been selected in order that the student may learn as many of the techniques of circuit analysis as possible in the simplest context, namely, the resistive circuit. The extension of these techniques to more advanced circuits affords the opportunity both for review and generalization. Numerous examples and problems are possible since the solutions are not mathematically involved. This first part of the text may be covered in three to six weeks, depending upon the students' background and ability, and upon the course intensity.

The second section of the text is devoted to the natural response, and the complete response to d-c excitation, of the simpler RL, RC, and RLC circuits. Differential and integral calculus are necessary, but a background in differential equations is not required. The unit step is introduced as an important singularity function; the unit impulse is the subject of an isolated chapter which may be omitted, if desired, since further applications of the unit impulse are almost entirely restricted to problems at the end of subsequent chapters.

The third part of the text introduces the frequency domain and initiates operations with complex numbers by concentrating on sinusoidal analysis, but the complete response of sinusoidally excited circuits is used to tie together the material of the preceding two parts.

In the fourth part of the book, the complex frequency concept is introduced, and its use in relating the forced response and the natural response is emphasized.

The fifth part begins with a consideration of magnetic coupling, which is basically a two-port phenomenon, and logically leads into a consideration of two-port network analysis and an introductory discussion of topology. The concluding chapters are devoted to polyphase circuits and Fourier analysis.

It is felt that the material is more than adequate for a two-semester course, but some selection may be made from the final four chapters, and the chapter on the unit impulse may be omitted. No material is included in the text which will not be of some value in the following term; operational methods, signal-flow graphs, the relationship of circuit theory to field theory, and advanced topologic concepts are subjects which are relegated to subsequent courses. The goal is the student's ability to write correct circuit equations for any circuit and his ability to solve the less complex cases and to understand the solutions.

The only justification which the authors can offer for presenting another introductory circuits book is that of an improved pedagogy. There are no startling new developments, no drastically different approaches, and no full-color three-dimensional illustrations. There is, however, a logical trail leading from definition, through explanation, description, illustration, and numerical example, to problem-solving ability and to the obvious expectation of the

Preface

authors that the student continuously ask himself, "Why does this happen? How is it related to last week's work? Where do we logically go next?" There is a tremendous amount of enthusiastic momentum in a beginning electrical engineering student, or in any student beginning a study of electrical circuits early in his college life, and this may be preserved by providing frequent drill problems whose successful solution confirms the student's progress in his own mind, by integrating the various sections into a coherent whole, by pointing out future applications and more advanced techniques, and by maintaining an interested, inquisitive attitude in the student.

Approximately 90 per cent of the material in the text has been taught successfully at Purdue University over a period of three years as a two-semester course having two lectures, two recitation-problem periods, and one laboratory or laboratory-preparation period each week.

WILLIAM H. HAYT, JR.

JACK E. KEMMERLY

Contents

Preface

vii

PART ONE: THE RESISTIVE CIRCUIT

1 Definitions and Units **2**

1-1 Introduction 1-2 Systems of Units 1-3 Mechanical Units
1-4 The Unit of Charge 1-5 Current, Voltage, and Power
1-6 Types of Circuits and Circuit Elements

2 Experimental Laws and Simple Circuits **23**

2-1 Introduction 2-2 Ohm's Law 2-3 Kirchhoff's Laws
2-4 Analysis of a Single-loop Circuit 2-5 The Single Node-pair
Circuit 2-6 Resistance and Source Combination 2-7 Voltage and
Current Division

3 Some Useful Techniques of Circuit Analysis **55**

3-1 Introduction 3-2 Mesh Analysis 3-3 Determinants
3-4 Nodal Analysis 3-5 Source Transformations 3-6 Linearity
and Superposition 3-7 Thévenin's and Norton's Theorems

PART TWO: THE TRANSIENT CIRCUIT

4 Inductance and Capacitance **104**

4-1 Introduction 4-2 The Inductor 4-3 Integral Relationships
for the Inductor 4-4 The Capacitor 4-5 Kirchhoff's Laws and
the Circuit Equations Again 4-6 Duality 4-7 Linearity and
Superposition Again 4-8 Thévenin's and Norton's Theorems

5 Source-free RL and RC Circuits **144**

5-1 Introduction 5-2 The Simple RL Circuit 5-3 Properties of the Exponential Response 5-4 A More General RL Circuit
5-5 The Simple RC Circuit 5-6 A More General RC Circuit
5-7 General RL and RC Circuits

6 The Application of the Unit-step Forcing Function **173**

6-1 Introduction 6-2 The Unit-step Forcing Function 6-3 A First Look at the Driven RL Circuit 6-4 The Natural and the Forced Response 6-5 RL Circuits 6-6 RC Circuits

7 The Unit Impulse and Its Applications **201**

7-1 Introduction 7-2 Definition of the Unit Impulse 7-3 The Current Impulse 7-4 The Voltage Impulse 7-5 The Use of Impulses to Represent Initial Values 7-6 Response in Circuits Containing Impulse Sources

8 The RLC Circuit **229**

8-1 Introduction 8-2 The Source-free Parallel Circuit 8-3 The Overdamped Parallel RLC Circuit 8-4 Critical Damping
8-5 The Underdamped Parallel RLC Circuit 8-6 The Source-free Series RLC Circuit 8-7 The Complete Response of the RLC Circuit

PART THREE: SINUSOIDAL ANALYSIS

9 The Sinusoidal Forcing Function **265**

9-1 Introduction 9-2 Characteristics of Sinusoids 9-3 Forced Response to Sinusoidal Forcing Functions

10 The Phasor Concept **277**

10-1 Introduction 10-2 The Complex Number 10-3 Euler's Identity 10-4 The Exponential Form 10-5 The Polar Form
10-6 Powers and Roots 10-7 The Complex Forcing Function
10-8 The Phasor 10-9 Phasor Relationships for R, L, and C
10-10 Impedance 10-11 Admittance

11 The Sinusoidal Steady-state Response **316**

11-1 Introduction 11-2 Mesh and Nodal Analysis
11-3 Superposition 11-4 Source Transformations
11-5 Thévenin's and Norton's Theorems 11-6 Phasor Diagrams

12 Average Power and RMS Values **338**

12-1 Introduction 12-2 Instantaneous Power 12-3 Average Power 12-4 Use of the Wattmeter 12-5 Effective Values of Current and Voltage 12-6 Apparent Power and Power Factor 12-7 Complex Power

PART FOUR: COMPLEX FREQUENCY

13 The Exponential Forcing Function **368**

13-1 Introduction 13-2 Steady-state Response to Exponential Forcing Functions 13-3 Response as a Function of σ 13-4 Response as a Function of ω

14 Complex Frequency **393**

14-1 Introduction 14-2 Complex Frequency 14-3 A Further Interpretation of Complex Frequency 14-4 The Damped Sinusoidal Forcing Function 14-5 $\mathbf{Z}(s)$ and $\mathbf{Y}(s)$ 14-6 The Complex-frequency Plane 14-7 Natural Response and the s Plane

15 Frequency Response **430**

15-1 Introduction 15-2 Immittance Loci 15-3 Further Considerations of Immittance Loci 15-4 Parallel Resonance 15-5 Series Resonance 15-6 Other Resonant Forms 15-7 Scaling

PART FIVE: SPECIAL TOPICS

16 Magnetically Coupled Circuits **481**

16-1 Introduction 16-2 Mutual Inductance 16-3 Energy Considerations 16-4 The Air-core Transformer 16-5 The Ideal Transformer

17 Two-port Networks **516**

17-1 Introduction 17-2 Minors and Cofactors 17-3 One-port Networks 17-4 Admittance Parameters 17-5 Some Equivalent Networks 17-6 Impedance Parameters 17-7 Hybrid Parameters

18	Network Topology	547
	<i>18-1 Introduction</i>	
	<i>18-2 Some Topological Definitions</i>	
	<i>18-3 Writing Independent Loop Equations</i>	
	<i>18-4 Writing Independent Nodal Equations</i>	
	<i>18-5 The Choice between Loop and Nodal Methods</i>	
19	Polyphase Circuits	568
	<i>19-1 Introduction</i>	
	<i>19-2 Single-phase Three-wire Systems</i>	
	<i>19-3 Two-phase Three-wire Systems</i>	
	<i>19-4 Three-phase Y-Y Connection</i>	
	<i>19-5 The Delta (Δ) Connection</i>	
	<i>19-6 Power Measurement in Three-phase Systems</i>	
20	Fourier Analysis	599
	<i>20-1 Introduction</i>	
	<i>20-2 Trigonometric Form of the Fourier Series</i>	
	<i>20-3 The Use of Symmetry</i>	
	<i>20-4 Complete Response to Periodic Forcing Functions</i>	
	<i>20-5 Complex Form of the Fourier Series</i>	
	<i>20-6 The Fourier Integral</i>	
	<i>20-7 Operational Methods of Circuit Analysis</i>	
	<i>Answers</i>	629
	<i>Index</i>	641

ENGINEERING CIRCUIT ANALYSIS

Part
One:
The
Resistive
Circuit

Chapter **I** *Definitions and Units*

1-1 INTRODUCTION

Ten or fifteen years ago, an introductory textbook on electric-circuit analysis would have begun with a description of the electrical engineer's place in science and industry, his glorious achievements of the past, and the lucrative and challenging life ahead. Now, however, it is becoming increasingly common for students of mechanical engineering, civil engineering, chemical engineering, and other engineering curricula, as well as an occasional student of mathematics or physics, to study introductory circuit analysis with the electrical engineer. As a matter of fact, courses in beginning circuit analysis are now being taken by engineering students before they have become identified with a particular branch of engineering.

If we have already entered or intend to enter an electrical engineering program, then circuit analysis simply represents the introductory course in our chosen field. If we are associated with some other branch of engineering, then circuit analysis may represent a large fraction of our total study of electrical engineering, but it also enables us to continue our electrical work in electronics, instrumentation, and other areas. Most important, however, is the possibility given to us to broaden our educational base and become more informed members of a team which may be primarily concerned with the development of some electrical device or system. Effective communication within such a team can be achieved only if the language and definitions used are familiar to all.

Few of the engineering accomplishments of the recent past can be credited to a single individual. The era of the Edison-type inventor has passed, and a graduating engineer should expect to become part of a group consisting of many kinds of engineers, applied mathematicians, and physicists. The group effort will be coordinated by technically trained managers, and the technical products will be produced, sold, and often operated and maintained by men having scientific or engineering training. The engineering graduates of today are

not all employed solely to work on the technical design aspects of engineering problems.

In order to contribute to the solution of these engineering problems, an engineer must acquire many skills, one of which is a knowledge of electric-circuit analysis.

We shall begin this study by considering systems of units, dimensions, and a few basic definitions and conventions in this first chapter. For those who have no knowledge of basic electricity and magnetism, the elementary subject material is included in this chapter. It should be rapid reading for anyone having an adequate background in introductory physics, but it should be read carefully by all. After these introductory topics have been mastered, we can then turn our attention to a simple electric circuit.

1-2 SYSTEMS OF UNITS

We must first establish a common language. Engineers cannot communicate with one another in a meaningful way unless each term used is clear and definite. It is also true that little learning can be achieved from a textbook which does not define carefully each new quantity as it is introduced. If we speak in the vague generalities of a television commercial—"gets clothes up to 40 per cent whiter"—and do not bother to define whiteness or to provide units by which it may be measured, then we shall certainly not succeed in engineering, although we might sell a lot of soap.

In order to state the value of some measurable quantity, we must give both a *number* and a *unit*, such as "3 inches." Fortunately we all use the same number system and know it well. This is not as true for the units, and some time must be spent in becoming familiar with a suitable system of units. We must agree on a standard unit and be assured of its permanence and its general acceptability. The standard unit of length should not be defined in terms of the distance between two marks on a certain rubber band; this is not permanent, and furthermore everybody else is using another standard.

We shall also need to define each technical term at the time it is introduced, stating the definition in terms of previously defined units and quantities. Here the definition cannot always be as general as the more theoretically minded might wish. For instance, it will soon be necessary to define "voltage." We must either accept a very complete and general definition, which we can neither appreciate nor understand now, or else adopt a less general but simpler definition which will satisfy our purposes for the present. By the time a more general definition is needed, our familiarity with the simpler concepts will help our understanding at that time.

It will also become evident that many quantities are so closely related to each other that the first one defined needs a few subsequent definitions before it can be thoroughly understood. As an example, when the "circuit element" is defined it is most convenient to define it in terms of "current" and "voltage," and when current and voltage are defined, it is helpful to do so with reference

to a circuit element. None of these three definitions can be well understood until all have been stated. Therefore, our first definition of the circuit element may be somewhat inadequate, but then we shall define current and voltage in terms of a circuit element and finally go back and define a circuit element more carefully. A study of electromagnetic theory should provide us with a more general definition of both current and voltage.

We have very little choice open to us with regard to a system of units. The one which we shall use has been adopted by all the major professional electrical engineering societies, it is used consistently throughout the electrical engineering journals, and it is the language in which today's textbooks are written. This is the rationalized mks (meter-kilogram-second) system of units introduced by G. Giorgi in 1902.

The three fundamental units, the meter, the kilogram, and the second, were defined by a commission of French scientists in the late 1700s. At that time it was their intention that the meter be exactly one ten-millionth of the distance from the earth's pole to its equator. This distance was marked off by two fine lines on a platinum-iridium bar which had been cooled to zero degrees centigrade. Although more accurate surveys have shown since that the marks on the bar do not represent this fraction of the earth's meridian accurately, the distance between the marks was accepted internationally as the definition of the standard meter until 1960. In that year, an international commission defined the meter as 1,650,763.73 times the wavelength of radiation of the orange line of krypton 86. The definitions are equivalent, but the newer definition is much more permanent.

The fundamental unit of mass, the kilogram, was defined as the mass of a platinum block located with the meter bar at the International Bureau of Weights and Measures in Sèvres, France. The mass of this block is approximately equal to one thousand times the mass of one cubic centimeter of pure water at 4°C.

The third fundamental unit, the second, was first defined as 1/86,400 of a mean solar day. At the present time, it is defined as 1/31,556,925.9747 of the tropical year 1900. The two definitions were exactly equivalent in 1956.

There are several advantages which are inherent in the rationalized mks system of units. One is embodied in the word "rationalized," which signifies that a factor of 4π has been eliminated from several important equations by incorporating it within two constants, the permittivity and permeability of free space. Since these equations appear in more advanced work, and the constants themselves appear only rarely in circuit theory, it is relatively unimportant to us now whether or not our system of units is rationalized.

The second advantage lies in the use of the decimal system to relate larger and smaller units to the fundamental unit. Thus, every unit in the rationalized mks system is related to its fundamental unit by some power of 10. Furthermore, standardized prefixes have been adopted to signify these various powers. The more common ones are: pico- (p-, 10^{-12}), nano- (n-, 10^{-9}), micro- (μ -, 10^{-6}), milli- (m-, 10^{-3}), centi- (c-, 10^{-2}), deci- (d-, 10^{-1}), deka- (dk-, 10^1), hekto- (h-, 10^2), kilo- (k-, 10^3), mega- (M-, 10^6), giga- (G-, 10^9), and tera- (T-, 10^{12}).

Thus, a millisecond (msec) is one-thousandth of a second and a kilometer (km) is one thousand meters. It is apparent now that the gram was originally established as the fundamental unit of mass, and the kilogram then represented merely one thousand grams. Now the kilogram is our fundamental unit, and we could describe the gram as a millikilogram if we wished to be confusing. Combinations of several prefixes may also be used, such as the millimicrosecond, but the term nanosecond is preferred.

This power-of-10 relationship is not present in the so-called British system of units which is in common use in this country. There are many occasions when the results of an engineering analysis must be transformed into the British system of units for use in the shop or for clarity in discussions with others. Most of us have a better mental picture of two inches than we do of five centimeters.

The fundamental British units are defined in terms of the rationalized mks units as follows: one yard is exactly $3600/3937$ meters, one pound (mass) is 0.453593 kilogram, and the second is common to both systems.

[NOTE: Throughout the text, drill problems appear following sections in which a new principle is introduced, in order to allow the student to test his understanding of the basic fact itself. The problems are useful in gaining familiarization with new terms and ideas and should all be worked. More general problems appear at the ends of the chapters. The answers to the drill problems are given in random order. For example, in Drill Prob. 1-1, the answers are (a) 3.94, (b) 0.15, and (c) 1.80.]

Drill Problem

1-1 Find the ratio of the first quantity of each pair to the second: (a) a length of 1 decimeter and a length of 1 inch; (b) a mass of 3×10^5 micrograms and a mass of 0.002 kilogram; (c) a time of 1 hour and a time of 2×10^6 milliseconds.

Ans. 0.15; 3.94; 1.80

1-3 MECHANICAL UNITS

We now have the three fundamental units, the meter, the kilogram, and the second, which are used to measure the three quantities, length, mass, and time. Before we meet our first electrical quantity and define the unit with which it is to be measured, it is necessary to consider several additional mechanical quantities and the units in which each is measured. In order to do this, dimensional symbolism will be introduced.

The quantities mass, length, and time are assigned the dimensional symbols $[M]$, $[L]$, and $[T]$. The dimensional symbol of a new quantity may be obtained from the quantity's defining formula, neglecting all dimensionless multiplying constants and derivative and integral signs; any formula will do. Thus, whether we define velocity as the quotient of distance and time $v = x/t$ or as the rate of change of distance with respect to time $v = dx/dt$, substitution of the correct symbols for distance and time leads to the dimensional symbol for velocity $[LT^{-1}]$. Area has the dimensional symbol $[L^2]$, indicating the units of meters

squared. The dimensional symbol is not a formula; it contains no constants, and the symbol for area is the same whether we are considering a circle or a square.

The use of dimensional symbolism will enable us to check the dimensions of each side of an equation and quickly uncover any careless errors we may have made. It will also provide us with a clearer picture of the significance of new combinations of familiar quantities. For example, several chapters from now the product of the two quantities electrical resistance and capacitance will begin to appear frequently, and the use of dimensional symbols will show immediately that the dimensional symbol of the product is $[T]$. Thus this product is measured in seconds, and we should then expect to find a physical interpretation in terms of some descriptive time interval.

Now let us consider several other mechanical quantities which will concern us and then describe their units and dimensional symbols. Acceleration is defined as the time rate of change of velocity and has the units meters per second per second $[LT^{-2}]$. No special name is given to this unit or to the unit of velocity.

The basic unit of force, however, has been termed the newton, which is one meter-kilogram per second per second $[MLT^{-2}]$. The dimensional symbol may be checked by using dimensional symbols in Newton's third law, $F = ma$. One newton is equivalent to 0.22481 pound of force or to 10^5 dynes, a unit in the cgs (centimeter-gram-second) system of units. The average nineteen-year-old male has a mass of 68 kilograms and exerts a force of 670 newtons on the scales.

The basic unit of work or energy is the joule, defined as one newton-meter $[ML^2T^{-2}]$. The application of a constant force of one newton through a distance of one meter requires an energy expenditure of one joule. This same amount of energy is required to lift this book, weighing about ten newtons, a distance of about ten centimeters. The joule is equivalent to 10^7 ergs, another cgs unit, or to 0.73756 foot-pound.

The last mechanical quantity with which we shall concern ourselves is power, the rate at which work is done or energy expended. The basic unit of power is the watt, one joule per second, $[ML^2T^{-3}]$. One watt is equivalent to 1/745.7 horsepower, 10^7 ergs per second, or 0.73756 foot-pound per second.

Drill Problem

1-2 Determine the average power, in watts, required to: (a) raise a weight of $\frac{1}{2}$ lb a distance of 2 ft in 10 sec; (b) expend 1 erg every microsecond; (c) accelerate a neutron ($m = 1.67 \times 10^{-27}$ kg) to 1 per cent of the velocity of light in 0.0001 nanosec.

Ans. 0.1 watt; 0.0752 watt; 0.1357 watt

1-4 THE UNIT OF CHARGE

Before beginning a discussion of electricity and electric circuits, we may define the class of electrical phenomena which we are going to consider in terms of an analogy. When we hold a baseball out at arm's length and release it, we know that it falls toward the earth because of the gravitational force exerted on

it. We can also describe precisely *how* it accelerates, *what* its velocity is at any given instant, *when* it reaches a given point, and *where* it will be at a given instant. Few of us understand, however, *why* it falls. Although we understand very well what gravitational forces do, we do not know what they are.

In an analogous way, an electrical engineer is very familiar with the forces, meter deflections, heating effects, and other measurable responses caused by electricity, but he is only rarely concerned with the theoretical (and philosophical) nature of electricity itself. Therefore, our goal is a competence in observing electrical phenomena, describing them mathematically, and putting them to a practical use. We shall be only incidentally concerned with their cause.

Suppose that we take a small piece of some light material such as pith and suspend it by a fine thread. If we now rub a hard rubber comb with a woolen cloth and then touch the pith ball with the comb, we find that the pith ball tends to swing away from it; a force of repulsion exists between the comb and the pith ball. After laying down the comb and then approaching the pith ball with the woolen cloth, we can see that there is a force of attraction present between the pith ball and the woolen cloth.

We explain both of these forces on the pith ball by saying that they are *electrical* forces caused by the presence of *electrical charges* on the pith ball, the comb, and the woolen cloth. In an analogous way, we attribute the force on the baseball to a *gravitational* force caused by the presence of gravitational masses in the baseball and the earth. The reason for each force is unknown, but its existence is very familiar.

Our experiment shows clearly that the electrical force may be one of either attraction or repulsion, and in this respect the gravitational analogy breaks down. As far as we know at the present time, a gravitational repulsive force does not exist.

We explain the existence of an electrical force of both attraction and repulsion by the hypothesis that there are two kinds of charge and that like charges repel and unlike charges attract. The two kinds of charge are called positive and negative, although we might have called them gold and black or vitreous and resinous (as they were termed many years ago). Arbitrarily, the type of charge originally present on the comb was called negative by Benjamin Franklin, and that on the woolen cloth, positive.

We may now describe our experiment in these new terms. By rubbing the comb with the cloth, a negative charge is produced on the comb and a positive charge on the cloth. Touching the pith ball with the comb transferred some of its negative charge to the pith ball, and the force of repulsion between the like kinds of charge on the pith ball and comb caused the ball to move away. As we brought the positively charged woolen cloth near the negatively charged pith ball, a force of attraction between the two different kinds of charge was evident.

We also know now that all matter is made up of fundamental building blocks called atoms and that the atoms, in turn, are composed of different kinds of fundamental particles. The three most important particles are the electron, the proton, and the neutron. The electron possesses a negative charge, the proton possesses an equal-magnitude positive charge, and the neutron is neutral, or has

no charge at all. As we rubbed the rubber comb with the woolen cloth, the comb acquired its negative charge because some of the electrons on the wool were rubbed off onto the comb; the cloth then had an insufficient number of electrons to maintain its electrical neutrality and thus behaved as a positive charge.

The mass of each of the three particles named above has been determined experimentally and is 9.1083×10^{-31} kg for the electron and about 1840 times as large for the proton and the neutron.

Now we are ready to define the fundamental unit of charge, called the coulomb after Charles Coulomb, the first man to make careful quantitative measurements of the force between two charges. The coulomb can, of course, be defined in any way we wish as long as the definition is convenient, universally accepted, permanent, and does not contradict any previous definition. Again, this leaves us no freedom at all because the definition which is already universally accepted is as follows: two small, identically charged particles which are separated one meter in a vacuum and repel each other with a force of $10^{-7}c^2$ newtons possess an identical charge of either plus or minus one coulomb. The symbol c represents the velocity of light, 2.99796×10^8 m/sec. In terms of this unit, the charge of an electron is a negative 1.60206×10^{-19} coulomb, and one coulomb (negative) therefore represents the combined charge of about 6.24×10^{18} electrons.

We shall symbolize charge by Q or q ; the capital letter is reserved for a charge which does not change with time, or is a constant, and the lower-case letter represents the general case of a time-varying charge. We often call this the *instantaneous* value of the charge and may emphasize its time dependence by writing it as $q(t)$. This same use of capital and lower-case letters will be carried over to all other electrical quantities as well. The dimensional symbol for charge is $[Q]$.

Drill Problem

- 1-3 How many electrons constitute a charge of: (a) -10^8 μ coulombs?
 (b) -10^{-16} megacoulomb? (c) -10^{-6} mcoulomb?

Ans. 6.24×10^8 ; 6.24×10^8 ; 6.24×10^9

1-5 CURRENT, VOLTAGE, AND POWER

The electrical phenomena discussed above belong to the field of electrostatics, which is concerned with the behavior of electric charges at rest. This is of interest to us only because it is a beginning and serves as a useful device to define charge.

One part of the experiment, however, departed from electrostatics, the process of transferring charge from the wool cloth to the comb or from the comb to the pith ball. This idea of "transfer of charge" or "charge in motion" is of vital importance to us in studying electric circuits, because, in moving a charge from place to place, we may also transfer energy from one point to another. The familiar cross-country power transmission line is a practical example.

Of equal importance is the possibility of varying the rate at which the charge is transferred in order to communicate or transfer intelligence. This process is the basis of communication systems such as radio, television, and telemetry.

Charge in motion represents a *current*, which we shall define more carefully below. Current, flowing along a discrete path, such as a metallic wire, has both a magnitude and a direction associated with it; it is a measure of the rate at which charge is moving past a given reference point in a specified direction. We shall study the process of measuring and defining this rate by an example.

Let us consider a discrete path along which charge can move and ask a number of questions about the manner in which charge is traveling along this lead or conductor. As a first-hand observer, we shall place a very small student at point *A* on the path and ask him to record the total amount of charge which has passed him since some reference time $t = 0$. We ask that he take data every second¹ and then give him these detailed instructions:

1. The positive direction is to your right.
2. If positive charge moves past you in the positive direction, add the magnitude of the charge.
3. If positive charge moves in the negative direction, subtract the charge magnitude.
4. If negative charge moves in the positive direction, also subtract the charge magnitude.
5. If negative charge moves in the negative direction, add the charge magnitude.

The observer watches for 8 sec, records his data, and then hands us the graph, Fig. 1-1, explaining that q is the total charge which has moved past him since $t = 0$.

Now we see that there are many ways in which this record might be interpreted. For instance, in the first second either one unit positive charge moved by to the left or one negative charge moved past to the right. The same alternative is present for the second 1-sec interval. As a matter of fact, in either of these intervals the observer might have had to count 100 unit positive charges moving to the right and 101 moving to the left. Perhaps positive and negative charges were in motion in both directions.

It is fortunate that we do not need to know which specific one of this infinite number of possibilities actually occurred; the electrical effects produced by each will be the same.

We now refine the data by making measurements much more often, and this requires that smaller and smaller elements of charge be counted. The limit is the amount of charge carried by a single electron. The graphical record now appears as a smooth curve, Fig. 1-2.

We are now ready to consider the *rate* at which charge is being transferred. In the time interval extending from t to $(t + \Delta t)$, the charge transferred past the reference point has increased from q to $(q + \Delta q)$. If the graph is decreasing at this instant, then Δq is a negative value. The rate at which charge is passing

¹ He is a small, *quick* student.

10 *The Resistive Circuit*

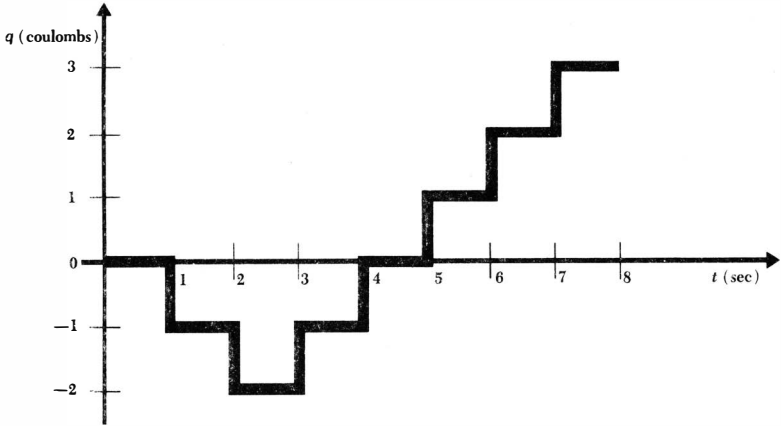

Fig. 1-1 A graph of the total charge q which has passed a given reference point since $t = 0$. The charge is measured over 1-sec intervals.

the reference point at time t is therefore very closely equal to $\Delta q/\Delta t$, and as the interval Δt decreases, the exact value of the rate is given by the derivative

$$\frac{dq}{dt} = \lim_{\Delta t \rightarrow 0} \frac{\Delta q}{\Delta t}$$

We define the current at a specific point and flowing in a specified direction as the instantaneous rate at which positive charge is moving past that point in the specified direction. Current is symbolized by I or i , and thus

$$i = \frac{dq}{dt} \quad \text{amp}$$

where an ampere is one coulomb per second [QT^{-1}]. The use of the lower-case letter i is again to be associated with an instantaneous value. Using the data of Fig. 1-2, the instantaneous current is given by the slope of the curve at every point. This current is plotted in Fig. 1-3.

The charge may be found from the current by integrating. Since

$$i = \frac{dq}{dt}$$

then

$$q = \int i \, dt$$

The total charge transferred between time t_0 and t may be expressed as a definite integral,

$$q = \int_{t_0}^t i \, dt$$

11 Definitions and Units

Several different types of current are illustrated in Fig. 1-4. A current which is constant is termed a direct current, or simply d-c, and is shown by Fig. 1-4a. We shall find many practical examples of currents which vary sinusoidally with time, Fig. 1-4b; currents of this form are present in the normal household circuits. Such a current is often referred to as alternating current, or a-c. Exponential currents and damped sinusoidal currents, sketched in Fig. 1-4c and d, will also be encountered later.

We establish a graphical symbol for current by using a closed arrowhead on the conductor. Thus, in Fig. 1-5a the direction of the arrowhead and the value "+3 amp" indicate *either* that a net positive charge of 3 coulombs/sec is moving to the right or that a net negative charge of minus 3 coulombs is moving to the left each second. In Fig. 1-5b there are again two possibilities: either minus 3 coulombs/sec is flowing to the left or plus 3 coulombs/sec is flowing to the right. All four of these statements and both figures represent currents which are equivalent in their electrical effects, and we say that they are equal.

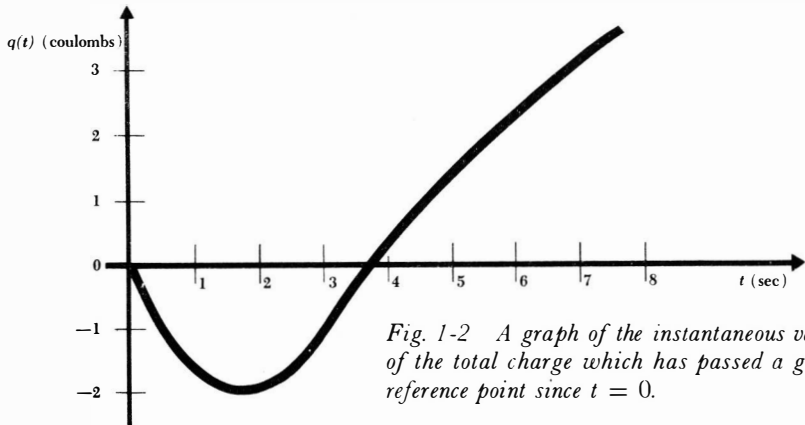

Fig. 1-2 A graph of the instantaneous value of the total charge which has passed a given reference point since $t = 0$.

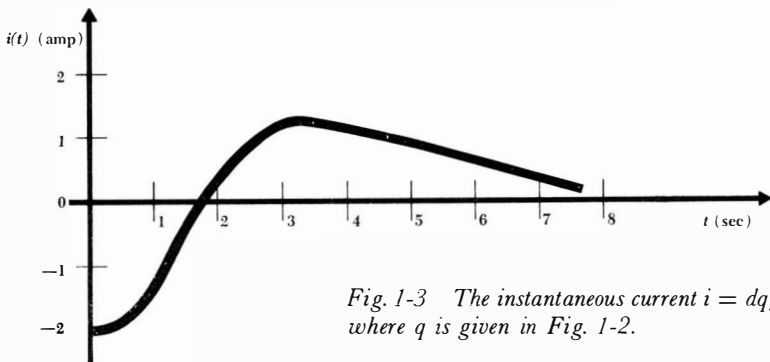

Fig. 1-3 The instantaneous current $i = dq/dt$, where q is given in Fig. 1-2.

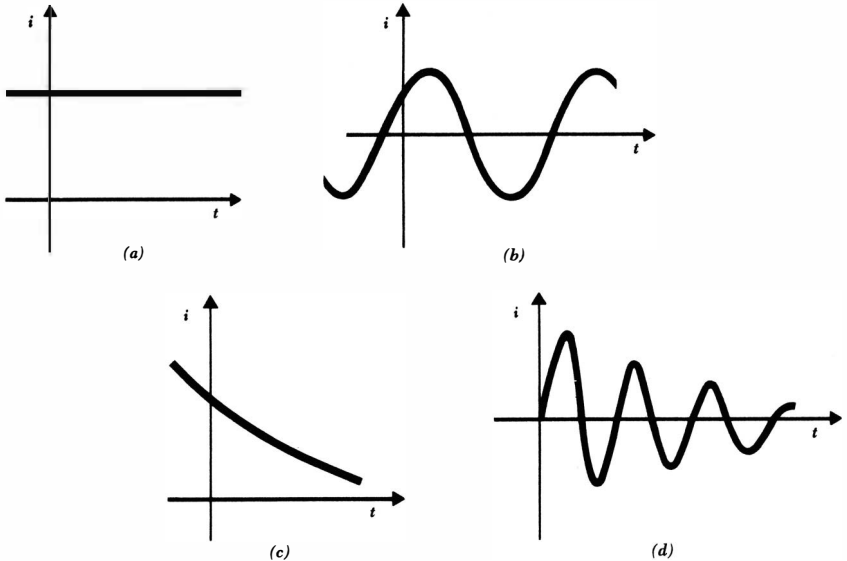

Fig. 1-4 Several types of current: (a) direct current, or d-c; (b) sinusoidal current, or a-c; (c) exponential current; (d) damped sinusoidal current.

It is convenient to think of current as the motion of positive charge even though it is known that current flow in metallic conductors results from electron motion. In ionized gases, in electrolytic solutions, and in some semiconductor materials, positively charged elements in motion constitute the current. Thus, any definition of current can agree only with the physical nature of conduction part of the time. The definition and symbolism we have adopted are standard.

We must next define a circuit element. Such electrical devices as fuses, light bulbs, resistors, batteries, capacitors, generators, and spark coils can be represented by combinations of simple circuit elements. We shall begin by showing a very general circuit element as a shapeless object possessing two terminals at which connections to other elements may be made, Fig. 1-6. This simple picture may serve as the definition of a general circuit element. There is one path through which current may flow into the element and a second through which current may flow out of the element. Later we shall define particular circuit elements by describing the electrical characteristics which may be observed at their pairs of terminals.

Let us suppose that direct current is flowing into terminal *A* of Fig. 1-6,



Fig. 1-5 Two methods of representation for the same current.

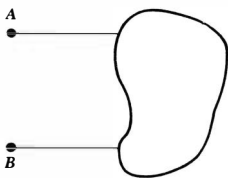

Fig. 1-6 A general circuit element is characterized by a pair of terminals to which other general circuit elements may be connected.

through the general element, and out of B . Let us also assume that the passage of this charge through the element requires an expenditure of energy. We then say that an electrical *voltage* or a *potential difference* exists between the two terminals, or that there is a voltage or potential difference “across” the element. Thus, the voltage across a terminal pair is a measure of the work required to move charge through the element. Specifically, we shall define the voltage across the element as the work required to move a positive charge of one coulomb from one terminal through the device to the other terminal. The sign of the voltage will be discussed below. The unit of voltage is the *volt*, which is one joule per coulomb [$ML^2T^{-2}Q^{-1}$], and voltage is represented by E or e .

The energy which is expended in forcing the charges through the element must appear somewhere else by the principle of conservation of energy. When we later meet specific circuit elements, we should note whether the energy is stored in some form which is readily available or whether it changes irreversibly into heat.

We must now establish a convention by which we can distinguish between energy supplied to the element by some external source and energy which may be supplied by the element itself to some external device. We do this by our choice of a sign for the voltage of terminal A with respect to terminal B . If a positive current is flowing into terminal A of the element and if an external source must expend energy to establish this current, then terminal A is positive with respect to terminal B . Alternatively, we may say also that terminal B is negative with respect to terminal A .

The sense of the voltage is indicated graphically by an open-headed arrow. In Fig. 1-7a the voltage arrowhead is located at terminal A , and thus terminal A is e volts positive with respect to terminal B . If we later find that e happens to be minus 5 volts, then we may say either that A is minus 5 volts positive with respect to B or that B is 5 volts positive with respect to A . Other cases are shown and described in Fig. 1-7b, c, and d.

No statement can be made concerning energy transfer in any of these four cases until the direction of current flow is specified. Let us assume that a current arrow is placed on each upper lead, directed to the right, and labeled “+2 amp”; then, since in both cases c and d terminal A is 5 volts positive with respect to terminal B and since a positive current is entering terminal A , energy is being supplied to the element. In the remaining two cases, the element is delivering energy to some external device.

We have already defined power, and we shall represent it by P or p . If one joule of energy is expended in transferring one coulomb of charge through the

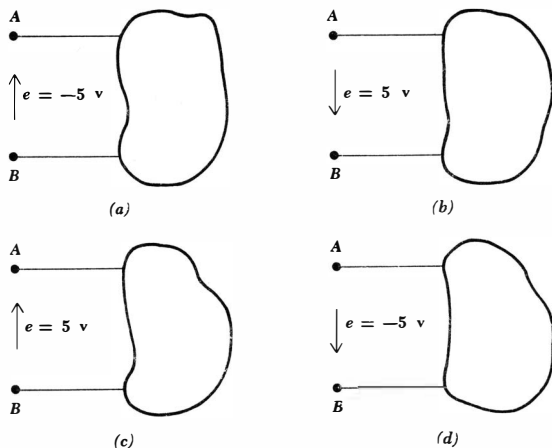

Fig. 1-7 In (a) and (b), terminal B is 5 volts positive with respect to terminal A; in (c) and (d), terminal A is 5 volts positive with respect to terminal B.

device, then the rate of energy expenditure in transferring one coulomb of charge per second through the device is one watt. The power must be proportional both to the number of coulombs transferred per second, or current, and to the energy needed to transfer one coulomb through the element, or voltage. Thus,

$$p = ei \quad \text{watt}$$

and dimensional symbolism may be used to check the result.

With a current arrow placed on each upper lead of Fig. 1.7, directed to the right, and labeled “+2 amp,” 10 watts is absorbed by the element in *c* and *d* and -10 watts is absorbed in *a* and *b*.

The conventions for current, voltage, and power are summarized in Fig. 1-8. The sketch shows that if one terminal of the element is e volts positive with respect to the other terminal, and if a current i is entering the element through the first terminal, then a power $p = ei$ is being absorbed by or delivered to the element. This convention should be studied carefully, understood, and memorized. In other words it says that if current and voltage arrows are placed at the terminals of the element such that the voltage arrow is pointing toward the terminal into which the indicated current is flowing, and if these arrows are labeled with the appropriate algebraic quantities, the power *absorbed* by the element can then be expressed as the algebraic product of these two quantities. If

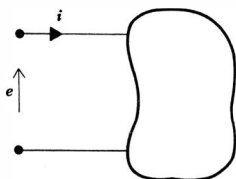

Fig. 1-8 The power absorbed by the element is given by the product, $p = ei$.

15 **Definitions and Units**

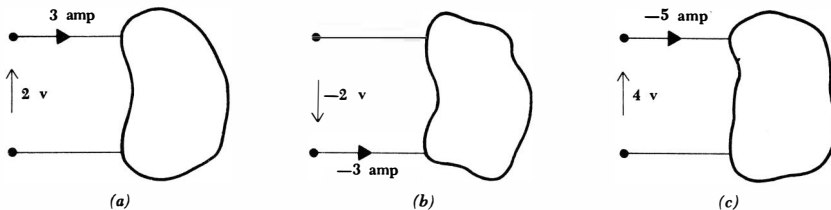

Fig. 1-9 (a) A power, $p = (2)(3) = 6$ watts, is absorbed by the element. (b) A power, $p = (-2)(-3) = 6$ watts, is absorbed by the element. (c) A power, $p = (4)(-5) = -20$ watts, is absorbed by the element, or 20 watts is delivered by the element.

the numerical value of the product is negative, then the element is absorbing negative power or delivering power to some external element. The three examples of Fig. 1-9 further illustrate this convention.

Drill Problems

1-4 Experimental measurements show that the total charge which has passed a given reference point between $t = 0$ and t is given by:

t , seconds	0	1	2	3	4
q , coulombs	0	0.414	1.000	1.828	3.000

(a) Determine the approximate current at $t = 2$ by using the charge transferred during the previous 1-sec interval. (b) Determine the approximate current at $t = 2$ by using the charge transferred during a 2-sec interval centered at $t = 2$. (c) The exact relationship between q and t is $q = 2^{t/2} - 1$. Find the exact value of i at $t = 2$.

Ans. 0.707 amp; 0.693 amp; 0.586 amp

1-5 Experimental measurements show that the current at a certain point varies with time in the following way:

t , seconds	0	1	2	3	4
i , amperes	-1.000	+0.500	+1.598	+2.000	+1.598

(a) Find the approximate average current in each 1-sec interval, the approximate charge transferred in each interval, and from this the total charge transferred between $t = 0$ and $t = 4$. (b) Find the approximate average current in each 2-sec interval, using only the data taken at $t = 0, 2,$ and 4 ; the approximate charge transferred in each of the two 2-sec intervals; and from this the total charge transferred between $t = 0$ and $t = 4$. (c) Determine the exact value of this charge if the current is $i = -1 + 3 \sin(\pi t/6)$.

Ans. 4.59 coulombs; 4.40 coulombs; 3.79 coulombs

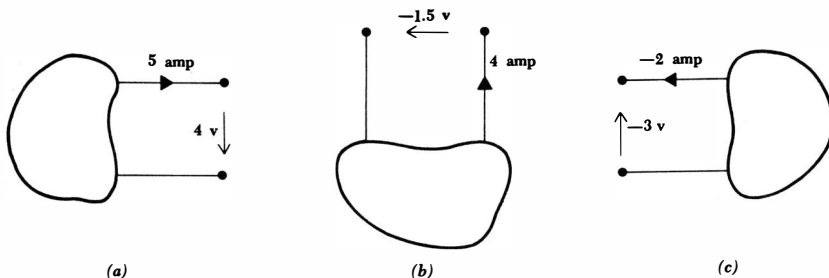

Fig. 1-10 See Drill Prob. 1-6.

1-6 Determine the power being absorbed by the elements shown in Fig. 1-10a, b, and c.

Ans. -6 watts; -6 watts; 20 watts

1-6 TYPES OF CIRCUITS AND CIRCUIT ELEMENTS

Using the concepts of current and voltage, it is now possible to be more specific in defining a circuit element.

It is important to differentiate between the physical device itself and the mathematical model of this device which we shall use to analyze its behavior in a circuit. Let us agree that we will use the expression "circuit element" to refer to the mathematical model. The choice of a particular model for any real device must be made on the basis of experimental data or experience; we shall usually assume that this choice has already been made. We must first learn the methods of analysis of idealized circuits.

Now let us distinguish a *general circuit element* from a *simple circuit element* by the statement that a general circuit element may be composed of more than one simple circuit element, but that a simple circuit element cannot be further subdivided into other simple circuit elements. For brevity, we shall agree that the term circuit element generally refers to a simple circuit element.

All the simple circuit elements that will be considered in the work that follows can be classified according to the relationship of the current through the element to the voltage across the element. For instance, if the voltage across the element is directly proportional to the current through it, or $e = ki$, we shall call the element a resistor. Other types of simple circuit elements have a terminal voltage which is proportional to the time derivative or the integral with respect to time of the current. There are also elements in which the voltage is completely independent of the current or the current is completely independent of the voltage.

By definition, a simple circuit element is the mathematical model of a two-terminal electrical device, and it can be completely characterized by its voltage-current relationship but cannot be subdivided into other two-terminal devices.

The first element which we shall need is an *ideal voltage source*. It is characterized by a terminal voltage which is completely independent of the current through it. Thus, if we are given an ideal voltage source and are notified that the terminal voltage is $50t^2$ volts, we can be sure that at $t = 1$ sec the voltage will be 50 volts, regardless of the current that was flowing, is flowing, or is going to flow. The representation of an ideal voltage source is shown in Fig. 1-11. The subscript s merely identifies the voltage as a "source" voltage.

If a current arrow is placed on the upper conductor of this source and directed to the left, then the current i is entering the terminal at which the voltage arrow-head is located and the source thus absorbs a power $p = e_s i$. More often than not, a source is expected to deliver power to a network and not to absorb it. Consequently, we might choose to direct the arrow to the right in order that $e_s i$ will represent the power delivered by the source. Either direction may be used.

The ideal voltage source does not represent exactly any real physical device, because it could theoretically deliver an infinite amount of energy from its terminals. Each coulomb passing through it receives an energy of e_s joules, and the number of coulombs per second is unlimited. The ideal voltage source does, however, furnish a reasonable approximation to several practical voltage sources. An automobile storage battery, for example, has a terminal voltage of, say, 12 volts that remains essentially constant as long as the current through it does not exceed a few amperes. The small current may be flowing in either direction through the battery, corresponding to power furnished by the battery to the headlights while it is discharging or to power absorbed by the battery from the generator or a battery charger while it is charging. An ordinary household electrical outlet also approximates an ideal voltage source providing the voltage $e_s = 115 \sqrt{2} \cos 2\pi 60t$ volts; the representation is valid for currents less than perhaps 20 amp.

An ideal voltage source which has a constant terminal voltage is often termed an ideal d-c voltage source and is represented by either symbol shown in Fig. 1-12. Note in Fig. 1-12*b* that when the physical plate structure of the battery is suggested, the longer plate is placed at the positive terminal.

The other ideal source which we will need is the *ideal current source*. Here, the current through the element is completely independent of the voltage across it. The symbol for an ideal current source is shown in Fig. 1-13. If i_s is a constant, we call the source an ideal d-c source. There is no other graphical representation for the ideal d-c source.

Like the ideal voltage source, the ideal current source is at best a reasonable approximation for a physical element. An ideal d-c source represents very closely the electron beam of a synchrotron which is operating at a constant

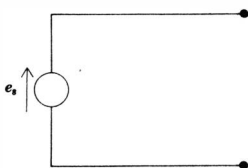

Fig. 1-11 The circuit symbol of an ideal voltage source.

The Resistive Circuit

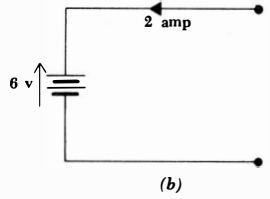
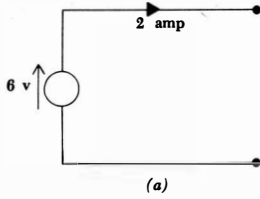

Fig. 1-12 Alternative representations of a constant or d-c ideal voltage source. In (a) the source is delivering 12 watts and in (b) the battery is absorbing 12 watts.

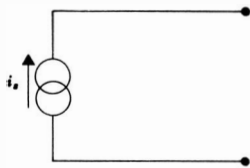

Fig. 1-13 The circuit symbol of an ideal current source.

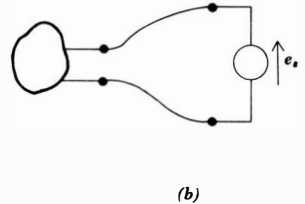
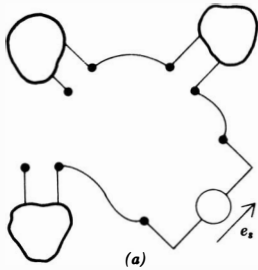
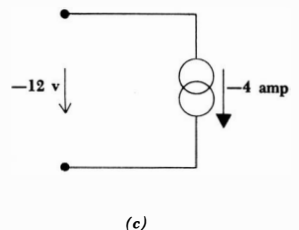
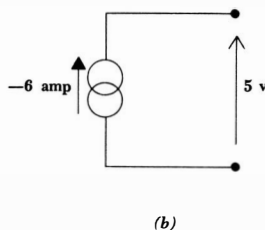
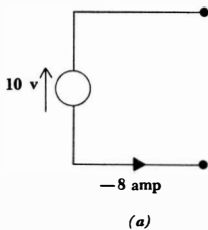

Fig. 1-14 (a) An electrical network which is not a circuit. (b) A network which is a circuit.

Fig. 1-15 See Drill Prob. 1-7.



beam current of perhaps one microampere and will continue to deliver one microampere to almost any device placed across its “terminals” (the beam and the earth). The ideal current source is also a good representation for a pentode vacuum tube, and it is very useful in simplifying the analysis of transistor and vacuum-tube operation.

Both of these sources are *active* elements; they are capable of delivering power to some external device. For the present we shall think of a *passive* element as one which is capable only of receiving power. However, we shall later see that several passive elements are able to store a finite amount of energy and then return it later to an external element, and since we shall still wish to call such an element passive, it will be necessary to improve upon our two definitions then.

The interconnection of two or more simple circuit elements is called an electrical *network*. If the network contains at least one closed path, we shall call it an electric *circuit*. Every circuit is a network, but not all networks are circuits. Figure 1-14*a* shows a network which is not a circuit, and Fig. 1-14*b* shows a network which is a circuit.

A network which contains at least one active element, such as a voltage or current source, is an *active network*. A network which does not contain any active sources is a *passive network*.

Drill Problem

1-7 Determine the power being supplied by the ideal sources shown in Fig. 1-15*a*, *b*, and *c*.

Ans. 80 watts; 48 watts; -30 watts

Problems

- ◆1 Determine the dimensional symbols for torque, angular velocity, angular acceleration, and momentum.
- 2 The total charge passing a given reference point in a specified direction is measured, and the result is plotted as a function of time in Fig. 1-16. (a) Determine the charge transferred between $t = 2$ and $t = 3$. (b) Using graphical methods, sketch the current as a function of time.
- ◆3 If $q(t) = -t^3 + 7t^2 - 11t$, find and plot $i(t)$ for $0 \leq t \leq 5$. The result should agree with the sketch of Prob. 2b.
- 4 The current flowing in a specified direction at a given point is measured, and the result is shown as a function of time in Fig. 1-17. By graphical methods determine: (a) the maximum value of the current; (b) the average value of the current in the interval $0 \leq t \leq 10$; (c) the total charge transferred past the reference point between $t = 0$ and $t = 10$.
- ◆5 If $i = \epsilon^{-0.25t} - \epsilon^{-0.5t}$, find the total charge transferred between $t = 0$ and $t = 10$. The result should check the answer of Prob. 4c.
- ◆6 (a) The current at a given point in a certain circuit may be written as a function of time, $i(t) = -3 + t$. Find the total charge passing the point between $t = 99$ and $t = 102$ sec. (b) The total charge which has moved

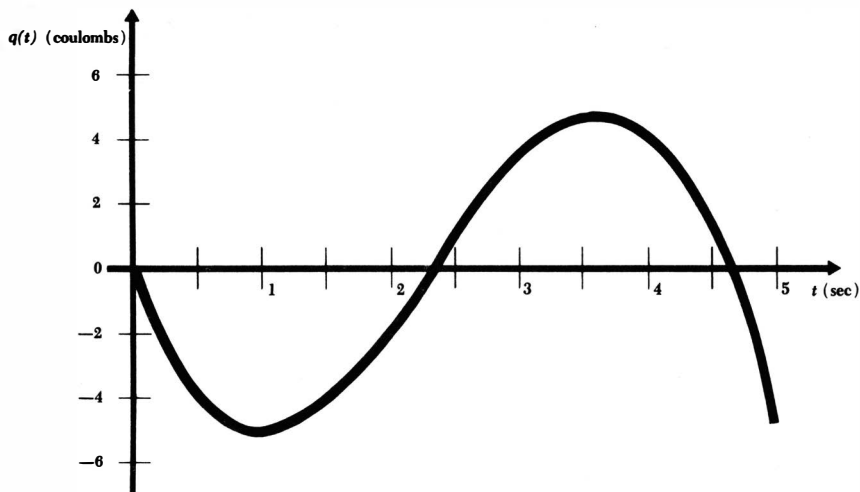
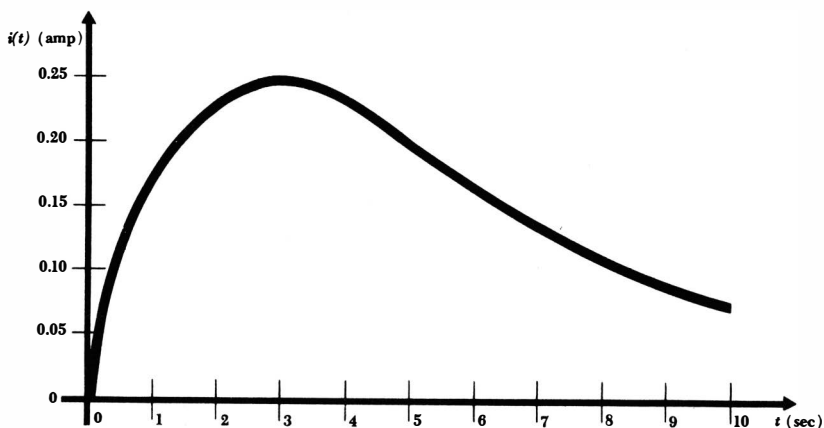

Fig. 1-16 See Prob. 2.

to the right past point A in a circuit since $t = 0$ is expressed as a function of time, $q(t) = -3 + t$. Find the current flowing to the left at point A at $t = 3$ sec.

- 7 In charging a storage battery it is found that an energy of 1 watt-hr is expended in 15 minutes in sending 150 coulombs through the battery. (a) What is the voltage between the battery terminals? (b) What is the magnitude of the average charging current?
- 8 Protons enter a certain particle accelerator with no kinetic energy and

Fig. 1-17 See Prob. 4.



21 Definitions and Units

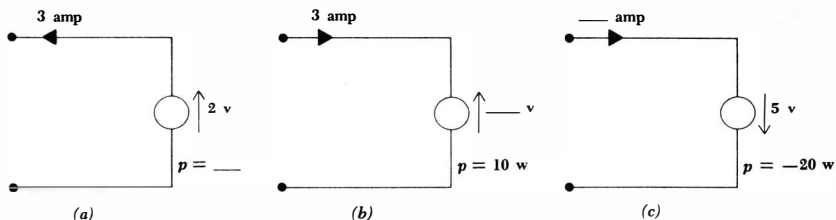

Fig. 1-18 See Prob. 11.

leave with an energy of 10^{-12} joule. If 10^{14} protons pass through each second: (a) what is i_s for this “d-c source,” and (b) what is the “voltage” between its “terminals”?

- ◆9 A periodic voltage for which $e = 10$ volts, $0 < t < 2$; $e = 0$ volts, $2 < t < 5$; $e = 10$ volts, $5 < t < 7$; $e = 0$ volts, $7 < t < 10$; etc.; is applied to a general circuit element. Terminal A is positive with respect to terminal B by this voltage. The current entering the element at terminal B is also periodic: $i = 0$ amp, $0 < t < 1$; $i = 2$ amp, $1 < t < 3$; $i = 0$ amp, $3 < t < 6$; $i = 2$ amp, $6 < t < 8$; $i = 0$ amp, $8 < t < 11$; etc. Find the average power delivered to or absorbed by the element, and state whether the element is active or passive.
- 10 Terminal A of a simple circuit element is 1 volt positive with respect to terminal B , and a current of 1 amp is entering the element at terminal A . Sketch the element and indicate the values of current and voltage. Now indicate seven other equivalent methods of indicating this same voltage and current on the element.
- 11 Complete the sketches shown in Fig. 1-18 so that the current, voltage, and absorbed power are clearly indicated on each.
- ◆12 A certain passive circuit element has the characteristic that the instantaneous voltage across it is always exactly three times the cube of the instantaneous current through it. (a) What power is being dissipated when $i = 0.1, 1, 10$ amp? (b) If $i = 2 \sin 2\pi t$, sketch $e(t)$, $-1 \leq t \leq 1$.

Chapter 2 *Experimental Laws and Simple Circuits*

2-1 INTRODUCTION

In the last chapter we became familiar with the ideal voltage and current sources and were cautioned that they were idealized elements which could only be approximated in a real circuit. Another idealized element, the linear resistor, will be introduced in this chapter.

We must next accept two fundamental laws as being axiomatic. With these laws, with the three simple circuit elements, and with the few definitions we already have, we may then begin to study simple electric circuits. This study will be restricted almost completely to *analysis*, which is the process by which the voltage and current associated with each element in a given circuit are determined. Fortunately, a complete analysis is not usually necessary, for often only a specific current, voltage, or perhaps power is needed.

After a proficiency in analysis has been achieved in this and other early courses, problems in *synthesis* may be considered. Here we are given a mathematical description of the desired behavior of a circuit and must determine the necessary elements and their interconnection in order to obtain the desired response. Synthesis problems may often have more than one solution.

The final type of circuit problem, and the one for which engineering salaries are most often paid, is that of *design*. A real, physical, manufacturable, salable, economical, reliable device is the desired end product. Sometimes size, weight, temperature characteristics, and even eye appeal must be considered in the design. It is obvious that experience is a prerequisite for design proficiency; it is also evident that analysis and synthesis must come first.

This chapter and the following one are restricted to the analysis of simple circuits containing only ideal current sources, ideal voltage sources, and resistors. In analyzing these circuits we shall use several network transformations, network theorems, and mathematical methods which we shall later be able to apply, with only slight modifications, to circuits containing other types of

passive elements excited by time-varying sources. We shall learn the methods useful in circuit analysis by applying them to the simplest possible case, the resistive circuit.

2-2 OHM'S LAW

The simplest passive element, the resistor, may be introduced by considering the work of an obscure German physicist, George Simon Ohm, who published a pamphlet in 1827 entitled "Die galvanische Kette mathematisch bearbeitet."¹ In it were contained the results of one of the first efforts to measure currents and voltages and to describe and relate them mathematically. One result was a statement of the fundamental relationship we now call Ohm's law, even though it has since been shown that this result was discovered 46 years earlier in England by Henry Cavendish, a brilliant semirecluse. However, no one, including Ohm, we shall hope, knew of the work done by Cavendish because it was not uncovered and published until long after both were dead. .

Ohm's pamphlet received much undeserved criticism and ridicule for several years after its first publication, but it was later accepted and served to remove the obscurity associated with his name.

Ohm's law states that the voltage across many types of conducting materials is directly proportional to the current flowing through the material,

$$e = iR$$

where the constant of proportionality R is called the *resistance*. The unit of resistance is the *ohm* [$ML^2T^{-1}Q^{-2}$], which is one volt per ampere and customarily abbreviated by a capital omega, Ω .

When this equation is plotted on e versus i axes, it is a straight line passing through the origin. The equation is a linear equation, and we shall consider it as the definition of a *linear resistor*. Hence, if the ratio of the current and voltage associated with any simple circuit element is a constant, then the element is a linear resistor and has a resistance equal to the voltage-current ratio.

Again, it must be emphasized that the linear resistor is an idealized circuit element; it is a mathematical model of a physical device. "Resistors" may be easily purchased or manufactured, but it is soon found that the voltage-current ratio of this physical device is reasonably constant only within certain ranges of current, voltage, or power and depends also on temperature and other environmental factors. We shall usually refer to a linear resistor as simply a resistor, using the longer term only when the linear nature of the element needs emphasis. Any resistor which is nonlinear will always be described as such. Nonlinear resistors should not necessarily be considered as undesirable elements. Although it is true that their presence complicates an analysis, the performance of the device may depend on or be greatly improved by the nonlinearity. Zener diodes, voltage-regulator tubes, and fuses are such elements.

Figure 2-1 shows the most common circuit symbol used for a resistor. In

¹"The Galvanic Circuit Investigated Mathematically."

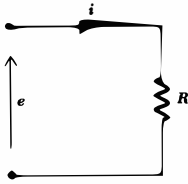

Fig. 2-1 The circuit symbol for a resistor. $R = e/i$ and $p = ei = i^2R = e^2/R$.

accordance with the voltage, current, and power conventions adopted in the last chapter, the product of e and i gives the power absorbed by the resistor. This absorbed power appears physically as heat and is always positive; a resistor is a passive element that cannot deliver power or store energy. Alternative expressions for the absorbed power are

$$p = ei = i^2R = \frac{e^2}{R}$$

The ratio of current to voltage is also a constant,

$$\frac{i}{e} = G$$

where G is called the *conductance*. The unit of conductance is the *mho* [$M^{-1}L^{-2}TQ^2$], one ampere per volt, and is abbreviated by an inverted omega, \mathfrak{O} . The same circuit symbol is used to represent both resistance and conductance. The absorbed power is again necessarily positive and may be expressed in terms of the conductance by

$$p = ei = e^2G = \frac{i^2}{G}$$

Thus a 2-ohm resistor has a conductance of $\frac{1}{2}$ mho, and if a current of 5 amp is flowing through it, a voltage of 10 volts is present across the terminals and a power of 50 watts is being absorbed.

All the expressions above have been written in terms of instantaneous current, voltage, and power, such as $e = iR$ and $p = ei$. It is apparent that the current through and voltage across a resistor must both vary with time in the same manner. Thus, if $R = 10$ ohms and $e = 2 \sin 100t$, then $i = 0.2 \sin 100t$; the power, however, is $0.4 \sin^2 100t$, and a simple sketch will illustrate the different nature of its variation with time. Although the current and voltage are each negative during certain time intervals, the absorbed power is never negative.

Drill Problems

2-1 Find the resistance of a resistor that: (a) has a voltage of 100 volts across it and a current of 20 amp through it; (b) absorbs 48 watts with a current of 4 amp flowing through it; (c) has a voltage of 50 volts across it and is absorbing energy at the rate of 1000 joules/sec.

Ans. 3 ohms; 2.5 ohms; 5 ohms

2-2 Find the power absorbed by a resistor that: (a) has a conductance of 2 mmhos and draws 100 ma; (b) dissipates 10 watts when a current of 500 amp flows through it; (c) has a conductance of 25 μ mhos and requires 400 joules to force 2 coulombs through it.

Ans. 5 watts; 1 watt; 10 watts

2-3 KIRCHHOFF'S LAWS

We are now ready to consider current and voltage relations in simple networks resulting from the interconnection of two or more simple elements. The elements will be connected by electrical conductors, or leads, which have zero resistance, or are *perfectly conducting*. Since the network then appears as a number of simple elements and a set of connecting leads, it is called a *lumped-constant network*. A more difficult analysis problem arises when we are faced with a *distributed-constant network*, which essentially contains an infinite number of vanishingly small elements. This latter type of network is considered in later courses.

A point at which two or more elements have a common connection is called a *node*. Figure 2-2a shows a circuit containing three nodes. Sometimes networks are drawn so as to trap an unwary student into believing that there are more nodes present than is actually the case. This occurs when a node, such as node 1 in Fig. 2-2a, is shown as two separate junctions connected by a (zero-resistance) conductor. However, all that has been done is to spread the common point out into a common line. Node 1 has been redrawn in this fashion in Fig. 2-2b.

Another term whose use will prove convenient is a branch. We may define a *branch* as a single path containing one simple element which connects one node to any other node. The circuit shown in Fig. 2-2a and b contains five branches.

We are now ready to consider the first of the two laws named for Gustav Robert Kirchhoff, a German university professor who was born about the time Ohm was doing his experimental work. This axiomatic law is called Kirchhoff's current law, and it states that the algebraic sum of all the currents entering any node is zero.

Although we cannot rigorously prove the law at this time,² we should at least

² The proof is based on the hypothesis that charge is conserved, or that it can be neither created nor destroyed. We might just as well accept Kirchhoff's current law as being axiomatic instead of accepting the conservation of charge.

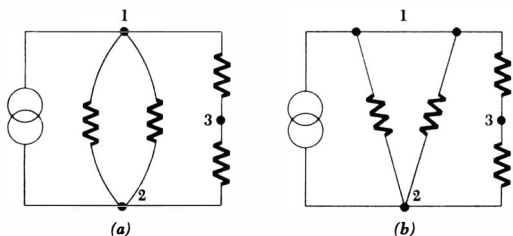

Fig. 2-2 (a) A circuit containing three nodes. (b) Node 1 is redrawn to look like two nodes; it is still one node.

agree that it seems plausible. Suppose we consider the node shown in Fig. 2-3 at which three elements are joined together. Surrounding this node is a closed surface containing a volume V , within which we shall let the total charge be q . The total current entering V is therefore the algebraic sum of all the currents entering V , $i_A + i_B + i_C$. This is equivalent to stating that charge is entering V at the rate of $i_A + i_B + i_C$ coulombs/sec. Hence, the charge q within V must be increasing at the rate of $i_A + i_B + i_C$ coulombs/sec, and

$$i_A + i_B + i_C = \frac{dq}{dt}$$

Now we let V become vanishingly small and find that no electrical device other than the node itself is within V . A node, however, cannot store, destroy, or generate charge. Therefore, dq/dt must be zero, and

$$i_A + i_B + i_C = 0$$

This argument may be extended to any number of branches joined at a node.

It is evident that we may also state Kirchhoff's current law in other ways. For instance, the algebraic sum of all the currents *leaving* a node is zero, or the algebraic sum of all the currents entering a node must equal the algebraic sum of all the currents leaving a node. These three forms lead directly to the three equivalent equations written below for the node shown in Fig. 2-4,

$$\begin{aligned} i_A + i_B - i_C - i_D &= 0 \\ i_C + i_D - i_A - i_B &= 0 \\ i_A + i_B &= i_C + i_D \end{aligned}$$

A compact expression for Kirchhoff's current law is

$$\sum_{n=1}^N i_n = 0$$

and this is just a shorthand statement for

$$i_1 + i_2 + i_3 + \cdots + i_N = 0$$

When this form is used, it is understood that the N current arrows either are all directed toward the node in question or are all directed away from it.

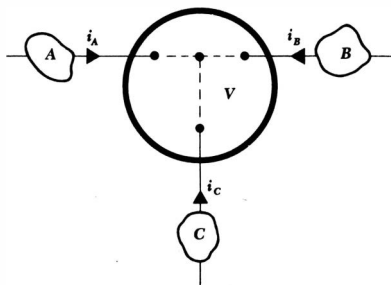

Fig. 2-3 A closed surface surrounds a volume V and encloses a node.

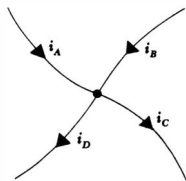

Fig. 2-4 Kirchhoff's current law enables us to write $i_A + i_B - i_C - i_D = 0$, $i_C + i_D - i_A - i_B = 0$, or $i_A + i_B = i_C + i_D$.

It is sometimes helpful to interpret Kirchhoff's current law in terms of a hydraulic analogy. Water, like charge, cannot be stored at a point, and thus if we identify a junction of several pipes as a node, it is evident that the number of gallons of water entering the node every second must equal the number of gallons leaving the node each second.

We now turn to Kirchhoff's *voltage law*. This law states that the algebraic sum of the voltages around any closed path in a circuit is zero. Again, we must accept this law as an axiom, even though it is developed in introductory electromagnetic theory.

In view of our definition of voltage as the energy expended in moving a unit positive charge through the element, an equivalent statement of Kirchhoff's voltage law would seem to say that no energy is expended in moving the unit positive charge about any closed path. It turns out that this statement is correct for a circuit, or at least for its mathematical model; it is *not* true for a general path in a region of space containing time-varying magnetic fields. This statement may be clarified by considering a gravitational analogy. To raise a mass from a point at one elevation to a higher point and then to lower it to the original point requires no net expenditure of energy, regardless of the path taken. This interpretation corresponds to the application of Kirchhoff's voltage law to a circuit. However, let us suppose that there is a strong narrow jet of wind blowing upward at one point on the earth's surface. If we lift our mass outside the jet and then lower it within the jet, we must obviously do more work than if we had reversed the procedure, that is, raising it within the jet and lowering it outside it. The work we do depends on the path. The presence of a time-varying magnetic field has much the same effect; the energy we expend in moving the charge depends on the particular path we take through the magnetic field. Now, time-varying magnetic fields are intimately associated with inductors, as we shall see in Chap. 4, but Kirchhoff's voltage law may still be applied to circuits containing inductors. The reason is that, as soon as an inductance value is specified, a path is inferred. In circuit analysis, we are not concerned with the specific path taken through the inductor; we are concerned only with the voltage-current relationships at the element *terminals* and with the energy required to move a unit positive charge through the element.

In summary, then, Kirchhoff's voltage law is applicable to circuits because physical devices are reduced to mathematical models in such a way that the law will be applicable. We should not be surprised to find that the work expended in carrying a unit positive charge around some closed path in space is not always zero.

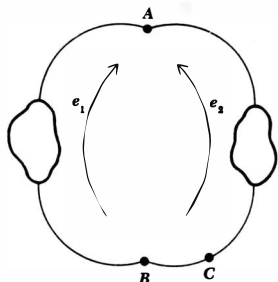

Fig. 2-5 A simple circuit consisting of two elements connected together.

In a *circuit*, then, there is a single, definite value of energy associated with the two terminals of the element. Let us see how this statement leads to Kirchhoff's voltage law. Everybody who performs the coulomb-carrying experiment arrives at the same answer, regardless of the path taken in moving the charge about the circuit. Suppose that we have a choice of two paths along which we may move our charge from one point to another in a circuit, such as that available when two elements are connected as shown in Fig. 2-5. We may proceed from *A* to *B* either through the element on the left or through that on the right. We should expect the energy expended to be the same along either path. Thus the voltages e_1 and e_2 are equal,

$$e_1 = e_2 \quad \text{or} \quad e_2 - e_1 = 0$$

Since $e_2 - e_1$ is the algebraic sum of the voltages around this closed path, then Kirchhoff's voltage law is satisfied.

Let us consider this same circuit in a slightly different way by determining the voltage between points *B* and *C*. We first carry our coulomb from *B* to *A* through the left element, supplying e_1 joules of electrical energy to our coulomb, and then proceed to *C* through the right element, losing e_2 joules of electrical energy from our coulomb. The voltage between *B* and *C* along this path is thus

$$e_{BC} = -e_1 + e_2 = e_2 - e_1$$

However, we might also choose the short path along the perfect conductor connecting *B* directly to *C*. The voltage here must be zero, for any nonzero voltage across a zero resistance will give rise to an infinite current which we reject as a physical impossibility. The voltage by this direct path is thus

$$e_{BC} = 0$$

If we again assume that the voltage or energy obtained along different paths is the same, then, once more,

$$e_2 - e_1 = 0$$

This latter point of view enables us to consider circuits composed of any number of elements connected in a single loop. Since the voltage across a short piece of one of the perfect conductors must be zero, then the voltage around the remainder of the circuit must be zero. Thus, we may write

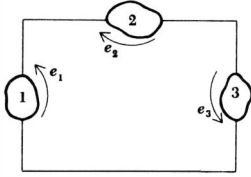

Fig. 2-6 A circuit used to illustrate different methods of applying Kirchhoff's voltage law.

$$\sum_{n=1}^N e_n = 0 \quad \text{or} \quad e_1 + e_2 + e_3 + \dots + e_N = 0$$

where we agree that all the voltage arrows are directed the same way about the path (all clockwise or all counterclockwise).

We may apply Kirchhoff's voltage law in several different ways. For instance, in the circuit of Fig. 2-6, the voltage arrows unfortunately do not all point in one direction. We might choose to reverse the arrow across element 2 and then let that voltage be $-e_2$. It follows then that,

$$e_1 + (-e_2) + e_3 = 0$$

We could instead reverse the arrows on the other two elements and change the signs on their voltages,

$$(-e_1) + e_2 + (-e_3) = 0$$

Usually, it is much easier to move around the circuit mentally, writing down directly each voltage whose arrow is pointing in a direction opposed to that in which we are traveling and writing down the negative of every voltage which is directed with us. Clockwise travel around the above circuit then gives

$$-e_1 + e_2 - e_3 = 0$$

whereas counterclockwise travel yields

$$e_1 - e_2 + e_3 = 0$$

These last four results are identical.

Drill Problems

2-3 How many nodes are present in the circuit of Fig. 2-7a, b, and c?

Ans. 4; 5; 5

Fig. 2-7 See Drill Prob. 2-3.

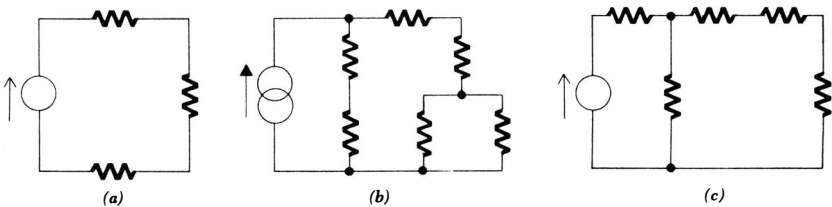

30 **The Resistive Circuit**

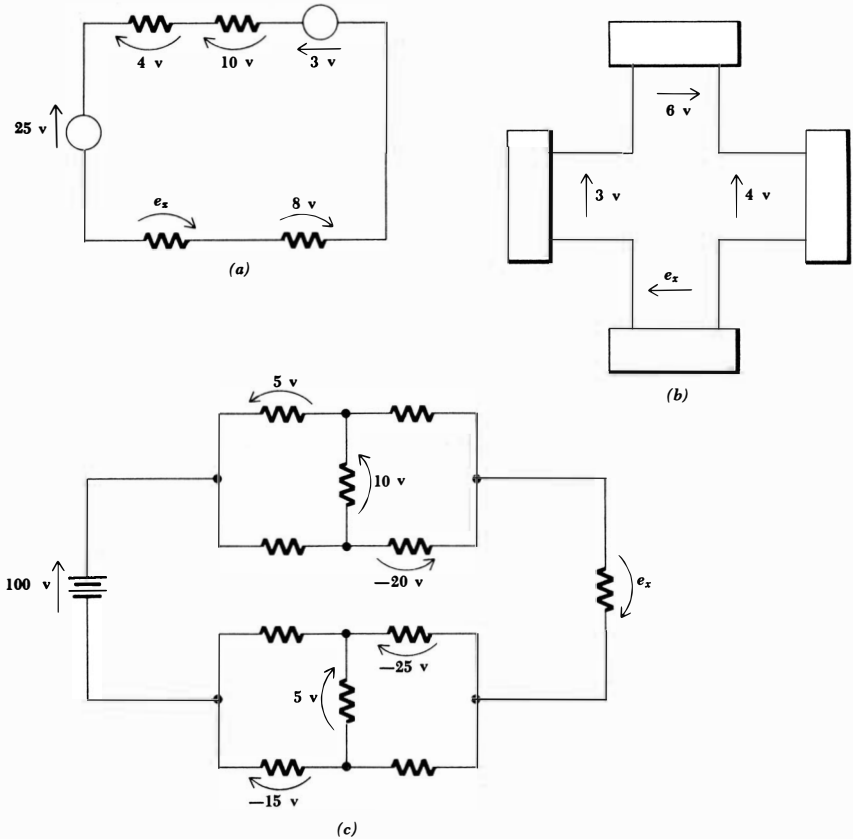

Fig. 2-8 See Drill Prob. 2-4.

2-4 Determine e_x in the circuit of Fig. 2-8a, b, and c.

Ans. -20 volts; -5 volts; 0 volts

2-5 Determine i_x in the circuits of Fig. 2-9a, b, and c.

Ans. 15 amp; 9 amp; 8 amp

2-4 ANALYSIS OF A SINGLE-LOOP CIRCUIT

Having established Ohm's and Kirchhoff's laws, we may flex our analytical muscles by applying these tools in the analysis of a simple resistive circuit, such as the one shown in Fig. 2-10a. We shall assume that the resistance values and the source voltages are known and attempt to determine the current through

each element, the voltage across each element, and the power delivered to or absorbed by each element.

Our first step in the analysis is the assumption of directions for the unknown currents since we do not know a priori what these directions are. Arbitrarily, let us select an unknown current i which flows out of the upper terminal of the left voltage source. This choice is indicated by an arrow at that point in the circuit, as shown in Fig. 2-10b. A trivial application of Kirchoff's current law assures us that this same current must also flow through every other element in the circuit. We may emphasize this fact this one time by placing several other current symbols about the circuit.

By definition, all the elements that carry the *same* current are said to be connected in *series*. Note that elements may carry *equal* currents and not be in series; two 100-watt lamp bulbs in neighboring houses may very well carry equal currents, but they do not carry the same current and are not in series.

Our second step in the analysis is the choice of a voltage sense across each of the two resistors. We have already found that the application of Ohm's law, $e = iR$, demands that the sense of the current and voltage be selected so

Fig. 2-9 See Drill Prob. 2-5.

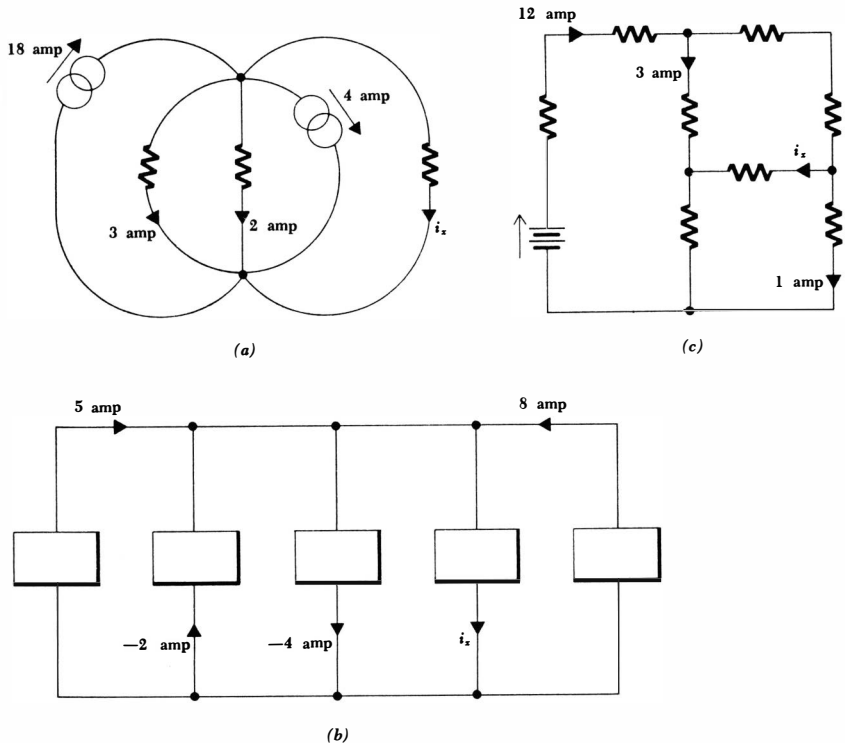

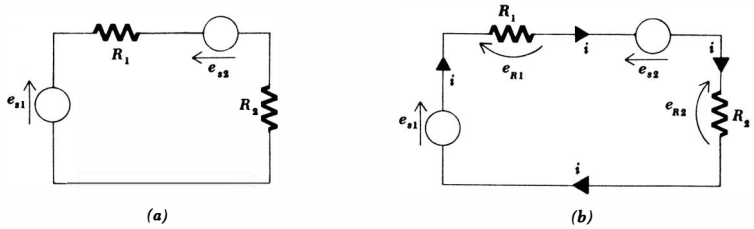

Fig. 2-10 (a) A single-loop d-c circuit in which the source voltages and resistances are given. (b) Current and voltage sense arrows have been added to the circuit.

that the current enters the terminal at which the voltage arrowhead is located. If the choice of the current direction is arbitrary, then the selection of the voltage sense is fixed if we intend to use Ohm's law in the form $e = iR$. The voltages e_{R1} and e_{R2} are shown in Fig. 2-10b.

The third step is the application of Kirchhoff's voltage law to the single closed path present. Let us decide to move around the circuit in the clockwise direction, beginning at the lower left corner, and write down directly every voltage whose arrow opposes our direction of travel and write down the negative of every voltage whose arrow agrees with our direction. Thus,

$$-e_{s1} + e_{R1} + e_{s2} + e_{R2} = 0$$

Finally, we apply Ohm's law to the resistive elements,

$$e_{R1} = iR_1 \quad \text{and} \quad e_{R2} = iR_2$$

and obtain

$$-e_{s1} + iR_1 + e_{s2} + iR_2 = 0$$

This equation is solved for i , and thus

$$i = \frac{e_{s1} - e_{s2}}{R_1 + R_2}$$

where all the quantities on the right side are known and enable us to determine i . The voltage or power associated with any element may now be obtained in one step by applying $e = iR$, $p = ai$, or $p = i^2R$.

Let us consider the numerical example illustrated in Fig. 2-11a. Two batteries and two resistors are connected in a series circuit. The batteries are said to be *series opposing* since any assumed current must flow into the positive terminal of one but out of the positive terminal of the other. If either is reversed, they will be *series aiding*. Currents and voltages are assigned to the circuit and indicated in Fig. 2-11b, and Kirchhoff's voltage law yields

$$-120 + e_{30} + 30 + e_{15} = 0$$

33 Experimental Laws and Simple Circuits

An application of Ohm's law to each resistor permits us to write

$$-120 + 30i + 30 + 15i = 0$$

from which

$$i = \frac{120 - 30}{30 + 15} = 2 \text{ amp}$$

Thus, the voltage across each resistor is

$$e_{30} = 2(30) = 60 \text{ volts} \quad e_{15} = 2(15) = 30 \text{ volts}$$

The power absorbed by each element has been shown to be given by the product of the voltage across the element and the current flowing into the element terminal at which the voltage arrowhead is located. For the 120-volt battery, then, the power absorbed is

$$p_{120v} = 120(-2) = -240 \text{ watts}$$

and thus 240 watts is *delivered* to other elements in the circuit by this source. In a similar manner,

$$p_{30v} = 30(2) = 60 \text{ watts}$$

and we find that this nominally active element is actually absorbing power, delivered to it by the other battery.

The power absorbed by each resistor is necessarily positive and may be calculated by

$$p_{30} = e_{30}i = 60(2) = 120 \text{ watts}$$

or by

$$p_{30} = i^2R = 2^2(30) = 120 \text{ watts}$$

and $p_{15} = e_{15}i = i^2R = 60 \text{ watts}$

Fig. 2-11 (a) A given series circuit. (b) The circuit with current and voltage symbols added.

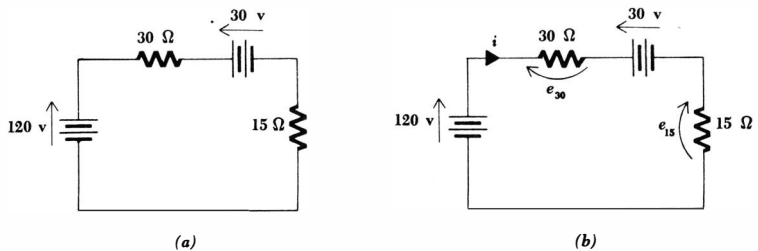

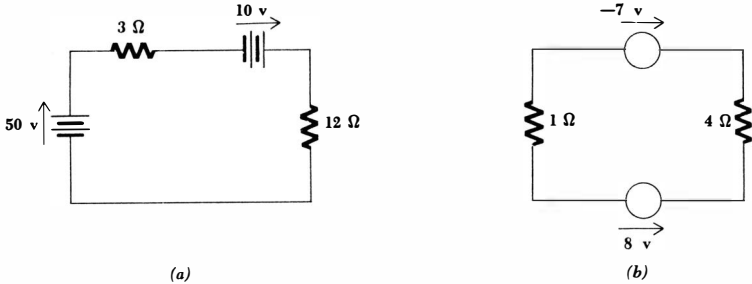

Fig. 2-12 (a) See Drill Prob. 2-6. (b) See Drill Prob. 2-7.

The results check because the total power absorbed must be zero, or in other words, the power delivered by the 120-volt battery is exactly equal to the sum of the powers absorbed by the three other elements. A power balance is often a useful method of checking for careless mistakes.

Before leaving this example, it is important that we be convinced that our initial assumption of a direction for current flow had nothing to do with the answers obtained. Let us suppose that we assumed the current i to be directed in a counterclockwise direction. Both resistor voltages must then be assigned opposite directions also, and we should have obtained

$$-120 - 30i + 30 - 15i = 0$$

and $i = -2$ amp, $e_{30} = -60$ volts, and $e_{15} = -30$ volts. Since each arrow now has the opposite direction and each quantity is the negative of the previously obtained value, it is evident that the results are the same. Each absorbed power will be the same.

Any random or convenient choice of current direction may be made. Those who insist on positive answers may always go back and reverse the direction of the current arrow and rework the problem.

Drill Problems

2-6 In the circuit of Fig. 2-12a, find: (a) the power absorbed by the 3-ohm resistor; (b) the power absorbed by the 12-ohm resistor; (c) the power delivered by the 50-volt source.

Ans. 48 watts; 200 watts; 192 watts

2-7 In the circuit of Fig. 2-12b, find: (a) the power absorbed by the -7 -volt source; (b) the power delivered by the 8-volt source; (c) the power dissipated in the 4-ohm resistor.

Ans. 24 watts; 36 watts; -21 watts

2-5 THE SINGLE NODE-PAIR CIRCUIT

The companion of the single-loop circuit discussed above is the single node-pair circuit in which any number of simple elements are connected between the same pair of nodes. An example of such a circuit is shown in Fig. 2-13a. The two current sources and the conductance values are known, and we are to find the voltage, current, and power associated with each element once more.

Our first step is now to assume a voltage across any element, utilizing any polarity or direction we desire. Then Kirchhoff's voltage law forces us to recognize that the voltage across each branch is the same because a closed path proceeds through any branch from one node to the other and then is completed through any other branch. A total voltage of zero requires an identical voltage across every element. We shall say that elements having a common voltage across them are connected in *parallel*. Let us call this voltage e and arbitrarily select it as shown in Fig. 2-13b.

Two currents, flowing in the resistors, are then selected in conformance with the convention established with Ohm's law. These currents are also shown in Fig. 2-13b.

Our third step in the analysis of the single node-pair circuit is the application of Kirchhoff's current law to either of the two nodes in the circuit. It is usually clearer to apply it to the node at which the voltage arrowhead is located, and thus we shall equate the algebraic sum of the currents leaving the upper node to zero,

$$-120 + i_{30} + 30 + i_{15} = 0$$

Finally, the current in each resistor is expressed in terms of e and the conductance of the resistor by Ohm's law,

$$i_{30} = 30e \quad \text{and} \quad i_{15} = 15e$$

and we obtain

$$-120 + 30e + 30 + 15e = 0$$

Fig. 2-13 (a) A single node-pair circuit. (b) A voltage and two currents are assigned.

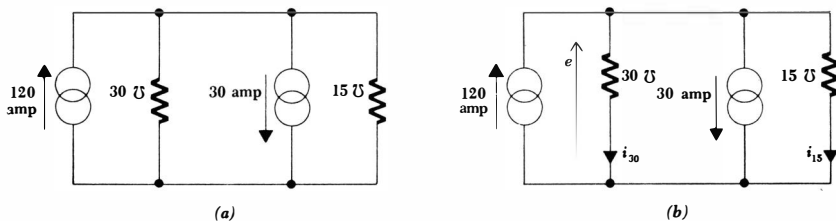

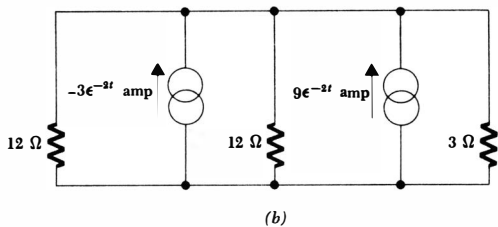
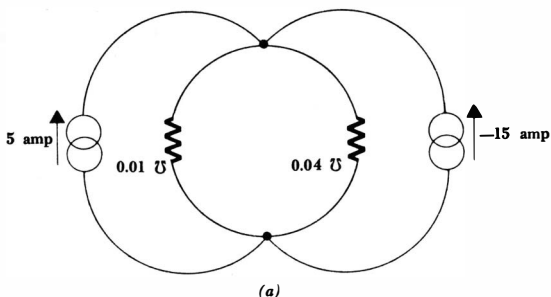

Fig. 2-14 (a) See Drill Prob. 2-8. (b) See Drill Prob. 2-9.

Thus,

$$e = 2 \text{ volts}$$

$$i_{30} = 60 \text{ amp} \quad \text{and} \quad i_{15} = 30 \text{ amp}$$

The several values of absorbed power are now easily obtained. In the two resistors,

$$p_{30} = 30(2)^2 = 120 \text{ watts} \quad p_{15} = 15(2)^2 = 60 \text{ watts}$$

and for the two sources,

$$p_{120a} = 120(-2) = -240 \text{ watts} \quad p_{30a} = 30(2) = 60 \text{ watts}$$

Thus, the larger current source delivers 240 watts to the other three elements in the circuit, and the conservation of energy is checked again.

The similarity of this example to the one previously completed, illustrating the solution of the series circuit, should not have gone unnoticed. The numbers are all the same, but currents and voltages, resistances and conductances, and “series” and “parallel” are interchanged. This is an example of *duality*, and the two circuits are said to be *exact duals* of each other. If the element values or source values were changed in either circuit, without changing the configuration of the network, the two circuits would be *duals*, although not *exact duals*. We shall study and use duality later, and at this time should only suspect that any result we obtain in terms of current, voltage, and resistance in a series circuit will have its counterpart in terms of voltage, current, and conductance for a parallel circuit.

Drill Problems

2-8 In the circuit of Fig. 2-14*a*, find: (a) the power absorbed by the 0.01-mho conductance; (b) the power absorbed by the 0.04-mho conductance; (c) the power delivered by the 5-amp source.

Ans. -1000 watts; 1600 watts; 400 watts

2-9 In the circuit of Fig. 2-14*b*, find: (a) the power absorbed by the 3-ohm resistor; (b) the power absorbed by the 9-amp source; (c) the power absorbed by the -3-amp source.

Ans. $48e^{-4t}$ watts; $36e^{-4t}$ watts; $-108e^{-4t}$ watts

2-6 RESISTANCE AND SOURCE COMBINATION

Some of the equation writing that we have been doing for the simple series and parallel circuits can be avoided. This is achieved by replacing relatively complicated resistor combinations by a single equivalent resistor whenever we are not specifically interested in the current, voltage, or power associated with any of the individual resistors in the combinations. All the current, voltage, and power relationships in the remainder of the circuit will be the same.

We first consider the series combination of N resistors, shown schematically in Fig. 2-15*a*. The broken line surrounding the resistors is intended to suggest that they are enclosed in a "black box," or perhaps in another room, and we wish to replace the N resistors by a single resistor R_{eq} so that the remainder of the circuit, in this case only the voltage source, does not realize that any change has been made. The source current, power, and, of course, the voltage will be the same before and after.

We apply Kirchhoff's voltage law

$$e_s = e_1 + e_2 + \dots + e_N$$

Fig. 2-15 (a) A circuit containing a series combination of N resistors. (b) A simpler equivalent circuit.

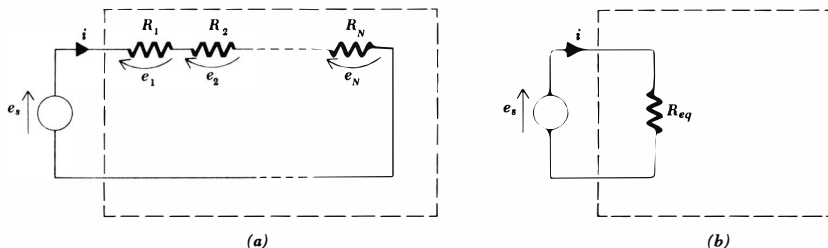

and Ohm's law

$$e_s = iR_1 + iR_2 + \cdots + iR_N = i(R_1 + R_2 + \cdots + R_N)$$

and then compare this result with the simple equation applying to the equivalent circuit shown in Fig. 2-15*b*,

$$e_s = iR_{eq}$$

Thus, the value of the equivalent resistance for N series resistances is

$$R_{eq} = R_1 + R_2 + \cdots + R_N$$

It should be emphasized again that if we are particularly interested in the power delivered to R_3 , for instance, and if R_3 is then combined with several other series resistors to form an equivalent resistance, then R_3 is gone and the power delivered to it cannot be determined until R_3 is identified by removing it from the combination.

An inspection of the Kirchhoff voltage equation for a series circuit also shows two other possible simplifications. Several ideal voltage sources in series may be replaced by an equivalent ideal voltage source having a voltage equal to the algebraic sum of the individual sources, and the order in which elements are placed in the series circuit makes no difference.

These simplifications may be illustrated by considering the circuit shown in Fig. 2-16*a*. We first interchange the element positions in the circuit, being careful to preserve the proper sense of the sources, and then combine the three voltage sources into an equivalent 90-volt source and the four resistors into an equivalent 30-ohm resistance, as shown in Fig. 2-16*b*. Thus, instead of writing

$$-80 + 10i - 30 + 7i + 5i + 20 + 8i = 0$$

we have simply

$$-90 + 30i = 0$$

and

$$i = 3 \text{ amp}$$

In order to calculate the power delivered to the circuit by the 80-volt source appearing in the given circuit, it is necessary to return to that circuit with the knowledge that the current is 3 amp. The desired power is 240 watts.

Fig. 2-16 (a) A given series circuit. (b) A simpler equivalent circuit.

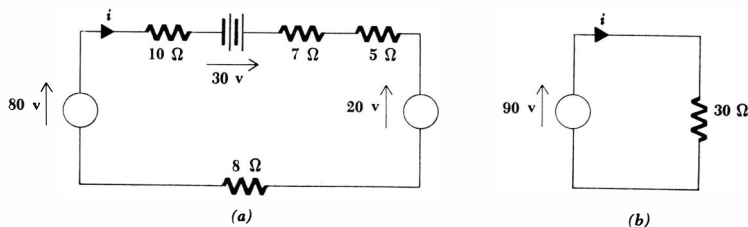

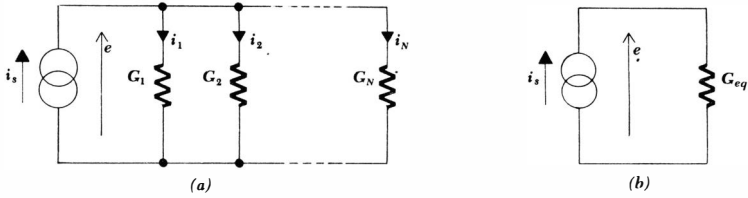

Fig. 2-17 (a) A circuit containing N parallel resistors having conductances G_1, G_2, \dots, G_N . (b) A simpler equivalent circuit.

It is interesting to note that no element of the original circuit remains in the equivalent circuit, unless we are willing to count the interconnecting wires as elements.

Similar simplifications can be applied to parallel circuits.³ A circuit containing N conductances in parallel, as in Fig. 2-17a, leads to the Kirchhoff current law equation,

$$i_s = i_1 + i_2 + \dots + i_N$$

or
$$i_s = eG_1 + eG_2 + \dots + eG_N = e(G_1 + G_2 + \dots + G_N)$$

whereas its equivalent in Fig. 2-17b gives

$$i_s = eG_{eq}$$

and thus

$$G_{eq} = G_1 + G_2 + \dots + G_N$$

In terms of resistance instead of conductance,

$$\frac{1}{R_{eq}} = \frac{1}{R_1} + \frac{1}{R_2} + \dots + \frac{1}{R_N}$$

or
$$R_{eq} = \frac{1}{1/R_1 + 1/R_2 + \dots + 1/R_N}$$

This last equation is probably the most often used means of combining parallel resistive elements.

The special case of only two parallel resistors

$$R_{eq} = \frac{1}{1/R_1 + 1/R_2} \quad \text{or} \quad R_{eq} = \frac{R_1 R_2}{R_1 + R_2}$$

is needed very often. The last form is worth memorizing.

Parallel current sources may also be combined by algebraically adding the individual currents, and the order of the parallel elements may be rearranged as desired.

³ Duality.

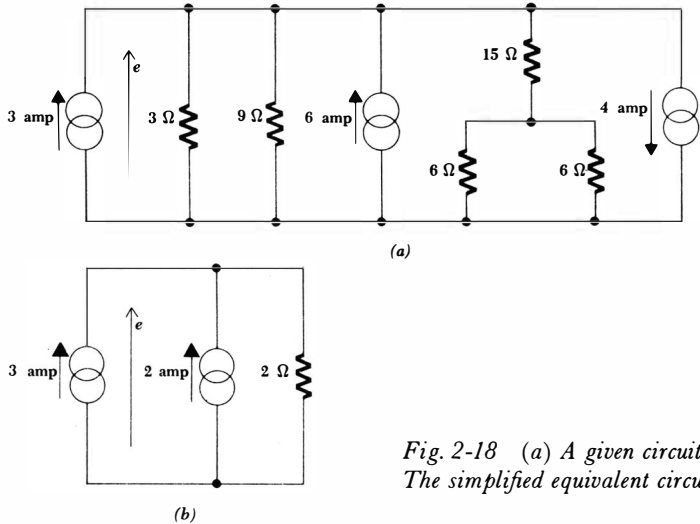

Fig. 2-18 (a) A given circuit. (b) The simplified equivalent circuit.

The various combinations described in this section are used to simplify the circuit of Fig. 2-18a. Let us suppose that we wish to know the power and voltage of the 3-amp source. We may just as well leave it alone, then, and combine the remaining two sources into one 2-amp source. The resistances are combined by beginning perhaps with the 3- and 9-ohm elements. Their parallel equivalent is 2.25 ohms. The next step *must* be the parallel combination of the two 6-ohm resistors into a 3-ohm resistance, followed by the series combination of 3 ohms and 15 ohms. This 18-ohm resistance is finally combined in parallel with 2.25 ohms, and the circuit of Fig. 2-18b is obtained. Thus e is 10 volts, and the 3-amp source furnishes 30 watts to the remainder of the circuit.

Now if we are belatedly asked for the power dissipated in the 15-ohm resistor, we must return to the original circuit. This resistor is in series with an equivalent 3-ohm resistance; a voltage of 10 volts is across the 18-ohm total; thus, a current of $\frac{5}{9}$ amp flows through the 15-ohm resistor and the power absorbed by this element is $(\frac{5}{9})^2(15)$, or 4.63 watts.

To conclude the discussion of parallel and series element combinations, we should consider the parallel combination of two ideal voltage sources and the series combination of two ideal current sources. For instance, what is the equivalent of an ideal 5-volt source in parallel with an ideal 10-volt source? By the definition of an ideal voltage source, the voltage across the source cannot change; by Kirchhoff's voltage law, then, 5 equals 10 and we have hypothesized a physical impossibility. Thus, ideal voltage sources in parallel are permissible only when each has the same terminal voltage at every instant. Later, we shall see that *practical* voltage sources may be combined in parallel regardless of their terminal voltages and without any theoretical difficulty.

41 **Experimental Laws and Simple Circuits**

In a similar way, two ideal current sources may not be placed in series unless each has the same current, including sign, for every instant of time.

A voltage source in parallel or series with a current source presents an interesting little intellectual diversion. The two possible cases are illustrated by Prob. 29 at the end of the chapter.

Drill Problems

2-10 Determine the equivalent resistance of the networks shown in Fig. 2-19a, b, and c.

Ans. 375 ohms; 400 ohms; 275 ohms

2-11 Determine the equivalent resistance of the networks shown in Fig. 2-20a, b, and c.

Ans. 27 ohms; 16.25 ohms; 15.2 ohms

2-12 Find i_x in the circuits shown in Fig. 2-21a, b, and c.

Ans. 5 amp; -2 amp; 1.8 amp

2-13 Find e_x in the circuits shown in Fig. 2-22a, b, and c.

Ans. 5 volts; 4 volts; -2 volts

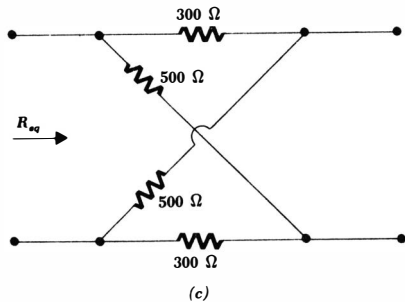
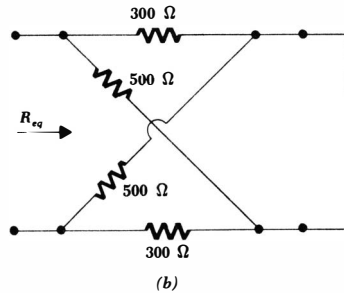
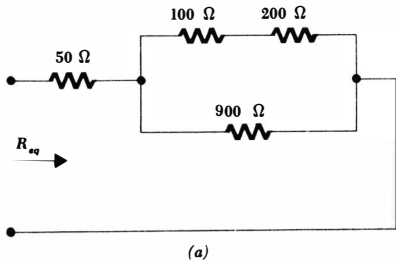

Fig. 2-19 See Drill Prob. 2-10.

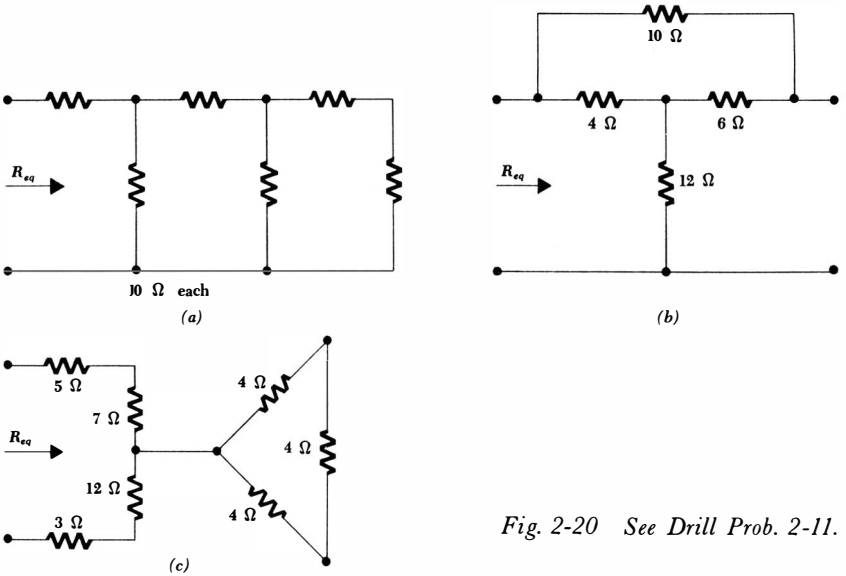
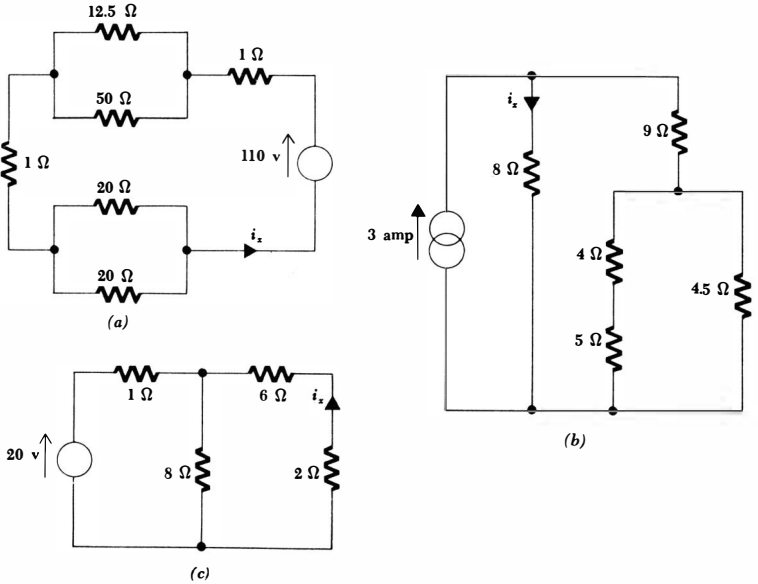

Fig. 2-20 See Drill Prob. 2-11.

Fig. 2-21 See Drill Probs. 2-12 and 2-15.



2-7 VOLTAGE AND CURRENT DIVISION

In combining resistances and sources, we have found one method of shortening the work of analyzing a circuit. Another useful shortcut is the application of the ideas of voltage and current division.

Voltage division occurs when an ideal voltage source is connected in series with two resistors, as illustrated in Fig. 2-23. The voltage across R_2 is obviously

$$e_2 = iR_2 = \frac{e}{R_1 + R_2} R_2$$

or
$$e_2 = \frac{R_2}{R_1 + R_2} e$$

and the voltage across R_1 is, similarly,

$$e_1 = \frac{R_1}{R_1 + R_2} e$$

The voltage appearing across either of the series resistors is the applied voltage times the ratio of that resistance to the total resistance. Voltage division

Fig. 2-22 See Drill Probs. 2-13 and 2-14.

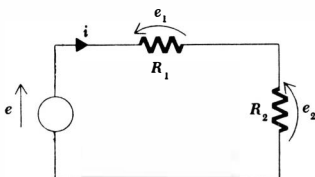
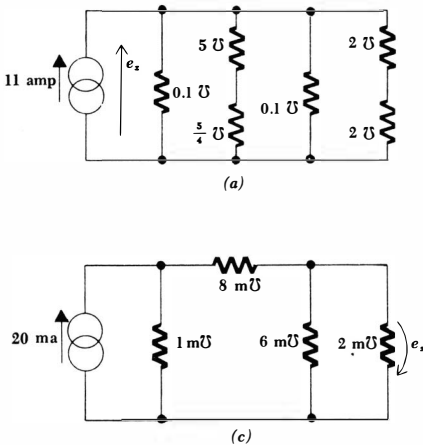
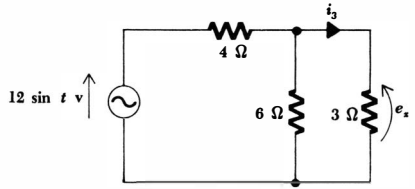

Fig. 2-23 An illustration of voltage division.

Fig. 2-24 A numerical example illustrating resistance combination and voltage division.



and resistance combination may both be applied, as in the circuit shown in Fig. 2-24. We mentally combine the 3- and 6-ohm resistances, obtaining 2 ohms, and thus find that e_x is $\frac{2}{12}$ of $12 \sin t$, or $4 \sin t$ volts.

The dual of voltage division is current division. We now are given a current source in parallel with two conductances, as exemplified by the circuit of Fig. 2-25. The current flowing through G_2 is

$$i_2 = eG_2 = \frac{i}{G_1 + G_2} G_2$$

or
$$i_2 = \frac{G_2}{G_1 + G_2} i$$

and, similarly,

$$i_1 = \frac{G_1}{G_1 + G_2} i$$

Thus the current flowing through either of the parallel conductances is the applied current times the ratio of that conductance to the total conductance.

Since we are given the value of the resistance more often than the conductance, a more important form of the last result is obtained by replacing G_1 by $1/R_1$ and G_2 by $1/R_2$,

$$i_2 = \frac{R_1}{R_1 + R_2} i \quad \text{and} \quad i_1 = \frac{R_2}{R_1 + R_2} i$$

Nature has not smiled on us here, for these last two equations have a factor which differs subtly from the factor used with voltage division, and some effort is going to be needed to avoid errors. Many students look on the expression for voltage division as "obvious" and that for current division as being "different."

It also helps to realize that the larger resistor always carries the smaller current.

As an example of the use of both current division and resistance combination,

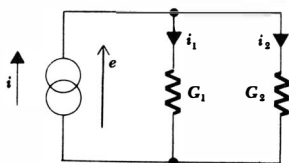

Fig. 2-25 An illustration of current division.

let us return to the example of Fig. 2-24 and write an expression for the current through the 3-ohm resistor. The total current flowing into the 3- and 6-ohm combination is

$$i = \frac{12 \sin t}{4 + (6)(3)/(6 + 3)}$$

and thus the desired current is

$$i_3 = \frac{12 \sin t}{4 + (6)(3)/(6 + 3)} \frac{6}{6 + 3} = \frac{2}{3} \sin t \quad \text{amp}$$

Drill Problems

2-14 Using voltage division and resistance combination, write directly the combination of numerical factors which will give the answer to each of the circuits of Fig. 2-22*a*, *b*, and *c*.

Ans. 5 volts; 4 volts; -2 volts

2-15 Using current division and resistance combination, write directly the combination of numerical factors which will give the answer to each of the circuits of Fig. 2-21*a*, *b*, and *c*.

Ans. 5 amp; -2 amp; 1.8 amp

Problems

- ◆1 A physical resistor often has a resistance which increases with temperature, and the temperature is a function of the power absorbed by it. As an example, suppose that $R = 1 + T/300$ and $T = 150p$, where T is in degrees centigrade and p is in watts. Find the resistance, temperature, and power when the current in the resistor is: (a) 0.1 amp; (b) 1.0 amp. (c) What finite current will produce an infinite temperature and, hence, certain destruction of the resistor? Find the resistance, temperature, and power when the voltage across the resistor is: (d) 1 volt; (e) 10 volts. (f) Show that no finite voltage will produce an infinite temperature.
- 2 Show that an ideal voltage source, $e_s = 100 \epsilon^{-t} \sin t$ connected to a 2000-ohm resistor is supplying powers of 26.2, 0, and 0.48 watt at $t = -1, 0$, and 1 sec, respectively.
- ◆3 Find R in the network of Fig. 2-26*a*.
- 4 The resistance of a conductor having a length d and a uniform cross-sectional area A may be expressed in terms of the electrical resistivity ρ (rho) or conductivity σ (sigma) of the material out of which it is made, provided that the current is uniformly distributed over the cross section. Thus, $R = \rho d/A = d/\sigma A$, where $\rho = 1/\sigma$. The conductivities of several common conducting materials are approximately: copper, 5.8×10^7 mhos/m; aluminum, 3.5×10^7 mhos/m; carbon, 2.9×10^4 mhos/m. (a) A copper strap 0.25 by 1 in. and 20 in. long carries a current of 200 amp. What is

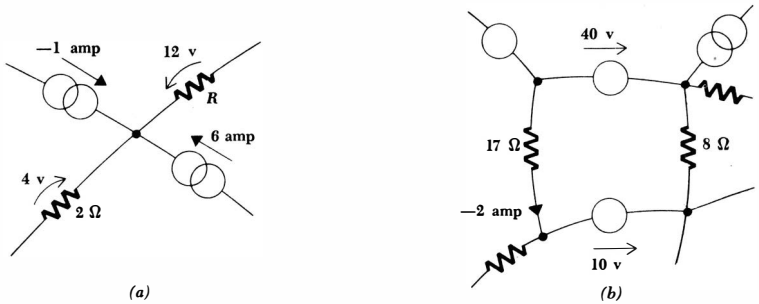

Fig. 2-26 (a) See Prob. 3. (b) See Prob. 6.

- the voltage between the two end faces of the strap? (b) An aluminum wire 5 miles long has a circular cross section of $\frac{1}{2}$ in. diameter. If the voltage between the ends of the wire should be no greater than 1 volt, what is the maximum current that the wire may carry? (c) Let us assume that one of Edison's early light bulbs was a 50-watt model operating from a 50-volt battery. If the carbon filament had a diameter of 0.5 mm, how many inches long was it? The resistivity of carbon at the temperature of the filament may be assumed to be twice its room-temperature value, as given above.
- 5 Experimental measurements show that the total charge which has entered terminal 1 of a 10-ohm resistor between $t = 0$ and t is:

t , seconds	0	1	2	3	4
q , coulombs	0	1.05	2.20	3.45	4.80

- (a) Determine $i(t)$, the current entering terminal 1, approximately at $t = 1, 2, 3,$ and 4 by considering the charge transferred during the previous 1-sec interval. (b) The relationship between $q(t)$ and $i(t)$ is $q = t + 0.05t^2$. Determine $i(t)$ at $t = 0, 1, 2, 3,$ and 4 . (c) Find the power being delivered to the resistor at $t = 1, 2, 3,$ and 4 . (d) Determine the total energy delivered to the resistor between $t = 0$ and $t = 4$.

Fig. 2-27 (a) See Prob. 7. (b) See Prob. 8.

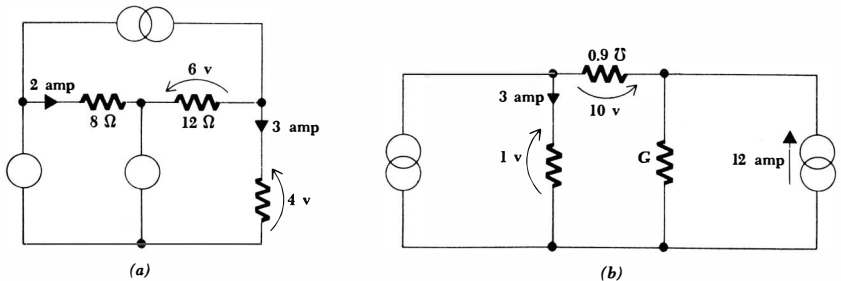

- ◆6 Find the power delivered to the 8-ohm resistor in the network of Fig. 2-26*b*.
- 7 In the circuit of Fig. 2-27*a*: (a) find the total power delivered to the three resistors; (b) use Ohm's law and Kirchhoff's current law to find the current in each branch; (c) use Ohm's law and Kirchhoff's voltage law to find the voltage across each branch; (d) find the power delivered by each source.
- ◆8 (a) Find G in the circuit of Fig. 2-27*b*. (b) Determine the currents and voltages throughout this circuit. (c) Find the power absorbed in each of the five branches.
- 9 Apply Kirchhoff's laws to the networks shown in Fig. 2-28*a* and *b* and determine i_x and e_x at $t = 1$ msec.
- ◆10 An automobile storage battery is being charged by a battery charger. The circuit consists of the series combination of the battery charger, which is represented by a 15-volt ideal source in series with a resistance of 0.1 ohm, an adjustable series resistor R , and the battery to be charged, represented by an 11-volt ideal source in series with a resistance of 0.3 ohm. The sources oppose each other. (a) Determine R so that a charging current of 3 amp flows. (b) What fraction of the power produced by the ideal 15-volt source is delivered to the ideal 11-volt source? (c) What fraction is lost in the internal resistance of the charger (0.1 ohm) and the battery (0.3 ohm)? (d) What is the voltage across the series combination of the battery and its internal resistance?
- 11 A certain 10-watt electrical device draws 2 amp. (a) If it is operating 200 ft from a 6-volt source, what is the wire resistance in ohms per foot? (b) Locate a "wire table" and determine the gage number of the annealed copper wire which has a resistance per foot equal to or just less than this value.
- ◆12 (a) Determine the voltage across, the current through, and the power delivered to each element in the circuit of Fig. 2-29*a*. (b) How does doubling the voltage of every source affect the answers? (c) How does doubling the resistance of every resistor affect the answers?
- 13 Repeat Prob. 12, part a, for the circuit of Fig. 2-29*b*.

Fig. 2-28 See Prob. 9.

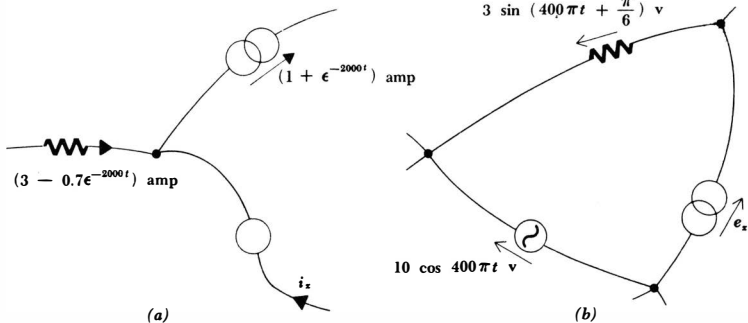

- 14 In the circuit shown in Fig. 2-30, it is not known whether the element at the left is a resistor, a current source, or a voltage source. (a) Determine the voltage across, the current through, and the power absorbed by each element. (b) Specify whether the unknown element is furnishing or absorbing power; if it is absorbing power, determine its proper characteristics as a resistor, as an ideal voltage source, and as an ideal current source; if it is delivering power, specify it completely as an ideal voltage source and an ideal current source. (c) Change “8 v” to “-8 v” and repeat parts a and b above.
- 15 In the next chapter we will study the superposition theorem. It states that the response of a circuit containing several sources is the sum of the responses to the individual sources. Consider the simple circuit shown in Fig. 2-31. (a) Replace e_{s2} by a short circuit (a perfectly conducting wire), and determine the resultant current i_1 . (b) Replace e_{s2} and insert a short circuit for e_{s1} . Find the current i_2 due to e_{s2} . (c) With both sources

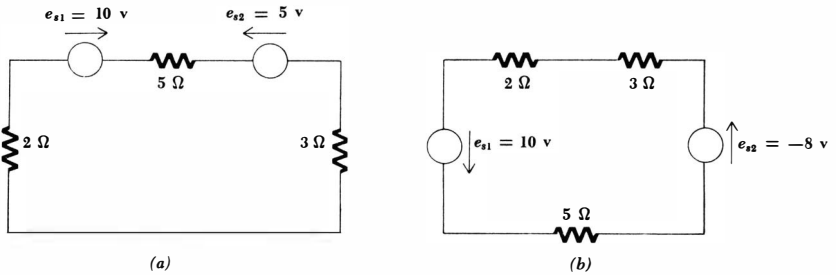

Fig. 2-29 (a) See Prob. 12. (b) See Prob. 13.

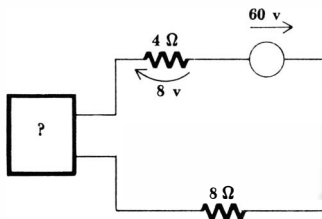

Fig. 2-30 See Prob. 14.

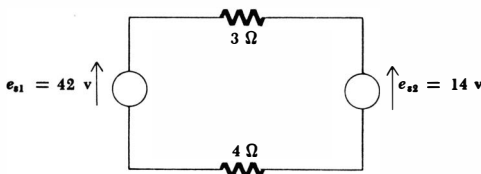

Fig. 2-31 See Prob. 15.

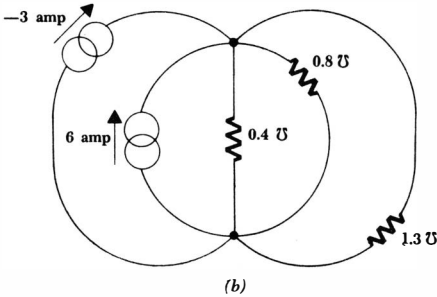
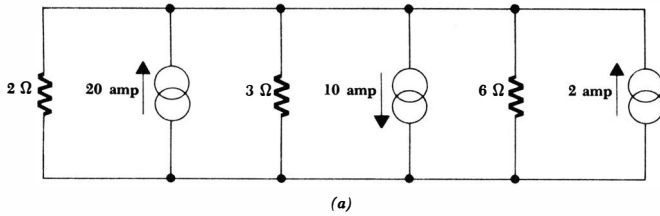

Fig. 2-32 (a) See Prob. 17. (b) See Prob. 18.

operating, “both currents” are now flowing. Indicate these two currents by two adjacent arrowheads, correctly sensed and labeled i_1 and i_2 . (d) Add i_1 and i_2 algebraically and indicate this total current on the circuit diagram. (e) Apply Kirchoff’s and Ohm’s laws to the original circuit and check your answer for the total current.

- ◆16 An ideal 100-volt source is in series with a 100-ohm resistor and a resistor R_1 . Determine the power delivered to R_1 if R_1 is: (a) 1, 10, 50, 100, 200, 1000 ohms, and just R_1 ohms. (b) Determine analytically the value of R_1 which will absorb a maximum power. (c) Is this value of resistance affected by e_s , the source voltage? (d) Is this value affected by the value of the series resistor, here 100 ohms? (e) Repeat part b, using e_s and R_s instead of 100 volts and 100 ohms.
- ◆17 Determine the voltage across, the current through, and the power delivered to each element in the circuit of Fig. 2-32a.
- 18 Repeat Prob. 17 for the circuit of Fig. 2-32b.
- ◆19 With reference to the circuit of Fig. 2-33a: (a) How many nodes are present? (b) What is e_{14} ? (c) What power is absorbed by the 0.3-mho conductance? (d) What power is delivered by the 10-amp source? (e) What power is delivered by the 1-ohm resistor? (f) What is i_2 ?
- 20 Repeat Prob. 14 for the circuit of Fig. 2-33b.
- 21 A power of 200 watts is to be delivered to the 50-ohm resistors shown in Fig. 2-34a and b. (a) Find e_s and i_s . (b) Find the power furnished by the ideal voltage source. (c) Find the power furnished by the ideal current source. (d) Find the power dissipated in each 10-ohm resistor.
- ◆22 Find the voltage across each source in the circuits of Fig. 2-35.

50 **The Resistive Circuit**

- 23 Find the current through the 2-ohm resistor of Fig. 2-36.
- ◆24 Find the equivalent resistance and equivalent conductance of the networks shown in Fig. 2-37a and b, respectively.
- 25 Find the equivalent resistance of each network shown in Fig. 2-38.
- ◆26 The network shown in Fig. 2-39a continues to the right in the same form without end. Find the equivalent resistance.

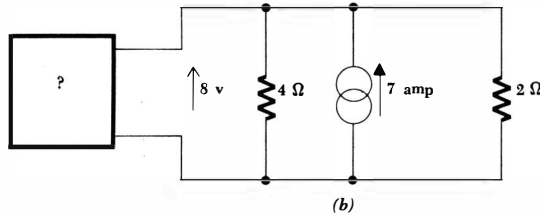
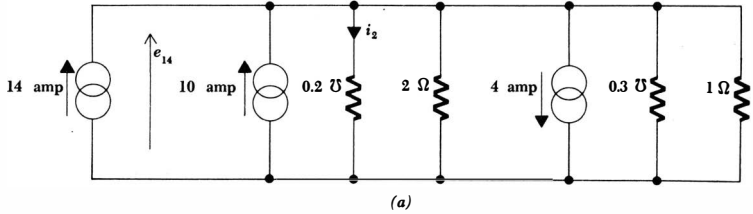

Fig. 2-33 (a) See Prob. 19. (b) See Prob. 20.

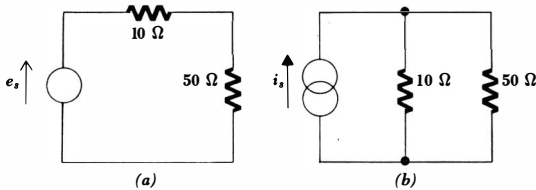
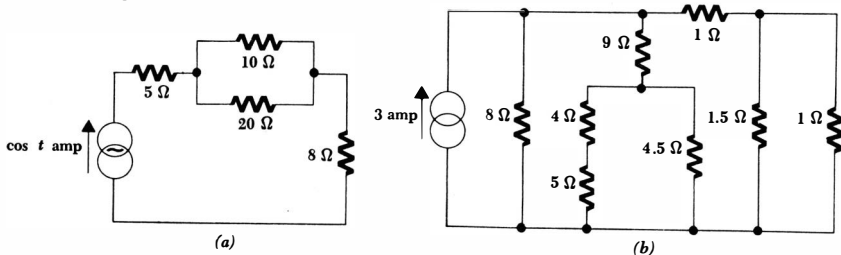

Fig. 2-34
See Prob. 21.

Fig. 2-35 See Prob. 22.



51 **Experimental Laws and Simple Circuits**

- 27 In the network of Fig. 2-39b, determine e and i if a current of 1 amp is flowing to the right in the 1-ohm resistor.
- ◆ 28 Find i_1 , i_2 , and the power delivered by the source in the circuit of Fig. 2-40.
- 29 Find the power absorbed by each element in the circuit of Fig. 2-41.

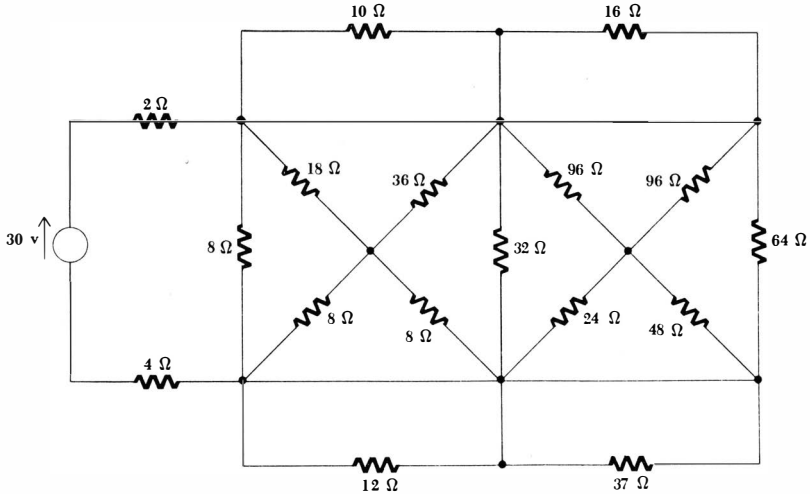

Fig. 2-36 See Prob. 23.

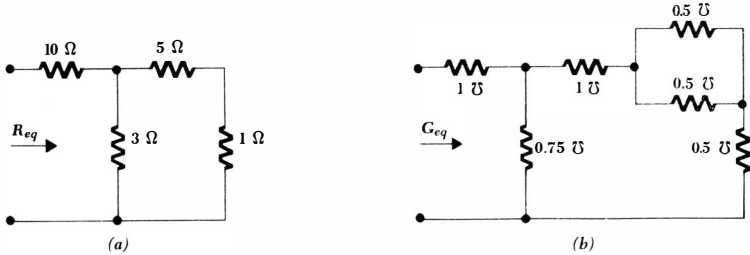
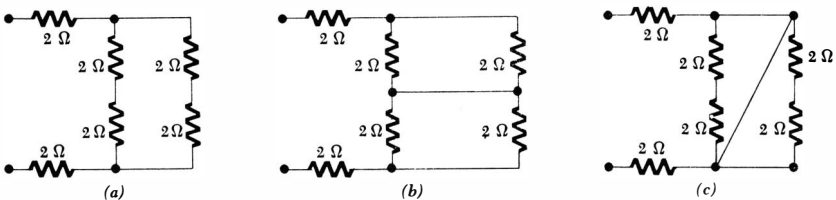

Fig. 2-37 See Prob. 24.

Fig. 2-38 See Prob. 25.



52 The Resistive Circuit

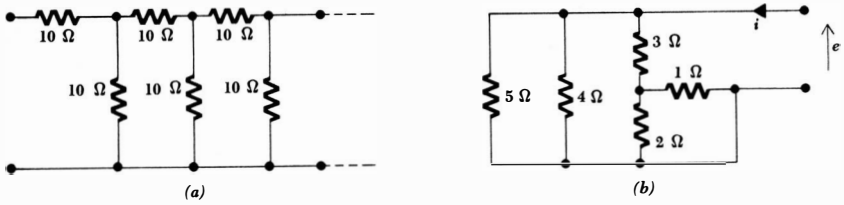

Fig. 2-39 (a) See Prob. 26. (b) See Prob. 27.

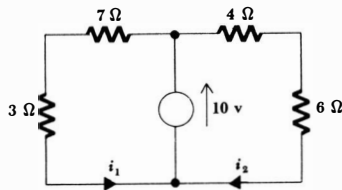

Fig. 2-40 See Prob. 28.

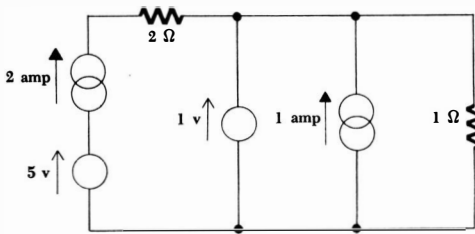

Fig. 2-41 See Prob. 29.

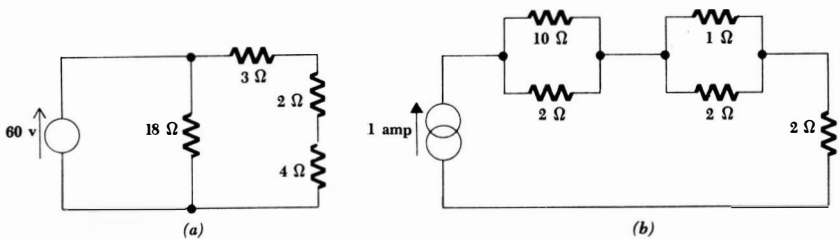

Fig. 2-42 (a) See Prob. 30. (b) See Prob. 31.

- ◆30 Find, in one calculation each, the voltage, current, and power associated with the 2-ohm resistor of Fig. 2-42a.
- 31 Repeat Prob. 30 for each 2-ohm resistor of Fig. 2-42b.
- ◆32 A 10-volt source, a 4-ohm resistor, an 8-ohm resistor, and the parallel combination of a 6-ohm and 12-ohm resistor are all in series. What power is delivered to the 6-ohm resistor?

53 *Experimental Laws and Simple Circuits*

- 33 Find the power delivered to each 12-ohm resistor in the circuits of Fig. 2-43*a* and *b*.
- 34 As a simple illustration of the difference between analysis and synthesis, consider the following two problems. The first has only one answer, and the second has an infinite number of answers. (a) A 100-volt ideal d-c source is in series with a 10-ohm and a 30-ohm resistor. Determine the power delivered to the 30-ohm resistor. (b) Eight small identical light bulbs are each to receive 5 watts. Design a circuit to do this, using only one voltage source. (The resistance of a lamp filament increases as the current through it increases. For the purposes of this problem, however, assume that the lamp obeys Ohm's law for all voltages and currents.)
- ◆35 Find the value of R in the circuit shown in Fig. 2-43*c*.
- 36 Either circuit of Fig. 2-44 may be used to measure resistance experimentally by the voltmeter-ammeter method. If the meters are ideal, the resistance R is given by the quotient of the voltmeter and ammeter readings. However, practical voltmeters are closely represented by a resistance R_v in parallel with an ideal (infinite-resistance) voltmeter and practical ammeters by a resistance R_a in series with an ideal (zero-resistance) ammeter. Assume that the practical meters read E and I ; the quotient is now not equal to R , but an error term is present, $E/I = R + R_{\text{error}}$. (a) Calculate R_{error} for both circuits. (b) Determine R in terms of R_v and R_a so that the magnitudes of the errors in the two circuits are the same. (c) If $R_v = 1200$ ohms and $R_a = 12$ ohms, which circuit will give the better accuracy if R is about 50 ohms?

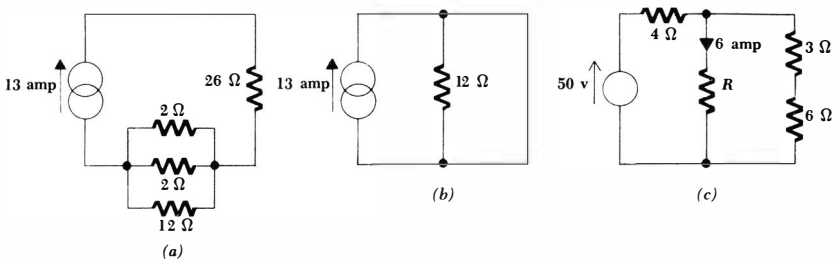
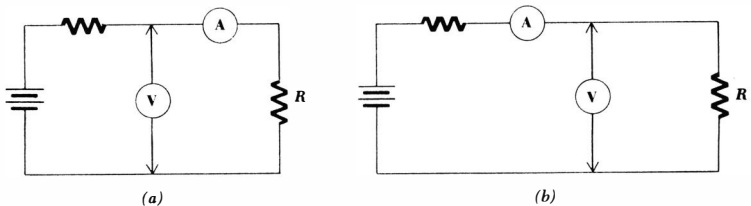

Fig. 2-43 (a) and (b) See Prob. 33. (c) See Prob. 35.

Fig. 2-44 See Prob. 36.



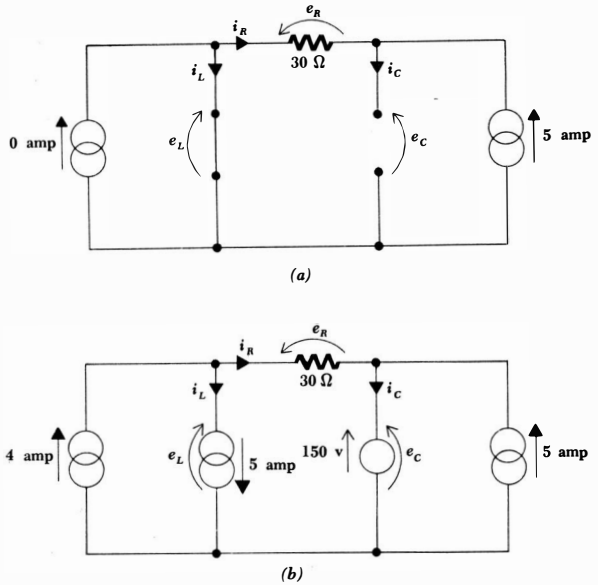

Fig. 2-45 See Prob. 37.

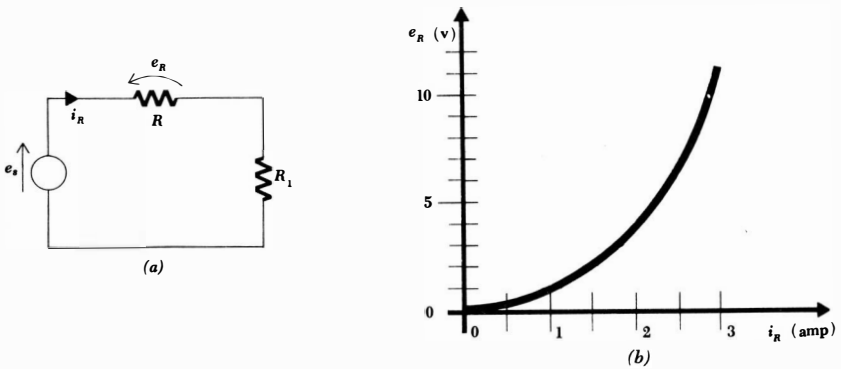

Fig. 2-46 See Prob. 38.

- ◆37 The circuits shown in Fig. 2-45 appear in an example used in Sec. 8-7. Find e_R , i_R , e_L , i_L , e_C , and i_C in each circuit.
- 38 The circuit of Fig. 2-46a contains a nonlinear resistor R in series with a voltage source and a linear resistor R_1 . The relationship between e_R and i_R is shown graphically in Fig. 2-46b. (a) If e_s is 8 volts and R_1 is 8 ohms, find i_R and the power absorbed by each of the three elements in the circuit. (b) Repeat for $e_s = 12$ volts and $R_1 = 4$ ohms.

Chapter 3 *Some Useful Techniques of Circuit Analysis*

3-1 INTRODUCTION

We should now be familiar with Ohm's law and Kirchhoff's laws and their application in the analysis of simple series and parallel resistive circuits. Furthermore, we should be able to combine resistances or sources when they appear in series or parallel and be able to use the principles of voltage and current division when they will produce answers more easily. The circuits on which we have been practicing are simple and of questionable practical importance; they are useful in helping us learn to apply the fundamental laws. Now we must begin solving more complicated circuits.

Physical systems which we shall want to analyze and design in the coming years will include electric and electronic control circuits, electrical communication systems, electrical energy converters such as motors and generators, and electric power distribution systems. Many of us will be confronted with allied problems involving heat flow, fluid flow, and the behavior of various mechanical systems. In the analysis of any of these cases it is often helpful to replace the system with an equivalent electric circuit. As an example, we might consider a transistor amplifier, an electronic device which is a part of many communication systems and control circuits. The transistor, along with several resistors and other passive circuit elements, is used to amplify or magnify an electrical signal and to direct the amplified signal to a desired load. It is possible to replace the transistor, the resistors, the other passive circuit elements, the signal source, and the load by combinations of simple circuit elements, such as ideal current sources, ideal voltage sources, and ideal resistors. The solution of the problem is then achieved by circuit methods and techniques which we either know already or will meet in this chapter.

In a similar way, we can replace complicated power distribution systems, motors, generators, and electrical transmission lines with equivalent circuits composed of simple circuit elements.

When we are able to describe mathematically the behavior of fluid-flow and heat-flow systems, the dynamic response of aircraft control surfaces, and other nonelectrical phenomena, we shall see that the resultant equations are often precisely analogous to those describing current and voltage relationships in electric circuits. We may decide, then, that it is much easier and cheaper to construct the analogous electric circuit than it is to build a prototype of the actual physical system. The electric circuit may then be used to predict the performance of the other system as various elements are changed and will lead to a better final design. This is the basis on which the electronic analog computer operates.

It is evident that one of the primary goals of this chapter must be learning methods of simplifying the analysis of more complicated circuits. Among these methods will be superposition, mesh analysis, and nodal analysis. Most often we are interested only in the detailed performance of an isolated portion of a complex circuit; a method of replacing the remainder of the circuit by a greatly simplified equivalent is then very desirable. The equivalent is often a single resistor in series or parallel with an ideal source. Thevenin's and Norton's theorems will enable us to do this.

We shall begin studying methods of simplifying circuit analysis by considering a powerful general method, that of mesh analysis.

3-2 MESH ANALYSIS

In the first chapter, a circuit was defined as a network containing at least one *closed path* about which current might flow. The official name for this closed path is a *loop*. Thus, if we begin at a certain node and trace a continuous closed path through the network, passing through no node or element more than once and ending at the same node, that path is a *loop*. Figure 3-1 shows several examples. The particular paths considered are those which are drawn with heavy lines, and it is evident that the first two paths cannot be loops since the path either is not closed or passes through a node twice. The remaining four paths are all loops. The circuit contains 11 branches.

Now let us consider this same circuit drawn differently so that one of the branches passes over another without making any connection with it, as shown in Fig. 3-2. Such a network is said to be drawn in *nonplanar* form, whereas the circuit shown in Fig. 3-1 is drawn in *planar* form. The mesh is a property of a planar circuit and is not defined for a nonplanar circuit. We define a *mesh* as a loop which does not contain any other loops within it. Thus, the loops indicated in Fig. 3-1*c* and *d* are not meshes, whereas those of *e* and *f* are meshes. This circuit contains four meshes. Although it may appear to be splitting hairs, we choose to describe the closed path of Fig. 3-2 as a loop *but not a mesh*. By merely redrawing the circuit, as shown in Fig. 3-1*f*, the loop becomes a mesh.

Thus, it is seen that meshes are a property of networks which are drawn in planar form, and they cannot be identified until the network is drawn in planar form. This is not always possible. For example, the circuit of Fig. 3-3*a* can be redrawn in planar form, but the one shown in Fig. 3-3*b* cannot, and hence the method of mesh analysis is not applicable to it.

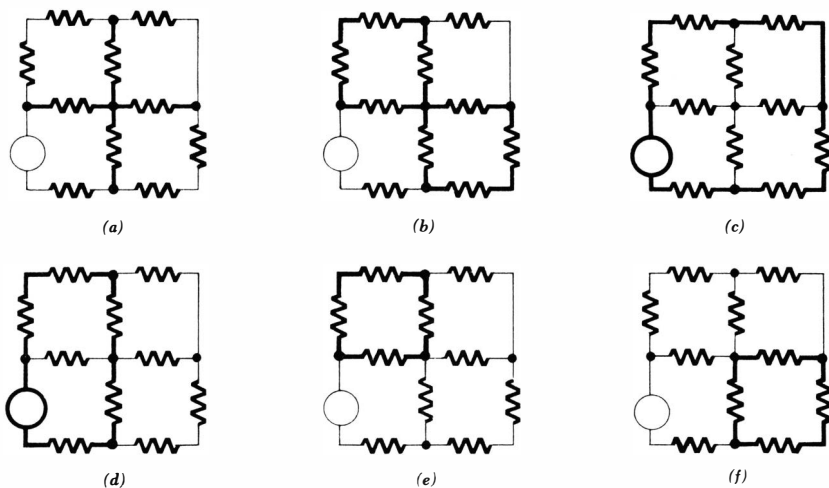

Fig. 3-1 (a) The path identified by the heavy line is not a loop since it is not closed. (b) The path here is not a loop since it passes through the central node twice. (c) This path is a loop but not a mesh since it encloses other loops. (d) This path is also a loop but not a mesh. (e) and (f) Each of these paths is both a loop and a mesh.

In order to identify the meshes in a given circuit, it is necessary first to draw the circuit in planar form, if it is not already in that form, and if it is possible to do so. If the network cannot be placed in planar form, then the method of mesh analysis is not applicable. In Chap. 18 we shall find that loop analysis is applicable to nonplanar circuits.

We are now prepared to introduce the concept of a *mesh current*, and we shall do so by considering the analysis of the two-mesh circuit shown in Fig. 3-4a. As we did in the single-loop circuit, we shall begin by assuming a current through one of the branches. Let us call the current flowing to the right through the 6-ohm resistor i_1 . We intend to apply Kirchhoff's voltage law

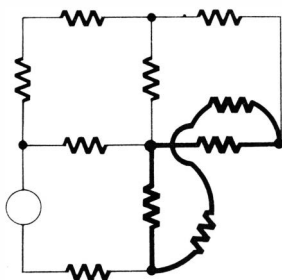

Fig. 3-2 The circuit of Fig. 3-1(f) is redrawn as a nonplanar network. The closed path indicated is a loop but not a mesh.

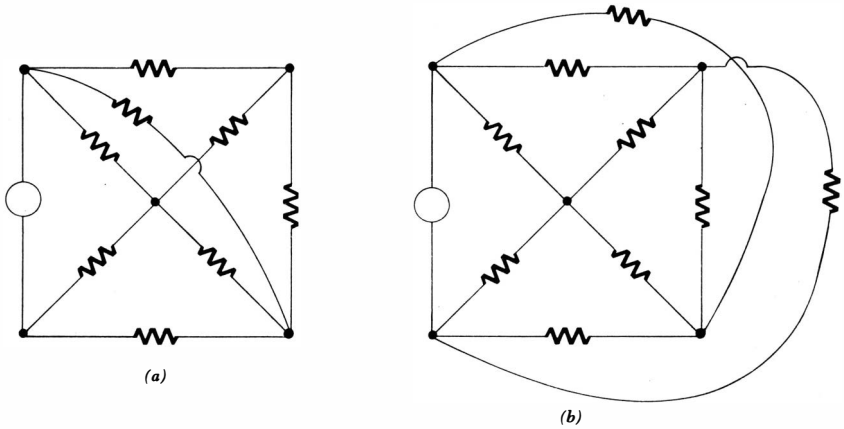

Fig. 3-3 The circuit of (a) can be redrawn in planar form but the circuit of (b) cannot be redrawn in planar form.

around each of the two meshes, and the resulting two equations are sufficient to determine two unknown currents. Therefore we select a second current i_2 flowing to the right in the 4-ohm resistor. We might also choose to call the current flowing downward through the central branch i_3 , but it is evident from Kirchhoff's current law that i_3 may be expressed in terms of the two previously assumed currents as $(i_1 - i_2)$. Finally, it may be helpful to indicate the voltage across each resistor by using an appropriately sensed and labeled arrow. The assumed currents and the resultant voltages are shown in Fig. 3-4b.

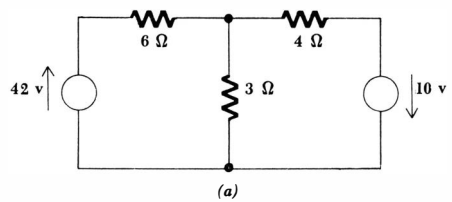
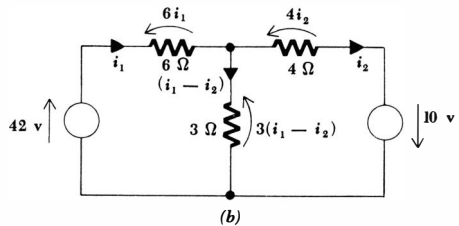

Fig. 3-4 (a) A given two-mesh circuit. (b) Two currents are assumed, and the current through and voltage across every element are indicated in terms of these two assumed currents.



Following the method of solution for the single-loop circuit, we now apply Kirchhoff's voltage law to the left-hand mesh,

$$\begin{aligned} -42 + 6i_1 + 3(i_1 - i_2) &= 0 \\ \text{or} \qquad \qquad \qquad 9i_1 - 3i_2 &= 42 \end{aligned} \tag{3-1}$$

and then to the right-hand mesh,

$$\begin{aligned} -3(i_1 - i_2) + 4i_2 - 10 &= 0 \\ \text{or} \qquad \qquad \qquad -3i_1 + 7i_2 &= 10 \end{aligned} \tag{3-2}$$

Equations (3-1) and (3-2) are independent equations; one cannot be derived from the other.¹ There are two equations and two unknowns, and the solution is easily obtained by a systematic elimination of the variables. The solution shows that i_1 is 6 amp, i_2 is 4 amp, and $(i_1 - i_2)$ is therefore 2 amp. The voltage and power relationships may be quickly obtained if desired.

If our circuit had contained M meshes, then we should have had to assume M branch currents and write M independent equations.² The solution in general may be systematically obtained through the use of determinants, a procedure which will be described in the following section.

Now let us consider this same problem in a slightly different manner by using mesh currents. We define a *mesh current* as a current which flows only around the perimeter of a mesh. If we label the left-hand mesh of our problem as mesh 1, then we may establish a mesh current i_1 flowing in a clockwise direction about this mesh. A mesh current is indicated by a curved arrow that almost closes on itself and is drawn inside the appropriate mesh, as shown in Fig. 3-5. The mesh current i_2 is established in the remaining mesh, again in a clockwise direction. Although the direction is arbitrary, we shall always choose clockwise mesh currents because a certain error-minimizing symmetry then results in the equations.

We no longer have a current or current arrow shown directly on each branch in the circuit. The current through any branch must be determined by considering the mesh currents flowing in every mesh in which that branch appears. This is not difficult because it is obvious that no branch can appear in more than two meshes. For example, the 3-ohm resistor appears in both meshes, and the current flowing downward through it is $(i_1 - i_2)$. The 6-ohm resistor ap-

¹ It will be shown in Chap. 18 that mesh equations are always independent.

² The proof of this statement will also be found in Chap. 18.

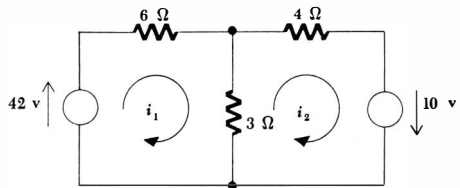

Fig. 3-5 A clockwise mesh current is indicated in each mesh.

pears only in mesh 1, and the current flowing to the right in that branch is equal to the mesh current i_1 .

A mesh current may often be identified as a branch current, as i_1 and i_2 are identified above. This is not always true, however, for consideration of a square nine-mesh network soon shows that the central mesh current cannot be identified as the current in any branch.

One of the greatest advantages in the use of mesh currents is the fact that Kirchhoff's current law is automatically satisfied. If a mesh current flows into a given node, it obviously flows out of it also.

We therefore may turn our attention to the application of Kirchhoff's voltage law to each mesh. For the left-hand mesh,

$$\begin{aligned} -42 + 6i_1 + 3(i_1 - i_2) &= 0 \\ \text{or} \quad (6i_1 + 3i_1) + (-3i_2) &= 42 \end{aligned}$$

Either equation is equivalent to Eq. (3-1), but the form of the lower equation has been written in such a way as to display in the first parentheses all the passive-element voltages due to i_1 , those due to i_2 in the second parentheses, and the sum of the voltage sources in the mesh on the right side of the equation. Now let us combine the like terms, which gives us Eq. (3-1) identically, and point out specifically the nature of each sign and coefficient appearing in the equation:

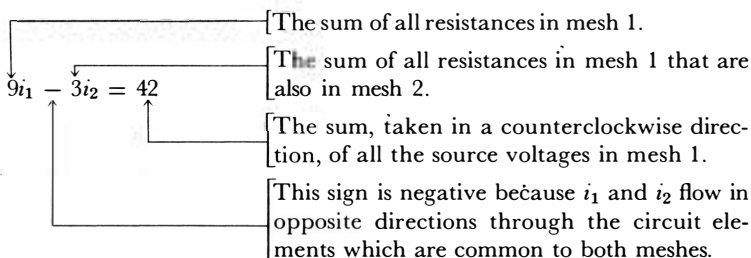

Let us use the symbol R_{11} to represent the sum of all the resistances in mesh 1; thus, $R_{11} = 9$ ohms. In general, R_{jj} represents the sum of all the resistances in mesh j . This total resistance is called the *self-resistance* of the mesh.

In an analogous way, R_{12} is defined as the sum of all the resistances in mesh 1 which are common to mesh 2; $R_{12} = 3$ ohms. It is evident that R_{21} is also 3 ohms and that in general $R_{jk} = R_{kj}$. This common resistance is called the *mutual resistance* between the two-meshes.

Finally, let us call the counterclockwise sum of all the voltages in the j th mesh e_j . In the circuit under discussion, $e_1 = 42$ volts and $e_2 = 10$ volts.

For mesh 1 we may therefore write

$$R_{11}i_1 - R_{12}i_2 = e_1$$

and the corresponding expression for mesh 2 must be

$$-R_{21}i_1 + R_{22}i_2 = e_2$$

We have already noted that R_{21} must be 3 ohms, and a quick glance at the cir-

circuit shows that the total resistance around the second mesh is 7 ohms and the total source voltage acting around that mesh is 10 volts. Hence,

$$-3i_1 + 7i_2 = 10$$

As a final example of the choice of mesh currents and the writing down by inspection of the necessary set of equations, let us consider the three-mesh circuit of Fig. 3-6. The three necessary mesh currents are indicated, and the general form of the three equations is

$$\begin{aligned} R_{11}i_1 - R_{12}i_2 - R_{13}i_3 &= e_1 \\ -R_{21}i_1 + R_{22}i_2 - R_{23}i_3 &= e_2 \\ -R_{31}i_1 - R_{32}i_2 + R_{33}i_3 &= e_3 \end{aligned}$$

The nine resistance values and the three source-voltage sums are read off the circuit, and the equations to be solved are thus

$$\begin{aligned} 3i_1 - i_2 - 2i_3 &= 1 \\ -i_1 + 6i_2 - 3i_3 &= 0 \\ -2i_1 - 3i_2 + 6i_3 &= 6 \end{aligned}$$

We should become familiar enough with mesh analysis that such a set of equations may be written down by inspection after assigning mesh currents to the circuit.

It should be noted in each of the above three equations that the only term on the left side with a positive coefficient is that one due to the mesh current flowing about that mesh to which Kirchhoff's voltage law is being applied; all the terms resulting from other mesh currents are negative. This is the reason for choosing all mesh currents in the same (clockwise) direction. A similar distribution of signs will occur in the equations applying to a circuit containing any number of meshes if clockwise mesh currents are chosen.

To summarize the method of mesh analysis, the following steps may be listed to be taken in order:

1. Draw the circuit in planar form. If this is impossible, mesh analysis is not applicable.

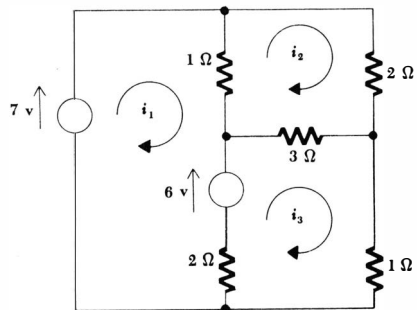

Fig. 3-6 A three-mesh circuit.

63 *Some Useful Techniques of Circuit Analysis*

and a system of three equations for the three-mesh circuit of Fig. 3-6,

$$3i_1 - i_2 - 2i_3 = 1 \tag{3-3}$$

$$-i_1 + 6i_2 - 3i_3 = 0 \tag{3-4}$$

$$-2i_1 - 3i_2 + 6i_3 = 6 \tag{3-5}$$

The system of two equations was solved easily by eliminating one of the current variables; the other set was left unsolved, although a systematic elimination of the variables will certainly work. This procedure is lengthy, however, and may never yield answers if done unsystematically. A much more orderly method involves using determinants and Cramer's rule, as discussed in most courses in college algebra. The use of determinants has the additional advantages that it leads naturally into the expression of the circuit elements in terms of matrices, and it establishes a method of analyzing a general circuit which will be helpful in proving general theorems. It should be pointed out that the number of arithmetic steps required to solve a large set of simultaneous equations by determinants is excessive; a digital computer would be programmed to use another method. This section consists of a brief review of the determinant method and the introduction of a system of nomenclature which we shall then preserve.

Consider Eqs. (3-3), (3-4), and (3-5). The array of the constant coefficients of the equations is called a determinant Δ_r ,

$$\Delta_r = \begin{vmatrix} 3 & -1 & -2 \\ -1 & 6 & -3 \\ -2 & -3 & 6 \end{vmatrix}$$

where the r subscript is a reminder that the numbers appearing in Δ_r are all combinations of resistances only. The value of any determinant is obtained by expanding it in terms of its minors. To do this, we select any row j or any column k , multiply each element in that row or column by its minor and by $(-1)^{j+k}$, and then add these products. The *minor* of the element appearing in both row j and column k is the determinant which is obtained when row j and column k are removed.

As an example, let us expand the determinant along column 3. We first multiply the (-2) at the top of this column by $(-1)^{3+1} = 1$ and then by its minor,

$$(-2)(-1)^{3+1} \begin{vmatrix} -1 & 6 \\ -2 & -3 \end{vmatrix}$$

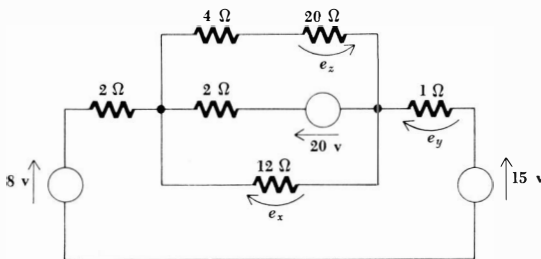

Fig. 3-8 See Drill Prob. 3-2.

64 The Resistive Circuit

and then repeat for the other two elements in column 3, adding the results,

$$\Delta_r = (-2) \begin{vmatrix} -1 & 6 \\ -2 & -3 \end{vmatrix} - (-3) \begin{vmatrix} 3 & -1 \\ -2 & -3 \end{vmatrix} + 6 \begin{vmatrix} 3 & -1 \\ -1 & 6 \end{vmatrix}$$

The minors now contain only two rows and columns. They are of *order* two, and their values are easily determined by expanding in terms of minors again, here a trivial operation. Thus, for the first determinant, we expand along the first column by multiplying (-1) by $(-1)^{1+1}$ and its minor, which is merely the element (-3) , and then multiplying (-2) by (-1) and by 6. Thus,

$$\begin{vmatrix} -1 & 6 \\ -2 & -3 \end{vmatrix} = (-1)(-3) - 6(-2) = 15$$

It is usually easier to remember the result for a second-order determinant as "upper left times lower right minus upper right times lower left." Finally,

$$\begin{aligned} \Delta_r &= -2[(-1)(-3) - 6(-2)] + 3[3(-3) - (-1)(-2)] \\ &\quad + 6[3(6) - (-1)(-1)] \\ &= -2(15) + 3(-11) + 6(17) \\ &= 39 \end{aligned}$$

For practice, let us expand this same determinant along the first row,

$$\begin{aligned} \Delta_r &= 3 \begin{vmatrix} 6 & -3 \\ -3 & 6 \end{vmatrix} - (-1) \begin{vmatrix} -1 & -3 \\ -2 & 6 \end{vmatrix} + (-2) \begin{vmatrix} -1 & 6 \\ -2 & -3 \end{vmatrix} \\ &= 3(27) + 1(-12) - 2(15) \\ &= 39 \end{aligned}$$

The expansion by minors is valid for a determinant of any order.

We next consider Cramer's rule, which enables us to find the values of the unknown currents. Let us again consider Eqs. (3-1), (3-2), and (3-3); we define the determinant Δ_1 as that determinant which is obtained when the first column of Δ_r is replaced by the three constants on the right sides of the three equations, e_1 , e_2 , and e_3 . Thus,

$$\Delta_1 = \begin{vmatrix} 1 & -1 & -2 \\ 0 & 6 & -3 \\ 6 & -3 & 6 \end{vmatrix}$$

In order to take advantage of the zero, we may expand along the first column (although row 2 would be just as convenient),

$$\Delta_1 = 1 \begin{vmatrix} 6 & -3 \\ -3 & 6 \end{vmatrix} + 6 \begin{vmatrix} -1 & -2 \\ 6 & -3 \end{vmatrix} = 1(27) + 6(15) = 117$$

Cramer's rule then states that

$$i_1 = \frac{\Delta_1}{\Delta_r} = \frac{117}{39} = 3 \text{ amp}$$

$$\text{and } i_2 = \frac{\Delta_2}{\Delta_r} = \frac{\begin{vmatrix} 3 & 1 & -2 \\ -1 & 0 & -3 \\ -2 & 6 & 6 \end{vmatrix}}{39} = \frac{12 + 66}{39} = 2 \text{ amp}$$

$$\text{and finally, } i_3 = \frac{\Delta_3}{\Delta_r} = \frac{\begin{vmatrix} 3 & -1 & 1 \\ -1 & 6 & 0 \\ -2 & -3 & 6 \end{vmatrix}}{39} = \frac{15 + 102}{39} = 3 \text{ amp}$$

Let us now consider the circuit of Fig. 3-9. This circuit has four meshes, and the necessary four mesh currents are selected in a clockwise direction as shown. Rather than write the four needed equations, we might try to write down the determinants we have to evaluate, directly from the circuit. Along the principal diagonal of Δ_r , which extends from the upper-left to the lower-right corner, the values of R_{11} , R_{22} , R_{33} , and R_{44} are placed. All are positive and can be read from the circuit diagram. Off the principal diagonal, all the numbers must be negative since we have selected all mesh currents clockwise. These values of mutual resistance are also quite apparent in the circuit, and thus

$$\begin{aligned} i_1 &= \frac{\begin{vmatrix} 100 & -10 & 0 & 0 \\ 0 & 15 & -3 & 0 \\ 0 & -3 & 16 & -12 \\ 200 & 0 & -12 & 14 \end{vmatrix}}{\begin{vmatrix} 11 & -10 & 0 & 0 \\ -10 & 15 & -3 & 0 \\ 0 & -3 & 16 & -12 \\ 0 & 0 & -12 & 14 \end{vmatrix}} \\ &= \frac{100 \begin{vmatrix} 15 & -3 & 0 \\ -3 & 16 & -12 \\ 0 & -12 & 14 \end{vmatrix} - 200 \begin{vmatrix} -10 & 0 & 0 \\ 15 & -3 & 0 \\ -3 & 16 & -12 \end{vmatrix}}{11 \begin{vmatrix} 15 & -3 & 0 \\ -3 & 16 & -12 \\ 0 & -12 & 14 \end{vmatrix} + 10 \begin{vmatrix} -10 & 0 & 0 \\ -3 & 16 & -12 \\ 0 & -12 & 14 \end{vmatrix}} \\ &= \frac{100[15(224 - 144) + 3(-42)] - 200[-10(36)]}{11[15(224 - 144) + 3(-42)] + 10[-10(224 - 144)]} \\ &= 47.0 \text{ amp} \end{aligned}$$

Fig. 3-9 A four-mesh circuit.

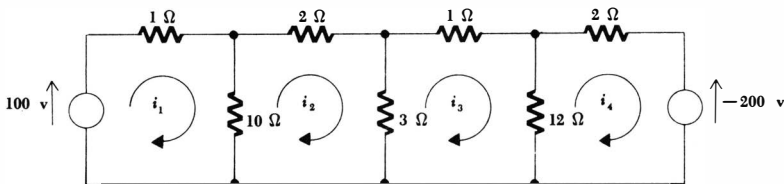

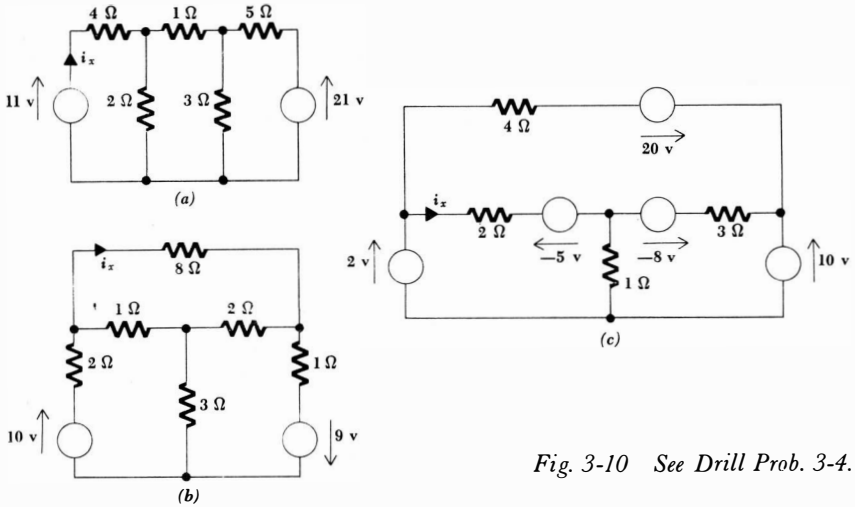

Fig. 3-10 See Drill Prob. 3-4.

Drill Problems

3-3 Evaluate the determinants:

(a)
$$\begin{vmatrix} 1 & 2 & 3 \\ 4 & 5 & 6 \\ 7 & 8 & 9 \end{vmatrix}$$

(b)
$$\begin{vmatrix} 1 & 0 & 0 & 0 \\ 0 & 10 & -5 & -1 \\ 0 & -5 & 6 & -1 \\ 0 & -1 & -1 & 2 \end{vmatrix}$$

(c)
$$\begin{vmatrix} 1 & 0 & -1 & 0 & 0 \\ 0 & 2 & 0 & 0 & 0 \\ -1 & 0 & 3 & 0 & 0 \\ 0 & 0 & 0 & 4 & 0 \\ 0 & 0 & 0 & 0 & 5 \end{vmatrix}$$

Ans. 44; 0; 80

3-4 Use mesh analysis to obtain a set of three equations and then use determinants to find i_x in the circuits shown in Fig. 3-10a, b, and c.

Ans. 0.909 amp; 1 amp; 1.5 amp

3-4 NODAL ANALYSIS

In the previous two sections we have become acquainted with the method of solving circuit problems by mesh analysis. One restriction was pointed out, the necessity of having a planar network. Loop analysis, discussed in Chap. 18, is more general than mesh analysis and does not have this restriction. A second

restriction, which is only temporary, is that all the sources must be voltage sources. Since we shall see in the next section that current and voltage sources may be easily interchanged, this limitation need not concern us.

Now we shall consider the method of nodal analysis, which is very closely the dual of mesh analysis. It should come as no surprise, then, that we shall first apply it to circuits which contain only current sources. This again is a temporary restriction. Nodal analysis, however, is more powerful than mesh analysis in one aspect: it applies equally well to both planar and nonplanar networks.

In mesh analysis we assumed M mesh currents in an M -mesh circuit, applied Kirchhoff's voltage law around each of the M meshes, and then solved the resulting M equations for the M unknown mesh currents by determinants or any other convenient method. Any other current or voltage in the circuit could then be quickly obtained by a simple use of Ohm's law or Kirchhoff's laws. In nodal analysis we shall focus our attention on the nodes in the circuit, and our unknowns will be the voltages existing between each node and a reference node. Thus, in a circuit possessing N nodes, we shall identify one node as a reference node, assign a voltage between each of the remaining $(N - 1)$ nodes and the reference node, and apply Kirchhoff's current law to each nonreference node. The $(N - 1)$ equations which result may again be solved by determinants for the $(N - 1)$ node-to-reference voltages. Other voltages and currents are then readily obtained if desired.

Let us illustrate the method of nodal analysis with a simple example. Consider the circuit shown in Fig. 3-11*a*. There are only three nodes in this circuit, and we may emphasize their locations by redrawing the circuit, as shown in Fig. 3-11*b*, in which each node is identified by a number. We would now like to associate a voltage with each node, but we must remember that a voltage must be defined as existing between *two* points in a network. We thus select one node as a reference node, and then define a voltage between each remaining node and the reference node. Hence, there will be only $(N - 1)$ voltages defined in an N -node circuit.

We choose node 3 as the reference node. Either of the other nodes could have been selected, but a little simplification in the resultant equations is obtained if the node to which the greatest number of branches is connected is identified as the reference node. In some practical circuits there may be a large number of elements connected to a metallic case or chassis on which the circuit is built; the chassis is often connected through a good conductor to the earth. Thus, the metallic case may be called "ground," and this ground node becomes the most convenient reference node. More often than not, it appears as a common lead across the bottom of a circuit diagram.

The voltage between node 1 and the reference node 3 is identified as e_1 , and e_2 is defined between node 2 and the reference. These two voltages are sufficient, and the voltage between any other pair of nodes may be found in terms of them. For example, the voltage of node 1 with respect to node 2 is $(e_1 - e_2)$. These three voltages and their sense arrows are shown in Fig. 3-11*c*. In this figure the resistance values have also been replaced with conductance values.

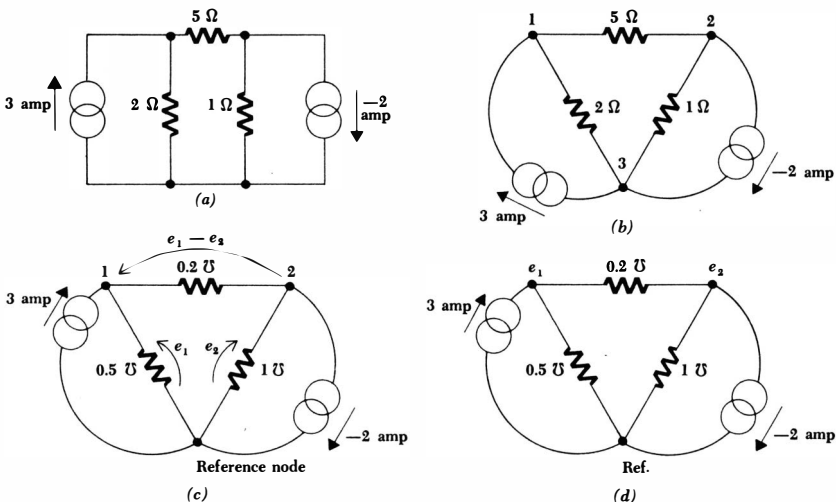

Fig. 3-11 (a) A given three-node circuit. (b) The circuit is redrawn to emphasize the three nodes and each node is numbered. (c) A voltage, including sense arrow, is assigned between each pair of nodes. (d) The voltage assignment is simplified by eliminating the sense arrows; it is understood that an arrow extends from the reference node to every other node. Voltages between nonreference nodes are not indicated.

The circuit diagram is finally simplified in Fig. 3-11d by eliminating all voltage sense arrows. A reference node is plainly marked, and the voltages placed at each node are *understood* to be the voltage of that node with respect to the reference node.

We must now apply Kirchhoff's current law to nodes 1 and 2. We do this by equating the total current leaving the node through the several conductances to the total source current entering the node. Thus,

$$0.5e_1 + 0.2(e_1 - e_2) = 3$$

$$\text{or} \quad 0.7e_1 - 0.2e_2 = 3 \tag{3-6}$$

At node 2 we obtain

$$e_2 + 0.2(e_2 - e_1) = 2$$

$$\text{or} \quad -0.2e_1 + 1.2e_2 = 2 \tag{3-7}$$

Equations (3-6) and (3-7) make up a second-order system of linear algebraic equations with the two node voltages as unknowns. The constant coefficients are conductances, and we therefore define the conductance determinant,

$$\Delta_g = \begin{vmatrix} 0.7 & -0.2 \\ -0.2 & 1.2 \end{vmatrix} = 0.84 - 0.04 = 0.8$$

Hence, by Cramer's rule,

$$e_1 = \frac{\Delta_1}{\Delta_g} = \frac{\begin{vmatrix} 3 & -0.2 \\ 2 & 1.2 \end{vmatrix}}{0.8} = \frac{3.6 + 0.4}{0.8} = 5 \text{ volts}$$

and
$$e_2 = \frac{\Delta_2}{\Delta_g} = \frac{\begin{vmatrix} 0.7 & 3 \\ -0.2 & 2 \end{vmatrix}}{0.8} = 2.5 \text{ volts}$$

The voltage between nodes 1 and 2 is $(e_1 - e_2)$, or 2.5 volts. Since the voltage across every element is known, we may consider the analysis complete.

Now let us look carefully at Eq. (3-6) and try to interpret each of the coefficients and signs appearing in it,

$$0.7e_1 - 0.2e_2 = 3 \tag{3-6}$$

The coefficient of e_1 is, loosely speaking, the total conductance connected to node 1. A somewhat better statement describes it as the sum of the conductances of the several branches connected to node 1. Alternatively, we may state that the coefficient of e_1 is the total conductance between node 1 and the reference node if all the other nodes are considered to be connected to the reference node and all current sources are open-circuited. The coefficient of e_2 is negative in this equation applying to node 1 because the sense arrows for e_1 and e_2 both point away from the reference node. The coefficient 0.2 is the sum of the conductances of the several branches connecting nodes 1 and 2. Finally, the constant 3 is the total current *entering* node 1 from the current sources. Thus,

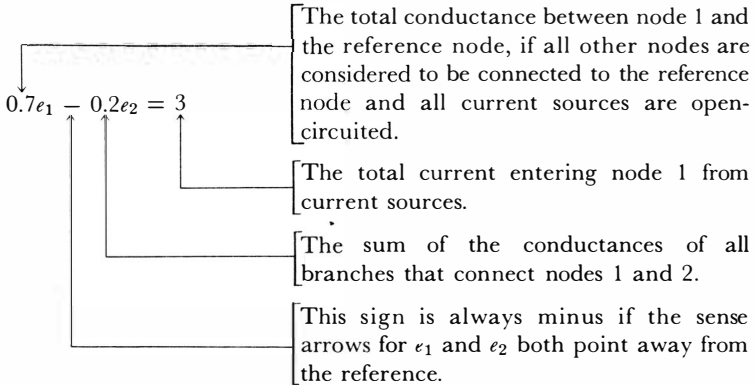

We might try now to write Eq. (3-7) by inspection, keeping the unknowns e_1 and e_2 in the same order as before. Since the sum of the conductances in the branches connecting nodes 1 and 2 is 0.2 mho, the coefficient of e_1 must be (-0.2) . Visualizing node 1 connected to the reference node and the current sources open-circuited, the conductance from node 2 to the reference is $(1 + 0.2)$, or 1.2 mhos. Hence, the coefficient of e_2 must be 1.2. Since the

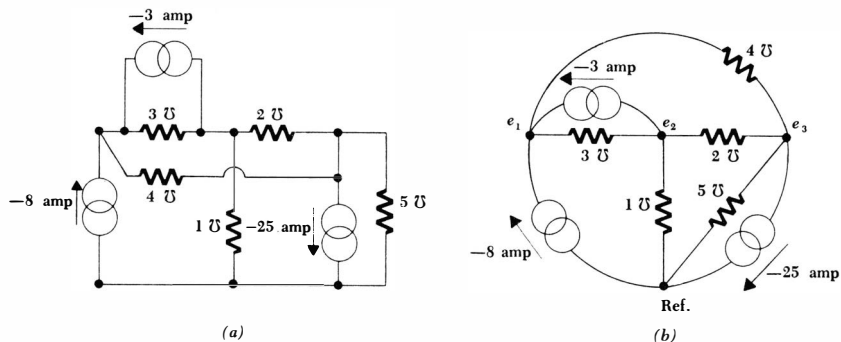

Fig. 3-12 (a) The given circuit. (b) The same circuit redrawn with node voltages assigned.

Hence,

$$e_1 = \frac{\begin{vmatrix} -11 & -3 & -4 \\ 3 & 6 & -2 \\ 25 & -2 & 11 \end{vmatrix}}{191} = \frac{191}{191} = 1 \text{ volt}$$

Similarly,

$$e_2 = 2 \text{ volts} \quad e_3 = 3 \text{ volts}$$

It is noteworthy that the same symmetry that appeared in the resistance determinant Δ_r in mesh-analysis problems also prevails in these nodal-analysis problems. That is, in Δ_g the negative terms are symmetrically located in pairs on either side of the principal diagonal. Also, all principal diagonal terms are positive.

Before concluding our discussion of nodal analysis, it may be helpful to point out a few things we do *not* know yet about nodal and mesh analysis. One decision that must always be made first is whether to use mesh analysis or nodal analysis. At the present time, this question is easily answered because the type of source present decides this for us. However, we shall shortly learn how to transform back and forth between current and voltage sources at will, and the decision will again confront us. The choice must be made then by considering the number of equations that will result from each method, and we should choose that method which produces fewer equations. If the circuit is non-planar, then nodal analysis must be used. A study of elementary network topology and the use of *loop* equations in Chap. 18 will allow us to make a more careful choice.

Occasionally, we are confronted with problems in which the sources and the element values are not all given. Perhaps we are given a current in one branch of a network and must determine a resistance value somewhere else. We should not then go blindly ahead and use determinants and mesh and nodal analysis; there may be a much easier method. For example, the three-

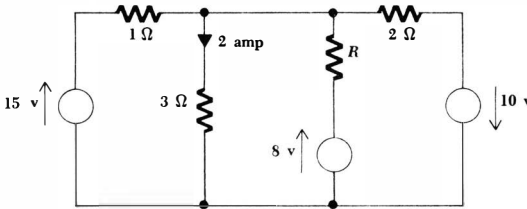

Fig. 3-13 A three-mesh circuit in which one of the resistance values is unknown but one current is specified. A series of simple steps shows that $R = 2$ ohms.

mesh circuit shown in Fig. 3-13 contains an unknown resistance R and has a known current in the 3-ohm resistor. Although mesh analysis and determinants might be used, the unknown resistance can be found by a sequence of very simple steps. The use of source transformations, Thévenin's theorem, and Norton's theorem also may offer a much simpler solution in many problems than a more formal use of mesh or nodal analysis.

Drill Problems

3-5 Use nodal analysis to determine e_x in each circuit of Fig. 3-14.

Ans. 11 volts; 9 volts; -1 volt

3-6 Find the power delivered by sources a , b , and c in the circuit of Fig. 3-15.

Ans. 18 watts; 54 watts; 162 watts

3-5 SOURCE TRANSFORMATIONS

In all our previous work we have been making continual use of *ideal* voltage and current sources; it is now time to take a step closer to reality by considering *practical* current and voltage sources. These sources will enable us to make more realistic representations of physical devices. Having defined the practical sources, we shall then study methods whereby practical current and voltage sources may be interchanged without affecting the remainder of the circuit. Such sources will be called *equivalent* sources. With the ability to transform current sources into voltage sources, and vice versa, mesh and nodal analysis both become applicable to any planar physical circuit.

The ideal voltage source was defined as a device whose terminal voltage is independent of the current through it. A one-volt d-c source produces a current of one ampere through a one-ohm resistor and a current of one million amperes through a one-microhm resistor; it may provide an unlimited amount of power. No such device exists practically, of course, and we agreed that a real physical source might be represented by an ideal source only as long as relatively small currents, or powers, were drawn from it. For example, an automobile storage battery may be approximated by an ideal d-c voltage source if its current is limited to a few amperes. However, anyone who has ever tried to start an automobile with the headlights on must have observed that the lights dimmed

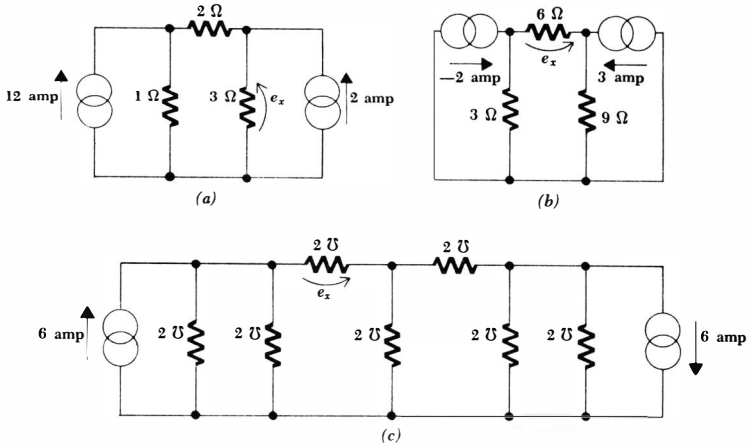

Fig. 3-14 See Drill Probs. 3-5 and 3-8.

perceptibly when the battery was asked to deliver the heavy starter current, 100 amp or more, in addition to the headlight current. Under these conditions, an ideal voltage source may be a very poor representation of the storage battery.

The ideal voltage source must be modified to account for the lowering of its terminal voltage when large currents are drawn from it. Let us suppose that we observe experimentally that a storage battery has a terminal voltage of 12 volts when no current is flowing through it and a reduced voltage of 11 volts when 100 amp is flowing. Thus, a more accurate representation might be an ideal voltage source of 12 volts in series with a resistor across which 1 volt appears when 100 amp flows through it. The resistor must be 0.01 ohm, and the ideal voltage source and this series resistance comprise a *practical voltage source*. This particular practical voltage source is shown connected to a general

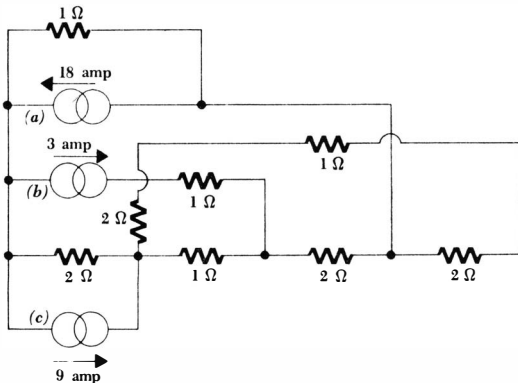

Fig. 3-15 See Drill Prob. 3-6.

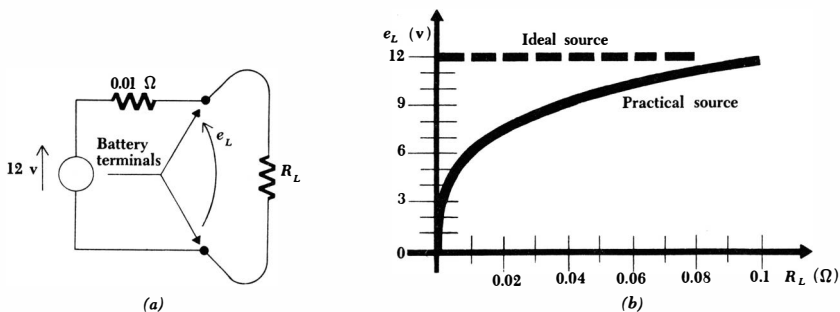

Fig. 3-16 (a) A practical source is shown which approximates the behavior of a certain 12-volt storage battery. (b) A plot of terminal voltage versus load resistance.

load resistor R_L in Fig. 3-16a; the terminal voltage of the practical source is the same as the voltage across R_L and is marked e_L . In Fig. 3-16b a plot of the terminal voltage as a function of the load resistance points out the fact that the output voltage approaches that of the ideal source only for large values of the load resistance where relatively small currents are drawn. The terminal voltage is only one-half the voltage of the ideal source when the load resistance is equal to the internal resistance of the practical source.

Let us now consider a general practical voltage source, as shown in Fig. 3-17. The voltage of the ideal source is e_s , and a resistance R_{se} , called an *internal resistance*, is placed in series with it. The resistor is not one which we would wire or solder into a circuit, but merely serves to account for a terminal voltage which decreases as the load current increases, and thus its presence enables us to represent a physical voltage source more closely. The voltage e_L across the load resistor R_L is thus

$$e_L = \frac{R_L}{R_{se} + R_L} e_s \quad (3-8)$$

and the load current i_L is

$$i_L = \frac{e_s}{R_{se} + R_L} \quad (3-9)$$

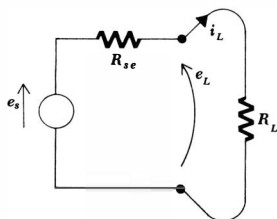

Fig. 3-17 A general practical voltage source.

An ideal current source is also nonexistent in the real world; there is no physical device which will deliver a constant current, regardless of the load resistance to which it is connected or the voltage across its terminals. A pentode vacuum-tube amplifier and certain transistor circuits will deliver a constant current to a wide range of load resistances, but the load resistance can always be made sufficiently large that the current through it becomes very small. Infinite power is simply never available.

A practical current source is defined as an ideal current source in parallel with an internal resistance R_{si} . Such a source is shown in Fig. 3-18*a*, and the current i_L and voltage e_L produced across a load resistor R_L are indicated. It is apparent that

$$i_L = \frac{R_{si}}{R_{si} + R_L} i_s \quad (3-10)$$

and
$$e_L = \frac{R_{si}R_L}{R_{si} + R_L} i_s \quad (3-11)$$

The variation of load current with changing load resistance is shown in Fig. 3-18*b*, and it is evident that the load current and ideal source current are approximately equal only for values of load resistance which are small compared with R_{si} .

We are now ready to discuss the equivalence of practical voltage and current sources. We shall define two sources as being *equivalent* if each produces identical current and identical voltage in *any* load resistance which is placed across its terminals. In other words, if we are confronted with two black boxes, each having a single pair of terminals on it, then there is no way in which we can differentiate between the boxes by measuring current or voltage in a resistive load.

It should be noted carefully that although equivalent sources will deliver the same current, voltage, and power to identical resistive loads, the power which the two *ideal* sources supply and the power absorbed in R_{se} and R_{si} may be quite different.

Fig. 3-18 (a) A general practical current source. (b) The load current provided by the practical current source is shown as a function of the load resistance.

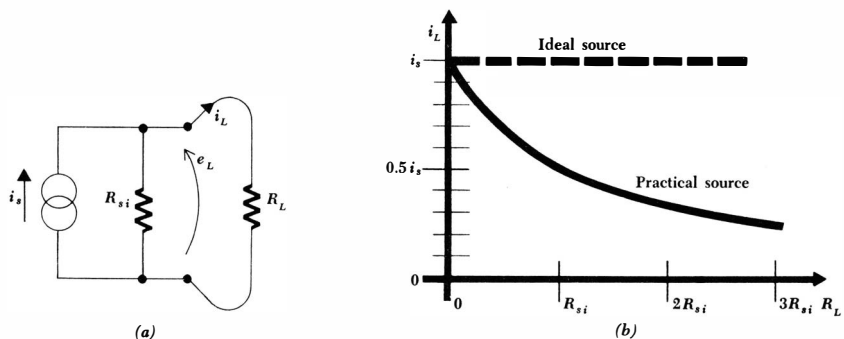
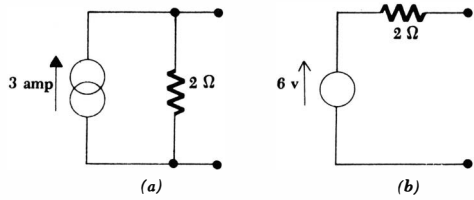

Fig. 3-19 (a) A given practical current source. (b) The equivalent practical voltage source.



The conditions for equivalence are now quickly established. Since the load currents are to be identical, from Eqs. (3-9) and (3-10) we have

$$i_L = \frac{e_s}{R_{se} + R_L} = \frac{R_{si}i_s}{R_{si} + R_L}$$

and if these two expressions are to be the same for any R_L , then it follows that

$$R_{se} = R_{si} = R_s \tag{3-12}$$

and $e_s = i_s R_s$ (3-13)

where we shall now let R_s represent the internal resistance of either practical source. It is easily shown that these same two conditions may be obtained from Eqs. (3-8) and (3-11).

As an example of the use of these ideas, consider the practical current source shown in Fig. 3-19a. Since its internal resistance is 2 ohms, the internal resistance of the equivalent practical voltage source is also 2 ohms; the voltage of the ideal voltage source contained within the practical voltage source is $(2)(3) = 6$ volts. The equivalent practical voltage source is shown in Fig. 3-19b.

To check the equivalence, let us visualize a 4-ohm resistor connected to each source. In both cases, a current of 1 amp, a voltage of 4 volts, and a power of 4 watts are associated with the 4-ohm load. However, the ideal current source is delivering a total power of 12 watts, while the ideal voltage source is delivering only 6 watts. Correspondingly different powers are dissipated in the two internal resistances.

It is enlightening to develop the equivalence conditions by a slightly different method. Suppose that we are given a practical current source and are asked to determine the equivalent voltage source. There are two unknowns e_s and R_{se} . We therefore need two facts, or equations, and we may easily obtain these by forcing the current that each source delivers to a short circuit and the voltage that each delivers to an open circuit to be identical. We first equate the two short-circuit currents

$$i_{Lsc} = i_s = \frac{e_s}{R_{se}}$$

and, hence,

$$e_s = i_s R_{se}$$

77 **Some Useful Techniques of Circuit Analysis**

and then the two open-circuit voltages

$$e_{Loc} = e_s = i_s R_{si} \quad \text{or} \quad e_s = i_s R_{si}$$

Finally,

$$R_{se} = R_{si} = R_s \quad \text{and} \quad e_s = i_s R_s$$

as before.

Drill Problems

3-7 Each ideal voltage source in the three circuits of Fig. 3-7 is in series with a resistance which may be interpreted as an internal resistance. Transform each practical voltage source into an equivalent practical current source, and then write and solve the single nodal equation necessary. Determine i_x .

Ans. 1.375 amp; -3 amp; 2.4 amp

3-8 Identify the practical current sources in the circuits of Fig. 3-14 and transform each to an equivalent voltage source. Solve by mesh methods and find e_x .

Ans. 11 volts; 9 volts; -1 volt

3-9 Find e_x in each circuit of Fig. 3-20.

Ans. 45 volts; 60 volts; 12 volts

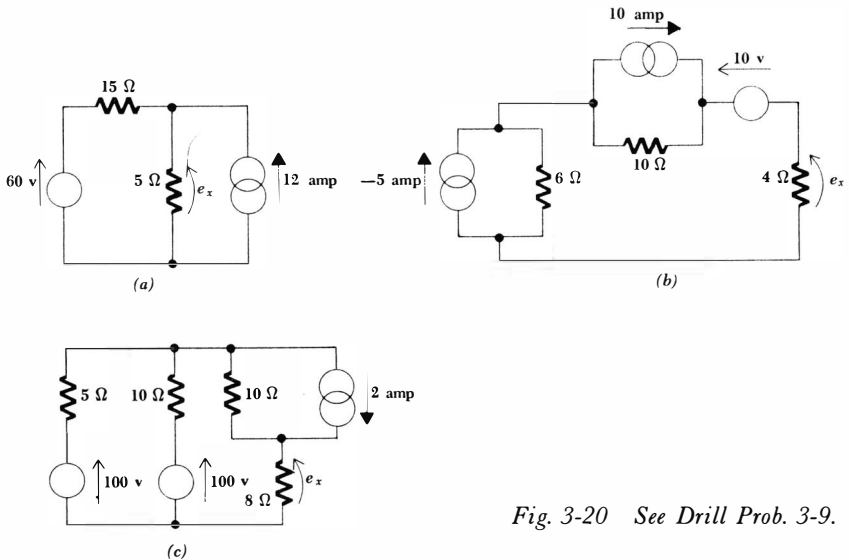

Fig. 3-20 See Drill Prob. 3-9.

If we replace the sources $i_{s1}, i_{s2}, \dots, i_{sN}$ by $Ki_{s1}, Ki_{s2}, \dots, Ki_{sN}$, then it is evident that the solution of this new set of equations will be the node voltages Ke_1, Ke_2, \dots, Ke_N ; every response is larger by a factor of K . A similar argument may be applied if a general system of mesh equations is used to describe the circuit.

The most important consequence of linearity is superposition. Let us prove the superposition principle by considering first the circuit of Fig. 3-21, which contains two energy sources, the current generators which force the currents i_a and i_b into the circuit. Sources are often called *forcing functions* for this reason, and the voltages which they produce between node 1 or 2 and the reference node may be termed *response functions*, or simply *responses*. Both the forcing functions and the responses may be functions of time.

The two nodal equations for this circuit are

$$0.7e_1 - 0.2e_2 = i_a \quad (3-14)$$

$$-0.2e_1 + 1.2e_2 = i_b \quad (3-15)$$

Now let us perform experiment x . We change the two forcing functions to i_{ax} and i_{bx} ; the two unknown voltages will now be different, and we shall let them be e_{1x} and e_{2x} . Thus,

$$0.7e_{1x} - 0.2e_{2x} = i_{ax} \quad (3-16)$$

$$-0.2e_{1x} + 1.2e_{2x} = i_{bx} \quad (3-17)$$

We next perform experiment y by changing the source currents to i_{ay} and i_{by} and by letting the responses be e_{1y} and e_{2y} ,

$$0.7e_{1y} - 0.2e_{2y} = i_{ay} \quad (3-18)$$

$$-0.2e_{1y} + 1.2e_{2y} = i_{by} \quad (3-19)$$

These three sets of equations describe the same circuit with different source currents. Let us *add* or *superpose* the last two sets of equations. Adding Eq. (3-16) to Eq. (3-18),

$$(0.7e_{1x} + 0.7e_{1y}) - (0.2e_{2x} + 0.2e_{2y}) = i_{ax} + i_{ay} \quad (3-20)$$

$$0.7e_1 - 0.2e_2 = i_a \quad (3-14)$$

and adding Eq. (3-17) to Eq. (3-19),

$$-(0.2e_{1x} + 0.2e_{1y}) + (1.2e_{2x} + 1.2e_{2y}) = i_{bx} + i_{by} \quad (3-21)$$

$$-0.2e_1 + 1.2e_2 = i_b \quad (3-15)$$

Fig. 3-21 A three-node circuit containing two forcing functions which is used to illustrate the superposition principle.

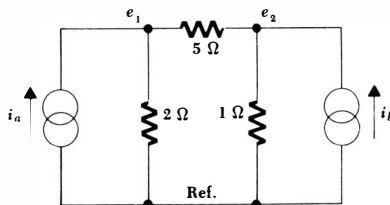

where Eq. (3-14) has been written immediately below Eq. (3-20), and Eq. (3-15) below Eq. (3-21) for easy comparison.

The linearity of all these equations allows us to compare Eq. (3-20) with Eq. (3-14) and Eq. (3-21) with Eq. (3-15) and draw an interesting conclusion. If we select i_{ax} and i_{ay} such that their sum is i_a , select i_{bx} and i_{by} such that their sum is i_b , then the desired responses e_1 and e_2 may be found by adding e_{1x} to e_{1y} and e_{2x} to e_{2y} , respectively. In other words, we may perform experiment x and note the responses, perform experiment y and note the responses, and finally add the corresponding responses. These are the responses of the original circuit to sources which are the sums of the sources used in experiments x and y . This is the fundamental concept involved in the superposition principle.

It is evident that we may extend these results by breaking up either source current into as many pieces as we wish; there is no reason why we cannot perform experiments z and q also. It is only necessary that the algebraic sum of the pieces be equal to the original current. It should also be evident that superposition is applicable to any resistive circuit which can be described by the set of N linear algebraic equations appearing on page 78. Superposition is also applicable to circuits containing ideal voltage sources, as may be shown by writing a set of mesh equations.

The *superposition theorem* usually appears in a form similar to the following:

In any linear resistive network containing several sources, the voltage across or the current through any resistor or source may be calculated by adding algebraically all the individual voltages or currents caused by each source acting alone, with all other voltage sources replaced by short circuits and all other current sources replaced by open circuits.

Thus if there are N sources, we perform N experiments. Each source is active in only one experiment, and only one source is active in each experiment. An inactive voltage source is identical with a short circuit, and an inactive current source is an open circuit.

Our proof of superposition, however, should indicate that a much stronger theorem might be written; a group of sources may be made active and inactive collectively, if we wish. For example, suppose there are three sources. The theorem above states that we may find a given response by considering each of the three sources acting alone and adding the three results. Alternatively, we may find the response due to the first and second sources operating with the third inactive, and then add to this the response caused by the third source acting alone. This amounts to treating several sources collectively as a sort of supersource.

There is also no reason that a source must assume only its given value or a zero value in the several experiments; it is only necessary for the sum of the several values to be equal to the original value. An inactive source almost always leads to the simplest circuit, however.

Let us illustrate the application of the superposition principle by considering an example in which both types of source are present. It is not necessary to transform either source. For the circuit of Fig. 3-22, let us use superposition to

Fig. 3-22 A circuit containing both a current and voltage source which is used as an example of superposition.

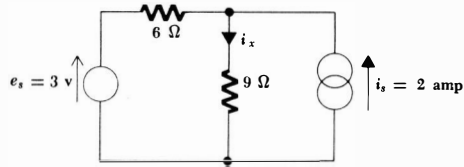

write an expression for the unknown branch current i_x . We may first kill the current source and obtain the portion of i_x due to the voltage source as 0.2 amp. Then if we kill the voltage source and apply current division, the remaining portion of i_x is seen to be 0.8 amp. We might write the answer in detail as

$$i_x = i_x \Big|_{i_s=0} + i_x \Big|_{e_s=0} = \frac{3}{6+9} + 2 \frac{6}{6+9} = 0.2 + 0.8 = 1.0 \text{ amp}$$

We must constantly be aware of the limitations of superposition. It is applicable only to linear responses, and thus the most common nonlinear response, power, is not subject to superposition. For example, consider two 1-volt batteries in series with a 1-ohm resistance. The power delivered to the resistor is obviously 4 watts, but if we mistakenly try to apply superposition we might say that each battery alone furnished 1 watt and thus the total power is 2 watts. This is incorrect.

Drill Problems

3-10 Use the superposition principle to find i_x in each of the circuits shown in Fig. 3-23a, b, and c.

Ans. - 3.33 amp; 3.64 amp; 5.03 amp

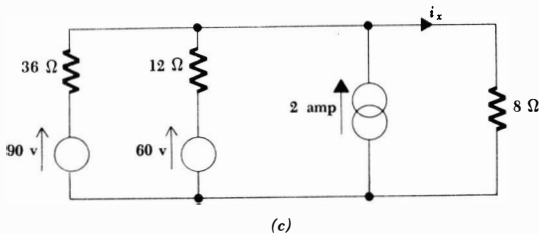
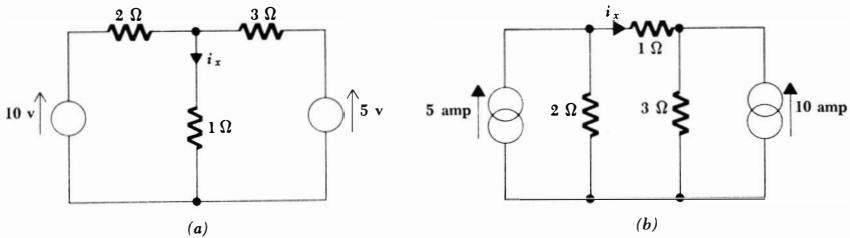

Fig. 3-23 See Drill Prob. 3-10.

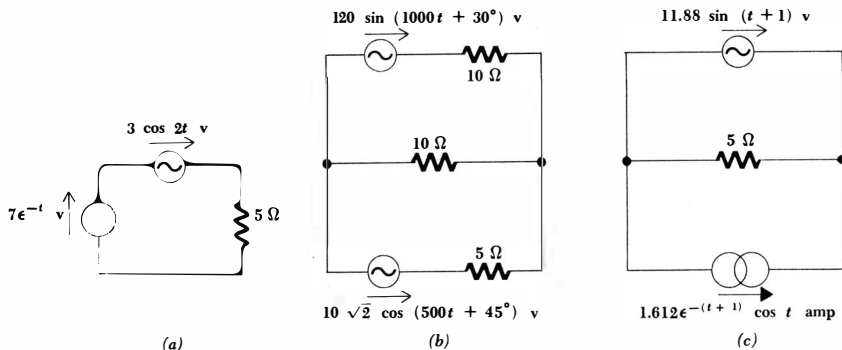

Fig. 3-24 See Drill Prob. 3-11.

3-11 In each circuit of Fig. 3-24a, b, and c show that the instantaneous power delivered to the 5-ohm resistor at $t = 0$ is 20 watts.

Ans. 20 watts; 20 watts; 20 watts

3-7 THÉVENIN'S AND NORTON'S THEOREMS

Now that we have proved the superposition principle, it becomes possible to prove two more theorems which will greatly simplify the analysis of many linear circuits. The first of these theorems is named after M. L. Thévenin, a French engineer working in telegraphy, who first published a statement of the theorem in 1883; the second may be considered a corollary of the first and is credited to E. L. Norton, a scientist with the Bell Telephone Laboratories.

Let us suppose that we need to make only a partial analysis of a circuit; perhaps we wish to determine the current, voltage, and power delivered to a single load resistor by the remainder of the circuit, which may consist of any number of sources and resistances. Thévenin's theorem then tells us that it is possible to replace everything except the load resistor by an equivalent circuit containing only an ideal voltage source in series with a resistor; the response measured at the load resistor will be unchanged. Using Norton's theorem, we should obtain an equivalent composed of an ideal current source in parallel with a resistor.

It should thus be apparent that one of the main uses of Thévenin's and Norton's theorems is the replacement of a large part of a network, often a complicated and uninteresting part, by a very simple equivalent. The new, simpler circuit enables us to make rapid calculations of the voltage, current, and power which the original circuit is able to deliver to a load. It also helps us to choose the best value of this load resistance. In a vacuum-tube amplifier, for example, the Thévenin or Norton equivalent enables us to determine the maximum power that can be taken from the amplifier and the type of load that is required to accomplish a maximum transfer of power or to obtain maximum practical voltage or current amplification.

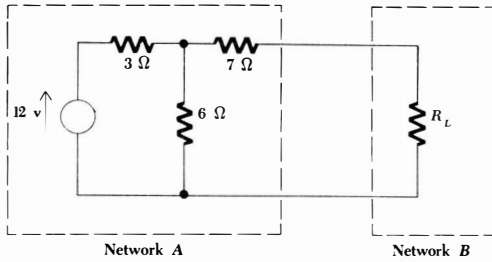
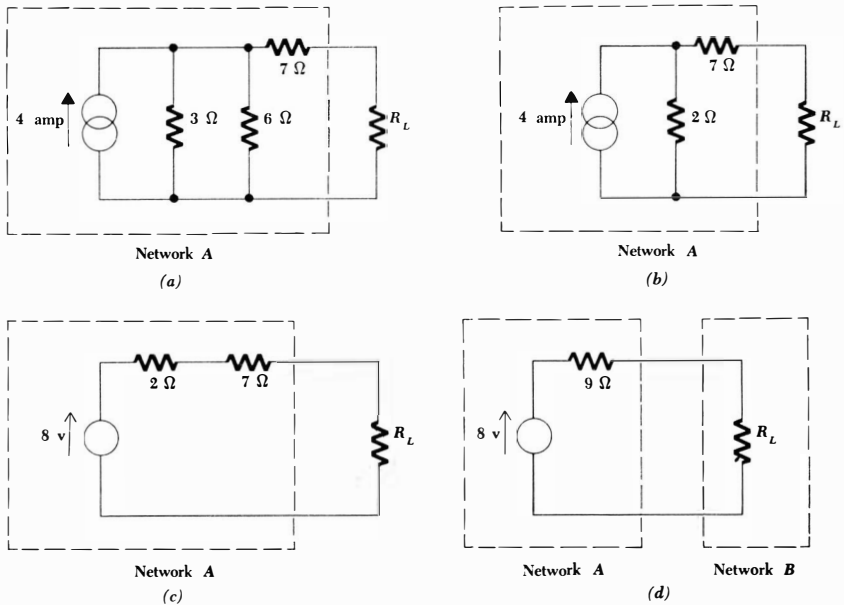

Fig. 3-25 A simple resistive circuit is divided into network A, in which we have no detailed interest, and network B, a load resistor with which we are fascinated.

Consider the circuit shown in Fig. 3-25. The broken lines separate the circuit into networks A and B; we shall assume that our main interest is in network B, which consists only of the load resistor R_L . Network A may be simplified by making repeated source transformations. We first treat the 12-volt source and the 3-ohm resistor as a practical voltage source and replace it with a practical current source consisting of an ideal 4-amp source in parallel with 3 ohms. The parallel resistances are then combined into 2 ohms, and the practical current source which results is transformed back into a practical voltage source. The steps are indicated in Fig. 3-26, the final result appearing in Fig. 3-26d.

Fig. 3-26 The source transformations and resistance combinations involved in simplifying network A are shown in order. The result, shown in (d), is the Thévenin equivalent.



From the viewpoint of the load resistor R_L , this circuit (the Thévenin equivalent) is equivalent to the original circuit; from our viewpoint, the circuit is much simpler and we can now easily compute the power delivered to the load. It is

$$p_L = \left(\frac{8}{9 + R_L} \right)^2 R_L$$

Furthermore we can see from the equivalent circuit that the maximum voltage which can be obtained across R_L is 8 volts; a quick transformation of network A to a practical current source (the Norton equivalent) indicates that the maximum current which may be delivered to the load is $\frac{8}{9}$ amp; and a review of the results of Chap. 2, Prob. 16, shows that a maximum power is delivered to R_L when R_L is 9 ohms. None of these facts is apparent from the original circuit.

If network A had been more complicated, the number of source transformations and resistance combinations necessary to obtain the Thévenin or Norton equivalent could easily become prohibitive. Thévenin's and Norton's theorems allow us to find the equivalent circuit much more quickly and easily, even in more complicated circuits.

Let us now state *Thévenin's theorem* formally and then consider the problem of proving it. The theorem is:

Given any linear active circuit, rearrange it in the form of two networks A and B that are connected together by two resistanceless conductors. Define a voltage e_{oc} as the open-circuit voltage which would appear across the terminals of A if B were disconnected so that no current is drawn from A . Then all the currents and voltages in B will remain unchanged if A is killed (all voltage sources and current sources in A replaced by short circuits and open circuits, respectively) and an ideal voltage source e_{oc} is connected, with proper polarity, in series with the dead (inactive) A network.

Figure 3-27 affords a brief pictorial outline of the steps of the theorem stated above. Note how the polarity of e_{oc} is chosen to give the correct polarity in the equivalent circuit; the open-circuit voltage of Fig. 3-27*b* must be the same as that of Fig. 3-27*c*.

Before presenting the proof of Thevenin's theorem, let us see if we can apply it successfully to the circuit we considered in Fig. 3-25. Disconnecting R_L , voltage division enables us to determine that e_{oc} is 8 volts. Killing the A network, that is, replacing the 12-volt source by a short circuit, we see looking back into the dead A network a 7-ohm resistor connected in series with the parallel combination of 6 ohms and 3 ohms. Thus the dead A network can be represented here by simply a 9-ohm resistor. This agrees with the previous result.

The equivalent circuit we have obtained is completely independent of the B network, because we have been instructed first to remove the B network and measure the open-circuit voltage produced by the A network, an operation which certainly does not depend on the B network in any way, and then to place the inactive A network in series with a voltage source e_{oc} . The B network is mentioned in the theorem and proof only to indicate that an

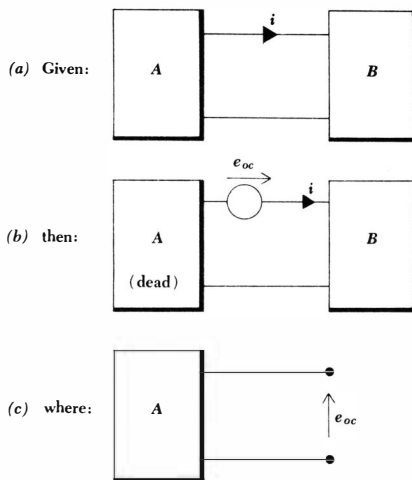

Fig. 3-27 A pictorial outline of the steps which comprise Thévenin's theorem.

equivalent for A may be obtained *no matter what arrangement of elements is connected to the A network*; the B network represents this general network.

Now let us devote several pages to proving the theorem in its general form. We shall do so by showing that the original A network and the Thévenin equivalent of the A network both cause the same current to flow into the terminals of the B network. If the currents are the same, then the voltages must be the same; in other words, if we apply a certain current, which we might think of as a current source, to the B network, then the current source and the B network constitute a circuit which has a specific input voltage as a response. Thus, the current determines the voltage. Alternatively we could, if we wished, show that the terminal voltage at B is unchanged, because the voltage also determines the current uniquely. If the input voltage and current to the B network are unchanged, then it follows that the currents and voltages *throughout* the B network are also unchanged.

Let us first prove the theorem for the case where the B network is inactive. After this step has been accomplished, we may then use the superposition principle to extend the theorem to include B networks which contain sources.

The current i , flowing in the upper conductor from the A network to the B network, is therefore caused entirely by the sources present in the A network. Suppose now that we add an additional voltage source e_x , which we shall call the Thévenin source, in the conductor in which i is measured, as shown in Fig. 3-28a, and then adjust the magnitude and time variation of e_x until the current is reduced to zero. By our definition of e_{oc} , then, the voltage across the terminals of A must be e_{oc} since no current is flowing. The B network is dead, and no current is entering its terminals; therefore, there is no voltage across the terminals of the B network, and by Kirchhoff's voltage law the voltage of the Thévenin source is e_{oc} volts, $e_x = e_{oc}$. Moreover, since the Thévenin source and

the A network jointly deliver no current to B , and since the A network by itself delivers a current i , then superposition requires that the Thévenin source acting by itself deliver $-i$ amp to B . The source acting alone in a reversed direction, as shown in Fig. 3-28*b*, therefore produces a current in the upper lead i . This situation, however, is the same as the conclusion reached by Thévenin's theorem: the Thévenin source e_{oc} acting in series with the inactive A network is equivalent to the given network.

Now let us consider the case where the B network may be an active network. We now think of the current i , flowing from the A network to the B network in the upper conductor, as being composed of two parts i_A and i_B , where i_A is the current produced by A acting alone and the current i_B is due to B acting alone. Our ability to divide the current into these two components is a direct consequence of the applicability of the superposition principle to these two linear networks; the complete response and the two partial responses are indicated by the diagrams of Fig. 3-29.

The partial response i_A has already been considered; if network B is inactive, we know that network A may be replaced by the Thévenin source and the inactive A network. In other words, of the three sources which we must keep in mind, those in A , those in B , and the Thévenin source, the partial response i_A occurs when A and B are dead and the Thévenin source is active. Preparing for the use of superposition, we now let A remain inactive, but turn on B and turn off the Thévenin source; by definition, the partial response i_B is obtained. Superimposing the results, the response when A is dead and both the Thévenin source and B are active is $i_A + i_B$. This sum is the original current i , and the situation wherein the Thévenin source and B are active, but A is dead, is the desired Thévenin equivalent circuit. Thus the active network A may be replaced by its Thévenin source, the open-circuit voltage, in series with the inactive A network, regardless of the status of the B network; it may be either active or inactive.

There are several points about the foregoing proof which deserve emphasis. First, we should note that it has not been necessary to impose any restrictions

Fig. 3-28 (a) The Thévenin source is inserted in the circuit with B inactive and adjusted until no current flows. No voltage appears across network B and thus $e_x = e_{oc}$. The Thévenin source thus produces $-i$ amp while network A provides i amp. (b) The Thévenin source is reversed and network A is killed. The current is therefore i .

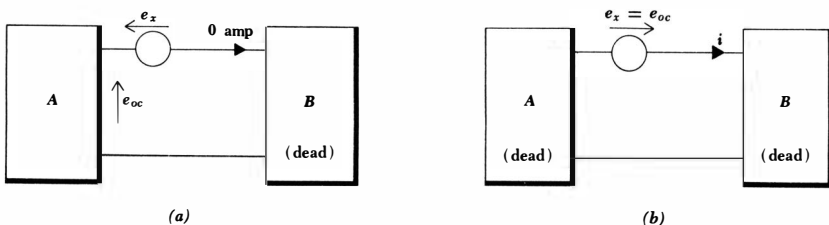

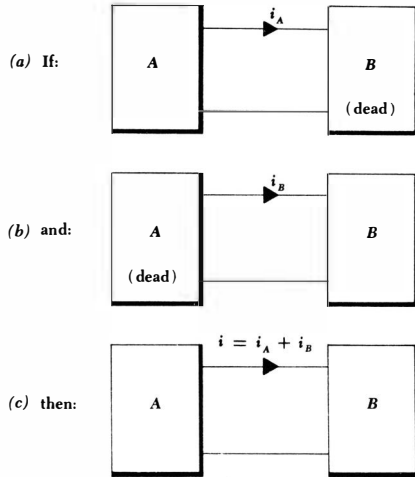

Fig. 3-29 Superposition enables the current i to be considered as the sum of two partial responses.

on A or B , other than requiring that the original circuit composed of A and B be a linear circuit. No restrictions were imposed on the complexity of A or B ; either one may contain any combination of voltage sources, current sources, resistors, or any other circuit elements which are linear. The general nature of the theorem and proof will enable it to be applied to networks containing inductors and capacitors, which are linear passive circuit elements to be defined in the following chapter. At this time, however, resistors are the only passive circuit elements which have been defined, and the application of Thévenin's theorem to resistive networks is a particularly simple special case. The dead A network can be represented by a single equivalent resistance, R_{th} .

Until the other passive circuit elements are introduced, then, we may utilize the simpler version of Thévenin's theorem outlined in Fig. 3-30; network A is replaced by an equivalent circuit composed of the Thévenin source and the Thévenin resistance.

It still remains to state and prove Norton's theorem. This theorem bears a close resemblance to Thévenin's theorem, the resemblance being another consequence of duality; as a matter of fact, the two statements will be used as an example of dual language when the duality principle is discussed in Chap. 4.

Norton's theorem may be stated as follows:

Given any linear active circuit, rearrange it in the form of two networks A and B that are connected together by two resistanceless conductors. Define a current i_{sc} as the short-circuit current which would appear at the terminals of A if B were short-circuited so that no voltage is provided by A . Then all the voltages and currents in B will remain unchanged if A is killed (all current sources and voltage sources in A replaced by open circuits and short circuits, respectively) and an ideal current source i_{sc} is connected, with proper polarity, in parallel with the dead (inactive) A network.

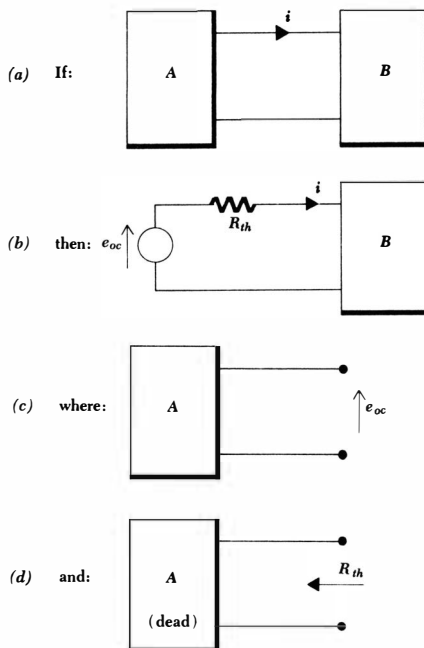

Fig. 3-30 A pictorial statement of Thévenin's theorem for the special case in which network A is an active resistive network.

Let us first consider the special case in which the B network is inactive. Our given circuit is therefore of the form shown in Fig. 3-31a. We now add a current source i_x , which we shall term the Norton source, between the two connecting leads, as shown in Fig. 3-31b, and adjust its amplitude and time variation until the current flowing into B is reduced to zero. This zero current requires that the voltage across the B network be zero; thus, the voltage across the terminals of the A network must also be zero, and the current drawn from the A network must be the short-circuit current i_{sc} . Hence, $i_x = -i_{sc}$. The proof for this special case is concluded by realizing that if A alone provides i amp, then the Norton source alone provides $-i$ amp and a reversal of the Norton source, as shown in Fig. 3-31c, must produce i amp. Thus this circuit and the original circuit are equivalent.

If B is an active network, then an additional application of the superposition principle is needed. The given circuit is now considered to produce the response i as the sum of the two components i_A and i_B . The first, i_A , is produced when A is dead and when the Norton source is on and B is off. The remaining portion, i_B , is provided also for the case of A dead, but with the Norton source off and B on. Superposition thus shows that $i_A + i_B$, or i , is the response if A is dead but both the Norton source and B are active. This is the desired conclusion and completes the outline of the proof of Norton's theorem. The proof has been sketchy, but this provides an excellent opportunity to draw a few

additional diagrams and to provide a few additional phrases in order to test our understanding of the principles involved in the proof.

If A is an active resistive network, then it is obvious that the inactive A network may be replaced by a single equivalent resistance, which we shall also call the Thévenin resistance, since it is once again the resistance viewed at the terminals of the inactive A network. The Norton equivalent of an active resistive network is therefore the Norton current source i_{sc} in parallel with the Thévenin resistance R_{th} . This special case, which is sufficient for our present purposes since no other passive elements have as yet been defined, is outlined in Fig. 3-32.

There is an important relationship between the Thévenin and Norton equivalents of an active resistive network. The relationship may be obtained by applying a source transformation to either equivalent network. For example, if we transform the Norton equivalent, we obtain a voltage source $i_{sc}R_{th}$ in series with the resistance R_{th} ; this network is in the form of the Thévenin equivalent, and thus

$$e_{oc} = i_{sc}R_{th} \tag{3-22}$$

In resistive circuits containing *dependent* sources, we shall often find it more convenient to determine either the Thévenin or Norton equivalent by finding both the open-circuit voltage and the short-circuit current and then determining the value of R_{th} as their quotient. It is therefore advisable to become adept at finding both open-circuit voltages and short-circuit currents, even in the simple problems which follow. If the Thévenin and Norton equivalents are determined independently, Eq. (3-22) may serve as a useful check.

Fig. 3-31 (a) The given circuit to which Norton's theorem is to be applied; the special case is considered in which B is inactive. (b) The Norton source is inserted in the circuit and adjusted until no current flows. No voltage appears across network A or B and thus $i_x = -i_{sc}$. The Norton source thus produces $-i$ amp while network A provides i amp. (c) The Norton source is reversed and network A is killed. The current is therefore i .

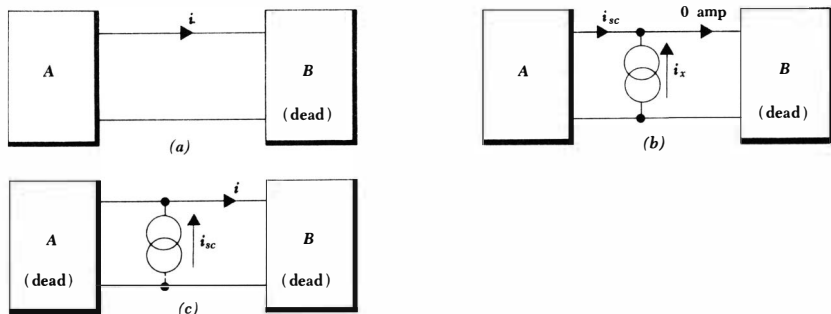

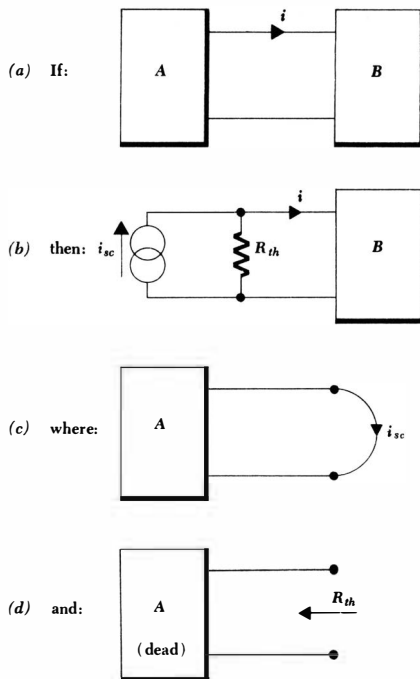

Fig. 3-32 A pictorial statement of Norton's theorem for the special case in which network *A* is an active resistive network.

For the circuit of Fig. 3-25, the current flowing downward through a short circuit across the terminals of network *A* is

$$i_{sc} = \frac{12}{3 + 4\frac{2}{13}} \frac{6}{13} = \frac{6}{13} \text{ amp}$$

and the Norton equivalent of *A* is therefore an ideal $\frac{6}{13}$ -amp current source in parallel with 9 ohms.

Although we are devoting our attention almost entirely to the analysis of *linear* circuits, it is enlightening to know that Thévenin's and Norton's theorems are both valid if network *B* is nonlinear; only network *A* must be linear.

Drill Problems

3-12 Find the open-circuit voltage and Thévenin resistance of each of the two-terminal networks shown in Fig. 3-33.

Ans. 30 volts, 0 ohms; 60 volts, 12 ohms; -20 volts, 3 ohms

3-13 Find the short-circuit current and Thévenin resistance of each of the two-terminal networks shown in Fig. 3-34.

Ans. 6 amp, 8 ohms; -1.5 amp, 40 ohms; 16 amp, 5.62 ohms

91 *Some Useful Techniques of Circuit Analysis*

3-14 In each circuit of Fig. 3-35, find the value of R_L which will absorb a maximum power, and determine this maximum power.

Ans. 2.4 ohms, 72.6 watts; 25 ohms, 81 watts; 10 ohms, 90 watts

Problems

- ◆1 Redraw the circuits shown in Fig. 3-36 as planar circuits and determine the number of meshes in each.
- 2 Redraw the circuit of Fig. 3-4 in such a way that the 3-ohm branch is on the right and the 4-ohm 10-volt arm is in the center. Solve by mesh analysis and compare with the solution of the original circuit.
- ◆3 In the circuit of Fig. 3-37a, the left voltage source is delivering 24 watts. Find R_x .
- 4 Draw a possible circuit, showing all mesh currents, which will yield the following set of mesh equations:

(a) $10i_1 - 2i_2 = 18$	(b) $20i_1 - 4i_2 = 50$
$-2i_1 + 5i_2 = -6$	$-4i_1 + 25i_2 - 10i_3 = 0$
	$-10i_2 + 12i_3 = 25$
- ◆5 Choose a set of mesh currents for the circuit of Fig. 3-37b and then systematically eliminate variables in the resultant set of equations to determine i_x .

Fig. 3-33 See Drill Prob. 3-12.

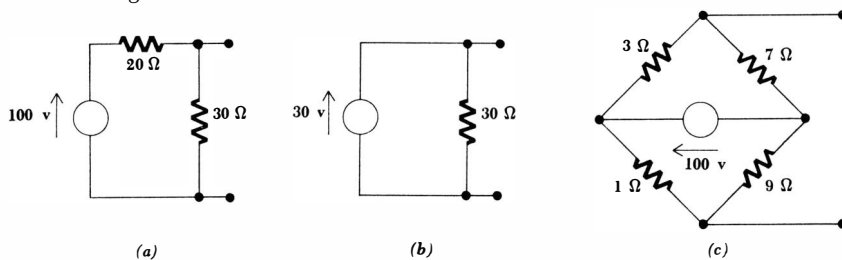
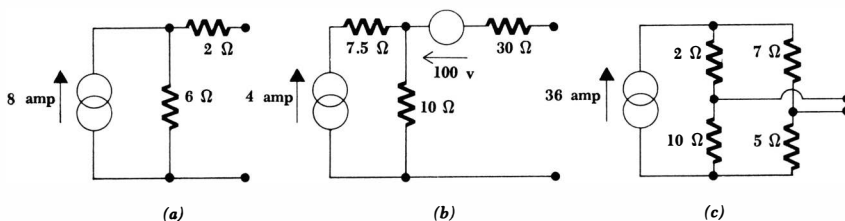

Fig. 3-34 See Drill Prob. 3-13.



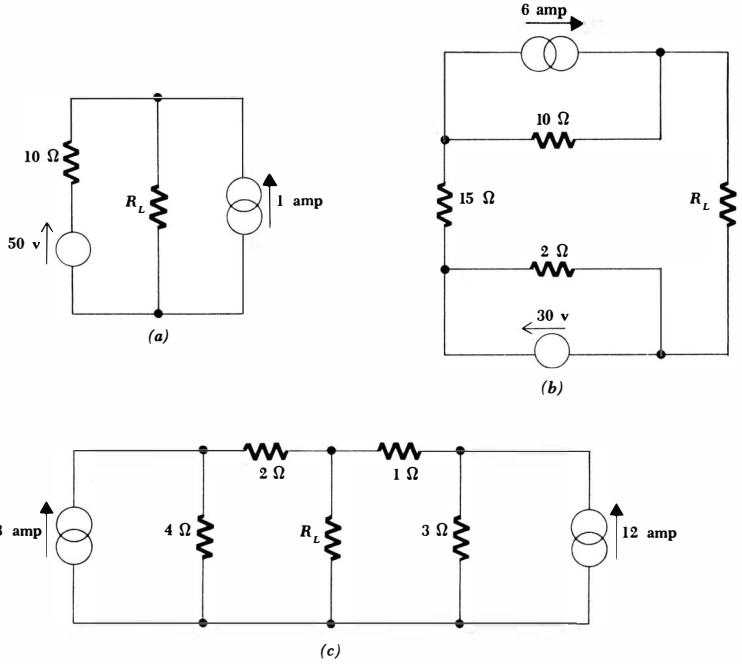

Fig. 3-35 See Drill Prob. 3-14.

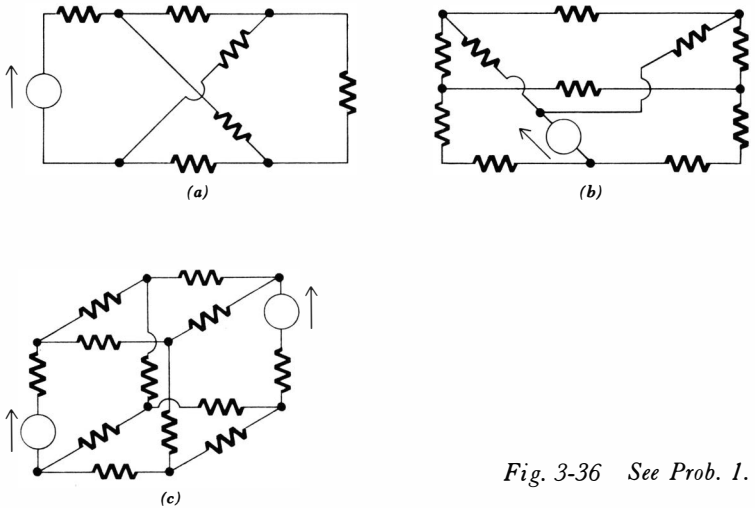

Fig. 3-36 See Prob. 1.

93 *Some Useful Techniques of Circuit Analysis*

◆6 Evaluate the following determinants:

(a)
$$\begin{vmatrix} 1 & 2 & 3 \\ 2 & 3 & 1 \\ 3 & 1 & 2 \end{vmatrix}$$

(b)
$$\begin{vmatrix} 4 & 0 & 0 & 0 \\ 0 & 4 & 0 & 0 \\ 0 & 0 & 4 & 0 \\ 0 & 0 & 0 & 4 \end{vmatrix}$$

(c)
$$\begin{vmatrix} 0 & 1 & -1 \\ 1 & 0 & 1 \\ -1 & 1 & 0 \end{vmatrix}$$

(d)
$$\begin{vmatrix} 1 & -2 & -2 & -1 \\ 1 & -2 & -2 & 1 \\ -1 & -2 & -2 & -1 \\ 1 & 2 & -2 & -1 \end{vmatrix}$$

7 The lamp in the circuit of Fig. 3-38 is nonlinear and has a resistance equal to 50 times the value of the current through it (in ohms and amperes). (a) Assign mesh currents, write the two mesh equations, and find the lamp current by elimination of variables. (b) Is Cramer's rule applicable to this set of nonlinear simultaneous equations? (c) By what factor does the lamp current increase if the source voltage is doubled?

◆8 Find i_x in the circuits shown in Fig. 3-39a and b.

9 Redraw the circuit of Fig. 3-40 in planar form and find the power delivered by each source.

10 Construct a circuit to which this set of mesh equations may apply:

$$5i_1 - 2i_2 = 4 \quad -2i_1 + 7i_2 - 3i_3 = 5 \quad -3i_2 + 4i_3 = 0$$

◆11 Find e_x in the circuit shown in Fig. 3-41a.

12 Find i_x in the circuit shown in Fig. 3-41b.

◆13 Find the power delivered to the 3-ohm resistor in the circuit of Fig. 3-42a.

14 The circuit diagram shown in Fig. 3-42b represents the electrical system of

Fig. 3-37 (a) See Prob. 3. (b) See Prob. 5.

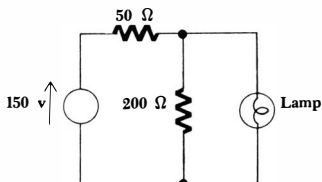
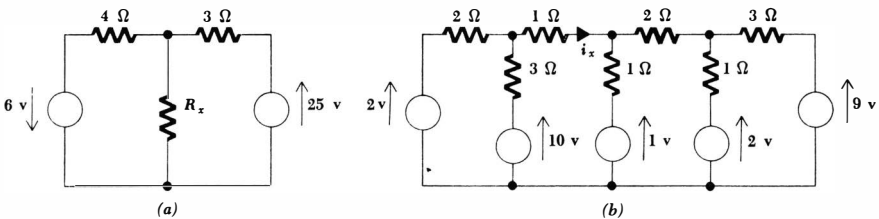

Fig. 3-38 See Prob. 7.

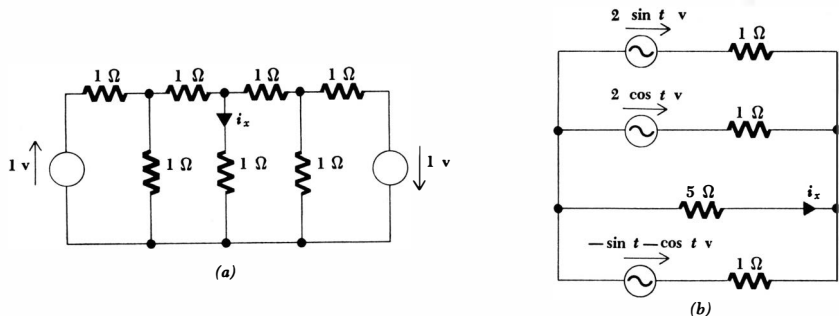

Fig. 3-39 See Prob. 8.

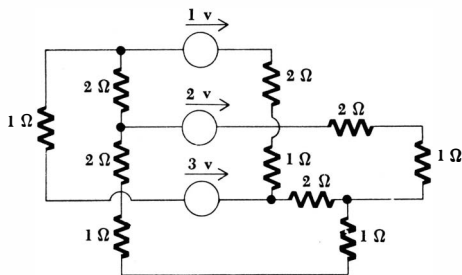

Fig. 3-40 See Prob. 9.

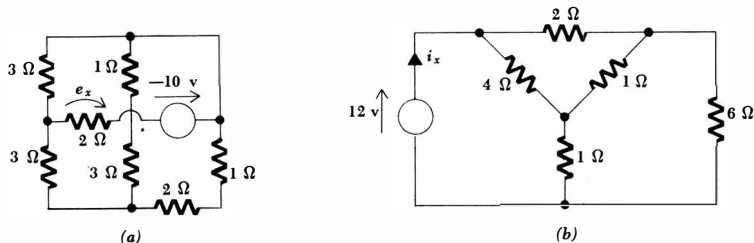

Fig. 3-41 (a) See Prob. 11. (b) See Prob. 12.

an automobile having certain accessories. Determine the power delivered to or furnished by each of the six main elements and find the total power lost in the internal resistances of the two sources.

- ◆15 The diagram of Fig. 3-43 represents a load of 0.03 ohm being supplied by two batteries in parallel. Each battery is composed of three cells in series; the voltage of a cell is represented by an ideal 2.1-volt source and the resistance of a cell by a resistance of 0.02 ohm. One cell has reached the end of its useful life, however, showing a voltage of only 1.8 volts and hav-

- ◆21 By making repeated source transformations, find both the practical current source and the practical voltage source which are equivalent to each of the general sources shown in Fig. 3-47.
- 22 Solve for the current in the 2-ohm branch of Fig. 3-48a by first using mesh equations for the circuit as drawn and then by replacing the two voltage sources by current sources and writing a single nodal equation.
- ◆23 Solve for the power delivered to the 10-ohm resistor in the circuit of Fig. 3-48b by first using current sources and nodal equations and then using voltage sources and mesh equations.

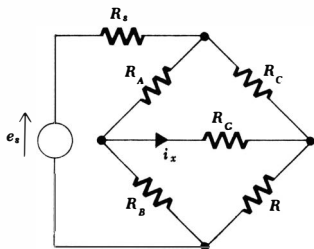

Fig. 3-44 See Prob. 16.

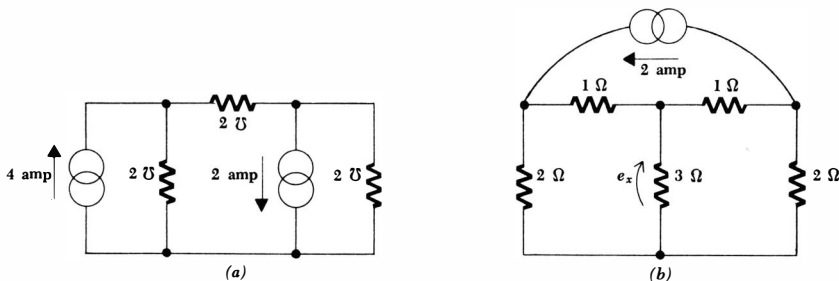
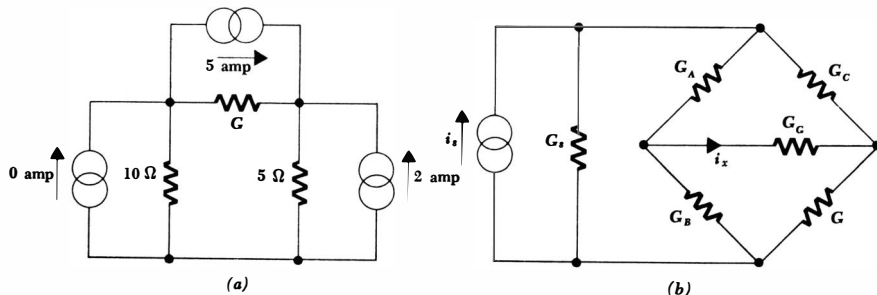

Fig. 3-45 (a) See Prob. 17. (b) See Prob. 18.

Fig. 3-46 (a) See Prob. 19. (b) See Prob. 20.



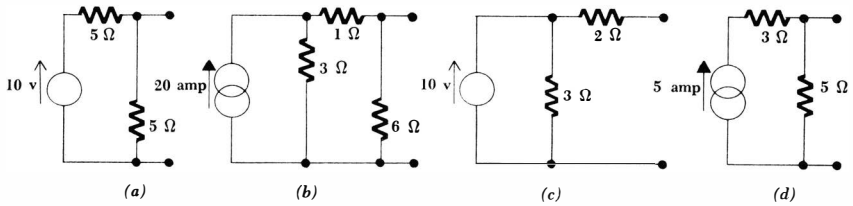

Fig. 3-47 See Prob. 21.

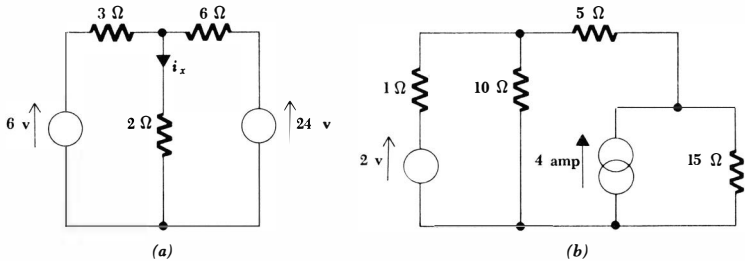

Fig. 3-48 (a) See Prob. 22. (b) See Probs. 23 and 24.

- 24 Rework Prob. 23 by making repeated source transformations until a single practical voltage source is in series with the 10-ohm resistor.
- 25 Show that when equivalent voltage and current sources are connected to identical loads, the power dissipated internally in the two sources is in general different. Is the power delivered by each source to its load the same? Is the total power delivered by each source to its load plus its internal resistance the same? Under what conditions are the internally dissipated powers equal?
- 26 (a) Show that the normal procedure for making source transformations does not work for ideal sources. (b) Assume that an ideal voltage source of 100 volts is in series with a 50-ohm resistor. The voltage, current, and power in the resistor are easily obtained. Now let us transform the *ideal* voltage source into an ideal current source by a slightly underhanded procedure. Insert an additional resistance R in series with the source, transform to a practical current source, and then find the voltage across the 50-ohm load in terms of R . Finally, take the limit as R becomes vanishingly small and show that the resultant answer is correct. This method is always applicable, but its use is often an admission that the easy way to solve the problem has been overlooked.
- ◆27 Experimental measurements on a practical source show that it provides 50 volts across a 100-ohm load and 60 volts across a 200-ohm load. Determine equivalent voltage and current sources.

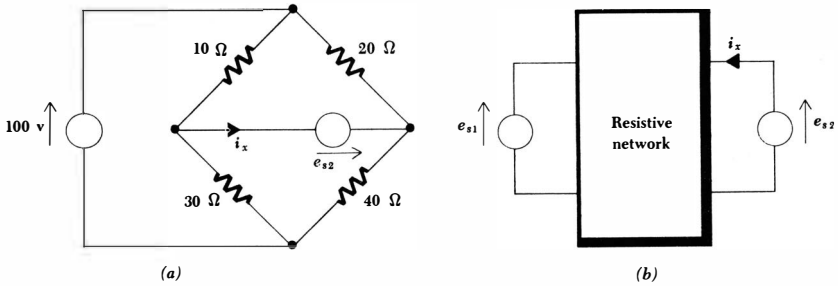

Fig. 3-49 (a) See Prob. 30. (b) See Prob. 31.

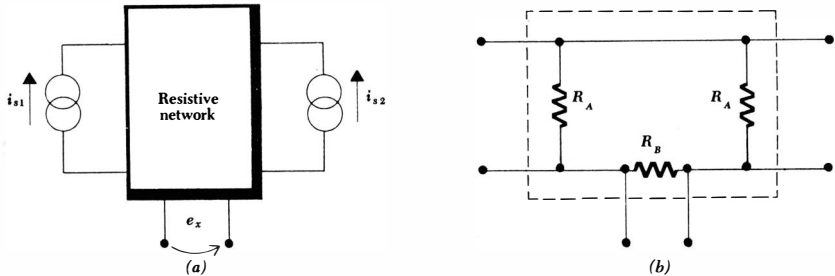
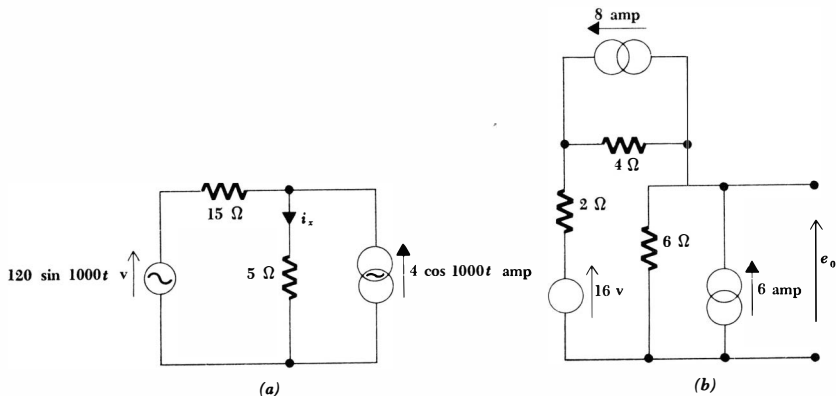

Fig. 3-50 See Prob. 32.

- 28 A practical source can provide 200 volts on open circuit and 5 amp in a short circuit. Determine equivalent voltage and current sources.
- 29 If an automobile battery delivers 12 volts on open circuit but only 11 volts to a load drawing 20 amp, how much power will be dissipated inside the battery when a 0.1-ohm resistor is connected across the battery terminals?
- 30 Find the value of e_{s2} for which i_x is zero in the circuit of Fig. 3-49a.
- 31 The resistive network in the sketch of Fig. 3-49b is of unknown configuration. Experimental measurements show that if $e_{s1} = e_{s2} = 12$ volts, then $i_x = 3$ amp; but if $e_{s1} = 12$ volts and $e_{s2} = 6$ volts, then $i_x = 1$ amp. (a) Find e_{s2} if $e_{s1} = 12$ volts and $i_x = 0$. (b) Find e_{s1} if $e_{s2} = 3$ volts and $i_x = 2$ amp. (c) Try to find a two-resistor network which has all the above characteristics.
- 32 The resistive network shown in the sketch of Fig. 3-50a has the following characteristics: if $i_{s1} = i_{s2} = 9$ amp, then $e_x = 0$; but if $i_{s1} = 9$ amp and $i_{s2} = -9$ amp, then $e_x = 20$ volts. (a) Find e_x if $i_{s1} = 9$ amp and $i_{s2} = 0$. (b) Find e_x if $i_{s1} = 3$ amp and $i_{s2} = -6$ amp. (c) Assume that the network has the form sketched in Fig. 3-50b and show that any combination of R_A and R_B for which $9R_A R_B = 10R_B + 20R_A$ will satisfy the conditions of the problem.

- ◆33 A certain network contains two sources and a large number of resistors, one of which is designated R_L . Measurements at R_L with a wattmeter show that it receives 20 watts when only the first source is active and 80 watts when only the second source is active. What power does it receive when both sources are operating?
- 34 A certain nonlinear resistor has a resistance which is proportional to the current flowing in it, $R = 100i$. Assume two 100-volt ideal sources in series with it and calculate the current through it. Show that superposition does not apply in this simple nonlinear circuit.
- ◆35 In the circuit of Fig. 3-51a, determine the first value of t greater than zero at which $i_x = 0$.
- 36 (a) Assume an ideal voltage source e_s in series with a fixed internal resistance R_s and an adjustable load resistance R_L . Let the voltage and current at R_L be e and i . R_L is now varied from 0 to ∞ , and e is plotted versus i . Determine de/di and describe the curve, giving intercepts. (b) A laboratory source is measured,† and it is found that the plot of e versus i is very closely given by $e = 200\sqrt{2 - i}$. What practical voltage source is a reasonable approximation for this source for small currents (say less than 1 amp)?
- ◆37 Find e_o in the circuit of Fig. 3-51b.
- 38 Find and draw the Thévenin equivalent of each of the two-terminal networks shown in Fig. 3-52.
- ◆39 A certain network, composed of resistors and energy sources, is supplying power to a load resistor R_L . Experimental measurements show that a load voltage of 8 volts is obtained when $R_L = 8$ ohms, 6 volts when $R_L = 4$ ohms, 4 volts when $R_L = 2$ ohms, and 0 volts when $R_L = 0$. Determine equivalent practical voltage and current sources for the network.
- 40 When a high-resistance voltmeter is used to measure the voltage across a physical battery, a reading of 24 volts is obtained. However, when a volt-

Fig. 3-51 (a) See Prob. 35. (b) See Prob. 37.



100 The Resistive Circuit

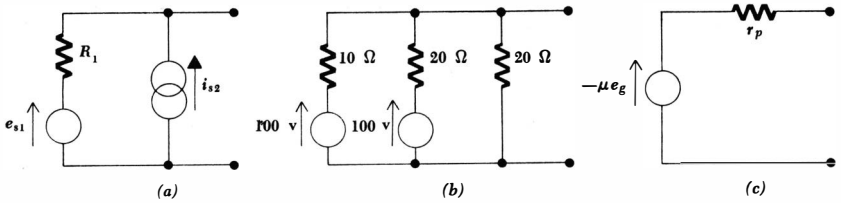

Fig. 3-52 See Probs. 38 and 44.

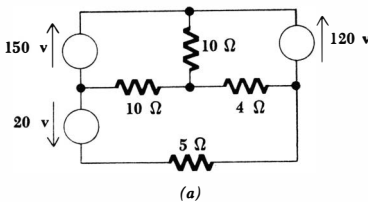
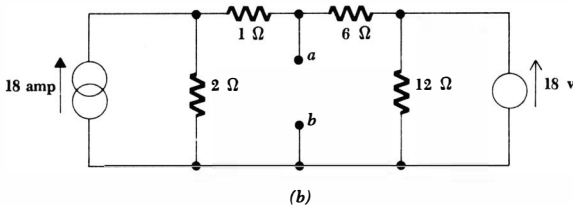

Fig. 3-53 (a) See Prob. 41.
(b) See Prob. 42.



meter having a resistance of 500 ohms is used, a voltage of 22 volts is read. Draw a Thévenin equivalent for the battery if the voltmeters are both assumed to be accurate.

- 41 Use Thévenin's theorem to find the power delivered to the 5-ohm resistor in the circuit shown in Fig. 3-53a.
- 42 Find the Thévenin equivalent at terminals *a-b* of the circuit shown in Fig. 3-53b.
- 43 The circuits shown in the two parts of this problem contain an ideal source having a slightly more sophisticated nature than those we have previously considered. They provide a current or voltage which is proportional to a current or voltage in another branch of the circuit. Such sources are called *dependent* sources and are common in electronics and control circuits. The Thevenin and Norton equivalents may be found by determining e_{oc} and i_{sc} , but a note of warning is necessary. The voltage or current on which the source depends often changes as the load changes; in particular, it is different under short- and open-circuit terminations. Caution must also be exercised in applying the superposition theorem, for the theorem states that only *ideal* (independent) sources are to be killed;

101 *Some Useful Techniques of Circuit Analysis*

- dependent sources may or may not be inactive. (a) For the circuit of Fig. 3-54a, show that $e_{oc} = e_s/(1 - gR)$, $i_{sc} = e_s/R$, and draw the Thévenin and Norton equivalents. (b) Find the Norton and Thévenin equivalents of the circuit of Fig. 3-54b.
- ◆44 Determine and draw the Norton equivalent of each of the two-terminal networks shown in Fig. 3-52 by applying Norton's theorem. The Thévenin equivalent should not be determined first.
- 45 Determine the Thévenin equivalent of the network shown in Fig. 3-55. One source is a dependent generator.
- 46 (a) In the circuit shown in Fig. 3-56a, R_2 is a nonlinear resistor; assume that $R_2 = 100i_2$ and $i_2 \geq 0$. Write mesh equations and determine i_2 . (b) Replace the linear portion of the network (everything to the left of R_2) by its Thévenin equivalent and determine i_2 by a single mesh equation. Compare with the answer to part a above. (c) Thévenin's theorem may not be used to replace any network containing nonlinear elements by an equivalent. As a simple example, consider a 100-volt d-c source in series with the nonlinear R_2 defined above. The current in R_2 may be designated i_2 ; see Fig. 3-56b. Show that the open-circuit voltage is 100 volts. It is

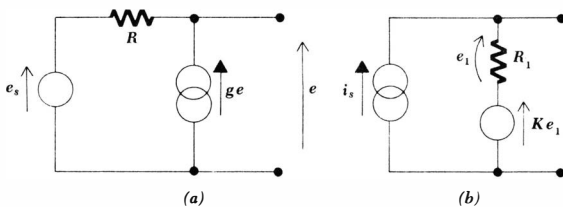

Fig. 3-54 See Prob. 43.

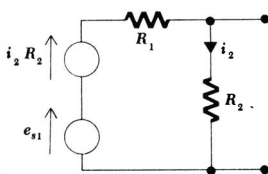
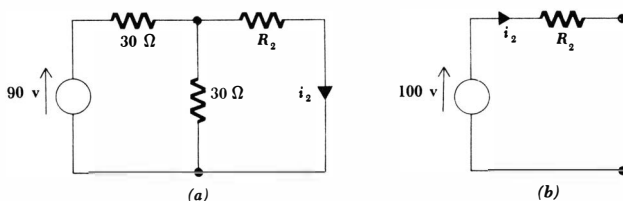

Fig. 3-55 See Prob. 45.

Fig. 3-56 See Prob. 46.



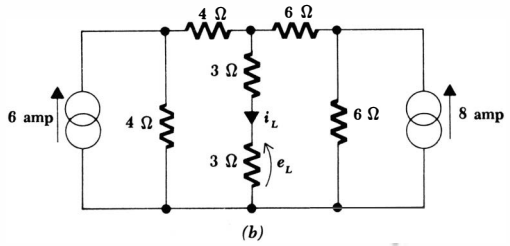
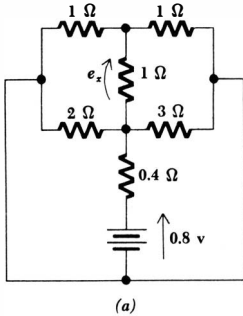

Fig. 3-57 (a) See Prob. 47. (b) See Prob. 48.

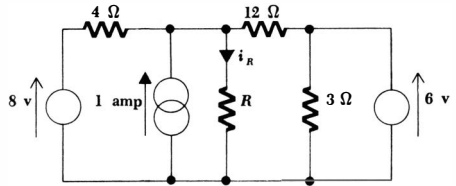

Fig. 3-58 See Prob. 49.

obviously impossible to determine R_{th} by merely killing the voltage source and looking at the circuit, because the value of R_2 depends on the current through it, which is unknown. Suppose, however, that we get clever and find the short-circuit current. Show that it is 1 amp. If we now let $R_{th} = e_{oc}/i_{sc} = 100$ ohms, we obtain an “equivalent” circuit. Show that it is not equivalent by finding the current delivered to a 150-ohm load in the original circuit and in the Thévenin (non)-equivalent.

- 47 After contemplating various possible methods, find e_x in the circuit of Fig. 3-57a by the simplest procedure.
- ◆48 Find i_L and e_L in the circuit of Fig. 3-57b by: (a) nodal equations; (b) source transformations and mesh equations; (c) superposition; (d) source transformations and superposition; (e) Thévenin equivalent; (f) Norton equivalent. (g) Which method is the quickest?
- 49 In the circuit shown in Fig. 3-58, what value must R have if i_R is: (a) 1 amp? (b) $\frac{1}{2}$ amp? (c) What voltage source must be placed in series with R to reduce i_R to zero?

Part
Two:
The
Transient
Circuit

Chapter 4 Inductance and Capacitance

4-1 INTRODUCTION

We are now ready to begin the second major portion of our study of circuits. In this chapter we shall introduce two new simple circuit elements whose voltage-current relationships depend on a changing voltage or current. Before we begin this new study, it will be worthwhile to pause for a moment and look back upon our study of the analysis of resistive circuits. A little bit of philosophical review will aid in our understanding of the coming work.

After setting up a satisfactory system of units, we began our discussion of electric circuits by defining current, voltage, and three simple circuit elements. The ideal voltage and current sources were called active elements and the linear resistor was termed a passive element, although our definitions of "active" and "passive" are still slightly fuzzy and need to be brought into sharper focus. We think of an active element as one which is capable of delivering power to some external device, and the two ideal sources were classified as such; a passive element, however, is capable only of receiving power and the resistor falls into this category. The energy it receives is transformed into heat.

Each of these three elements was defined by placing certain restrictions on its voltage-current relationship. In the case of the ideal voltage source, for example, the terminal voltage must be completely independent of the current drawn from its terminals; an ideal current source was defined as having a current which is totally independent of its voltage. The linear resistor, however, must have a linear voltage-current relationship such that $e = iR$.

After defining these three elements, we then considered circuits composed of these three different building blocks. In general, we used only constant voltages and currents, although several problems and examples indicated that all our results were equally valid for time-varying voltages and currents. This is true, and now that we have gained a familiarity with the basic analytical techniques by treating only the resistive circuit, we may begin to consider the much

more interesting and practical problems in which inductance and capacitance are present and in which both the forcing functions and the responses usually vary with time.

4-2 THE INDUCTOR

Both the inductor, which is the subject of this and the following section, and the capacitor, which is discussed later in the chapter, are passive elements which are capable of storing and delivering finite amounts of energy. Unlike an ideal source, they cannot provide an unlimited amount of energy or a finite average power. This latter concept may be used to improve upon our definition of an *active element* as being one which is capable of delivering an infinite amount of energy and of a *passive element* as one which is not capable of delivering infinite energy.

Although we shall define an inductor and inductance strictly from a circuit point of view, that is, by a voltage-current equation, a few comments about the historic development of the magnetic field may provide a better understanding of the definition. In the early 1800s the Danish scientist Oersted showed that a current-carrying conductor produced a magnetic field, or that compass needles were affected in the presence of a current-carrying conductor. In France, shortly thereafter, Ampere made some careful measurements which demonstrated that this magnetic field was linearly related to the current which produced it. The next step occurred some twenty years later when the English experimentalist Michael Faraday and the American inventor Joseph Henry discovered almost simultaneously¹ that a changing magnetic field could produce a voltage in a neighboring circuit. They showed that this voltage was proportional to the time rate of change of the current which produced the magnetic field. The constant of proportionality we now call the *inductance*, symbolized by L , and therefore

$$e = L \frac{di}{dt} \quad (4-1)$$

where we must realize that e and i are both functions of time. When we wish to emphasize this, we may do so by using the symbols $e(t)$ and $i(t)$.

The circuit symbol for the inductor is shown in Fig. 4-1, and it should be noted that the directions of the sense arrows for e and i are identical with those for the resistor. The unit in which inductance is measured is the *henry*,² and the defining equation shows that the henry is just a shorter expression for a volt-second per ampere. An inductance of 5 henrys is abbreviated as $L = 5 \text{ h}$, and the dimensional symbol for inductance is $[ML^2Q^{-2}]$.

The inductor whose inductance is defined by Eq. (4-1) is a mathematical model; it is an ideal element which we may use to approximate the behavior of a real device. A physical inductor is constructed by winding a length of wire

¹ Faraday won.

² An empty victory.

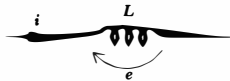

Fig. 4-1 The voltage and current sense arrows are shown on the circuit symbol for an inductor in directions such that $e = L di/dt$.

into a coil. This serves effectively to increase the current which is causing the magnetic field and also to increase the “number” of neighboring circuits into which Faraday’s voltage may be induced. The result of this twofold effect is that the inductance of a coil is approximately proportional to the square of the number of complete turns made by the conductor out of which it is formed. An inductor, or “coil,” which has the form of a long helix of very small pitch is found to have an inductance of $\mu N^2 A/s$, where A is the cross-sectional area, s is the axial length of the helix, N is the number of complete turns of wire, and μ (μ) is a constant of the material inside the helix, called the permeability. For air, $\mu = \mu_0 = 4\pi \times 10^{-7}$ henry/m.

Physical inductors should be on view in an accompanying circuits laboratory course, and the topics concerned with the magnetic flux, permeability, and the methods of using the characteristics of the physical coil to calculate a suitable inductance for the mathematical model are treated in both physics courses and courses in electromagnetic field theory.

Let us now scrutinize Eq. (4-1) to determine some of the electrical characteristics of this mathematical model. This equation shows that the voltage across an inductor is proportional to the time rate of change of the current through it. In particular, it shows that there is no voltage across an inductor carrying a constant current, regardless of the magnitude of this current. Accordingly, a direct current flowing through an inductor produces no voltage across the inductor; we may view an inductor as a “short circuit to d-c.” Another fact which is evidenced by this equation is related to an infinite rate of change of the inductor current, such as that caused by an abrupt change in current from one finite value to some other finite value. This sudden or discontinuous change in the current must be associated with an infinite voltage across the inductor. In other words, if we wish to produce an abrupt change in an inductor current, we must apply an infinite voltage. Although an infinite-voltage forcing function might be acceptable theoretically, it can never be a part of the phenomena displayed by a real physical device. As we shall see shortly, an abrupt change in the inductor current also requires an abrupt change in the energy stored in the inductor, and this sudden change in energy requires infinite power at that instant; infinite power is again not a part of the real physical world. In order to avoid infinite voltage and infinite power, an inductor current must not be allowed to jump instantaneously from one value to another. If an attempt is made to open-circuit a physical inductor through which a finite current is flowing, an arc may appear across the switch. The stored energy is dissipated in ionizing the air in the path of the arc. We shall not consider any circuits at the present time in which an inductor is suddenly open-circuited. It should be pointed out,

however, that we shall remove this restriction later when we hypothesize the existence of a voltage forcing function or response which does become infinite instantaneously.

Equation (4-1) may also be interpreted (and solved, if necessary) by graphical methods. Let us assume a current which is zero prior to $t = -1$, increases linearly to 1 amp in the next second, remains at 1 amp for 2 sec, and then decreases to zero in the next second, remaining zero thereafter. The current waveform is sketched as a function of time in Fig. 4-2a. If this current is flowing in a 3-henry inductor, and if the voltage and current directions are assigned to satisfy the passive sign convention, then we may use Eq. (4-1) to obtain the voltage waveform. Since the current is zero and constant for $t < -1$, the voltage is zero in this interval. The current then begins to increase at the linear rate of 1 amp/sec, and thus a constant voltage of 3 volts is produced. During the following 2-sec interval, the current is constant and the voltage is therefore zero. The final decrease of the current causes a negative 3 volts and no response thereafter. The voltage waveform is sketched in Fig. 4-2b on the same time scale.

Let us now investigate the effect of a more rapid rise and decay of the current between the zero and 1-amp values. If the intervals required for the rise and fall are decreased to 0.1 sec, then the derivative must be ten times as great in magnitude. This condition is shown in the current and voltage sketches of Fig. 4-3a and b. In the voltage waveforms of Figs. 4-2b and 4-3b, it is interesting to note that the area under each voltage pulse is 3 volt-sec.

A further decrease in the length of these two intervals will produce a proportionally larger voltage magnitude, but only within the interval in which the current is increasing or decreasing. An abrupt change in the current will cause the infinite voltage "spikes" (each having an area of 3 volt-sec) that are sug-

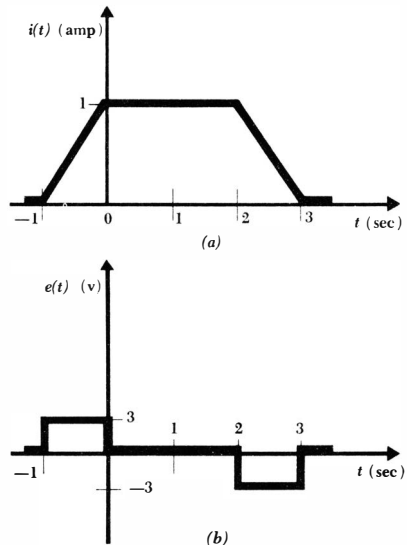

Fig. 4-2 (a) The current waveform in a certain 3-h inductor. (b) The corresponding voltage waveform.

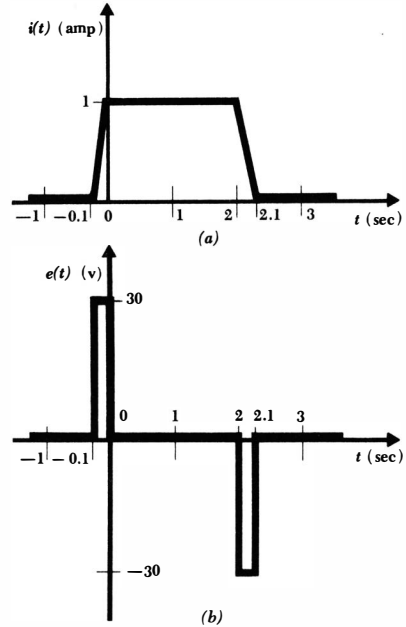

Fig. 4-3 (a) The time required for the current of Fig. 4-2a to change from 0 to 1 and from 1 to 0 is decreased by a factor of 10. (b) The resultant voltage waveform. Note that the pulse widths are exaggerated slightly, for clarity.

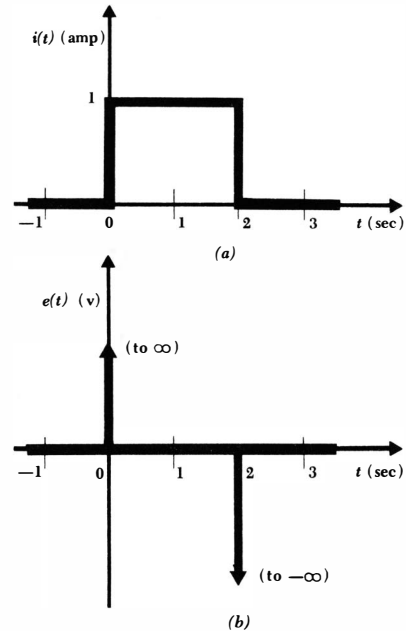

Fig. 4-4 (a) The time required for the current of Fig. 4-2a to change from 0 to 1 and from 1 to 0 is decreased to zero; the rise and fall are abrupt. (b) The associated voltage across the inductor consists of a positive and negative infinite spike.

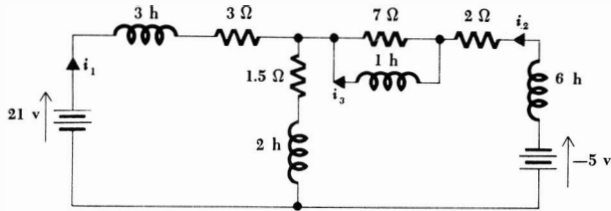

Fig. 4-5 See Drill Prob. 4-1.

gested by the waveforms of Fig. 4-4a and b; or, from the opposite point of view, these infinite voltage spikes are required to produce the abrupt changes in the current. It will be convenient later to provide such infinite voltages (and currents), and we shall then call them “impulses”; for the next several chapters, however, we shall stay closer to physical reality by not permitting infinite voltage, current, or power. An abrupt change in the inductor current is therefore impossible.

Drill Problems

4-1 For the circuit of Fig. 4-5, find the current: (a) i_1 ; (b) i_2 ; (c) i_3 .

Ans. -4 amp; -4 amp; 6 amp

4-2 The current through a 0.1-henry inductor varies in the following manner as a function of time: $i = 0$ for $t \leq 0$; $i = 3 \sin 30 \pi t$ amp for $0 \leq t \leq 0.1$ sec; $i = 20(t - 0.1)$ for $0.1 \leq t \leq 0.2$; $i = 2$ for $0.2 \leq t$. Assuming a passive sign convention, find the inductor voltage at: (a) $t = 0.05$ sec; (b) $t = 0.15$ sec; (c) $t = 0.25$ sec.

Ans. 0 volts; 0 volts; 2 volts

4-3 INTEGRAL RELATIONSHIPS FOR THE INDUCTOR

We have defined the inductance by a simple differential equation

$$e = L \frac{di}{dt} \quad (4-2)$$

and we have been able to draw several conclusions about the characteristics of an inductor from this relationship. For example, we have found that we may consider an inductor as a short circuit to direct current, and we have agreed that we cannot permit an inductor current to change abruptly from one value to another because this would require that an infinite voltage and power be associated with the inductor. The defining equation for an inductance still contains more information, however. Rewritten in a slightly different form,

$$di = \frac{1}{L} e dt$$

it invites integration. Let us first consider the limits to be placed on the two integrals. We desire the current i at time t , and this pair of quantities therefore provides the upper limits on the integrals appearing on the left and right side of the equation, respectively; the lower limits may also be kept general by merely assuming that the current is $i(t_0)$ at time t_0 . Thus

$$\int_{i(t_0)}^{i(t)} di = \frac{1}{L} \int_{t_0}^t e dt$$

or $i(t) - i(t_0) = \frac{1}{L} \int_{t_0}^t e dt$

and $i(t) = \frac{1}{L} \int_{t_0}^t e dt + i(t_0)$ (4-3)

Equation (4-2) expresses the inductor voltage in terms of the current, whereas Eq. (4-3) gives the current in terms of the voltage. Other forms are also possible for this latter equation. We may write the integral as an indefinite integral and include a constant of integration k ,

$$i(t) = \frac{1}{L} \int e dt + k$$
 (4-4)

or we may suppress the constant of integration, trusting our excellent memories to make us replace it whenever necessary,

$$i(t) = \frac{1}{L} \int e dt$$
 (4-5)

We may also assume that we are solving a realistic problem in which the selection of t_0 as $-\infty$ ensures no current in the inductor. Thus, if $i(t_0) = i(-\infty) = 0$, then

$$i(t) = \frac{1}{L} \int_{-\infty}^t e dt$$
 (4-6)

Let us consider the use of these several integrals by working a simple example. Suppose that the voltage across a 2-henry inductor is known to be $6 \cos 5t$; what information is then available about the inductor current? From Eq. (4-3),

$$i(t) = \frac{1}{2} \int_{t_0}^t 6 \cos 5t dt + i(t_0)$$

or $i(t) = \frac{1}{2} \sin 5t - \frac{1}{2} \sin 5t_0 + i(t_0) = 0.6 \sin 5t - 0.6 \sin 5t_0 + i(t_0)$

The first term indicates that the inductor current varies sinusoidally; the second and third terms together merely represent a constant which becomes known when the current is numerically specified at some instant of time. Let us assume that the statement of our example problem also shows us that the current is 1 amp at $t = -\pi/2$ sec. We thus identify t_0 as $-\pi/2$, $i(t_0)$ as 1, and find that

$$i(t) = 0.6 \sin 5t - 0.6 \sin (-2.5\pi) + 1$$

or $i(t) = 0.6 \sin 5t + 1.6$

111 Inductance and Capacitance

We may obtain the same result from Eq. (4-4). We have

$$i(t) = 0.6 \sin 5t + k$$

and we establish the numerical value of k by forcing the current to be 1 amp at $t = -\pi/2$,

$$1 = 0.6 \sin (-2.5\pi) + k$$

or $k = 1 + 0.6 = 1.6$

and $i(t) = 0.6 \sin 5t + 1.6$

once more.

We may also use Eq. (4-5), but it should be noted that the constant 1.6 will be missing from our current expression if we forget to include the constant of integration. For this reason, Eq. (4-5) is a poor expression to use before our familiarity with integrals is such that a constant is automatically included whether it is shown explicitly or not.

Equation (4-6) is going to cause trouble; it is based on the assumption that the current is zero when $t = -\infty$. To be sure, this must be true in the real physical world, but we are working in the land of the mathematical model; our elements and forcing functions are all idealized. The difficulty arises after we integrate,

$$i(t) = 0.6 \sin 5t \Big|_{-\infty}^t$$

and attempt to evaluate the integral at the lower limit,

$$i(t) = 0.6 \sin 5t - 0.6 \sin (-\infty)$$

The sine of $\pm\infty$ is indeterminate; we might just as well represent it by an unknown constant,

$$i(t) = 0.6 \sin 5t + k$$

and we see that this result is identical with that which we obtained when we assumed an arbitrary constant of integration in Eq. (4-4).

We should not make any snap judgments, based on this example, as to which single form we are going to use forever; each has its advantages, depending on the problem and the application. Equation (4-3) represents a long, general method, but it shows clearly that the constant of integration is a current. Equation (4-4) is a somewhat more concise expression of Eq. (4-3), but the nature of the integration constant is suppressed. Equation (4-5) is still simpler, but the missing integration constant must not be forgotten. Finally, Eq. (4-6) is an excellent expression since no constant is necessary; however, it applies only when the current is zero at $t = -\infty$ and when the analytical expression for the current is not indeterminate there.

Let us now turn our attention to power and energy. The absorbed power is given by the current-voltage product

$$p = ai = Li \frac{di}{dt} \quad \text{watts}$$

The energy w_L accepted by the inductance is stored in the magnetic field around the coil and is expressed by the integral of the power over the desired time interval,

$$\int_{t_0}^t p \, dt = L \int_{t_0}^t i \frac{di}{dt} dt = L \int_{i(t_0)}^{i(t)} i \, di = \frac{1}{2}L\{[i(t)]^2 - [i(t_0)]^2\}$$

and thus

$$w_L(t) - w_L(t_0) = \frac{1}{2}L\{[i(t)]^2 - [i(t_0)]^2\} \quad \text{joules} \quad (4-7)$$

where we have again assumed that the current is $i(t_0)$ at time t_0 . In using the energy expression, it is customary to assume that a value of t_0 is selected at which the current is zero; it is also customary to assume that the energy is zero at this time. We then have simply

$$w_L(t) = \frac{1}{2}Li^2 \quad (4-8)$$

where we now understand that our reference for zero energy is any time at which the inductor current is zero. At any subsequent time at which the current is zero, we also find no energy stored in the coil. Whenever the current is not zero, and regardless of its direction or sign, energy is stored in the inductance. It follows, therefore, that power must be delivered to the inductor for a part of the time and recovered from the inductor later. All the stored energy may be recovered from an ideal inductor; there are no storage charges or agent's commissions in the mathematical model. A physical coil, however, must be constructed out of real wire and thus will always have a resistance associated with it. Energy can no longer be stored and recovered without loss.

These ideas may be illustrated by a simple example. In Fig. 4-6 an inductance of 3 henrys is shown in series with a resistance of 0.1 ohm and a sinusoidal current source. The resistor may be interpreted, if we wish, as the resistance of the wire which must be associated with the physical coil.

The voltage across the resistor is given by

$$e_R = iR = 1.2 \sin \frac{\pi}{6} t$$

and the voltage across the inductance is found by applying the defining equation for an inductance,

$$e_L = L \frac{di}{dt} = 3 \frac{d}{dt} \left(12 \sin \frac{\pi}{6} t \right) = 6\pi \cos \frac{\pi}{6} t$$

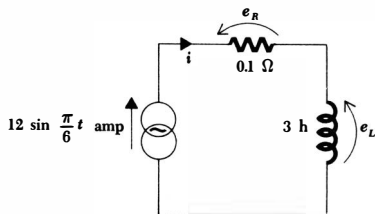

Fig. 4-6 A sinusoidal current is applied as a forcing function to a series RL circuit.

113 Inductance and Capacitance

The energy stored in the inductor is

$$w_L = \frac{1}{2}Li^2 = 216 \sin^2 \frac{\pi}{6} t$$

and it is apparent that this energy increases from zero at $t = 0$ to 216 joules at $t = 3$ sec. During the next 3 sec, the energy leaves the inductor completely. Let us see what price we have paid in this coil for the privilege of storing and removing 216 joules in these few seconds. The power dissipated in the resistor is easily found as

$$p_R = i^2 R = 14.4 \sin^2 \frac{\pi}{6} t$$

and the energy converted into heat in the resistor within this 6-sec interval is therefore

$$w_R = \int_0^6 p_R dt = \int_0^6 14.4 \sin^2 \frac{\pi}{6} t dt$$

or
$$w_R = \int_0^6 14.4^{(1/2)} \left(1 - \cos \frac{\pi}{3} t\right) dt = 43.2 \text{ joules}$$

This represents 20 per cent of the maximum stored energy and is a reasonable value for many coils having this large an inductance. For coils having an inductance of about $100 \mu\text{h}$, we should expect a figure closer to 3 per cent.

Let us now recapitulate by listing several characteristics of an inductor which result from its defining equation:

1. There is no voltage across an inductor if the current through it is not changing with time. An inductance is therefore a short circuit to d-c.
2. A finite amount of energy can be stored in an inductor even if the voltage across the inductance is zero, such as when the current through it is constant.
3. It is impossible to change the current through an inductor by a finite amount in zero time, for this requires an infinite voltage across the inductor. It will be advantageous later to *hypothesize* that such a voltage may be generated and applied to an inductor, but for the present we shall avoid such a forcing function or response. An inductor resists an abrupt change in the current through it in a manner analogous to the way a mass resists an abrupt change in its velocity.
4. The inductor never dissipates energy, but only stores it. Although this is true for the mathematical model, it is not true for a physical inductor.

Drill Problems

4-3 Find the inductance of a coil in which: **(a)** a current of 10 ma represents a stored energy of $0.1 \mu\text{joule}$; **(b)** a current increasing linearly from 0 to 0.03 amp in 15 msec produces a voltage of 5 mv; **(c)** a current

of 10 ma increasing at the rate of 2 amp/sec represents a power flow into the coil of $60 \mu\text{w}$.

Ans. 3 mh; 2.5 mh; 2 mh

4-4 Find the energy stored in a 5-henry inductance at $t = 2$ sec if: (a) the current through the inductance is $4 \cos(2\pi t/3)$ amp; (b) the voltage across the inductance is $10e^{-t/4}$ volts, and $i_L = 0$ at $t = 0$; (c) the voltage is $10 e^{-t/4}$ volts, but $i_L = 0$ at $t = 0.5$ sec.

Ans. 12.2 joules; 10 joules; 24.8 joules

4-5 The voltage across a certain 2-henry coil is known in the interval between $t = 0$ and $t = 5$ sec:

$$e = 10t \quad 0 < t < 3$$

$$e = 5 \quad 3 < t < 5$$

No detailed information is available concerning the voltage outside this time interval. Find the inductor current at: (a) $t = 1$ if $i(0) = 0$; (b) $t = 3$ if $i(1) = 5$ amp; (c) $t = 5$ if $i(4) = 2$ amp.

Ans. 2.5 amp; 4.5 amp; 25 amp

4-4 THE CAPACITOR

Our final passive circuit element is the capacitor. We shall define *capacitance* C by the voltage-current relationship

$$i = C \frac{de}{dt} \quad (4-9)$$

where e and i satisfy the conventions for a passive element, as shown in Fig. 4-7. From Eq. (4-9), we may determine the dimensions of capacitance as ampere-seconds per volt, or coulombs per volt, but we shall now define the *farad* as one coulomb per volt. The unit of capacitance is thus the farad; the dimensional symbol for capacitance is $[M^{-1}L^{-2}T^2Q^2]$, and 5 farads is abbreviated 5 f.

The capacitor whose capacitance is defined by Eq. (4-9) is again a mathematical model of a real device. The construction of the physical device is suggested by the circuit symbol shown in Fig. 4-7, in much the same way as the helical symbol used for the inductor represents the coiled wire in that physical element. A capacitor, physically, consists of two conducting surfaces on which

Fig. 4-7 The current and voltage sense arrows are shown on the circuit symbol for a capacitor in directions such that $i = C de/dt$.

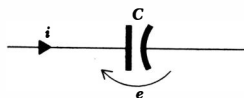

charge may be stored, separated by a thin insulating layer which has a very large resistance. If we assume that this resistance is sufficiently large that it may be considered infinite, then equal and opposite charges placed on the capacitor “plates” can never recombine, at least by any path *within* the element. Let us visualize some external device, such as a current source, connected to this capacitor and causing a positive current to flow into one plate of the capacitor and out of the other plate. Equal currents are entering and leaving the two terminals of the element, and this is no more than we expect for any circuit element. Now let us examine the interior of the capacitor. The positive current entering one plate represents positive charge moving toward that plate through its terminal lead; this charge cannot pass through the interior of the capacitor, and it therefore accumulates on the plate. As a matter of fact, the current and the increasing charge are related by the familiar equation

$$i = \frac{dq}{dt}$$

Now let us pose ourselves a troublesome problem by considering this plate as an overgrown node and applying Kirchhoff’s current law. It apparently does not hold; current is approaching the plate from the external circuit, but it is not flowing out of the plate into the “internal circuit.” This dilemma bothered a famous Scottish scientist about a century ago, and the unified electromagnetic theory which James Clerk Maxwell then developed hypothesizes a “displacement current” which is present wherever an electric field or voltage is varying with time. The displacement current flowing internally between the capacitor plates is exactly equal to the conduction current flowing in the capacitor leads; Kirchhoff’s current law is therefore satisfied if we include both conduction and displacement currents. However, circuit analysis is not concerned with this internal displacement current, and since it is fortunately equal to the conduction current, we may consider Maxwell’s hypothesis as relating the conduction current to the changing voltage across the capacitor. The relationship is linear, and the constant of proportionality is obviously the capacitance C ,

$$i_{disp} = i = C \frac{de}{dt}$$

A capacitor constructed of two parallel conducting plates of area A , separated a distance d , has a capacitance $C = \epsilon A/d$, where ϵ is the permittivity, a constant of the insulating material between the plates, and where the linear dimensions of the conducting plates are all very much greater than d . For air or vacuum, $\epsilon = \epsilon_0 = 8.854 \times 10^{-12}$ farad/m $\doteq (1/36\pi) \times 10^{-9}$ farad/m.

The concepts of the electric field, displacement current, and the more generalized form of Kirchhoff’s current law are more appropriate subjects for courses in physics and electromagnetic field theory, as is the determination of a suitable mathematical model to represent a specific physical capacitor.

Several important characteristics of our new mathematical model can be discovered from the defining equation (4-9). A constant voltage across a capacitor requires zero current passing through it; a capacitor is thus an “open circuit to d-c.” This fact is certainly represented by the capacitor symbol. It is also

apparent that a sudden jump in the voltage requires an infinite current. Just as we outlawed abrupt changes in inductor currents and the associated infinite voltages on physical grounds, we shall not permit abrupt changes in capacitor voltage; the infinite current (and infinite power) which results is nonphysical. We shall remove this restriction at the time we assume the existence of the current impulse.

The capacitor voltage may be expressed in terms of the current by integrating Eq. (4-9). We first obtain

$$de = \frac{1}{C} i dt$$

and then integrate between the times t_0 and t and between the corresponding voltages $e(t_0)$ and $e(t)$,

$$e(t) = \frac{1}{C} \int_{t_0}^t i dt + e(t_0) \quad (4-10)$$

Equation (4-10) may also be written as an indefinite integral plus a constant of integration,

$$e(t) = \frac{1}{C} \int i dt + k \quad (4-11)$$

or with the constant of integration suppressed but not forgotten,

$$e(t) = \frac{1}{C} \int i dt \quad (4-12)$$

Finally, in many real problems, t_0 may be selected as $-\infty$ and $e(-\infty)$ as zero,

$$e(t) = \frac{1}{C} \int_{-\infty}^t i dt \quad (4-13)$$

Since the integral of the current over any time interval is the charge accumulated in that period on the capacitor plate into which the current is flowing, it is apparent that capacitance might have been defined as

$$q = Ce$$

The similarity between the several integral equations introduced in this section and those appearing in our discussion of inductance is striking and suggests that the duality we observed between mesh and nodal equations in resistive networks may be extended to include inductance and capacitance as well. The principle of duality will be presented and discussed later in this chapter.

As an illustration of the use of the several integral equations displayed above, let us find the capacitor voltage which is associated with the current shown graphically in Fig. 4-8a. We shall assume that the single 20-amp rectangular pulse of 2 sec duration is applied to a 5-farad capacitor. Interpreting Eq. (4-10) graphically, we know that the difference between the values of the voltage at t and t_0 is proportional to the area under the current curve between these same two values of time. The proportionality constant is $1/C$. The area can be ob-

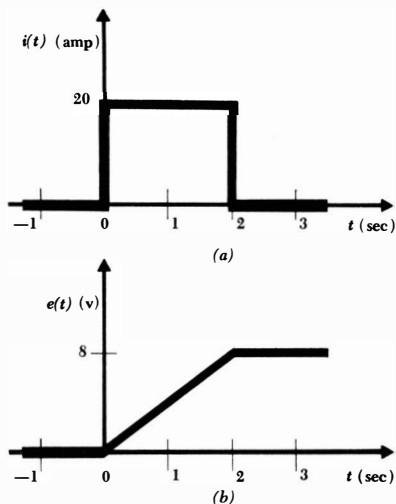

Fig. 4-8 (a) The current waveform applied to a 5-farad capacitor. (b) The resultant voltage waveform, easily obtained by integrating graphically.

tained from Fig. 4-8a by inspection for desired values of t_0 and t . Thus, if $t_0 = -0.5$ and $t = 0.5$,

$$e(0.5) = 2 + e(-0.5)$$

or, if $t_0 = 0$ and $t = 3$,

$$e(3) = 8 + e(0)$$

We may express our results more generally by dividing the interesting range of time into several intervals. Let us select our starting point t_0 prior to zero time. Then the first interval of t is selected between t_0 and zero,

$$e(t) = 0 + e(t_0) \quad t_0 \leq t \leq 0$$

and since our waveform implies that no current has ever been applied to this capacitor since the Creation,

$$e(t_0) = 0$$

and, thus,

$$e(t) = 0 \quad t \leq 0$$

If we now consider the time interval represented by the rectangular pulse, we obtain

$$e(t) = 4t \quad 0 \leq t \leq 2$$

For the semi-infinite interval following the pulse, we have

$$e(t) = 8 \quad 2 \leq t$$

The results for these three intervals therefore provide us with analytical expressions for the capacitor voltage at any time after $t = t_0$; the time t_0 , however, may be selected as early as we wish. The results are expressed much more simply in a sketch than by these analytical expressions, as shown in Fig. 4-8*b*.

The power delivered to a capacitor is

$$p = ei = Ce \frac{de}{dt}$$

and the energy stored in its electric field is therefore

$$\int_{t_0}^t p dt = C \int_{t_0}^t e \frac{de}{dt} dt = C \int_{e(t_0)}^{e(t)} e de = \frac{1}{2} C \{ [e(t)]^2 - [e(t_0)]^2 \}$$

and thus

$$w_C(t) - w_C(t_0) = \frac{1}{2} C \{ [e(t)]^2 - [e(t_0)]^2 \} \quad \text{joules} \quad (4-14)$$

where the stored energy is $w_C(t_0)$ and the voltage is $e(t_0)$ at t_0 . If we select a zero-energy reference at t_0 , implying that the capacitor voltage is also zero at that instant, then

$$w_C(t) = \frac{1}{2} C e^2 \quad (4-15)$$

Let us consider a simple numerical example. As sketched in Fig. 4-9, we shall assume a sinusoidal voltage source in parallel with a 1-megohm resistor and a 20- μ f capacitor. The parallel resistor may be assumed to represent the resistance of the insulator or dielectric between the capacitor plates. The current through the resistor is

$$i_R = \frac{e}{R} = 10^{-4} \sin 2\pi t$$

and the current through the capacitor is

$$i_C = C \frac{de}{dt} = 20 \times 10^{-6} \frac{d}{dt} (100 \sin 2\pi t) = 4\pi \times 10^{-3} \cos 2\pi t$$

We next obtain the energy stored in the capacitor,

$$w_C = \frac{1}{2} C e^2 = 0.1 \sin^2 2\pi t$$

and see that the energy increases from zero at $t = 0$ to a maximum of 0.1 joule at $t = \frac{1}{4}$ sec and then decreases to zero in another $\frac{1}{4}$ sec. During this $\frac{1}{2}$ -sec interval, the energy dissipated in the resistor is

$$w_R = \int_0^{0.5} p_R dt = \int_0^{0.5} 10^{-2} \sin^2 2\pi t dt = 2.5 \times 10^{-3} \text{ joule}$$

Thus, an energy equal to 2.5 per cent of the maximum stored energy is lost in the process of storing and removing the energy in the ideal capacitor. Much smaller values are possible in "low-loss" capacitors, but these smaller percentages are customarily associated with much smaller capacitors.

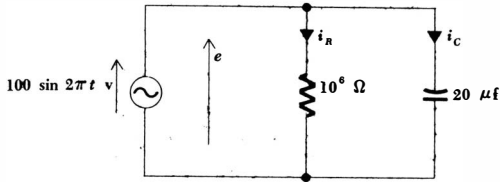

Fig. 4-9 A sinusoidal voltage source is applied to a parallel RC network. See also Drill Prob. 4-9.

Some of the important characteristics of a capacitor are now apparent:

1. The current through a capacitor is zero if the voltage across it is not changing with time. A capacitor is therefore an open circuit to d-c.
2. A finite amount of energy can be stored in a capacitor even if the current through the capacitor is zero, such as when the voltage across it is constant.
3. It is impossible to change the voltage across a capacitor by a finite amount in zero time, for this requires an infinite current through the capacitor. It will be advantageous later to *hypothesize* that such a current may be generated and applied to a capacitor, but for the present we shall avoid such a forcing function or response. A capacitor resists an abrupt change in the voltage across it in a manner analogous to the way a spring resists an abrupt change in its displacement.
4. The capacitor never dissipates energy, but only stores it. Although this is true for the mathematical model, it is not true for a physical capacitor.

It is interesting to anticipate our discussion of duality by rereading the previous four statements with certain words replaced by their "duals." If capacitor and inductor, capacitance and inductance, voltage and current, across and through, open circuit and short circuit, spring and mass, and displacement and velocity are interchanged (in either direction), the four statements previously given for inductors are obtained.

Drill Problems

4-6 For the circuit of Fig. 4-10, find the voltage: (a) e_1 ; (b) e_2 ; (c) e_3 .

Ans. 4 volts; -4 volts; 6 volts

Fig. 4-10 See Drill Prob. 4-6.

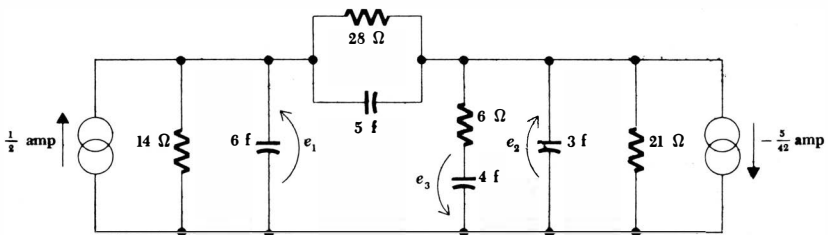

4-7 The voltage across a 0.1-farad capacitor varies in the following manner as a function of time: $e = 0$ for $t \leq 0$; $e = 3 \sin 30\pi t$ for $0 \leq t \leq 0.1$ sec; $e = 20(t - 0.1)$ for $0.1 \leq t \leq 0.2$; $e = 2$ volts for $0.2 \leq t$. Assuming a passive sign convention, find the capacitor current at: (a) $t = 0.05$ sec; (b) $t = 0.15$ sec; (c) $t = 0.25$ sec.

Ans. 0 amp; 0 amp; 2 amp

4-8 Find the current flowing through a 0.1- μf capacitor in which: (a) the voltage is increasing linearly at the rate of 100 volts each msec; (b) charge is increasing on one plate and decreasing on the other at the rate of 0.03 coulomb/sec; (c) the energy storage is remaining constant at 10 mjoules.

Ans. 0 ma; 10 ma; 30 ma

4-9 In the circuit shown in Fig. 4-9, the sinusoidal source is changed to $e(t) = 100 \sin 4\pi t$ volts. Find: (a) the maximum energy which is stored in the capacitor; (b) the energy dissipated in the resistor during the time interval necessary to store and remove the maximum capacitor energy; (c) the energy supplied by the source during this same time interval.

Ans. 1.25 mjoules; 1.25 mjoules; 100 mjoules

4-10 The current through an ideal 4-farad capacitor is known in the interval between $t = -5$ and $t = 5$ sec:

$$i = 5t \quad -5 < t < 1$$

$$i = 2.5 \quad 1 < t < 5$$

The current waveform is unknown outside this time interval. Find the capacitor voltage at: (a) $t = -3$ if $e(-5) = 0$; (b) $t = 1$ if $e(-3) = 2.5$ volts; (c) $t = 5$ if $e(3) = 1$ volt.

Ans. 2.25 volts; -10 volts; -2.5 volts

4-5 KIRCHHOFF'S LAWS AND THE CIRCUIT EQUATIONS AGAIN

Now that we have added the inductor and capacitor to our list of passive circuit elements, we need to examine the ways in which our thinking must be modified when these elements are included in circuits containing resistors and time-varying forcing functions. Specifically, we must determine whether or not the methods we have developed in studying resistive circuit analysis are still valid. It will also be convenient to learn how to replace series and parallel combinations of either of these elements with a simpler equivalent, just as we did with resistors in Chap. 2. Let us look first at Kirchhoff's two laws and, incidentally, justify the simple equations we wrote for several of the examples in the last two sections.

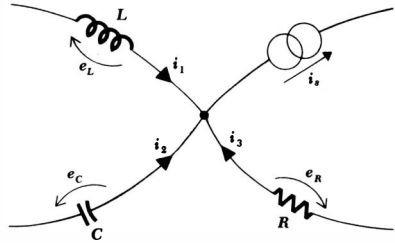

Fig. 4-11 A portion of a circuit used to demonstrate the application of Kirchhoff's current law in the general case.

Kirchhoff's current law was first stated and discussed in Sec. 2-3; it is simply a statement that the algebraic sum of all the currents entering (or leaving) any node must be equal to zero. Its earlier justification was based on the conservation of charge; if current is entering a small closed surface surrounding any node, then the charge within that surface must be increasing. A node still cannot store charge,³ and hence Kirchhoff's current law still holds, regardless of the types of elements connected to the node or of the time-varying nature of the several currents.

As an example of the application of this law, consider the portion of a circuit shown in Fig. 4-11. In terms of the four branch currents, we may write

$$i_1 + i_2 + i_3 - i_s = 0$$

If a correctly sensed voltage is assigned to each of the passive elements, then an equivalent expression in terms of these voltages is

$$\frac{1}{L} \int e_L dt + C \frac{de_C}{dt} + \frac{e_R}{R} - i_s = 0$$

The first term in the equation is understood to represent any of the integral expressions for inductor current developed in Sec. 4-3.

Now let us reexamine Kirchhoff's voltage law. This law states that the algebraic sum of all the voltages about any closed path is equal to zero. In Chap. 2, it was pointed out that this law is not true in general electromagnetic-field problems; it is true for circuits, only because the inductance of a physical coil is treated as a two-terminal characteristic. Thus, inductors cause us trouble with Kirchhoff's voltage law, just as capacitors caused us some misgivings concerning Kirchhoff's current law. These laws are truly no more than axioms; when we speak of circuit analysis, we assume that the mathematical models with which we are provided (or provide ourselves) have been chosen in such a way that some involved electromagnetic-field problem is reduced to a circuit model for which Kirchhoff's laws are valid. This assumption is implicit in all circuit analysis.

³ When we extended the concept of a node to include one plate of a capacitor, we then established a "node" which was capable of storing charge; simultaneously, we also provided ourselves with a Maxwellian displacement current which could flow through the interior of the capacitor.

122 *The Transient Circuit*

For the network shown in Fig. 4-12, clockwise travel about the closed path in applying Kirchhoff's voltage law yields

$$e_R - e_L + e_C - e_s = 0$$

and in terms of the branch currents shown,

$$Ri_R - L \frac{di_L}{dt} + \frac{1}{C} \int i_C dt - e_s = 0$$

Once again, it should be pointed out that the integral may take on any of the several possible equivalent forms.

Now let us extend the procedures we have derived for reducing various combinations of resistors into one equivalent resistor to the analogous cases of inductors and capacitors. We shall first consider an ideal voltage source applied to the series combination of N inductors, as shown in Fig. 4-13a. We desire a single equivalent inductor L_{eq} which may replace the series combination such that the source current $i(t)$ is unchanged. The equivalent circuit is sketched in Fig. 4-13b. For the original circuit

$$\begin{aligned} e_s &= e_1 + e_2 + \cdots + e_N \\ &= L_1 \frac{di}{dt} + L_2 \frac{di}{dt} + \cdots + L_N \frac{di}{dt} \\ &= (L_1 + L_2 + \cdots + L_N) \frac{di}{dt} \end{aligned}$$

or, written more concisely,

$$e_s = \sum_{n=1}^N e_n = \sum_{n=1}^N L_n \frac{di}{dt} = \frac{di}{dt} \sum_{n=1}^N L_n$$

But for the equivalent circuit we have

$$e_s = L_{eq} \frac{di}{dt}$$

and thus the equivalent inductance is

$$L_{eq} = L_1 + L_2 + \cdots + L_N \quad \text{or} \quad L_{eq} = \sum_{n=1}^N L_n$$

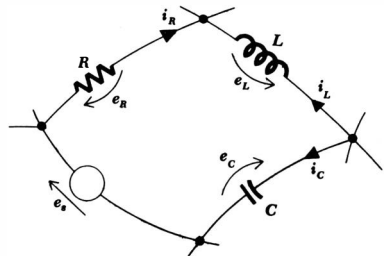

Fig. 4-12 One mesh in a general network which is used to demonstrate the general use of Kirchhoff's voltage law.

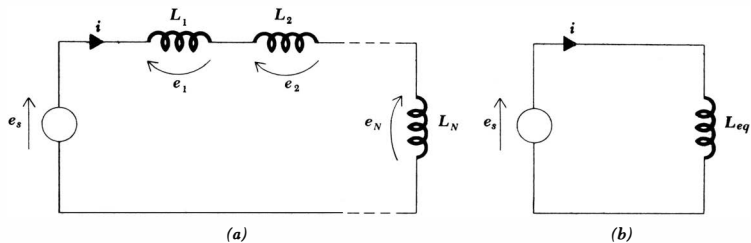

Fig. 4-13 (a) A circuit containing N inductors in series. (b) The desired equivalent circuit, in which $L_{eq} = L_1 + L_2 + \dots + L_N$.

The inductance which is equivalent to several inductances connected in series is simply the sum of the series inductances. This is exactly the same result we obtained for resistors in series.

The combination of a number of parallel inductors is accomplished by writing the single nodal equation for the original circuit, shown in Fig. 4-14a,

$$\begin{aligned}
 i_s &= \sum_{n=1}^N i_n = \sum_{n=1}^N \left[\frac{1}{L_n} \int_{t_0}^t e \, dt + i_n(t_0) \right] \\
 &= \left[\sum_{n=1}^N \frac{1}{L_n} \right] \int_{t_0}^t e \, dt + \sum_{n=1}^N i_n(t_0)
 \end{aligned}$$

and comparing it with the result for the equivalent circuit of Fig. 4-14b,

$$i_s = \frac{1}{L_{eq}} \int_{t_0}^t e \, dt + i_s(t_0)$$

Since Kirchhoff's current law demands that the value of i_s at t_0 be equal to the sum of the branch currents at t_0 , the two integral terms must be equal; hence,

$$L_{eq} = \frac{1}{1/L_1 + 1/L_2 + \dots + 1/L_N}$$

Fig. 4-14 (a) The parallel combination of N inductors. (b) The equivalent circuit, where $L_{eq} = 1/(1/L_1 + 1/L_2 + \dots + 1/L_N)$.

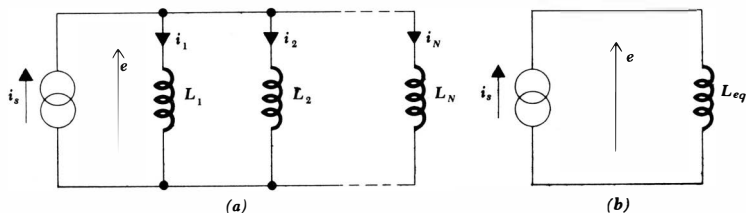

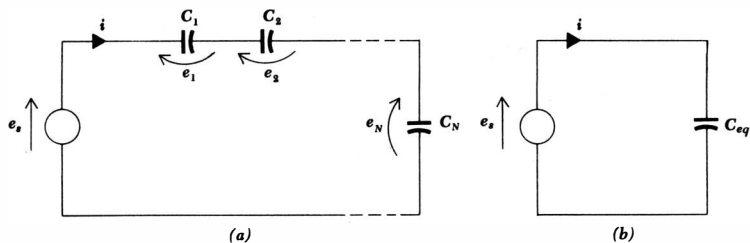

Fig. 4-15 (a) A circuit containing N capacitors in series. (b) The desired equivalent, $C_{eq} = 1/(1/C_1 + 1/C_2 + \dots + 1/C_N)$.

For the special case of two inductors in parallel,

$$L_{eq} = \frac{L_1 L_2}{L_1 + L_2}$$

and we note that inductors in parallel combine exactly as do resistors in parallel.

In order to find a capacitance which is equivalent to N capacitors in series, we use the circuit of Fig. 4-15a and its equivalent Fig. 4-15b to write

$$\begin{aligned} e_s &= \sum_{n=1}^N e_n = \sum_{n=1}^N \left[\frac{1}{C_n} \int_{t_0}^t i \, dt + e_n(t_0) \right] \\ &= \left[\sum_{n=1}^N \frac{1}{C_n} \right] \int_{t_0}^t i \, dt + \sum_{n=1}^N e_n(t_0) \end{aligned}$$

and
$$e_s = \frac{1}{C_{eq}} \int_{t_0}^t i \, dt + e_s(t_0)$$

However, Kirchhoff's voltage law establishes the equality of $e_s(t_0)$ and the sum of the capacitor voltages at t_0 ; thus

$$C_{eq} = \frac{1}{1/C_1 + 1/C_2 + \dots + 1/C_N}$$

Thus capacitors in series combine as do resistors in parallel.

Finally, the circuits of Fig. 4-16 enable us to establish the value of the

Fig. 4-16 (a) The parallel combination of N capacitors. (b) The equivalent circuit, where $C_{eq} = C_1 + C_2 + \dots + C_N$.

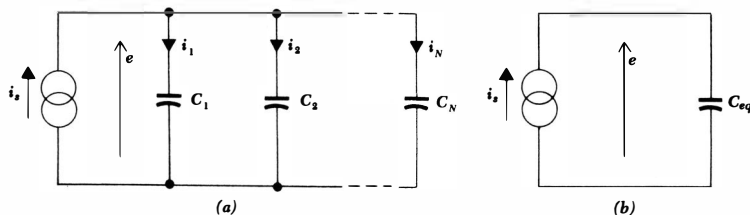

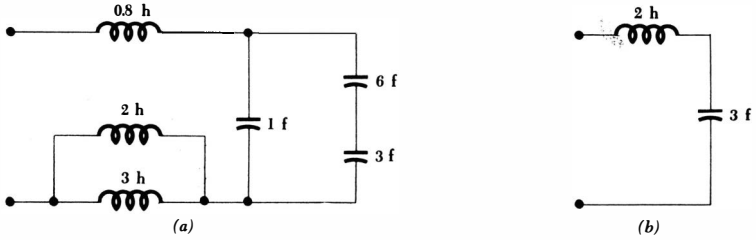

Fig. 4-17 (a) A given LC network. (b) A simpler equivalent network.

capacitance which is equivalent to N parallel capacitors as

$$C_{eq} = C_1 + C_2 + \dots + C_N$$

and it is no great source of amazement to note that capacitors in parallel combine in the same manner in which we combine resistors in series, that is, by simply adding all the individual capacitances.

As an example in which some simplification may be achieved by combining like elements, consider the network of Fig. 4-17a. The 6- and 3-farad capacitors are first combined into a 2-farad equivalent, and this capacitor is then combined with the 1-farad element with which it is in parallel to yield an equivalent capacitance of 3 farads. In addition, the 3- and 2-henry inductors are replaced by an equivalent 1.2-henry inductor which is then added to the 0.8-henry element to give a total equivalent inductance of 2 henrys. The much simpler (and probably less expensive) equivalent network is shown in Fig. 4-17b.

The network shown in Fig. 4-18 contains three inductors and three capacitors, but no series or parallel combinations of either the inductors or the capacitors can be achieved. Simplification of this network cannot be accomplished at this time.

Next let us turn to mesh and nodal analysis. Since we already know that we may safely apply Kirchhoff's laws, we should have little difficulty in writing down a set of equations for either mesh or nodal analysis. They will be constant-coefficient linear integrodifferential equations, however, which are hard enough to pronounce, let alone solve. Consequently, we shall write them now to gain familiarity with the use of Kirchhoff's laws in RLC circuits and discuss the solution of the simpler cases in the following chapters.

Let us attempt to write the three mesh equations for the circuit of Fig. 4-19.

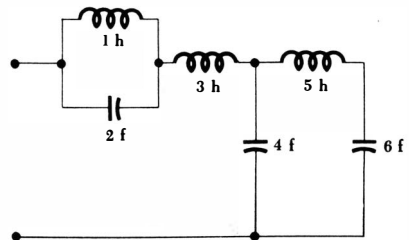

Fig. 4-18 An LC network in which no series or parallel combinations of either the inductors or the capacitors are possible.

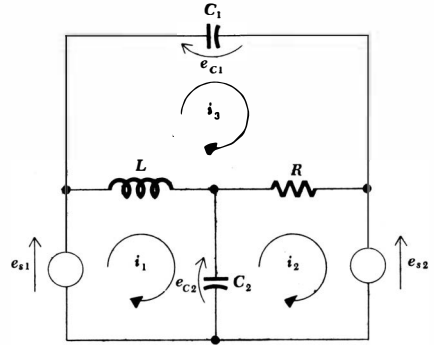

Fig. 4-19 A three-mesh RLC circuit with mesh currents assigned.

Three clockwise mesh currents are chosen and Kirchoff's voltage law is applied to the first mesh,

$$-e_{s1} + L \frac{d}{dt}(i_1 - i_3) + \frac{1}{C_2} \int_{t_0}^t (i_1 - i_2) dt + e_{c2}(t_0) = 0$$

or
$$L \frac{di_1}{dt} + \frac{1}{C_2} \int_{t_0}^t i_1 dt - \frac{1}{C_2} \int_{t_0}^t i_2 dt - L \frac{di_3}{dt} = e_{s1} - e_{c2}(t_0)$$

Note that the voltage $e_{c2}(t_0)$ across C_2 at $t = t_0$ appears in the mesh equation as a (constant) source voltage. The simplified results for meshes 2 and 3 are

$$-\frac{1}{C_2} \int_{t_0}^t i_1 dt + \frac{1}{C_2} \int_{t_0}^t i_2 dt + Ri_2 - Ri_3 = -e_{s2} + e_{c2}(t_0)$$

$$-L \frac{di_1}{dt} - Ri_2 + Ri_3 + L \frac{di_3}{dt} + \frac{1}{C_1} \int_{t_0}^t i_3 dt = -e_{c1}(t_0)$$

These are the promised integrodifferential equations, and we shall not attempt their solution at this time. It is worthwhile pointing out, however, that when the two voltage forcing functions are sinusoidal functions of time it will be possible to define a voltage-current ratio (called impedance) for each of the three passive elements. The factors operating on the three mesh currents in the mesh equations will then become simple multiplying factors, and the equations will be linear algebraic equations once again. These we may solve by determinants or a simple elimination of variables as before.

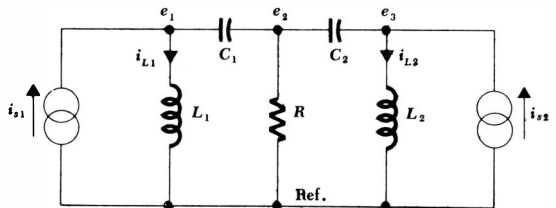

Fig. 4-20 A four-node RLC circuit with node voltages assigned.

In a similar manner, we may also write nodal equations in this more general case. There are four nodes in the circuit shown in Fig. 4-20; one is selected as the reference node, and three voltages are chosen between each of the remaining nodes and the reference. For easy reference, the two inductor currents are also indicated. Kirchhoff's current law is applied at each of these nodes:

$$\begin{aligned} \frac{1}{L_1} \int_{t_0}^t e_1 dt + C_1 \frac{de_1}{dt} - C_1 \frac{de_2}{dt} &= i_{s1} - i_{L1}(t_0) \\ -C_1 \frac{de_1}{dt} + \frac{1}{R} e_2 + (C_1 + C_2) \frac{de_2}{dt} - C_2 \frac{de_3}{dt} &= 0 \\ -C_2 \frac{de_2}{dt} + C_2 \frac{de_3}{dt} + \frac{1}{L_2} \int_{t_0}^t e_3 dt &= i_{s2} - i_{L2}(t_0) \end{aligned}$$

Here again, a solution of this system of integrodifferential equations is too difficult to attempt now. We should feel confident, however, that either the mesh or nodal equations can be written for a network of any complexity.

Drill Problems

4-11 In the circuit shown in Fig. 4-21a, $i_1 = 3e^{-2t}$ and $i_2 = 5t$. Find: (a) e_2 ; (b) e_{sA} ; (c) e_{sB} .

Ans. $-18e^{-2t} - 10t$ volts; $6e^{-2t} - 35t$ volts; $6e^{-2t} - 10t$ volts

4-12 For the circuit of Fig. 4-21b, $e_1 = 4 \sin 6t$ and $e_2 = 8 - 12 \sin 6t$. Find: (a) i_4 ; (b) i_{sA} ; (c) i_{sB} .

Ans. $-2 + 4 \sin 6t$ amp; $-2 + 4 \sin 6t + 48 \cos 6t$ amp; $2 - 4 \sin 6t - 432 \cos 6t$ amp

4-13 Find the equivalent inductance for each of the inductive networks of Fig. 4-22.

Ans. 2.25 henrys; 1.6 henrys; 3.25 henrys

Fig. 4-21 (a) See Drill Prob. 4-11. (b) See Drill Prob. 4-12.

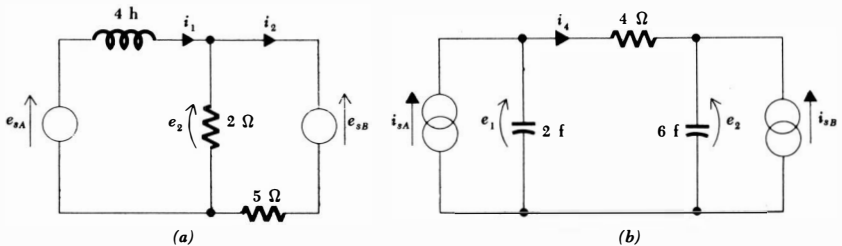

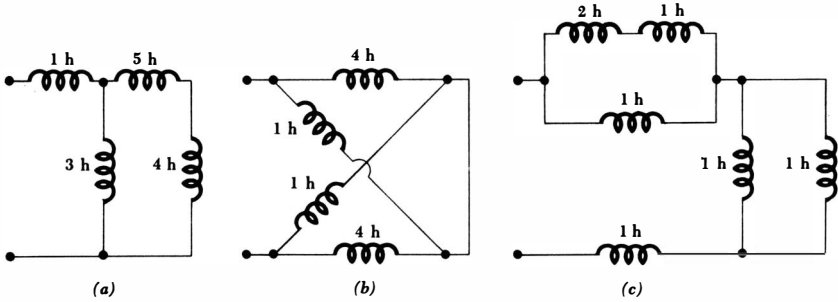

Fig. 4-22 See Drill Prob. 4-13.

4-14 Find the equivalent capacitance for each of the capacitive networks of Fig. 4-23.

Ans. 3.25 farads; 2.25 farads; 1.6 farads

4-6 DUALITY

Duality has been mentioned earlier in connection with resistive circuits and more recently in the discussion of inductance and capacitance; the comments made were introductory and a little offhand. Now we may make an exact definition and then use the definition to recognize or construct dual circuits and thus avoid the labor of analyzing both a circuit and its dual.

We shall define duality in terms of the circuit equations. Two circuits are *duals* if the mesh equations that characterize one of them have the same mathematical form as the nodal equations that characterize the other. They are said to be *exact duals* if each mesh equation of the one circuit is numerically identical with the corresponding nodal equation of the other; the current and voltage variables themselves cannot be identical, of course. *Duality* itself merely refers to any of the properties exhibited by dual circuits.

Let us interpret the definition and use it to construct an exact dual circuit by writing the two mesh equations for the circuit shown in Fig. 4-24. Two mesh

Fig. 4-23 See Drill Prob. 4-14.

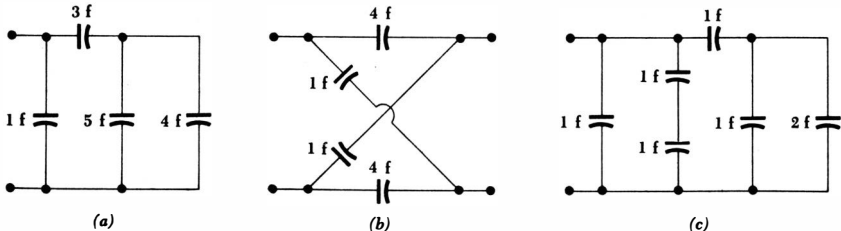
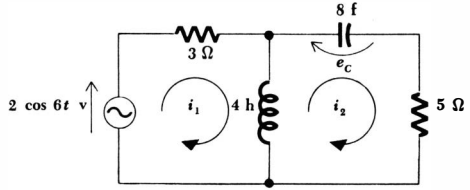

Fig. 4-24 A given circuit to which the definition of duality may be applied to determine the dual circuit.



currents i_1 and i_2 are assigned, and the mesh equations are

$$3i_1 + 4 \frac{di_1}{dt} - 4 \frac{di_2}{dt} = 2 \cos 6t \tag{4-16}$$

$$-4 \frac{di_1}{dt} + 4 \frac{di_2}{dt} + \frac{1}{8} \int_0^t i_2 dt + 5i_2 = -10 \tag{4-17}$$

It should be noted that the capacitor voltage e_c is assumed to be 10 volts at $t = 0$.

We may now construct the two equations which are the mathematical exact duals of Eqs. (4-16) and (4-17). We wish them to be nodal equations, and we thus begin by replacing the mesh currents i_1 and i_2 by two node-to-reference voltages e_1 and e_2 . We obtain

$$3e_1 + 4 \frac{de_1}{dt} - 4 \frac{de_2}{dt} = 2 \cos 6t \tag{4-18}$$

$$-4 \frac{de_1}{dt} + 4 \frac{de_2}{dt} + \frac{1}{8} \int_0^t e_2 dt + 5e_2 = -10 \tag{4-19}$$

and we now seek the circuit represented by these two nodal equations.

Let us first draw a line to represent the reference node, and then we may establish two nodes at which the voltage arrowheads for e_1 and e_2 are located. Equation (4-18) indicates that a current source $2 \cos 6t$ is connected between node 1 and the reference node, oriented to provide a current entering node 1. This equation also shows that a 3-mho conductance appears between node 1 and the reference node. Turning to Eq. (4-19), we first consider the nonmutual terms, or those terms which do not appear in Eq. (4-18), and they instruct us to connect an 8-henry inductor and a 5-mho conductance (in parallel) between node 2 and the reference. The two similar terms in Eq. (4-18) and Eq. (4-19) represent a 4-farad capacitor present mutually at nodes 1 and 2; the circuit is completed by connecting this capacitor between the two nodes. The constant term on the

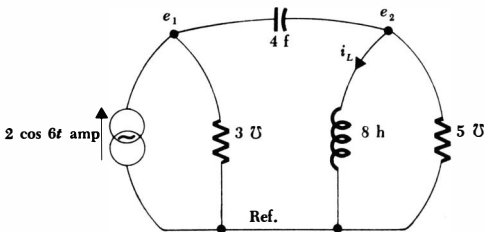

Fig. 4-25 The exact dual of the circuit of Fig. 4-24.

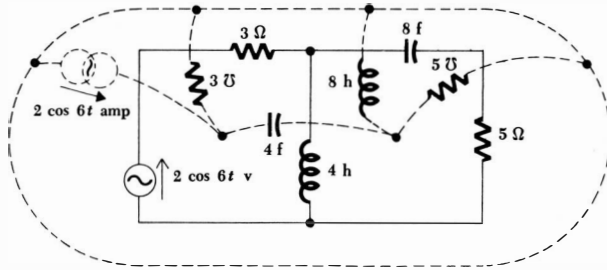

Fig. 4-26 The dual of the circuit of Fig. 4-24 is constructed directly from the circuit diagram.

right side of Eq. (4-19) is the value of the inductor current at $t = 0$; thus, $i_L(0) = 10$. The dual circuit is shown in Fig. 4-25; since the two sets of equations are numerically identical, the circuits are exact duals.

Dual circuits may be obtained more readily than by the above method, for the equations need not be written. In order to construct the dual of a given circuit, we think of the circuit in terms of its mesh equations. With each mesh we must associate a nonreference node, and, in addition, we must supply the reference node. On a diagram of the given circuit we therefore place a node in the center of each mesh and supply the reference node as a line below the diagram or a loop enclosing the diagram. Each element which appears jointly in two meshes is a mutual element and gives rise to identical terms, except for sign, in the two corresponding mesh equations. It must be replaced by an element which supplies the dual term in the two corresponding nodal equations. This dual element must therefore be connected directly between the two nonreference nodes which are within the meshes in which the given mutual element appears. The nature of the dual element itself is easily determined; the mathematical form of the equations will be the same only if inductance is replaced by capacitance, capacitance by inductance, and resistance by conductance. Thus, the 4-henry inductor which is common to meshes 1 and 2 in the circuit of Fig. 4-24 appears as a 4-farad capacitor connected directly between nodes 1 and 2 in the dual circuit.

Elements which appear only in one mesh must have duals which appear between the corresponding node and the reference node. Referring again to Fig. 4-24, the voltage source $2 \cos 6t$ v appears only in mesh 1; its dual is a current source $2 \cos 6t$ amp which is connected only to node 1 and the reference node. Since the voltage source is clockwise sensed, the current source must be into-the-nonreference-node-sensed. Finally, provision must be made for the dual of the initial voltage present across the 8-farad capacitor in the given circuit. The equations have shown us that the dual of this initial voltage across the capacitor is an initial current through the inductor in the dual circuit; the numerical values are the same, and the correct sign of the initial current may be determined most readily by considering both the initial voltage in the given circuit and the

initial current in the dual circuit as sources. Thus, if e_c in the given circuit is treated as a source, it would appear as $-e_c$ on the right side of the mesh equation; in the dual circuit, treating the current i_L as a source would yield a term $-i_L$ on the right side of the nodal equation. Since each has the same sign when treated as a source, then, if $e_c(0) = 10$, $i_L(0)$ must also be 10.

The circuit of Fig. 4-24 is repeated in Fig. 4-26, and its exact dual is constructed on the circuit diagram itself by merely drawing the dual of each given element between the two nodes which are centered in the two meshes which are common to the given element. A reference node which surrounds the given circuit may be helpful. After the dual circuit is redrawn in more standard form, it appears as shown in Fig. 4-25.

An additional example of the construction of a dual circuit is shown in Fig. 4-27a and b. Since no particular element values are specified, these two circuits are duals, but not necessarily exact duals. The original circuit may be recovered from the dual by placing a node in the center of each of the five meshes of Fig. 4-27b and proceeding as before.

The concept of duality may also be carried over into the language by which we describe circuit analysis or operation. One example of this was discussed previously in Sec. 4-4, and the duals of several words appeared there. Most of these pairs are obvious; whenever there is any question as to the dual of a word or phrase, the dual circuit may always be drawn or visualized and then described in similar language. For example, if we are given a voltage source in series with a capacitor, we might wish to make the important statement, "the voltage source causes a current to flow through the capacitor"; the dual statement is, "the current source causes a voltage to exist across the inductor." The

Fig. 4-27 (a) The dual (in light lines) of a given circuit (in heavy lines) is constructed around the given circuit. (b) The dual circuit is drawn in more conventional form.

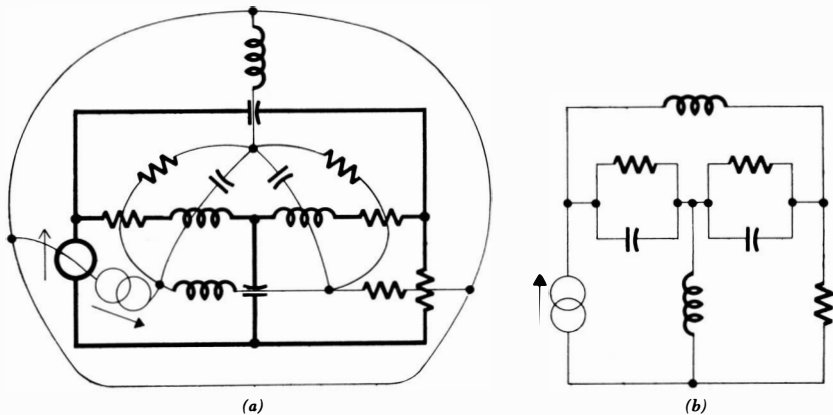

dual of a less carefully worded statement, such as, "the current goes round and round the series circuit," often requires a little inventiveness.⁴

Practice in using dual language can be obtained by reading Thévenin's theorem in this sense; Norton's theorem should result.

We have spoken of dual elements, dual language, and dual circuits. What about a dual *network*? Consider a resistor R and an inductor L in series. The dual of this two-terminal network exists and is most readily obtained by connecting some ideal source to the given network. The dual circuit is then obtained as the dual source in parallel with a conductance G , $G = R$, and a capacitance C , $C = L$. We consider the dual network as the two-terminal network that is connected to the dual source; it is thus a pair of terminals between which G and C are connected in parallel.

Before leaving the definition of duality, it should be pointed out that duality is defined on the basis of mesh and nodal equations. Since nonplanar circuits cannot be described by a system of mesh equations, a circuit which cannot be drawn in planar form does not possess a dual.

We shall use duality principally to reduce the work which we must do to analyze the simple standard circuits. After we have analyzed the series RL circuit, then the parallel RC circuit requires less attention, not because it is less important, but because the analysis of the dual network is already known. Since the analysis of some complicated circuit is not apt to be well known, duality will usually not provide us with any quick solution.

Drill Problems

4-15 (a) How many nodes are there in the circuit which is the dual of a two-mesh circuit? (b) If a given four-mesh circuit contains four resistors, three capacitors, and two inductors, how many inductors will be present in the dual circuit? (c) What is the ratio of the power delivered to a certain resistive element in a given circuit to the power delivered to the dual of that element in the circuit which is the exact dual of the given circuit?

Ans. 3; 1; 3

⁴Someone has suggested, "the voltage is across all over the parallel circuit."

Fig. 4-28 See Drill Prob. 4-16.

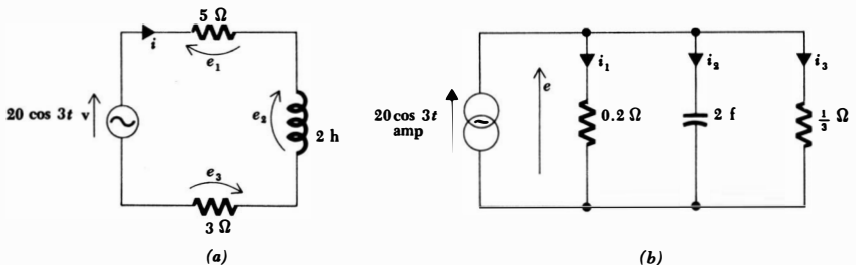

4-16 Write the mesh equation for the circuit of Fig. 4-28*a* and show, by direct substitution, that $i = 1.6 \cos 3t + 1.2 \sin 3t$ amp is a solution. Then use the duality principle for the circuit of Fig. 4-28*b* to determine: (a) i_1 ; (b) i_2 ; (c) i_3 .

Ans. $7.2 \cos 3t - 9.6 \sin 3t$ amp; $8 \cos 3t + 6 \sin 3t$ amp; $4.8 \cos 3t + 3.6 \sin 3t$ amp

4-7 LINEARITY AND SUPERPOSITION AGAIN

In the previous chapter we learned that the principle of superposition is a necessary consequence of the linear nature of the resistive circuits which we were analyzing. The resistive circuits are linear because the voltage-current relationship for the resistor is linear.

We now wish to show that the benefits of linearity apply to *RLC* circuits as well. In accordance with our previous definition of a linear circuit, these circuits are also linear because the voltage-current relationships for the inductor and capacitor are linear relationships. This is easily demonstrated. For the inductor we have

$$e = L \frac{di}{dt}$$

Multiplication of the current by some constant K leads to a voltage which is also greater by a factor K ; the voltage-current relationship is therefore linear, and the inductor is a linear element. The defining expression for the capacitor,

$$i = C \frac{de}{dt}$$

shows that the capacitor is also a linear circuit element. Finally, a circuit composed of ideal sources and linear resistors, inductors, and capacitors is a linear circuit.

In this linear circuit the response is again proportional to the forcing function. The proof of this statement is accomplished by first writing a general system of integrodifferential equations, say in terms of node voltages. Let us place all the terms having the form of Ge , $C de/dt$, and $(1/L) \int e dt$ on the left side of each equation and keep the source currents on the right side. As a simple example, one of the equations might have the form

$$Ge + C \frac{de}{dt} + \frac{1}{L} \int e dt = i_s \quad (4-20)$$

If every source is now increased by a factor K , then the right side of each equation is greater by the factor K . But each term on the left is a linear term involving some node voltage, and the solution of this new system of equations must therefore consist of a set of node voltages, each of which is greater than its previous value by the factor K .

One point still needs clarification, however. In writing a general system of nodal or mesh equations, integrals of the form $(1/L) \int e \, dt$ or $(1/C) \int i \, dt$ must be accompanied by a constant of integration. In writing Eq. (4-20), this constant is understood, in accordance with the discussion in Sec. 4-3. Let us now show this constant explicitly:

$$Ge + C \frac{de}{dt} + \frac{1}{L} \int_{t_0}^t e \, dt + i_L(t_0) = i_s \quad (4-21)$$

If we now replace i_s by Ki_s , it is apparent that the new value for e is not Ke . If the source and response are still to be proportional, then the *initial inductor current must be treated as a source current* and increased also by a factor of K . We shall therefore understand that the initial values of inductor currents (or capacitor voltages, in the case of mesh equations) appear on the right side of the equations and are treated as sources. This treatment of initial values as equivalent sources is elaborated upon later, particularly in Chap. 7.

The principle of proportionality between source and response is thus extensible to the general RLC circuit. Let us now show that the principle of superposition is also applicable. The proof must be phrased in terms of a system of general mesh or nodal equations, but we may illustrate the method by considering a single equation of the form of Eq. (4-21). If each source and response is considered to be the sum of two parts, Eq. (4-21) may be written

$$G(e_a + e_b) + C \frac{d}{dt}(e_a + e_b) + \frac{1}{L} \int_{t_0}^t (e_a + e_b) \, dt \\ = (i_{sa} + i_{sb}) - [i_{La}(t_0) + i_{Lb}(t_0)]$$

The linear nature of each of the left-hand terms enables us to express each term as the sum of a term involving e_a and one involving e_b :

$$Ge_a + Ge_b + C \frac{de_a}{dt} + C \frac{de_b}{dt} + \frac{1}{L} \int_{t_0}^t e_a \, dt + \frac{1}{L} \int_{t_0}^t e_b \, dt \\ = i_{sa} - i_{La}(t_0) + i_{sb} - i_{Lb}(t_0)$$

This equation, however, may be obtained by adding two equations of the form of Eq. (4-21), one with a subscripts for experiment a , and the other carrying b subscripts. If the sum of the two sets of sources is equal to some desired source, then the response to this desired source may be obtained by adding the responses produced by each source acting alone. In other words, the superposition principle is applicable to general RLC circuits. Again, it must be pointed out that initial inductor currents and capacitor voltages must be treated as sources in applying the superposition principle; each initial value must take its turn in being rendered inactive.

Before we can apply the superposition principle to RLC circuits, it is first necessary to develop methods of solving the equations describing these circuits when only one source is present. At this time we should feel convinced that a linear

circuit will possess a response whose amplitude is proportional to the amplitude of the source. We should be prepared to apply superposition later, considering an inductor current or capacitor voltage specified at $t = t_0$ as a source which must be killed when its turn comes.

4-8 THEVENIN'S AND NORTON'S THEOREMS

Since proving and learning to use Thévenin's and Norton's theorems, we have added the inductor and the capacitor to our collection of circuit elements, and we must consider the applicability of those two theorems to the more general circuits which may contain these two new energy-storage elements. We shall see that the theorems remain valid, even when energy is stored initially in any of the inductors and capacitors.

In the previous section we reached the conclusion that initial inductor currents and capacitor voltages may be accounted for by including appropriately connected ideal current sources and voltage sources in the circuit to represent these initial conditions. The superposition principle then applies without restraint.

Now let us recall our discussion of Thévenin's and Norton's theorems from the third chapter. We first assumed that we were considering a general linear active circuit; any circuit containing linear inductors, capacitors, and resistors is also a linear circuit. We then visualized the circuit as being broken up into two networks A and B connected by a single pair of conductors; both A and B could be active networks. We used the superposition principle and Kirchhoff's laws to show that the A network, for example, could be replaced by a much simpler network which was equivalent to A , at least from the viewpoint of B . This Thévenin equivalent of A was obtained by killing all the generators in A , including the initial-condition generators, and then placing the inactive A network in series with an ideal voltage source whose voltage was equal to the open-circuit terminal voltage across A before it was rendered inactive. The Norton equivalent for the A network was obtained in a dual manner by killing all the sources in the A network and then placing the inactive A network in parallel with an ideal current source whose current was equal to the current which would flow in a short circuit across the terminals of A before it was killed.

Thus, linearity of the original circuit, the applicability of Kirchhoff's laws, and the superposition principle were the only prerequisites for the proof of Thévenin's and Norton's theorems. The general RLC circuit, however, conforms perfectly to these requirements. It follows, therefore, that all linear circuits which contain any combinations of ideal voltage sources and current sources and linear resistors, inductors, and capacitors may be analyzed with the use of these two theorems, if we wish. It is not necessary to repeat the theorems here, for they were previously stated in a manner that is equally applicable to the general RLC circuit.

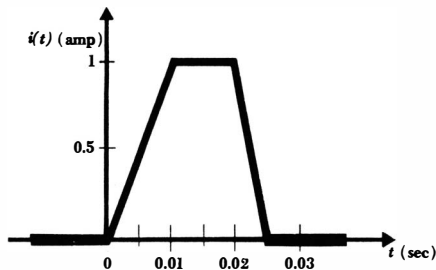

Fig. 4-29 See Prob. 3.

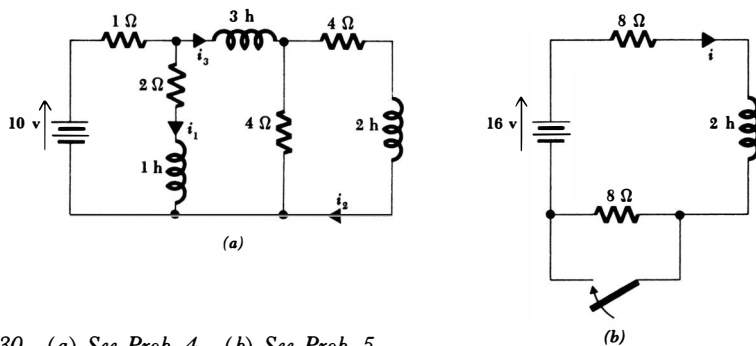

Fig. 4-30 (a) See Prob. 4. (b) See Prob. 5.

Problems

- 1 (a) The current through a certain 5-henry inductance increases linearly from zero to 1 amp in 0.01 sec and then decreases linearly to zero in 0.005 sec. Find the voltage across the inductance. Sketch the current and voltage on the same time axis. (b) A 20-mh inductance has no current flowing through it when a rectangular voltage pulse of 500- μ sec duration and 100-volt amplitude is suddenly applied to it. Find and sketch the resultant current flow.
- 2 For each part of Prob. 1, determine the time at which the energy stored in the inductance is a maximum and find this maximum energy.
- 3 The current through a 2-henry inductor is sketched as a function of time in Fig. 4-29. Make accurate labeled sketches of: (a) inductor voltage versus t ; (b) inductor power versus t ; (c) total stored energy versus t .
- 4 Find i_1 , i_2 , and i_3 in the circuit shown in Fig. 4.30a.
- 5 The circuit of Fig. 4-30b has been in the condition shown for a long time. Then the switch is suddenly closed. (a) Just before the switch closes, what is the value of i ? (b) Just after the switch closes, determine the value of i . (c) If the switch remains closed forever, what value does i finally assume?
- 6 Answer parts a, b, and c of Prob. 5 for the circuits of Fig. 4-31a and b.

- 7 (a) The voltage across a certain $0.5\text{-}\mu\text{f}$ capacitor increases linearly from zero to 100 volts in 10^{-3} sec, remains at 100 volts for 2×10^{-3} sec, and then decreases linearly to zero in 0.5×10^{-3} sec. Find the current through the capacitor and sketch the current and voltage waveforms on the same time axis. (b) A 400-pf capacitor has no initial voltage. A current of 2 ma is suddenly applied and maintained for 1 msec. Find and sketch the capacitor voltage.
- 8 For each part of Prob. 7, determine the time at which the energy stored in the capacitance is a maximum and find this maximum energy.
- 9 The voltage shown in Fig. 4-32 is impressed across a 5-farad capacitor. (a) Sketch the capacitor current as a function of time; use numerical scales on both axes. (b) At what instant is $w_C(t)$ a maximum? (c) What is $w_C(t)_{\text{max}}$?
- 10 Find e_1 , e_2 , and e_3 in the circuit shown in Fig. 4-33a.
- 11 The circuit of Fig. 4-33b has been in the condition shown for a very long time. The switch is then suddenly closed. (a) Just before the switch closes, what is the value of e ? (b) Just after the switch closes, what is the value of e ? (c) If the switch remains closed forever, what value does e finally assume?
- 12 Answer parts a, b, and c of Prob. 11 for the circuits of Fig. 4-34a and b.
- 13 A 0.2-farad capacitor and a 3-henry inductor are connected in series. Neither element contains any stored energy. A triangular current pulse is

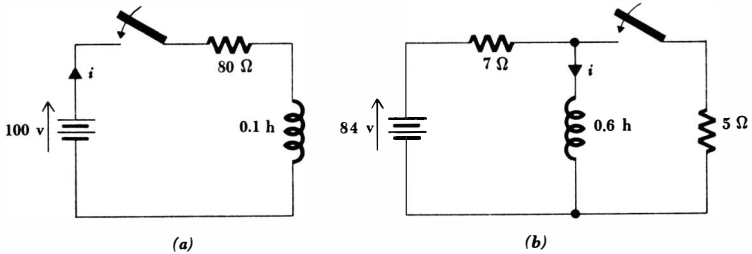

Fig. 4-31 See Prob. 6.

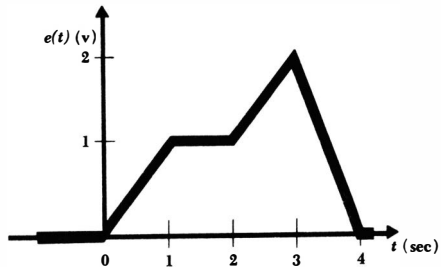

Fig. 4-32 See Prob. 9.

then applied by an ideal current source to the series combination. Assume a pulse which is zero for $t \leq 0$, rises linearly to 5 amp at $t = 1$ sec, and then decreases linearly to zero at $t = 2$ sec, remaining at zero thereafter. Sketch the current pulse, the inductor voltage, the capacitor voltage, and the voltage across the source as functions of time on the same axis.

- ◆14 An 8-henry inductor and a 2-farad capacitor are in series. A current $i = 5 \sin \frac{1}{4}t$ amp flows through the series combination. (a) Find the voltage across the inductance at any time t . (b) Find the voltage across the capacitor at any time t if the stored energy is zero at $t = 2\pi$ sec. (c) What is the voltage across the series combination?
- 15 (a) A helical coil (often called a "solenoid") has a length of 6 in., a diameter of 1 in., and contains 20 turns per inch. Find the inductance if the coil is air-filled. (b) Assume that the turns of wire are touching, but that each wire has an insulating coating which is 0.01 in. thick. The wire is annealed copper and has a circular cross section. Find the total resistance of the coil.
- 16 (a) A capacitor is constructed of two sheets of metal foil, each 1 by 80 in., separated by an insulating layer which is 0.005 in. thick. The permittivity of the insulating material is five times larger than that for air (i.e., the "dielectric constant" is 5). Find the capacitance. (b) Recalling from Chap. 2, Prob. 4, that $R = \rho d/A$, find the resistance present between the two sheets. The resistivity ρ of the insulating material is 2×10^{10} ohm-m.

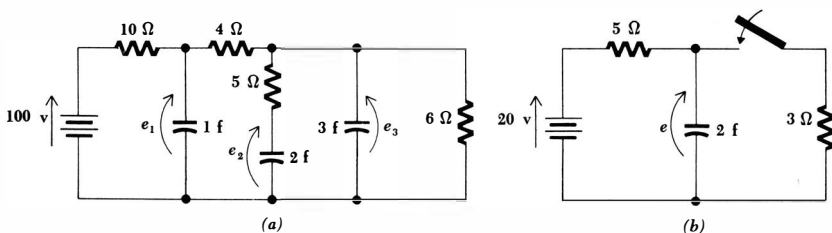
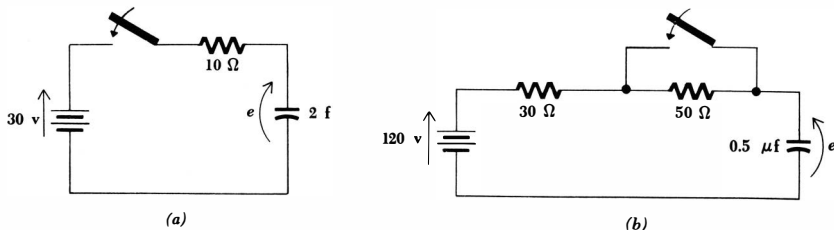

Fig. 4-33 (a) See Prob. 10. (b) See Prob. 11.

Fig. 4-34 See Prob. 12.



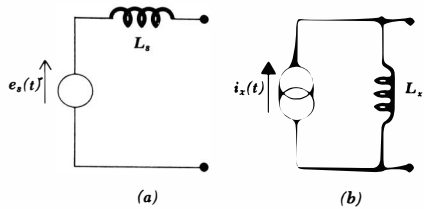

Fig. 4-35 See Prob. 17a.

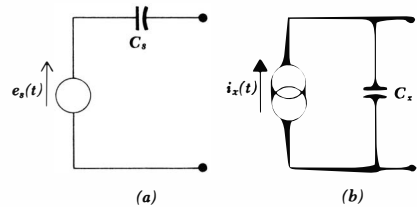

Fig. 4-36 See Prob. 17b.

- (c) Using an identical second insulating layer, the sheets are then rolled up to form the completed capacitor. Show that this doubles the capacitance and halves the resistance.
- ◆17 (a) A general inductive voltage source is shown in Fig. 4-35a. The equivalent current source is sketched in Fig. 4-35b. By finding the open-circuit voltage and short-circuit current for each source, determine L_x and $i_x(t)$ in terms of L_s and $e_s(t)$. (b) Repeat for the capacitive sources of Fig. 4-36.
- 18 (a) Use the definition of current $i = dq/dt$ to show that the charge on one of the plates of a capacitor is equal to the product of the capacitance and the voltage across the capacitor. It may be assumed that the voltage is zero when the charge is zero. (b) In what other forms, involving charge, might the expression for the energy stored in a capacitor be written?
- 19 Given a source current $i_s = 10 \cos 6t$ applied first to a 5-ohm resistor, then to a 3-henry inductor, and finally to a 2-farad capacitor, determine the voltage across the resistor at $t = 0$, the voltage across the inductor at $t = 0$, and show that the voltage across the capacitor cannot be found at $t = 0$ unless some additional information is specified. What form may this information take?
- ◆20 Find the voltage e_x across the 3-henry inductor in the circuit of Fig. 4-37a.
- ◆21 Find the current i_x through the 4-farad capacitor in the circuit of Fig. 4-37b.
- 22 Write the single integrodifferential equation, in terms of the source voltage and the element values, by which the current i may be obtained in the circuit of Fig. 4-38.
- 23 (a) In the circuit of Fig. 4-39a, it is known that $i_L = 10e^{-0.2t}$. Find i_R . (b) For the same circuit, let $i_R = 5 \sin 200t$ and find i_L . Assume that no energy is stored in the inductor at $t = 0$.
- ◆24 In the circuit shown in Fig. 4-39b, assume that $e_R = 6(1 - e^{-0.3t})$ and find $e_s(t)$.

- 25 In the circuit shown in Fig. 4-40a, it is known that $e_L(t) = -2 \sin 6t$, $i(t) = \cos 6t$, $e_C(t) = 2 \sin 6t$, and $e_C = 0$ at $t = 0$. (a) Find the values of L and C . (b) Find the expression for $e_R(t)$. (c) Find the expression for $e_s(t)$.
- 26 Write the mesh equations for the circuit of Fig. 4-40b. Where possible, reduce series and parallel components to a single equivalent expression.
- ◆27 Write the set of mesh equations for the circuit shown in Fig. 4-41.
- 28 After transforming the voltage sources to current sources, write the set of nodal equations for the circuit of Fig. 4-41. Choose the bottom node as the reference node.
- ◆29 An expression for voltage division between two series resistors was derived in Chap. 2. Determine the corresponding results for inductances and capacitances by finding: (a) $e_2(t)/e_s(t)$ for the circuit of Fig. 4-42a; (b) $e_2(t)/e_s(t)$ for Fig. 4-42b.

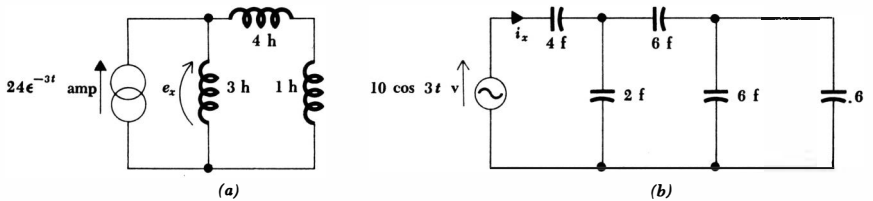

Fig. 4-37 (a) See Prob. 20. (b) See Prob. 21.

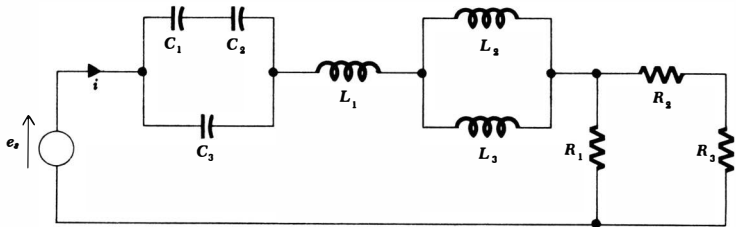
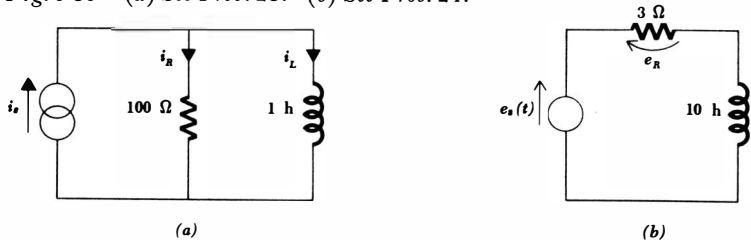

Fig. 4-38 See Prob. 22.

Fig. 4-39 (a) See Prob. 23. (b) See Prob. 24.



- ◆30 Determine expressions for current division between two parallel inductors and capacitors by finding: (a) $i_2(t)/i_s(t)$ for the circuit of Fig. 4-43a; (b) $i_2(t)/i_s(t)$ for Fig. 4-43b.
- ◆31 Construct the duals of the networks shown in Fig. 4-44a and b.
- 32 Construct the exact duals of the networks shown in Fig. 4-45a and b.
- 33 The circuit shown in Fig. 4-46a contains a switch which closes at $t = 0$. Construct the exact dual of this circuit and include the switch by considering it as a resistor which suddenly changes value at $t = 0$.
- 34 (a) In the circuit shown in Fig. 4-46b, replace the network to the left of $a-b$ by its Thévenin equivalent. (b) Construct the exact dual of the resultant circuit. (c) Construct the dual of the circuit of Fig. 4-46b. (d) Apply

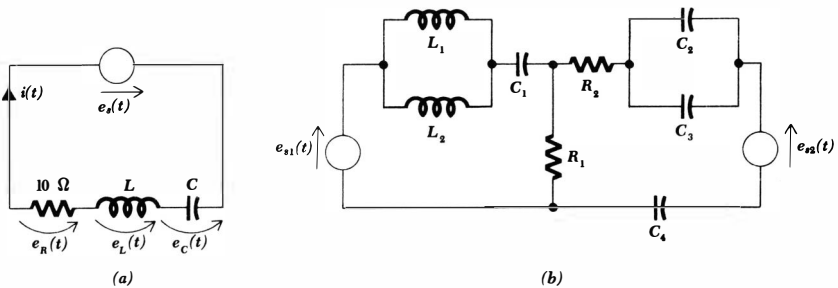

Fig. 4-40 (a) See Prob. 25. (b) See Prob. 26.

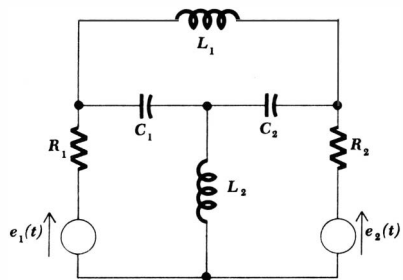

Fig. 4-41 See Probs. 27 and 28.

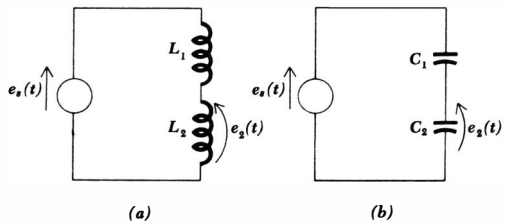

Fig. 4-42 See Prob. 29.

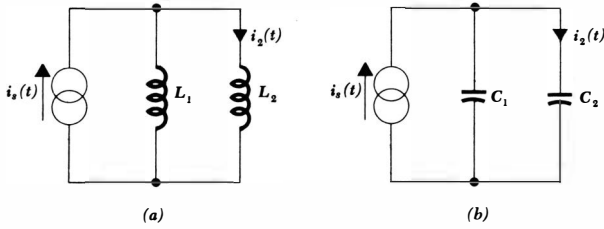

Fig. 4-43 See Prob. 30.

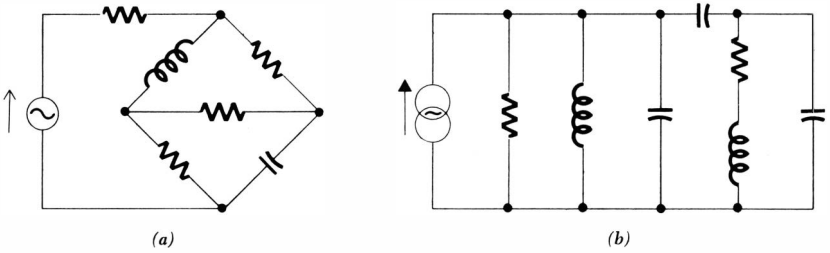

Fig. 4-44 See Prob. 31.

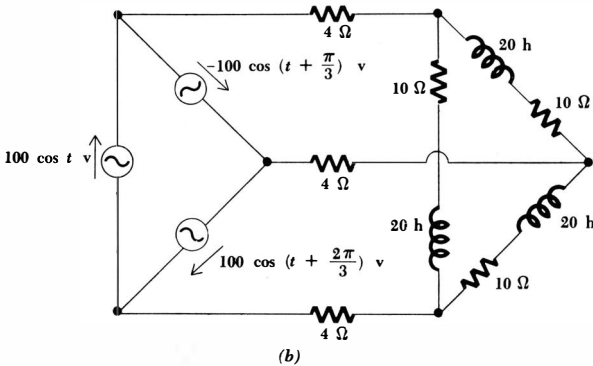
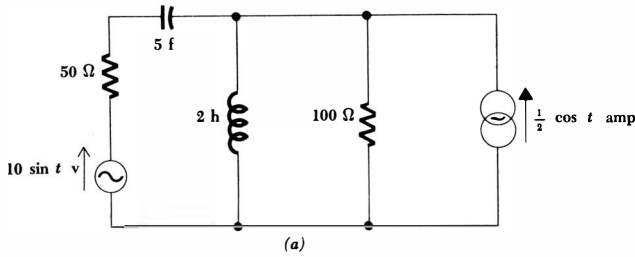

Fig. 4-45 See Prob. 32.

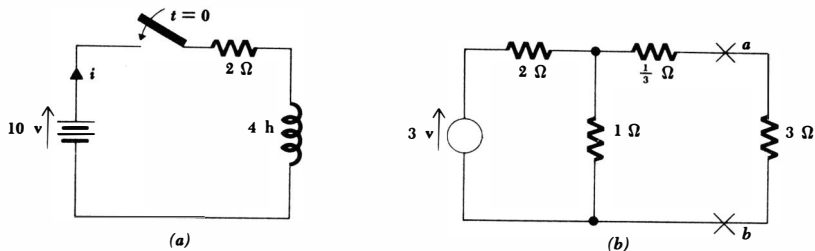

Fig. 4-46 (a) See Prob. 33. (b) See Prob. 34.

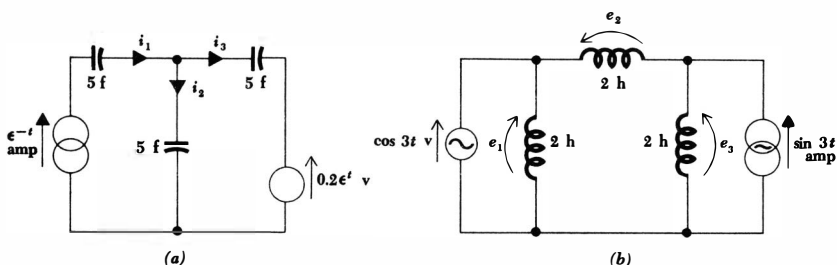

Fig. 4-47 (a) See Probs. 37 and 38. (b) See Probs. 39 and 40.

Norton's theorem to the portion of the dual circuit to the "left" of $a-b$. (e) Compare the circuits of parts b and d.

- ◆35 A circuit or network is said to be a *self-dual* if the circuit or network and its dual are the same. (a) Find several source-free two-element networks which are self-duals. Can element values be chosen to provide exact self-duals? (b) Construct a self-dual which contains all the five different elements (i_s , e_s , R , L , C). The circuit may contain more than five elements, however. Can the circuit be an exact self-dual?
- 36 Prove that the dual of the dual of any given circuit is the given circuit; illustrate by a reasonably simple, reasonably complicated example.
- ◆37 Use the superposition principle to find i_1 , i_2 , and i_3 in the circuit of Fig. 4-47a.
- 38 Rework Prob. 37 by transforming the general capacitive voltage source into a current source.
- ◆39 Use the superposition principle to find e_1 , e_2 , and e_3 in the circuit shown in Fig. 4-47b.
- 40 Rework Prob. 39 by transforming the general inductive current source into a voltage source.

Chapter 5 Source-free *RL* and *RC* Circuits

5-1 INTRODUCTION

In the previous chapter we wrote the equations which governed the response of a number of circuits containing both inductance and capacitance, but we did not solve these equations. At this time we are ready to proceed with the solution for the simpler circuits. We shall restrict our attention to certain circuits which contain only resistors and inductors or only resistors and capacitors, and which contain no sources. We shall, however, allow the presence of energy which is stored in the inductors or capacitors, for without such energy every response would be zero.

Although the circuits which we are about to consider have a very elementary appearance, they are also of practical importance. They find use as coupling networks in vacuum-tube and transistor amplifiers, as compensating networks in automatic control systems, as equalizing networks in communications channels, and in many other ways. A familiarity with these simple circuits will enable us to predict the accuracy with which the output of an amplifier can follow an input which is changing rapidly with time or to predict how quickly the speed of a motor will change in response to a change in its field current. Our knowledge of the performance of the simple *RL* and *RC* circuits will also enable us to suggest modifications to the amplifier or motor in order to obtain a more desirable response.

The analysis of such circuits is dependent upon the formulation and solution of the integrodifferential equations which characterize the circuits. We shall call the special type of equation we obtain a homogeneous linear differential equation, which is simply a differential equation in which every term is of the first degree in the dependent variable and its derivatives. A *solution* is obtained when we have found an expression for the dependent variable, as a function of time, which satisfies the differential equation and also satisfies the prescribed energy distribution in the inductors or capacitors at a prescribed instant of time, usually $t = 0$.

The solution of the differential equation represents a response of the circuit, and it is known by many names. Since this response depends upon the general “nature” of the circuit (the types of elements, their sizes, the interconnection of the elements), it is often called a *natural response*. It is also obvious that any real circuit we construct cannot store energy forever; the resistances necessarily associated with inductors and capacitors will eventually convert all stored energy into heat. The response must eventually die out, and it is therefore referred to as the *transient response*. Finally, we must also be familiar with the mathematician’s contribution to the nomenclature; he calls the solution of a homogeneous linear differential equation a *complementary function*. When we consider sources acting on a circuit, part of the response will partake of the nature of the particular source used; this part of the response will be “complemented” by the complementary response produced in the source-free circuit, and their sum will be the complete response. The source-free response may be called the natural response, the transient response, or the complementary function, but because of its more descriptive nature, we shall most often call it the natural response.

We shall consider several different methods of solving these differential equations. This mathematics, however, is not circuit analysis. Our greatest interest lies in the solutions themselves, their meaning, and their interpretation, and we shall try to become sufficiently familiar with the form of the response that we are able to write down answers for new circuits by just plain thinking. Although complicated analytical methods are needed when simpler methods fail, an engineer must always remember that these complex techniques are only tools with which meaningful, informative answers may be obtained; they do not constitute engineering in themselves.

5-2 THE SIMPLE RL CIRCUIT

We shall begin our study of transient analysis by considering the simple series *RL* circuit shown in Fig. 5-1. Let us designate the time-varying current as $i(t)$, and we shall let the value of $i(t)$ at $t = 0$ be prescribed as I_0 . We therefore have

$$e_R + e_L = iR + L \frac{di}{dt} = 0$$

$$\text{or} \quad \frac{di}{dt} + \frac{R}{L} i = 0 \quad (5-1)$$

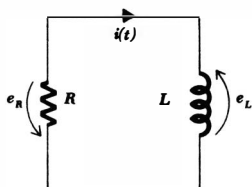

Fig. 5-1 A series RL circuit for which $i(t)$ is to be determined, subject to the initial condition that $i(0) = I_0$.

and we must determine an expression for $i(t)$ which satisfies this equation and also has the assumed value of $i(t)$ at $t = 0$. The solution may be obtained by several different methods.

One very direct method of solving differential equations consists of writing the equation in such a way that the variables are separated and then integrating each side of the equation. The variables in Eq. (5-1) are i and t , and it is apparent that the equation may be multiplied by dt , divided by i , and arranged with the variables separated,

$$\frac{di}{i} = -\frac{R}{L} dt \quad (5-2)$$

Since the current is I_0 at $t = 0$ and $i(t)$ at time t , we may equate the two definite integrals which are obtained by integrating each side between the corresponding limits,

$$\int_{I_0}^{i(t)} \frac{di}{i} = \int_0^t -\frac{R}{L} dt$$

and, therefore,

$$\ln i \Big|_{I_0}^t = -\frac{R}{L} t \Big|_0^t$$

$$\text{or} \quad \ln i - \ln I_0 = -\frac{R}{L} t$$

Therefore,

$$i(t) = I_0 e^{-Rt/L} \quad (5-3)$$

We check our solution by first showing that substitution of Eq. (5-3) into Eq. (5-1) yields the identity $0 \equiv 0$ and then showing that substitution of $t = 0$ into Eq. (5-3) produces $i(0) = I_0$. Both steps are necessary; the solution must satisfy the differential equation which characterizes the circuit, and it must also satisfy the initial condition, or the response at zero time.

The solution may also be obtained by a slight variation of the method described above. After separating the variables, we may obtain the *indefinite* integral of each side of Eq. (5-2) if we also include a constant of integration. Thus,

$$\int \frac{di}{i} = -\int \frac{R}{L} dt + K$$

and integration gives us

$$\ln i = -\frac{R}{L} t + K \quad (5-4)$$

The constant K cannot be evaluated by substitution of Eq. (5-4) into the original differential equation (5-1); the identity $0 \equiv 0$ will result, because Eq. (5-4) is a solution of Eq. (5-1) for any value of K . The constant of integration must be

selected to satisfy the initial condition $i(0) = I_0$. Thus, at $t = 0$, Eq. (5-4) becomes

$$\ln I_0 = K$$

and we use this value for K in Eq. (5-4) to obtain the desired response

$$\ln i = -\frac{R}{L}t + \ln I_0$$

or
$$i(t) = I_0 e^{-Rt/L}$$

as before.

Either of the methods above can be used only when the variables can be separated, and this is only occasionally possible. In the remaining cases we shall rely on a very powerful method, the success of which will depend upon our intuition or experience. We shall simply guess or assume a form for the solution and then test our assumptions, first by substitution into the differential equation and then by applying the given initial conditions. Since we cannot be expected to guess the exact numerical expression for the solution, we shall assume a solution containing several unknown constants and select the values for these constants in order to satisfy the differential equation and the initial conditions. Many of the differential equations encountered in circuit analysis have a solution which may be represented by the exponential function or by the sum of several exponential functions. Let us assume a solution of Eq. (5-1) in exponential form,

$$i(t) = A e^{s_1 t}$$

where A and s_1 are constants to be determined. After substituting this assumed solution into Eq. (5-1), we have

$$A s_1 e^{s_1 t} + \frac{R}{L} A e^{s_1 t} = 0$$

or
$$\left(s_1 + \frac{R}{L}\right) A e^{s_1 t} = 0$$

In order to satisfy this equation for all values of time, it is necessary that $A = 0$, $s_1 = -\infty$, or $s_1 = -R/L$. But if $A = 0$ or $s_1 = -\infty$, then every response is zero; neither can be a solution to our problem. Therefore, we must choose

$$s_1 = -\frac{R}{L}$$

and our assumed solution takes on the form

$$i(t) = A e^{-Rt/L}$$

The remaining constant must be evaluated by applying the initial condition $i = I_0$ at $t = 0$. Thus,

$$I_0 = A$$

and the final form of the assumed solution is

$$i(t) = I_0 e^{-Rt/L} \quad (5-5)$$

once again.

We shall not consider any other methods for solving Eq. (5-1), although a number of other techniques may be used. Watch for them in a study of differential equations.

Before we turn our attention to the interpretation of the response, let us check the power and energy relationships in this circuit. The power being dissipated in the resistor is

$$p_R = i^2 R = I_0^2 R e^{-2Rt/L}$$

and the total energy turned into heat in the resistor is found by integrating the instantaneous power from zero time to infinite time,

$$\begin{aligned} W_R &= \int_0^{\infty} p_R dt = I_0^2 R \int_0^{\infty} e^{-2Rt/L} dt \\ &= I_0^2 R \left(-\frac{L}{2R} \right) e^{-2Rt/L} \Big|_0^{\infty} = \frac{1}{2} L I_0^2 \end{aligned}$$

This is the result we expect, because the total energy stored initially in the coil is $\frac{1}{2} L I_0^2$, and there is no energy stored in the coil at infinite time. All the initial energy is accounted for by dissipation in the resistor.

Drill Problems

5-1 Each circuit shown in Fig. 5-2 has been in the condition shown for an extremely long time. At $t = 0$, the several switches are closed or opened as indicated. The single-pole double-throw switches appearing in *b* and *c* are drawn to indicate that they close one circuit before opening the other. They are called "make before break." After reviewing the characteristics of an inductor, as summarized on page 113, determine $i(0)$ in each circuit.

Ans. 10 amp; 4 amp; 6.25 amp

5-2 A 100-ohm resistor and a 5-henry inductor are in series. At $t = 0$ an energy of 160 joules is present in the coil. Find the magnitude of the current at: (a) $t = 0$; (b) $t = 0.1$ sec; (c) $t = 1$ sec.

Ans. 0 amp; 1.08 amp; 8.0 amp

5-3 For the circuit described in Drill Prob. 5-2, find the time at which the energy in the coil is the following percentage of the initial energy: (a) 50 per cent; (b) 10 per cent; (c) 1 per cent.

Ans. 0.115 sec; 0.0173 sec; 0.0575 sec

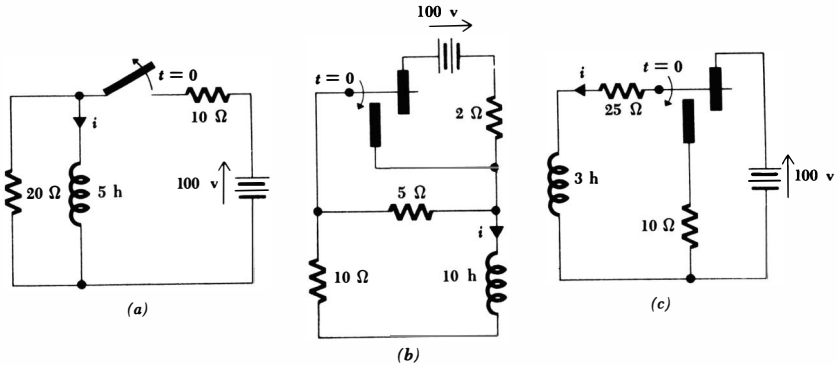

Fig. 5-2 See Drill Prob. 5-1.

5-3 PROPERTIES OF THE EXPONENTIAL RESPONSE

Let us now consider the nature of the response in the series *RL* circuit. We found that the current is represented by

$$i(t) = I_0 e^{-Rt/L} \tag{5-6}$$

At zero time, the current is the assumed value I_0 , and as time increases, the current decreases and approaches zero. The shape of this decaying exponential is seen by a plot of $i(t)/I_0$ versus t , as shown in Fig. 5-3. Since the function we are plotting is $e^{-Rt/L}$, the curve will not change if R/L does not change. Thus, the same curve must be obtained for every series *RL* circuit having the same R/L or L/R ratio. Let us see how this ratio affects the shape of the curve.

If we double the ratio of L to R , then the exponent will be unchanged if t is also doubled. In other words, the original response will occur at a later time, and the new curve is obtained by moving each point on the original curve twice as far to the right. With this larger L/R ratio, the current takes longer to decay to any given fraction of its original value. We might have a tendency to say

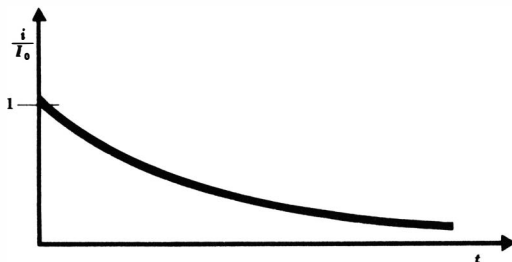

Fig. 5-3 A plot of $e^{-Rt/L}$ versus t .

that the "width" of the curve is doubled, or that the "width" is proportional to L/R . However, we should have to define our term "width," because each curve extends from $t = 0$ to ∞ . Instead, let us consider the time that would be required for the current to drop to zero *if it continued to drop at its initial rate*.

The initial rate of decay is found by evaluating the derivative at zero time,

$$\left. \frac{d}{dt} \frac{i}{I_0} \right|_{t=0} = -\frac{R}{L} \epsilon^{-Rt/L} \Big|_{t=0} = -\frac{R}{L}$$

Let us designate the value of time it takes for i/I_0 to drop from unity to zero, assuming a constant rate of decay, by the Greek letter τ (*tau*). Thus,

$$\frac{R}{L} \tau = 1$$

$$\text{or} \quad \tau = \frac{L}{R} \tag{5-7}$$

The ratio L/R has the physical dimensions of seconds since L and R have the respective dimensions $[ML^2Q^{-2}]$ and $[ML^2T^{-1}Q^{-2}]$. This result is confirmed by noting that the exponent $-Rt/L$ must be dimensionless. This value of time τ is called the *time constant*; it is shown in Fig. 5-4. It is apparent that the time constant of a series RL circuit may easily be found graphically from the response curve; it is only necessary to draw the tangent to the curve at $t = 0$ and determine the intercept of this tangent line with the time axis.

An equally important interpretation of the time constant τ is obtained by determining the value of $i(t)/I_0$ at $t = \tau$. We have

$$\frac{i(\tau)}{I_0} = \epsilon^{-1} = 0.368 \quad \text{or} \quad i(\tau) = 0.368I_0$$

Thus, in one time constant the response has dropped to 36.8 per cent of its initial value; the value of τ may also be determined graphically from this fact, as indicated by Fig. 5-5. It is convenient to measure the decay of the current at intervals of one time constant, and recourse to a slide rule or a table of neg-

Fig. 5-4 The time constant τ is L/R sec for a series RL circuit. It is the time required for the response curve to drop to zero if it decays at a constant rate which is equal to its initial rate of decay.

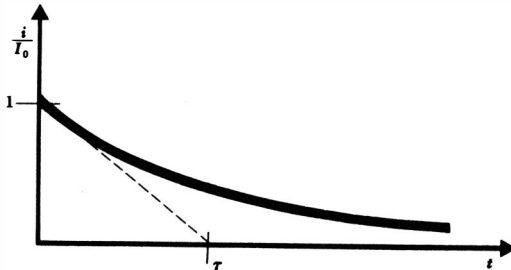

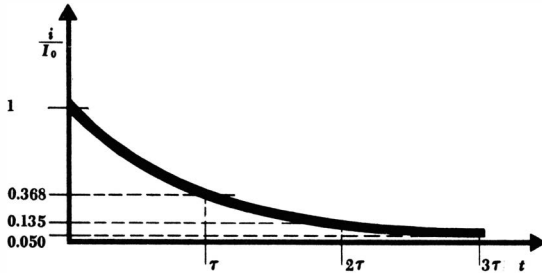

Fig. 5-5 The current in a series RL circuit is 36.8 per cent, 13.5 per cent, and 5 per cent of its initial value in τ , 2τ , and 3τ sec respectively.

ative exponentials shows that $i(t)/I_0$ is 0.368 at $t = \tau$, 0.135 at $t = 2\tau$, 0.0498 at $t = 3\tau$, 0.0183 at $t = 4\tau$, and 0.0067 at $t = 5\tau$. At some point three to five time constants after zero time, most of us would agree that the current is a negligible fraction of its former self.

Why does a larger value of the time constant L/R produce a response curve which decays more slowly? Let us consider the effect of each element. An increase in L allows a greater energy storage for the same initial current, and this larger energy requires a longer time to be dissipated in the resistor. We may also increase L/R by reducing R . In this case, the power flowing into the resistor is less for the same initial current; again, a greater time is required to dissipate the stored energy.

In terms of the time constant τ , the response of the series RL circuit may be written simply as

$$i(t) = I_0 e^{-t/\tau}$$

Drill Problem

5-4 Find the time constant of a series RL circuit in which: (a) the current at any instant is one-half of its value 1 sec ago; (b) the current is 2 amp at $t = t_1$ and is decreasing at the rate of 4 amp/sec; (c) the stored energy is 2 joules at $t = t_1$ and is decreasing at the rate of 4 joules/sec.

Ans. 0.5 sec; 1 sec; 1.443 sec

5-4 A MORE GENERAL RL CIRCUIT

It is not difficult to extend the results obtained for the series RL circuit to a circuit containing any number of resistors and one inductor. We fix our attention on the two terminals of the coil and determine the equivalent resistance across these terminals. The circuit is thus reduced to the simple series case. As an example, consider the circuit shown in Fig. 5-6. The equivalent resistance which the coil faces is

$$R_{eq} = R_3 + R_4 + \frac{R_1 R_2}{R_1 + R_2}$$

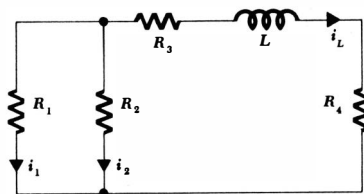

Fig. 5-6 A source-free circuit containing one inductor and several resistances.

and the time constant is therefore

$$\tau = \frac{L}{R_{eq}}$$

The inductor current i_L is

$$i_L = i_L(0)\epsilon^{-t/\tau} \quad (5-8)$$

and Eq. (5-8) represents what we might call the basic solution to the problem. It is quite possible that some current or voltage other than i_L is needed, such as the current i_2 in R_2 . We can always apply Kirchhoff's laws and Ohm's law to the resistive portion of the circuit without any difficulty, but current division provides the quickest answer in this circuit,

$$i_2 = -\frac{R_1}{R_1 + R_2} i_L(0)\epsilon^{-t/\tau}$$

It may also happen that we know the initial value of some current other than the inductor current. Since the current in a resistor may change instantaneously, we shall indicate the initial value *after* any change that might have occurred at $t = 0$ by use of the symbol 0^+ . Thus, if we are given the initial value of i_1 as $i_1(0^+)$, then it is apparent that the initial value of i_2 is

$$i_2(0^+) = i_1(0^+) \frac{R_1}{R_2}$$

From these values, we obtain the necessary initial value of $i_L(0)$ [or $i_L(0^-)$ or $i_L(0^+)$],

$$i_L(0) = -[i_1(0^+) + i_2(0^+)] = -\frac{R_1 + R_2}{R_2} i_1(0^+)$$

and the expression for i_2 becomes

$$i_2 = i_1(0^+) \frac{R_1}{R_2} \epsilon^{-t/\tau}$$

Let us see if we can obtain this last expression more directly. Since the inductor current decays exponentially as $\epsilon^{-t/\tau}$, then every current throughout the circuit must follow the same functional behavior. This is made clear by considering the inductor current as a source current which is being applied to a resistive net-

153 Source-free RL and RC Circuits

work. Every current and voltage in the resistive network must have the same time dependence. Using these ideas, we therefore express i_2 as

$$\dot{i}_2 = A\epsilon^{-t/\tau}$$

where

$$\tau = \frac{L}{R_{eq}}$$

and A must be determined from a knowledge of the initial value of i_2 . Since $i_1(0^+)$ is known, then the voltage across R_1 and R_2 is known, and

$$i_2(0^+) = i_1(0^+) \frac{R_1}{R_2}$$

Therefore,

$$i_2 = i_1(0^+) \frac{R_1}{R_2} \epsilon^{-t/\tau}$$

A similar sequence of steps will provide a rapid solution to a large number of problems. We first recognize the time dependence of the response as an exponential decay, determine the appropriate time constant by combining resistances, write the solution with an unknown amplitude, and then determine the amplitude from a given initial condition.

This same technique is also applicable to a circuit which contains one resistor and any number of inductors, although it will be necessary to consider one exceptional case. The exception arises because of the fact that a circuit containing more than one inductor may have an initial energy storage assigned to *each* inductance, subject, of course, to the requirements of Kirchhoff's current law. Consider, for example, the circuit illustrated in Fig. 5-7. Let us assign initial values to both i_1 and i_2 ,

$$i_1(0) = 1 \quad i_2(0) = 2$$

Thus,

$$i(0^+) = 3$$

and since the time constant is obviously $1/3$, we have no trouble in writing the correct expression for i ,

$$i(t) = 3\epsilon^{-3t} \tag{5-9}$$

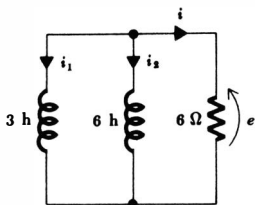

Fig. 5-7 A circuit having a closed path in which no resistance is present. This condition requires careful analysis.

There is a pitfall awaiting us when we attempt to find i_1 or i_2 too hurriedly, however. Should we use the known initial values and the known time constant to write

$$i_1(t) \stackrel{?}{=} 1\epsilon^{-3t} \quad (5-10)$$

$$i_2(t) \stackrel{?}{=} 2\epsilon^{-3t} \quad (5-11)$$

or should we try to extend the division of current in parallel resistors to the case of parallel inductors, yielding

$$i_1(t) \stackrel{?}{=} 2\epsilon^{-3t} \quad (5-12)$$

$$i_2(t) \stackrel{?}{=} 1\epsilon^{-3t} \quad (5-13)$$

Since the latter set, Eqs. (5-12) and (5-13), does not satisfy the given initial conditions, we throw it out immediately and conclude that current division between parallel inductors must be treated cautiously. However, the former set of equations is wrong also. This is easily shown by energy considerations. Equation (5-10) implies that the 3-henry inductor initially contains 1.5 joules of energy and that this energy all leaves this inductor; Eq. (5-11) states that the energy of the 6-henry inductor decreases from 12 joules to zero. Thus 13.5 joules has disappeared. But the resistor current, as given by Eq. (5-9), may be used to calculate the total energy dissipated in the 6-ohm resistor; the result is only 9 joules. Since the current in the resistor is known to be correct, some energy must remain in the two coils. Thus, a direct current may continue to flow in the closed path consisting of the two coils; there will be no voltage across either coil and no power delivered to the resistor. The current flows forever in this zero-resistance path.

Our trouble with Eqs. (5-10) and (5-11) can therefore be traced to the assumption of an exponential decay to zero. We must expect each of the inductor currents to be the sum of a constant and an exponential. The correct expressions are best found by taking several simple steps. The voltage across the resistor is

$$e = 6i = 18\epsilon^{-3t}$$

and i_1 is determined by integrating,

$$i_1 = \frac{1}{3} \int -18\epsilon^{-3t} dt + K$$

$$\text{or} \quad i_1 = 2\epsilon^{-3t} + K$$

The value of the integration constant is found by applying the initial condition

$$1 = 2 + K$$

and, therefore,

$$i_1 = -1 + 2\epsilon^{-3t}$$

Similarly,

$$i_2 = 1 + 1\epsilon^{-3t}$$

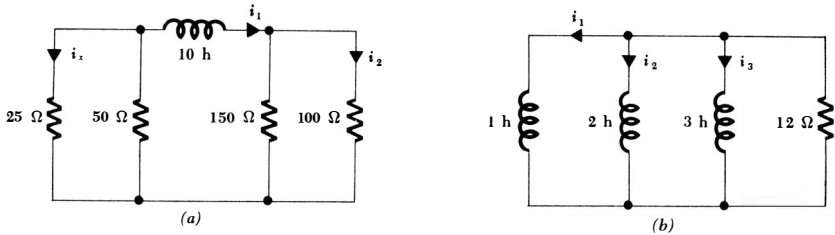

Fig. 5-8 (a) See Drill Prob. 5-5. (b) See Drill Prob. 5-6.

The sum of i_1 and i_2 gives the correct expression for $i(t)$, and a check of the energy relationships throughout the circuit is cheerfully left to the student.

A similar exceptional case may be found in *RC* circuits; it will be illustrated by the dual of the circuit above.

We have now considered the task of finding the natural response of circuits which contain only one inductor and any number of resistors or one resistor and any number of inductors. Some circuits containing two or more inductors and also two or more resistors may be simplified by resistance or inductance combination until the simplified circuits have only one inductance or one resistance. They may then be analyzed by the methods discussed above. The most general *RL* circuit will be considered in Sec. 5-7; the analysis is made more complicated because the response is composed of the sum of a number of negative exponentials.

Drill Problems

5-5 Find $i_x(t)$ at $t = 0.1$ sec for the circuit shown in Fig. 5-8a if: (a) $i_x(0^+) = 5$ amp; (b) $i_1(0) = 5$ amp; (c) $i_2(0^+) = 5$ amp.

Ans. 2.32 amp; -1.55 amp; -2.59 amp

5-6 For the circuit of Fig. 5-8b, find the value which i_1 approaches as t becomes infinite, given the initial conditions: (a) $i_1(0) = 12$ amp, $i_2(0) = 0$, $i_3(0) = 0$; (b) $i_1(0) = 12$ amp, $i_2(0) = 8$ amp, $i_3(0) = 2$ amp; (c) $i_1(0) = 12$ amp, $i_2(0) = 6$ amp, $i_3(0) = 4$ amp.

Ans. 0 amp; 0 amp; 5.45 amp

5-7 Find the time constant for each of the *RL* circuits shown in Fig. 5-9.

Ans. 0.24 sec; 0.4 sec; 1.05 sec

5-5 THE SIMPLE *RC* CIRCUIT

The series combination of a resistor and a capacitor has a greater practical importance than does the combination of a resistor and a coil. When an engineer has any freedom of choice between using a capacitor and using an inductor in the

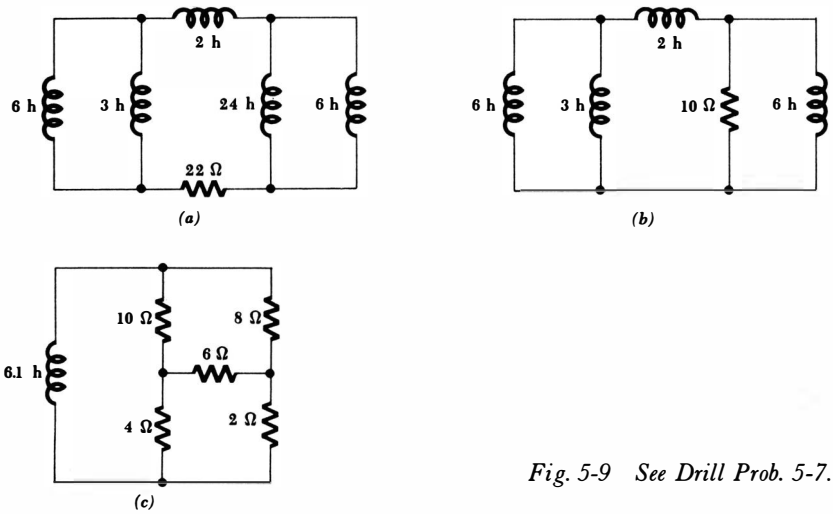

Fig. 5-9 See Drill Prob. 5-7.

coupling network of an electronic amplifier, in the compensation networks of an automatic control system, or in the synthesis of an equalizing network, for example, he will choose the RC network over the RL network whenever possible. The reasons for this choice are the smaller losses present in a physical capacitor, its lower cost, and the better approximation which the mathematical model makes to the physical element it is intended to represent.

Let us see how closely the analysis of the parallel (or is it series?) RC circuit corresponds to that of the RL circuit. The RC circuit is shown in Fig. 5-10. We shall assume an initial stored energy in the capacitor by selecting

$$e(0) = E_0$$

The total current leaving the node at the top of the circuit diagram must be zero, and, therefore,

$$C \frac{de}{dt} + \frac{e}{R} = 0$$

Division by C gives us

$$\frac{de}{dt} + \frac{e}{RC} = 0 \tag{5-14}$$

Equation (5-14) has a familiar form; comparison with Eq. (5-1),

$$\frac{di}{dt} + \frac{R}{L}i = 0 \tag{5-1}$$

shows that the replacement of i by e and L/R by RC produces the identical equation we considered previously. It should, for the RC circuit we are now analyzing is the dual of the RL circuit we considered first. This duality forces

$e(t)$ for the *RC* circuit and $i(t)$ for the *RL* circuit to have identical expressions if the resistance of one circuit is equal to the reciprocal of the resistance of the other circuit and if L is numerically equal to C . Thus, the response of the *RL* circuit,

$$i(t) = i(0)\epsilon^{-Rt/L} = I_0\epsilon^{-Rt/L}$$

enables us to write immediately

$$e(t) = e(0)\epsilon^{-t/RC} = E_0\epsilon^{-t/RC} \quad (5-15)$$

for the *RC* circuit.

Now let us suppose that we had selected the current i as our variable in the *RC* circuit, rather than the voltage e . Applying Kirchhoff's voltage law,

$$\frac{1}{C} \int_{t_0}^t i \, dt - e(t_0) + iR = 0$$

we obtain an integral equation and not a differential equation. However, if we take the time derivative of both sides of this equation,

$$\frac{i}{C} + R \frac{di}{dt} = 0 \quad (5-16)$$

and replace i by e/R ,

$$\frac{e}{RC} + \frac{de}{dt} = 0$$

we obtain Eq. (5-14) again. Equation (5-16) could have been used as our starting point, but duality would not have appeared as naturally.

Let us discuss the physical nature of the voltage response of the *RC* circuit as expressed by Eq. (5-15). At $t = 0$ we obtain the correct initial condition, and as t becomes infinite the voltage approaches zero. This latter result agrees with our thinking that if there were any voltage remaining across the capacitor, then energy would continue to flow into the resistor and be dissipated as heat. Thus, a final voltage of zero is necessary. The time constant of the *RC* circuit may be found by using the duality relationships on the expression for the time constant of the *RL* circuit, or it may be found by simply noting the time at which the response has dropped to 36.8 per cent of its initial value,

$$\frac{\tau}{RC} = 1$$

and $\tau = RC \quad (5-17)$

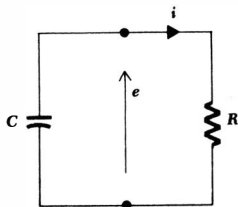

Fig. 5-10 A parallel *RC* circuit for which $e(t)$ is to be determined, subject to the initial condition that $e(0) = E_0$.

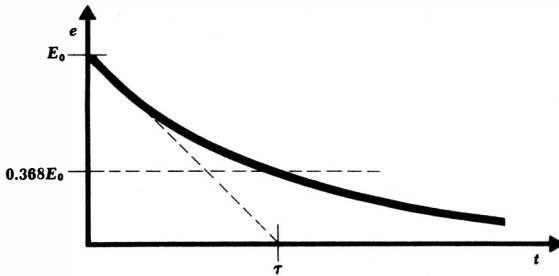

Fig. 5-11 The capacitor voltage $e(t)$ in the parallel RC circuit is plotted as a function of time. The initial value of $e(t)$ is assumed to be E_0 .

Our familiarity with the negative exponential and the significance of the time constant τ enables us to sketch the response curve readily, Fig. 5-11. Larger values of R or C provide a larger time constant and a slower dissipation of the stored energy. A larger resistance will dissipate a smaller power with a given voltage across it, thus requiring a greater time to convert the stored energy into heat; a larger capacitance stores a larger energy with a given voltage across it, again requiring a greater time to lose this initial energy.

Drill Problems

5-8 Determine $e(0)$ in each circuit of Fig. 5-12.

Ans. 0 volts; 28 volts; 60 volts

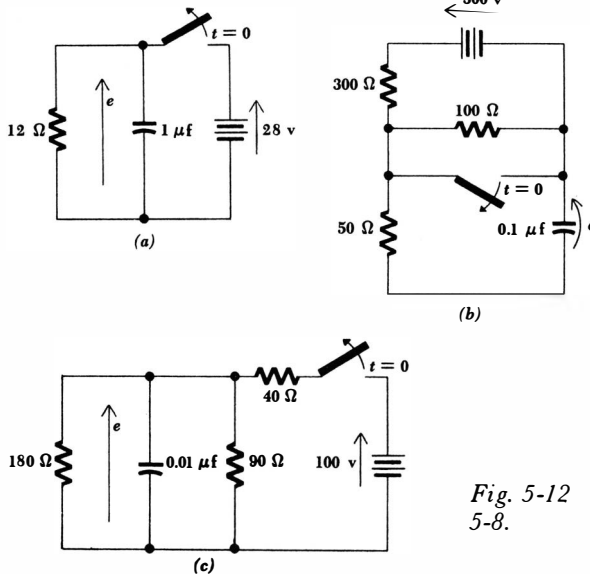

Fig. 5-12 See Drill Prob. 5-8.

5-9 A 0.01- μf capacitor is in series with a 10-kilohm resistor. The capacitor voltage is initially 100 volts. Find the time which: (a) represents one time constant; (b) is required for the capacitor voltage to drop to 10 volts; (c) is required for the rate of decrease of capacitor voltage to become one-half of its initial value.

Ans. 69.3 μsec ; 100 μsec ; 230 μsec

5-6 A MORE GENERAL RC CIRCUIT

Many of the RC circuits for which we would like to find the natural response contain more than a single resistor and capacitor. Just as we did for the RL circuits, we shall first consider several special cases and save the general case for the final section in this chapter.

Let us suppose first that we are faced with a circuit containing only one capacitor, but any number of resistors. It is possible to replace the two-terminal resistive network which is across the capacitor terminals by an equivalent resistance, and we may then write down the expression for the capacitor voltage immediately. For example, the circuit shown in Fig. 5-13a may be simplified to that of Fig. 5-13b, enabling us to write

$$e = E_0 e^{-t/R_{eq}C}$$

where

$$e(0) = E_0 \quad \text{and} \quad R_{eq} = R_2 + \frac{R_1 R_3}{R_1 + R_3}$$

Every current and voltage in the resistive portion of the network must have the form $Ae^{-t/R_{eq}C}$, where A is the initial value of that current or voltage. Thus, the current in R_1 , for example, may be expressed as

$$i_1 = i_1(0^+) e^{-t/\tau}$$

where

$$\tau = \left(R_2 + \frac{R_1 R_3}{R_1 + R_3} \right) C$$

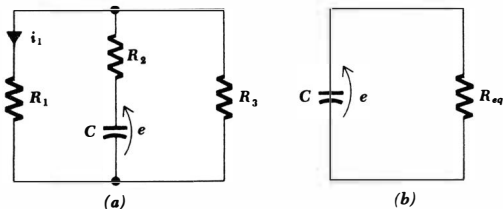

Fig. 5-13 (a) A given circuit containing one capacitor and several resistors. (b) The resistors have been replaced by a single equivalent resistor; the time constant is now obvious.

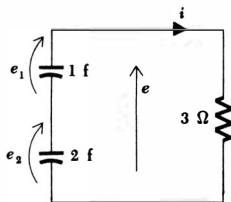

Fig. 5-14 A simple circuit illustrating the possibility of a nonzero final voltage across each of two series capacitors.

and $i_1(0^+)$ remains to be determined from some initial condition. Suppose that $e(0)$ is given. Since e cannot change instantaneously, we may think of the capacitor as being replaced by an $e(0)$ -volt ideal d-c source. Thus,

$$i_1(0^+) = \frac{e(0)}{R_2 + R_1 R_3 / (R_1 + R_3)} \frac{R_3}{R_1 + R_3}$$

The solution is obtained by collecting these results.

Another special case includes those circuits containing one resistor and any number of capacitors. The resistor voltage is easily obtained by establishing the value of the equivalent capacitance and determining the time constant. Again, there is an exception to be considered here just as there was in circuits containing several inductances. Two capacitors in *series* may “trap” a voltage; equal and opposite voltages on the two capacitors yield zero voltage across the combination. Energy is still stored, and it cannot be dissipated. Such a problem is best worked by a simple step-by-step procedure, as illustrated by the simple case of Fig. 5-14. Let us assume initial voltages

$$e_1(0) = 90 \quad e_2(0) = 0$$

The equivalent capacitance is $\frac{2}{3}$ farad, the time constant is 2 sec, and therefore

$$e(t) = 90e^{-t/2}$$

The voltage across the upper capacitor is now obtained by finding first the current i ,

$$i = \frac{e}{R}$$

$$\text{or} \quad i = -C_{eq} \frac{de}{dt}$$

from which

$$i = 30e^{-t/2}$$

The voltage e_1 is, therefore,

$$e_1 = -\frac{1}{C_1} \int_0^t i dt + e_1(0) = 60e^{-t/2} - 60 + 90$$

Thus,

$$e_1 = 30 + 60e^{-t/2}$$

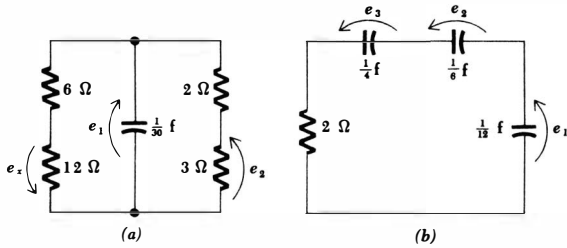

Fig. 5-15 (a) See Drill Prob. 5-10 and Prob. 30. (b) See Drill Prob. 5-11.

Knowing e and e_1 , we easily find that

$$e_2 = -30 + 30e^{-t/2}$$

Some circuits containing a number of both resistors and capacitors may be replaced by an equivalent circuit containing only one resistor and one capacitor; it is necessary that the original circuit be one which can be broken into two parts, one containing all resistors and the other containing all capacitors, such that the two parts are connected by only two ideal conductors. This is not possible in general.

Drill Problems

5-10 Find $e_x(t)$ at $t = 0.1$ sec for the circuit shown in Fig. 5-15a if: (a) $e_x(0^+) = 10$ volts; (b) $e_1(0) = 10$ volts; (c) $e_2(0^+) = 10$ volts.

Ans. 4.65 volts; -5.17 volts; -3.10 volts

5-11 For the circuit of Fig. 5-15b, find the value which e_1 approaches as t becomes infinite, given the initial conditions: (a) $e_1(0) = 6$ volts, $e_2(0) = 0$, $e_3(0) = 0$; (b) $e_1(0) = 6$ volts, $e_2(0) = 4$ volts, $e_3(0) = 1$ volt; (c) $e_1(0) = 6$ volts, $e_2(0) = 3$ volts, $e_3(0) = 2$ volts.

Ans. 0 volts; 0 volts; 2.73 volts

5-12 Find the time constant of each of the RC circuits shown in Fig. 5-16.

Ans. 1.42 sec; 1.76 sec; 0.24 sec

Fig. 5-16 See Drill Prob. 5-12.

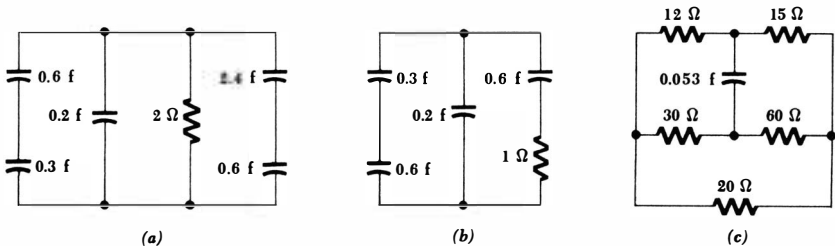

5-7 GENERAL *RL* AND *RC* CIRCUITS

A circuit containing several resistances and several inductances does not in general possess a form which allows either the resistances or inductances to be combined into single equivalent elements. There is no single negative exponential term or single time constant associated with the circuit. Rather, there will in general be several negative exponential terms, the number of terms being equal to the number of inductances which remain after all possible inductor combinations have been made. A similar condition holds for a general *RC* circuit, but for simplicity we shall restrict our attention to *RL* circuits.

Let us visualize the problem which now confronts us. We have a circuit which must contain more than one mesh, and hence a knowledge of several mesh currents is required to describe the response. Each of these mesh currents will be expressed as the sum of a number of negative exponentials, and each exponential will have an unknown amplitude and an unknown time constant. This represents a lot of unknown information. Our situation becomes somewhat more cheerful when we realize that each mesh current should contain exponential terms with the same time constants as every other mesh current. This appears plausible when we stop to consider that the voltages and currents throughout the circuit are related by a constant multiplier (resistors) or by differentiation or integration (inductors). Sums of these operations are also possible. Since none of these operations changes the exponent, we expect that each current or voltage must contain terms with every possible exponent. At any rate, we shall make this assumption; if we can satisfy the differential equations and the initial conditions, our assumption will be proved correct.

Before we illustrate this method by an example, it must be realized that there are better and easier ways to find the natural response of these more complex circuits. One of the methods will appear toward the end of Chap. 14; it is based on the concept of complex frequency. The most powerful method relies on the use of the Laplace transform and will be studied in a subsequent course.

Let us consider a specific circuit containing two inductors and two resistors, shown in Fig. 5-17. Mesh currents are assigned and the appropriate set of mesh equations is written,

$$i_1 + 5 \frac{di_1}{dt} - 3 \frac{di_2}{dt} = 0 \quad (5-18)$$

$$-3 \frac{di_1}{dt} + 3 \frac{di_2}{dt} + 2i_2 = 0 \quad (5-19)$$

We shall assume that the initial values of i_1 and i_2 are known; let them be $i_1(0)$ and $i_2(0)$. We next assume an appropriate form for i_1 and i_2 and substitute the assumed expressions into the differential equations. We shall select a form for i_1 and i_2 which is the sum of two exponentials,

$$i_1 = A\epsilon^{s_1 t} + B\epsilon^{s_2 t} \quad (5-20)$$

$$i_2 = C\epsilon^{s_1 t} + D\epsilon^{s_2 t} \quad (5-21)$$

and then substitute these expressions into the differential equations

Fig. 5-17 An RL circuit having a response which must be described by the sum of two negative exponentials. See Drill Prob. 5-14.

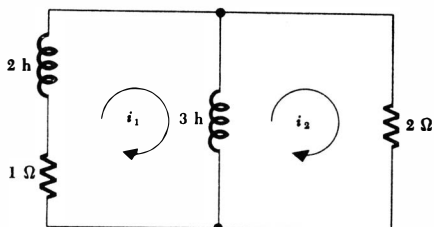

$$A\epsilon^{s_1 t} + B\epsilon^{s_2 t} + 5A s_1 \epsilon^{s_1 t} + 5B s_2 \epsilon^{s_2 t} - 3C s_1 \epsilon^{s_1 t} - 3D s_2 \epsilon^{s_2 t} = 0$$

$$-3A s_1 \epsilon^{s_1 t} - 3B s_2 \epsilon^{s_2 t} + 3C s_1 \epsilon^{s_1 t} + 3D s_2 \epsilon^{s_2 t} + 2C\epsilon^{s_1 t} + 2D\epsilon^{s_2 t} = 0$$

After factoring the exponentials,

$$(A + 5A s_1 - 3C s_1)\epsilon^{s_1 t} + (B + 5B s_2 - 3D s_2)\epsilon^{s_2 t} = 0$$

$$(-3A s_1 + 3C s_1 + 2C)\epsilon^{s_1 t} + (-3B s_2 + 3D s_2 + 2D)\epsilon^{s_2 t} = 0$$

we realize that, in order that these expressions be zero for every value of t , each sum in parentheses must be zero. Hence, we obtain the four equations

$$(5s_1 + 1)A - 3s_1 C = 0 \quad (5-22)$$

$$(5s_2 + 1)B - 3s_2 D = 0 \quad (5-23)$$

$$(3s_1 + 2)C - 3s_1 A = 0 \quad (5-24)$$

$$(3s_2 + 2)D - 3s_2 B = 0 \quad (5-25)$$

Eliminating A between Eqs. (5-22) and (5-24), we have

$$\frac{3s_1 C}{5s_1 + 1} = \frac{(3s_1 + 2)C}{3s_1}$$

or $6s_1^2 + 13s_1 + 2 = 0$

and $s_1 = -\frac{1}{6}, -2$

A similar manipulation of Eqs. (5-23) and (5-25) yields

$$s_2 = -\frac{1}{6}, -2$$

It makes no difference which answer is called s_1 and which is s_2 ; so we arbitrarily pick

$$s_1 = -\frac{1}{6} \quad s_2 = -2$$

Thus,

$$i_1 = A\epsilon^{-t/6} + B\epsilon^{-2t} \quad (5-26)$$

$$i_2 = C\epsilon^{-t/6} + D\epsilon^{-2t} \quad (5-27)$$

The next step is the determination of A , B , C , and D . The given initial conditions must now be applied,

$$i_1(0) = A + B \quad (5-28)$$

$$i_2(0) = C + D \quad (5-29)$$

These two equations are not sufficient to determine the four constants, and recourse must be had to Eqs. (5-22) to (5-25). In other words, the differential equations impose certain restrictions between the amplitudes of the several current components. Let us select Eqs. (5-22) and (5-23),

$$(-\frac{2}{3} + 1)A + \frac{1}{2}C = 0 \quad (-10 + 1)B + 6D = 0$$

$$\text{or} \quad A + 3C = 0 \quad (5-30)$$

$$-9B + 6D = 0 \quad (5-31)$$

The four equations (5-28) to (5-31) may be solved by eliminating variables or determinants. The results are easily obtained:

$$A = \frac{2}{3}i_1(0) - \frac{2}{3}i_2(0)$$

$$B = \frac{2}{3}i_1(0) + \frac{2}{3}i_2(0)$$

$$C = -\frac{2}{3}i_1(0) + \frac{2}{3}i_2(0)$$

$$D = \frac{2}{3}i_1(0) + \frac{2}{3}i_2(0)$$

and the substitution of these results into Eqs. (5-26) and (5-27) completes the mathematical solution. This circuit is analyzed by a much simpler method in Sec. 14-7.

Let us select numerical values for the initial conditions and try to interpret the solution physically. Suppose we let $i_1(0) = 11$ and $i_2(0) = 11$. The initial current in the 3-henry coil is, therefore,

$$i_1(0) - i_2(0) = 11 - 11 = 0$$

although 11 amp is flowing in the 2-henry coil at $t = 0$.

After evaluating the four amplitudes, we obtain

$$i_1 = 3e^{-t/6} + 8e^{-2t} \quad (5-32)$$

$$i_2 = -e^{-t/6} + 12e^{-2t} \quad (5-33)$$

$$\text{and} \quad i_1 - i_2 = 4e^{-t/6} - 4e^{-2t}$$

The currents flowing in the two coils i_1 and $i_1 - i_2$ are sketched in Fig. 5-18a and b by taking the difference or sum of the two exponential terms graphically. Energy is initially present in the 2-henry coil, but its value drops quickly at first as some of the energy is transferred to the 3-henry coil. This transfer is required because the initial voltage across the 2-ohm resistor is 22 volts, and thus an initial rate of increase of current in the 3-henry coil of $\frac{22}{3}$ amp/sec is established. Similarly, the current in the 2-henry coil decreases initially at the rate of 15.5 amp/sec. Thus, energy is leaving the 2-henry coil, some being transferred to the 3-henry coil, but most being dissipated as heat in the two resistors.

The two time constants, 6 sec and 0.5 sec, are not apparent in the circuit itself. Since they are quite unequal, however, we can at least identify the parts of the circuit which contribute to the longer and shorter time constant. For example, we may think of the circuit initially as being approximately a 2-henry coil in series with a 3-ohm resistor. The 3-henry coil is drawing a very small current; so we shall temporarily ignore it. The time constant of the early ac-

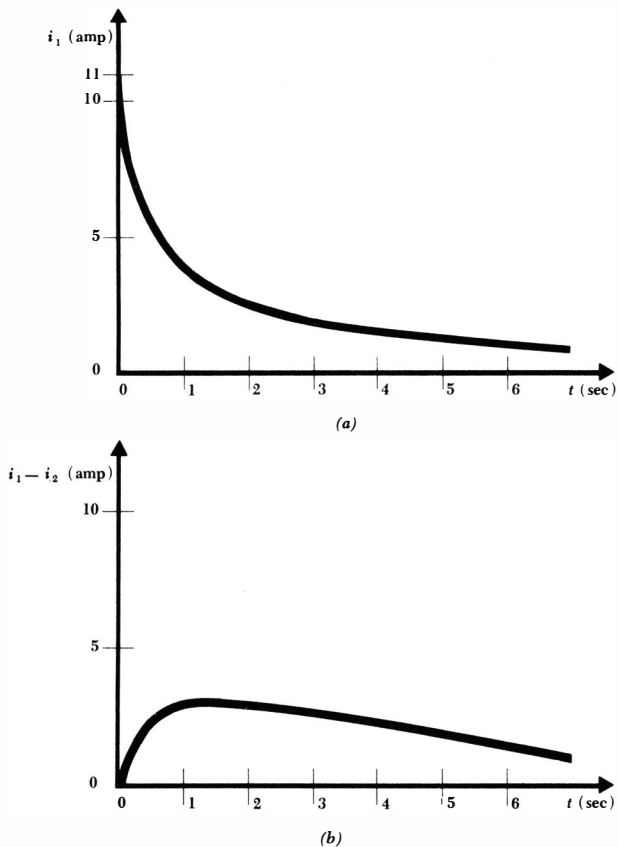

Fig. 5-18 The current in (a) the 2-henry coil and (b) the 3-henry coil shown in Fig. 5-17.

tion is thus about $2/(1 + 2)$ or $\frac{2}{3}$ sec. At a much later time, the action slows down, a small rate of change of current is evident, and small voltages are present across both coils. Thus, a smaller voltage is across the 2-ohm resistor. If we ignore it completely, the circuit acts as a 5-henry coil in series with a 1-ohm resistor. Thus the time constant is about 5 sec.

Drill Problems

5-13 Find the smaller of the two time constants associated with each of the circuits shown in Fig. 5-19.

Ans. 1 sec; 0.333 sec; 1.586 sec

5-14 For the circuit of Fig. 5-17, as described by Eqs. (5-32) and (5-33), find the energy: (a) initially stored in the 2-henry inductor;

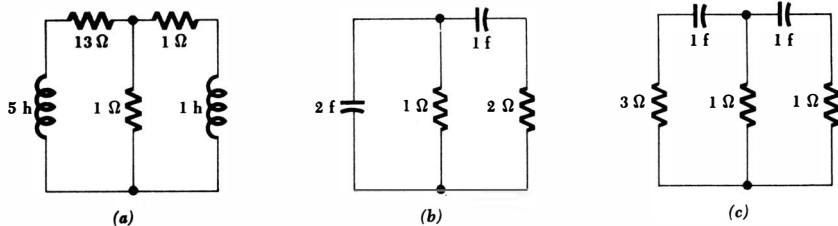

Fig. 5-19 See Drill Prob. 5-13.

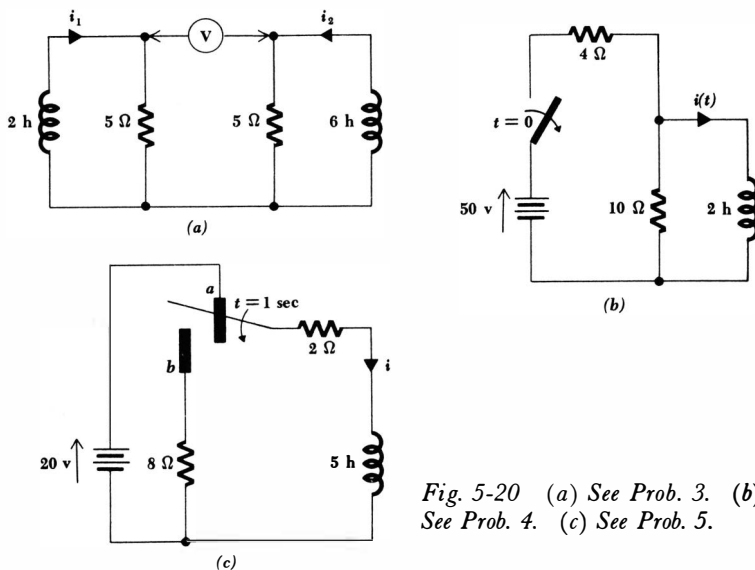

Fig. 5-20 (a) See Prob. 3. (b) See Prob. 4. (c) See Prob. 5.

(b) dissipated in the 1-ohm resistor from $t = 0$ to ∞ ; (c) dissipated in the 2-ohm resistor from $t = 0$ to ∞ .

Ans. 121 joules; 65.2 joules; 55.8 joules

Problems

- ◆1 A 100-ohm resistor is in series with a 10-mh inductor. If the current is 0.1 amp at $t = 0$, find the magnitude of the resistor voltage at: (a) $t = 0$; (b) $t = 75 \mu\text{sec}$; (c) $t = 250 \mu\text{sec}$.
- 2 A 1.2-henry coil and a 6-ohm resistor are in series. If the current has a magnitude of 5 amp at $t = 0.25$ sec, what was the inductor current magnitude and energy at $t = 0$?

- ◆3 In the circuit shown in Fig. 5-20a, the voltmeter may be assumed to have essentially infinite resistance. If i_1 is 5 amp at $t = 0$ and i_2 is 2 amp at $t = 0$, at what time does the voltmeter read zero?
- 4 After being closed for a long time, the switch of Fig. 5-20b is opened at $t = 0$. Find $i(t)$.
- ◆5 The switch in the circuit of Fig. 5-20c has been in position “a” for a long time. It is thrown to “b” at $t = 1$ sec. Find $i(t)$.
- 6 For the RL circuit shown in Fig. 5-21a, $i = 20$ amp at $t = 0$. Find: (a) $i(t)$; (b) the time constant τ ; (c) w_L at $t = 0$; (d) the time at which w_L is one-half of its initial value; (e) e_R ; (f) e_L ; (g) rate of change of current at $t = 0$; (h) i at 15 msec after $t = 0$.
- 7 Let us assume a mass m with a velocity v_0 at $t = 0$, sliding along an oiled horizontal surface. The frictional retarding force is proportional to velocity, the constant of proportionality being d . Greater friction corresponds to a larger value for d . (a) Write the differential equation governing the velocity of the mass and describe the analogy with an electric circuit. (b) If $m = 10$ kg, $v_0 = 20$ m/sec, and $d = 2.5$ kg/sec, find the velocity after 5 sec has elapsed. (c) How far does the mass slide before it stops?
- ◆8 The switch in the circuit of Fig. 5-21b has been at “a” for a long time. At $t = 0$ it is thrown to “b,” and at $t = 2$ sec it is then thrown to “c.” Find $i(t)$ for each of the time intervals $t \leq 0, 0 \leq t \leq 2, t \geq 2$.
- 9 In the circuit of Fig. 5-22a, the switch is suddenly opened. What happens to the energy in the coil? How might the coil circuit be safely opened?
- ◆10 A resistance R and an inductance L are in series. A voltmeter across the inductor indicates a voltage of 100 volts at $t = 0$ and 50 volts at $t = 4$ sec. Find the time constant.
- 11 A 5-henry inductor is in series with a 10-ohm resistor and a 100-volt d-c supply. A (0–300 volt) d-c voltmeter having a resistance of 10,000 ohms is in parallel with the inductor. It reads zero at $t = 0^-$. The battery is suddenly disconnected at $t = 0$. Describe the voltage across the voltmeter as a function of time, from $t = 0^-$ to burnout.
- ◆12 A camera and an oscilloscope are used to obtain the current response of a physical coil, which we may assume consists of an inductance L and a resistance R_L in series. Response curves are obtained for the coil itself and

Fig. 5-21 (a) See Prob. 6. (b) See Prob. 8.

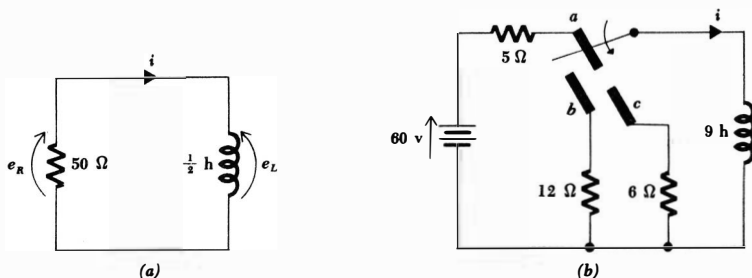

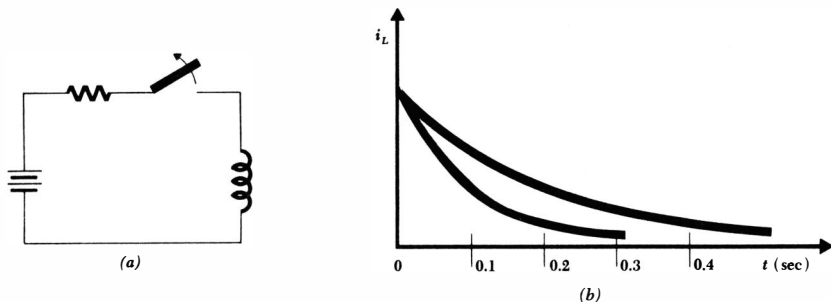
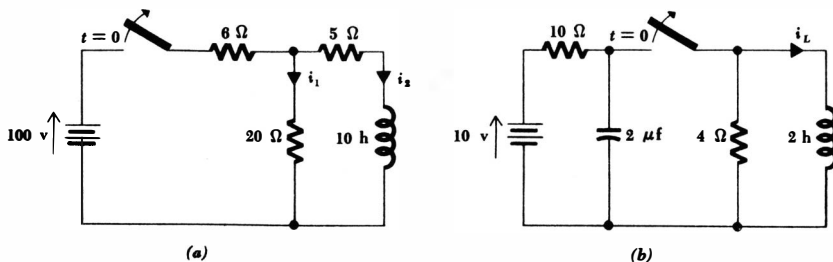

Fig. 5-22 (a) See Prob. 9. (b) See Prob. 12.

the coil with an additional 20-ohm resistor in series. The oscillograms are shown in Fig. 5-22b. Determine approximate values for L and R_L . Which curve is which?

- 13 In the circuit of Fig. 5-23a, the switch has been closed for a long time. It is opened at $t = 0$. Sketch i_1 and i_2 as functions of time for the interval $-1 \leq t \leq 1$.
- 14 Sketch i_L versus t for the circuit of Fig. 5-23b. Assume that the switch has been closed since noon yesterday.
- ◀15 The switch in the circuit of Fig. 5-24a has been open for a long time. It is closed at $t = 0$. Find $i_L(t)$.
- ◀16 After having been open for a very long time, the switch in Fig. 5-24b is closed at $t = 0$. Find $i_1(t)$, $i_2(t)$, and $i_3(t)$ for $t < 0$ and $t > 0$.
- 17 Find $i_x(t)$ for each circuit shown in Fig. 5-25 if $i_L(0) = 8$ amp.
- 18 The switch shown in Fig. 5-26a “breaks” before it “makes.” It has been in position “a” for a long time; at $t = 0$ it is thrown to position “b.” What is the magnitude of the voltage across the 12-ohm resistor when the switch is: (a) at “a”? (b) between “a” and “b”? (c) just contacting “b”? (d) At what time is the voltage across the 12-ohm resistor 10 volts?
- ◀19 For the circuit shown in Fig. 5-26b, $i_1(0) = 8$ ma, $i_2(0) = 4$ ma. Find: (a) $i(0)$; (b) τ ; (c) $i(t)$; (d) $i_1(t)$; (e) $i_2(t)$; (f) $i(\infty)$; (g) $i_1(\infty)$; (h) $i_2(\infty)$.

Fig. 5-23 (a) See Prob. 13. (b) See Prob. 14.



- 20 Find the energy stored in L_1 , L_2 , and L_3 at both $t = 0$ and $t = \infty$. It is known that $i_1(0) = 8$ amp and $i_3(0) = 12$ amp. The circuit is shown in Fig. 5-27a.
- 21 Find $e(t)$ for the circuit shown in Fig. 5-27b if: (a) $e(0) = 100$ volts, $R = 10$ kilohms, $C = 100$ pf; (b) $w_C(0) = 0.01$ joule, $C = 0.5 \mu\text{f}$, $R = 10$ ohms; (c) $i(0) = 50$ ma, $e(0) = -1000$ volts, $C = 0.01 \mu\text{f}$.
- 22 For the parallel RC circuit, show that the total energy dissipated in the resistor is equal to the energy stored initially in the capacitor.
- 23 A 200-ohm resistor is in parallel with a $5\text{-}\mu\text{f}$ capacitor. If the current is 0.5 amp at $t = 0$, find the magnitude of the resistor voltage at: (a) $t = 0$; (b) $t = 0.6$ msec; (c) $t = 1.8$ msec.
- 24 A 5-ohm resistor and a 0.1-farad capacitor are in parallel. If the voltage has a magnitude of 8 volts at $t = 1$ sec, find the capacitor voltage magnitude and energy at $t = 0$.
- 25 A $0.01\text{-}\mu\text{f}$ capacitor and a 10,000-ohm resistor are in parallel. If the capacitor voltage is 100 volts at $t = 0$: (a) sketch the resistor current as a

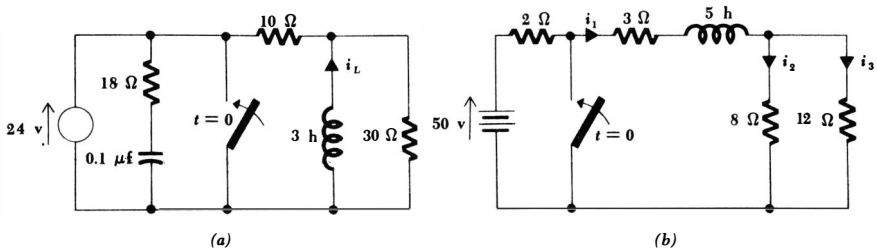

Fig. 5-24 (a) See Prob. 15. (b) See Prob. 16.

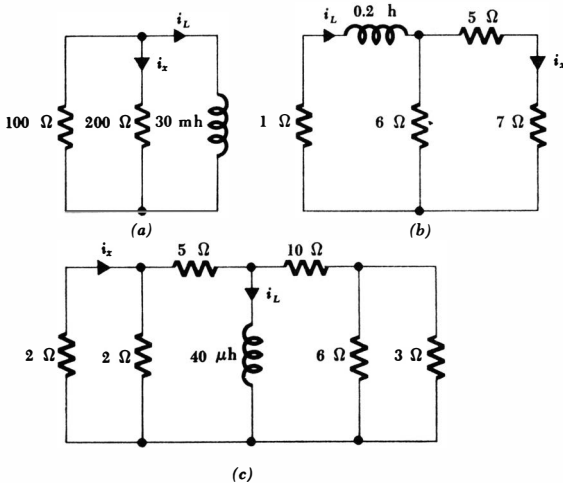

Fig. 5-25 See Prob. 17.

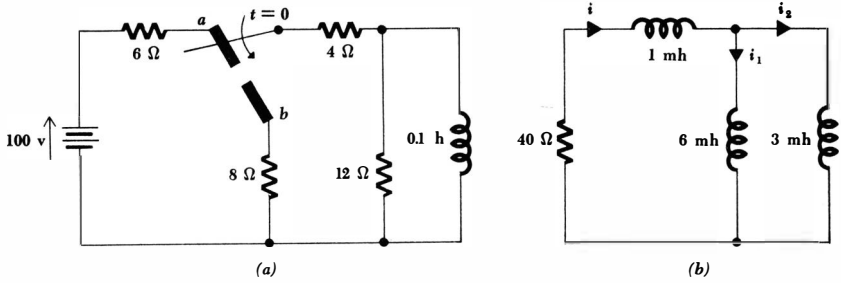

Fig. 5-26 (a) See Prob. 18. (b) See Prob. 19.

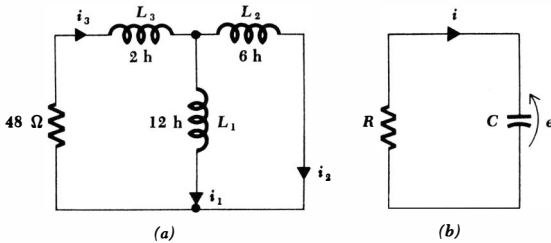

Fig. 5-27 (a) See Prob. 20. (b) See Prob. 21.

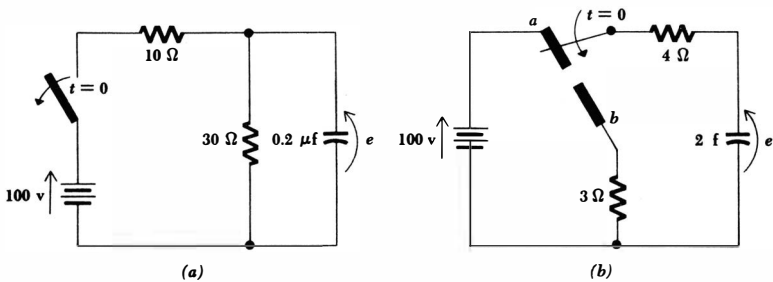

Fig. 5-28 (a) See Prob. 26. (b) See Probs. 27 and 29.

function of time; **(b)** find the energy stored in the capacitor when the resistor current is 5 ma.

- 26 The switch in the circuit of Fig. 5-28a has been closed for a long time. It is opened at $t = 0$. Find $e(t)$.
- 27 The switch in Fig. 5-28b has been in position "a" for a long time. It is thrown to "b" at $t = 0$. Find: **(a)** $e(t)$; **(b)** $w_C(t)$; **(c)** τ ; **(d)** e at $t = 21$ sec; **(e)** e at $t = \infty$.
- 28 In the circuit shown in Fig. 5-29a, it is known that $i_{R1}(0^+) = 10$ amp. Find $i_{R1}(t)$ and $i_{R2}(t)$ for $t > 0$.

- 29 Repeat Prob. 27 if a 21-ohm resistor is in parallel with the capacitor for $-\infty < t < \infty$.
- ◆30 A 28-volt battery is in parallel with the 2-ohm resistor of Fig. 5-15a. The upper terminal is positive. At $t = 0$, the battery is suddenly disconnected. Find $e_1(t)$, $e_2(t)$, and $e_x(t)$ for $t > 0$ and $t < 0$.
- 31 Let us assume that the circuit shown in Fig. 5-29b has been operating in a satellite for 58 days when a meteorite suddenly separates the circuit into two parts, as shown by the broken line. Find $e_1(t)$ and $e_2(t)$, where time is measured from the meteorite impact.
- ◆32 The ammeter included in the circuit of Fig. 5-30a has zero resistance. If $e_C(0) = 10$ volts and $i_L(0) = 4$ amp: (a) plot i_A versus t , and (b) determine whether or not the ammeter current magnitude will ever exceed 1 amp.

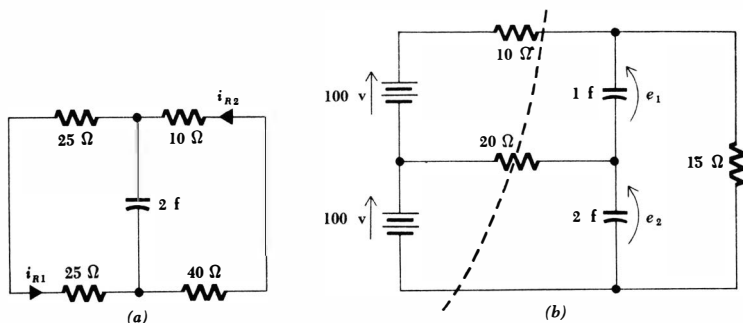

Fig. 5-29 (a) See Prob. 28. (b) See Prob. 31.

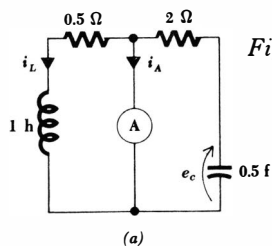
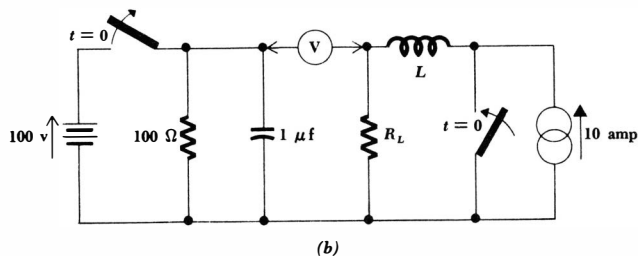

Fig. 5-30 (a) See Prob. 32. (b) See Prob. 33.



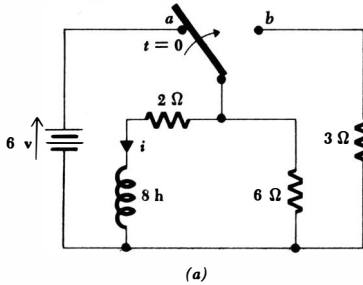
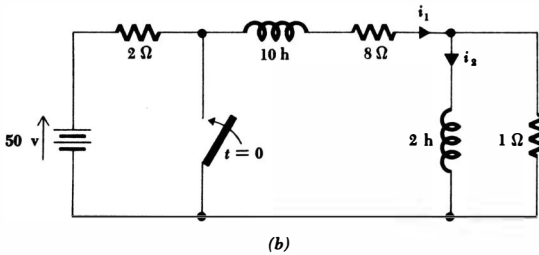

Fig. 5-31 (a) See Prob. 34.
(b) See Prob. 35.



- 33 The two switches in the circuit shown in Fig. 5-30b are thrown simultaneously at $t = 0$. The ideal voltmeter shows no deflection either before or after $t = 0$. Find R_L and L .
- ◆34 In the circuit shown in Fig. 5-31a, the switch has been in position “a” for a long time. At $t = 0$ it is thrown to “b.” (a) Find $i(t)$. (b) Find the total energy delivered to the 2-ohm resistor during the first 1-sec interval after $t = 0$.
- 35 Find $i_1(t)$ and $i_2(t)$ for the circuit of Fig. 5-31b.

Chapter 6 *The Application of the Unit-step Forcing Function*

6-1 INTRODUCTION

We have just spent a chapter's worth of our time studying the response of RL and RC circuits when no source or forcing function was present. We termed this response the natural response because its form depends only on the nature of the circuit. The reason that any response at all is obtained arises from the possibility of an initial energy storage within the inductive or capacitive elements in the circuit. In several of the examples and problems, we were confronted with circuits containing sources and switches; we were informed that certain switching operations were performed at $t = 0$ in order to remove all the sources from the circuit, while leaving known amounts of energy stored here and there. In other words, we have been solving problems in which energy sources are suddenly *removed* from the circuit; now we must consider that type of response which results when energy sources are suddenly *applied* to a circuit.

We shall devote this chapter to a study of the response which occurs when the energy sources which are suddenly applied are d-c sources. After we have studied sinusoidal and exponential sources, we may then consider the general problem of the sudden application of a more general source. Since every electrical device is intended to be energized at least once, and since most devices are turned on and off many times in the course of their lives, it should be evident that our study will be applicable to many practical cases. Even though we are now restricting ourselves to d-c sources, there are still innumerable cases in which these simpler examples correspond to the operation of physical devices. For example, the first circuit we shall analyze may be considered to represent the build-up of the field current when a d-c motor is started. The generation and use of the rectangular voltage pulses needed to represent a number or a command in a digital computer provide many examples in the field of electronic or transistor circuitry. Similar circuits are found in the synchronization and sweep circuits of television receivers, in communication systems using pulse mod-

ulation, and in radar systems, to name but a few examples. Furthermore, an important part of the analysis of most servomechanisms is the determination of their responses to suddenly applied constant inputs.

6-2 THE UNIT-STEP FORCING FUNCTION

We have been speaking of the “sudden application” of an energy source, and by this phrase we imply its application in zero time. The operation of a switch in series with a battery is thus equivalent to a forcing function which is zero up to the instant that the switch is closed and is equal to the battery voltage thereafter. The forcing function has a break or discontinuity at the instant the switch is closed. Certain special forcing functions which are discontinuous or have discontinuous derivatives are called *singularity functions*, the three most important of these singularity functions being the unit-step function, the unit-impulse function, and the doublet. The unit-step function is the subject of this chapter, and the following chapter is devoted to the unit impulse and the doublet.

We define the *unit-step function* as a function which is zero for all values of its argument which are less than zero and which is unity for all positive values of its argument. If we let x be the argument and represent the unit-step function by u , then $u(x)$ must be zero for all values of x less than zero, and it must be unity for all values of x greater than zero. At $x = 0$, $u(x)$ changes abruptly from 0 to 1. Its value at $x = 0$ is not defined, but its value is known for all points arbitrarily close to $x = 0$. We often indicate this by writing $u(0^-) = 0$ and $u(0^+) = 1$. The concise mathematical definition of the unit-step function is

$$u(x) = \begin{cases} 0 & x < 0 \\ 1 & x > 0 \end{cases}$$

and it is shown graphically in Fig. 6-1.

In order to obtain a unit-step *forcing* function, we must express the unit step as a function of time, and the simplest expression is obtained by replacing x by t ,

$$u(t) = \begin{cases} 0 & t < 0 \\ 1 & t > 0 \end{cases}$$

However, we cannot always arrange the operation of a circuit so that every discontinuity occurs at $t = 0$. If two switches are to be thrown in sequence, for example, we might elect to operate one of them at $t = 0$, and it is then necessary to throw the second switch at some later time $t = t_0$. Since the unit-step function provides us with a suitable discontinuity when the value of its argument is zero, then the operation of the second switch may be represented by selecting a unit-step forcing function having an argument $(t - t_0)$. Thus, if we let $x = t - t_0$, the unit-step forcing function $u(t - t_0)$ is seen to be

$$u(t - t_0) = \begin{cases} 0 & t < t_0 \\ 1 & t > t_0 \end{cases}$$

This function is shown in Fig. 6-2.

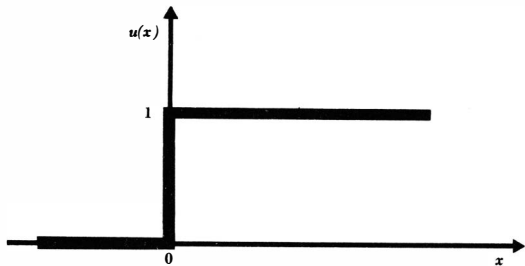

Fig. 6-1 The unit-step function $u(x)$ is shown as a function of x .

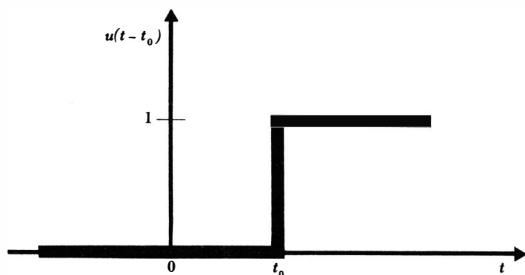

Fig. 6-2 The unit-step forcing function, $u(t - t_0)$.

The unit-step forcing function is in itself dimensionless. If we wish it to represent a voltage, it is necessary to multiply $u(t - t_0)$ by some constant voltage, such as E . Thus, $e(t) = Eu(t - t_0)$ is an ideal voltage source which is zero before $t = t_0$ and a constant E volts after $t = t_0$. This forcing function is shown connected to a general network in Fig. 6-3a. We should now logically ask what physical source is the equivalent of this discontinuous forcing function. By equivalent, we mean simply that the voltage-current characteristics of the two networks are identical. For the step-voltage source of Fig. 6-3a, the voltage-current characteristic is quite simple; the voltage is zero prior to $t = t_0$, it is E after $t = t_0$, and the current may be any (finite) value in either time interval. Our first thoughts might produce the attempt at an equivalent shown in Fig. 6-3b, a d-c source of E volts in series with a switch which closes at $t = t_0$. This network is not equivalent for $t < t_0$, however, because the voltage across the battery and switch is completely unspecified in this time interval. The "equivalent" source is an open circuit, and the voltage across it may be anything. After $t = t_0$, the networks are equivalent, and if this is the only time interval in which we are interested, and if the initial currents which flow from the two networks are identical at $t = t_0$, then Fig. 6-3b becomes a useful equivalent of Fig. 6-3a.

In order to obtain an exact equivalent for the voltage-step forcing function, we may provide a single-pole double-throw switch. Before $t = t_0$, the switch serves to ensure zero voltage across the input terminals of the general network. After $t = t_0$, the switch is thrown to provide a constant input voltage of E volts. At $t = t_0$, the voltage is indeterminate (as is the step function), the battery is

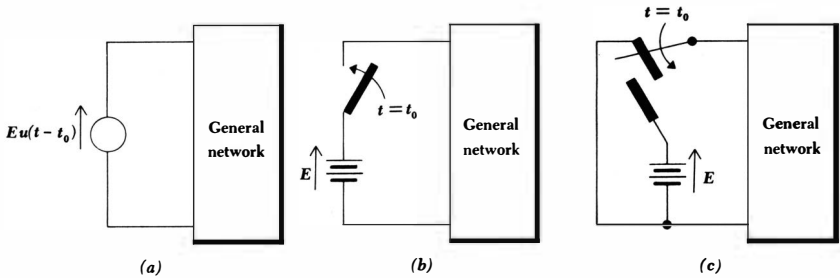

Fig. 6-3 (a) A voltage-step forcing function is shown as the source of a general network. (b) A simple circuit which, although not the exact equivalent of (a), may be used as its equivalent in many cases. (c) An exact equivalent of (a).

momentarily short-circuited, and it is fortunate that we are dealing with mathematical models. This exact equivalent of Fig. 6-3a is shown in Fig. 6-3c; exact equivalents having other forms are also possible, as indicated by Prob. 3b at the end of the chapter.

Before concluding our discussion of equivalence, it is enlightening to consider the exact equivalent of a battery and a switch. What is the voltage-step forcing function which is equivalent to Fig. 6-3b? We are searching for some arrangement which changes suddenly from an open circuit to a constant voltage; a change in resistance is involved, and this is the crux of our difficulty. The step function enables us to change a voltage discontinuously (or a current), but here we need a changing resistance as well. The equivalent therefore must contain a resistance or conductance step function, a passive element which is time-varying. Although we might construct such an element with the unit-step function, it should be apparent that the end product is a switch; a switch is merely a resistance which changes instantaneously from zero to infinite ohms, or vice versa. Thus, we conclude that the exact equivalent of a battery and switch in series must be a battery in series with some representation of a time-varying resistance; no arrangement of voltage- and current-step forcing functions is able to provide us with the exact equivalent.¹

Figure 6-4a shows a current-step forcing function driving a general network. If we attempt to replace this circuit by a d-c source in parallel with a switch (which *opens* at $t = t_0$), we must realize that the circuits are equivalent after $t = t_0$, but the responses are alike after $t = t_0$ only if the initial conditions are the same. Judiciously, then, we may often use the circuits of Fig. 6-4a and b interchangeably. The exact equivalent of Fig. 6-4a is requested in one of the problems at the end of this chapter; the exact equivalent of Fig. 6-4b cannot be constructed with current- and voltage-step forcing functions alone.²

¹ An equivalent may always be determined if some information about the general network is available (the voltage across the switch for $t < t_0$); we assume no a priori knowledge about the general network.

² The equivalent can be drawn if the current through the switch prior to $t = t_0$ is known.

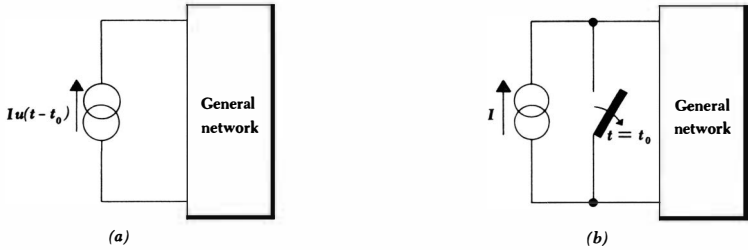

Fig. 6-4 (a) A current-step forcing function is applied to a general network. (b) A simple circuit which, although not the exact equivalent of (a), may be used as its equivalent in many cases.

Some very useful forcing functions may be obtained by manipulating the unit-step forcing function. Let us define a rectangular voltage pulse by the following conditions:

$$e(t) = \begin{cases} 0 & t < t_0 \\ E & t_0 < t < t_1 \\ 0 & t_1 < t \end{cases}$$

The pulse is drawn in Fig. 6-5. Can this pulse be represented in terms of the unit-step forcing function? Let us consider the difference of the two unit steps $u(t - t_0) - u(t - t_1)$. The two step functions are shown in Fig. 6-6a, and their difference is obviously a rectangular pulse. The source $Eu(t - t_0) - Eu(t - t_1)$ which will provide us with the desired voltage is indicated in Fig. 6-6b.

If we have a sinusoidal voltage source $E \sin \omega t$ which is suddenly connected to a network at $t = t_0$, then an appropriate voltage forcing function would be $e(t) = Eu(t - t_0) \sin \omega t$. If we wish to represent one burst of energy from a radar transmitter, we may turn the sinusoidal source off $\frac{1}{10}$ μsec later by a second unit-step forcing function. The voltage pulse is thus

$$e(t) = E[u(t - t_0) - u(t - t_0 - 10^{-7})] \sin \omega t$$

This forcing function is sketched in Fig. 6-7.

As a final introductory remark, we should note that the unit-step forcing function must be considered only as the mathematical model of an actual

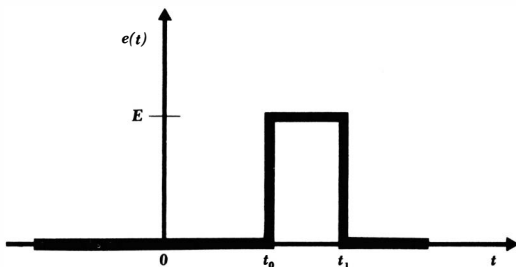

Fig. 6-5 A useful forcing function, the rectangular voltage pulse.

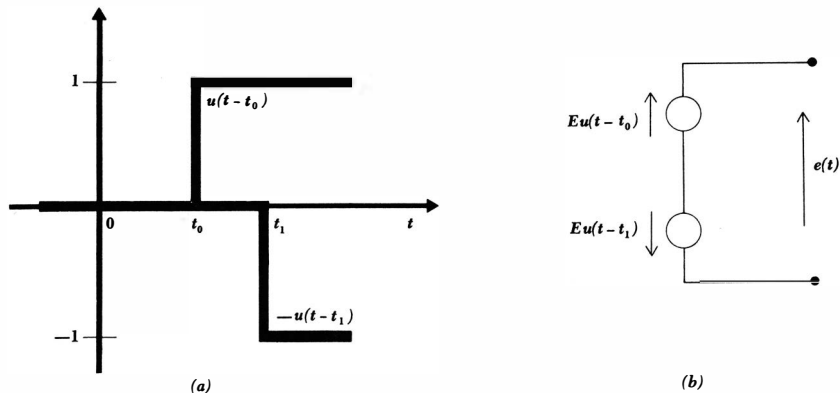

Fig. 6-6 (a) The unit steps $u(t - t_0)$ and $(-1)u(t - t_1)$. (b) A source which yields the rectangular voltage pulse of Fig. 6-5.

switching operation. No physical resistor, inductor, or capacitor behaves entirely like its idealized circuit element; we also cannot perform a switching operation in zero time. However, switching times less than 100 nanosec are common in many circuits, and this time is often sufficiently short compared with the time constants in the rest of the circuit that it may be ignored.

Drill Problems

6-1 If $e(t) = 2u(t + 2) - 3u(t - 1) + 4u(t - 3)$, find $e(t)$ at: (a) $t = 0$; (b) $t = 2$; (c) $t = 4$.

Ans. 3 volts; -1 volt; 2 volts

6-2 The current $i(t) = 2u(t) - 2u(t - 5)$ is applied to a 4-farad capacitor. Find the capacitor voltage, assuming the passive sign convention is used, at: (a) $t = -1$; (b) $t = 4$; (c) $t = 10$.

Ans. 2 volts; 0 volts; 2.5 volts

6-3 A FIRST LOOK AT THE DRIVEN RL CIRCUIT

We are now ready to subject a simple network to the sudden application of a d-c source. The circuit consists of a battery of E volts in series with a switch, a resistance R , and an inductance L . The switch is closed at $t = 0$, as indicated on the circuit diagram of Fig. 6-8a. It is evident that the current $i(t)$ is zero before $t = 0$, and we are therefore able to replace the battery and switch by a voltage-step forcing function $Eu(t)$, which also produces no response prior to $t = 0$. After $t = 0$, the two circuits are obviously identical. Hence, we seek the current $i(t)$ either in the given circuit of Fig. 6-8a or in the equivalent circuit of Fig. 6-8b.

We shall find $i(t)$ at this time by writing the appropriate circuit equation and

Fig. 6-7 A radio-frequency pulse, described by $e(t) = E[u(t - t_0) - u(t - t_0 - 10^{-7})] \sin \omega t$. The frequency of the pulse shown is about 39 Mc, a value which is too low for radar, but about right for constructing legible drawings.

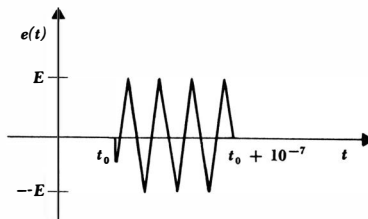

then solving it by separation of the variables and integration. After we obtain the answer and investigate the two parts of which it is composed, we shall next spend some time (the following section) in learning the general significance of these two terms. We shall then be able to construct the solution to this problem very easily; moreover, we shall be able to apply the general principles behind this simpler method to produce more rapid and more meaningful solutions to every problem involving the sudden application of any source. Let us now proceed with the more formal method of solution.

Applying Kirchhoff's voltage law to the circuit of Fig. 6-8b, we have

$$iR + L \frac{di}{dt} = Eu(t)$$

Since the unit-step function is discontinuous at $t = 0$, we shall first consider the solution for $t < 0$ and then for $t > 0$. It is evident that the application of zero voltage since $t = -\infty$ has not produced any response, and, therefore,

$$i(t) = 0 \quad t < 0$$

For positive time, however, $u(t)$ is unity and we must solve the equation

$$iR + L \frac{di}{dt} = E \quad t > 0$$

The variables may be separated in several simple algebraic steps, yielding

$$\frac{L di}{E - iR} = dt$$

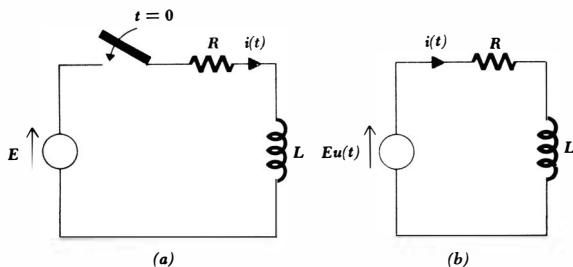

Fig. 6-8 (a) The given circuit. (b) An equivalent circuit, possessing the same response $i(t)$ for all time.

and each side may be integrated directly,

$$-\frac{L}{R} \ln(E - iR) = t + k$$

In order to evaluate k , an initial condition must be invoked. Prior to $t = 0$, $i(t)$ is zero, and thus $i(0^-) = 0$; since the current in an inductor cannot change by a finite amount in zero time without being associated with an infinite voltage, we thus have $i(0^+) = 0$. Setting $i = 0$ at $t = 0$, we obtain

$$-\frac{L}{R} \ln E = k$$

and, hence,

$$-\frac{L}{R} [\ln(E - iR) - \ln E] = t$$

Rearranging,

$$\frac{E - iR}{E} = e^{-Rt/L}$$

or
$$i = \frac{E}{R} - \frac{E}{R} e^{-Rt/L} \quad t > 0 \tag{6-1}$$

This is the desired solution, but it has not been obtained in the simplest manner. In order to establish a more direct procedure, let us try to interpret the two terms appearing in Eq. (6-1). The exponential term has the functional form of the natural response of the RL circuit; it is a negative exponential, it approaches zero as time increases, and it is characterized by the time constant L/R . The *functional form* of this part of the response is thus identical with that which is obtained in the source-free circuit. However, the amplitude of this exponential term depends on E . We might generalize, then, that the response will be the sum of two terms, where one term has a functional form which is identical with that of the source-free response, but has an amplitude which depends on the forcing function. Now let us consider the nature of the second part of the response.

Equation (6-1) also contains a constant term E/R . Why is it present? The answer is simple: the natural response approaches zero as the energy is gradually dissipated, but the total response must not approach zero. Eventually the circuit behaves as a resistor and inductor in series with a battery, and a direct current E/R flows. This current is a part of the response which is directly attributable to the forcing function, and we call it the *forced response*. It is the response which is present a long time after the switch is closed.

The complete response is composed of two parts, the natural response and the forced response. The natural response is a characteristic of the circuit and not of the sources. Its form may be found by considering the source-free circuit, and it has an amplitude which depends on the initial amplitude of the source and the initial energy storage. The forced response has the characteristics of the forcing function; it is found by pretending that all switches have been thrown

a long time ago. Since we are presently concerned only with switches and d-c sources, the forced response is merely the solution of a simple d-c circuit problem.

The reason for the two responses, forced and natural, may also be seen from physical arguments. We know that our circuit will eventually assume the forced response. However, at the instant the switches are thrown, the initial currents in the coils (or the voltages across the capacitors in other circuits) will have values which depend only on the energy stored in these elements. These currents or voltages cannot be expected to be the same as the currents and voltages demanded by the forced response. Hence, there must be a transient period during which the currents and voltages change from their given initial values to their required final values. The portion of the response which provides the transition from initial to final values is the natural response (often called the transient response, as we found earlier). If we describe the response of the *source-free* simple *RL* circuit in these terms, then we should say that the forced response is zero and that the natural response serves to connect the initial response produced by stored energy with the zero value of the forced response. This description is appropriate only for those circuits in which the natural response eventually dies out. This always occurs in physical circuits where some resistance is associated with every element, but there are a number of pathologic circuits in which the natural response is nonvanishing as time becomes infinite; those circuits in which trapped currents or voltages may exist are examples.

Now let us search out the mathematical basis for dividing the response into a natural response and a forced response.

Drill Problem

6-3 A 1.5-volt battery is suddenly connected to the series combination of a 5-ohm resistor and a 3-mh inductor. The desired response is the current leaving the positive terminal of the battery. One millisecond after the circuit is completed, determine the value of the: (a) forced response; (b) natural response; (c) total response.

Ans. -0.0566 amp; 0.3 amp; 0.243 amp

6-4 THE NATURAL AND THE FORCED RESPONSE

There is also an excellent mathematical reason for considering the complete response to be composed of two parts, the forced response and the natural response. The reason is based on the fact that the solution of any linear differential equation may be expressed as the sum of two parts, the complementary solution (natural response) and the particular solution (forced response). Without delving into the general theory of differential equations, let us consider a general equation of the type met in the previous section,

$$\frac{di}{dt} + Pi = Q \qquad (6-2)$$

We may identify Q as a forcing function and express it as $Q(t)$ to emphasize its general time dependence. In all our circuits, P will be a positive constant, but the remarks that follow about the solution of Eq. (6-2) are equally valid for the cases in which P is a general function of time. Let us simplify the discussion by assuming that P is a positive constant. Later, we shall also assume that Q is constant, thus restricting ourselves to d-c forcing functions.

In any standard text on elementary differential equations, it is shown that if both sides of this equation are multiplied by a so-called integrating factor, then each side becomes an exact differential which can be integrated directly to obtain the solution. We are not separating the variables, but merely arranging them in such a way that integration is possible. For this equation, the integrating factor is $\epsilon^{\int P dt}$ or ϵ^{Pt} , since P is a constant. We multiply each side of the equation by this integrating factor and obtain

$$\epsilon^{Pt} \frac{di}{dt} + iP\epsilon^{Pt} = Q\epsilon^{Pt}$$

The form of the left side may now be improved when it is recognized as the exact derivative of $i\epsilon^{Pt}$,

$$\frac{d}{dt} (i\epsilon^{Pt}) = \epsilon^{Pt} \frac{di}{dt} + iP\epsilon^{Pt}$$

and, thus,

$$\frac{d}{dt} (i\epsilon^{Pt}) = Q\epsilon^{Pt}$$

We may now integrate each side with respect to time, finding

$$i\epsilon^{Pt} = \int Q\epsilon^{Pt} dt + A$$

where A is a constant of integration. Since this constant is explicitly shown, we should remember that no integration constant needs to be added to the remaining integral when it is evaluated. Multiplication by ϵ^{-Pt} produces the solution for $i(t)$,

$$i = \epsilon^{-Pt} \int Q\epsilon^{Pt} dt + A\epsilon^{-Pt} \quad (6-3)$$

If $Q(t)$, the forcing function, is known, then it remains only to evaluate the integral to obtain the exact functional form for $i(t)$. We shall not evaluate such an integral for each problem, however; instead, we are interested in using Eq. (6-3) as an exemplary solution from which we shall draw several very general conclusions.

We should note first that, for a source-free circuit, Q must be zero, and the solution is therefore completely independent of $Q(t)$. This solution is the natural response

$$i_n = A\epsilon^{-Pt} \quad (6-4)$$

We shall find that the constant P is never negative; its value depends only on the passive circuit elements and their interconnection in the circuit. The natural response therefore approaches zero as time increases without limit. It must

do so, of course, in the simple RL series circuit because the energy is gradually being dissipated in the resistor. There are also idealized, nonphysical circuits in which P is zero; in these circuits the natural response does not die out, but approaches a constant value, as exemplified by trapped currents or voltages. We therefore find that one of the two terms making up the complete response has the form of the natural response; it has an amplitude which will depend on the initial value of the complete response and thus on the initial value of the forcing function also.

We next observe that the first term of Eq. (6-3) depends on the functional form of $Q(t)$, the forcing function. Whenever we have a circuit in which the natural response dies out as t becomes infinite, then this first term must describe the form of the response completely after the natural response has disappeared. This term we shall call the *forced response*; it is also called the steady-state response, the particular solution, or the particular integral.

For the present, we have elected to consider only those problems involving the sudden application of d-c sources, and $Q(t)$ is therefore a constant for all values of time after the switch has been closed. If we wish, we can now evaluate the integral in Eq. (6-3), obtaining the forced response

$$i_f = \frac{Q}{P}$$

or the complete response

$$i(t) = \frac{Q}{P} + A\epsilon^{-Pt}$$

For the RL series circuit, Q/P is the constant current E/R and $1/P$ is the time constant τ . We should see that the forced response might have been obtained without evaluating the integral, because it must be the complete response at infinite time; it is merely the source voltage divided by the series resistance. The forced response is thus obtained by inspection.

In the following section we shall attempt to find the complete response for several RL circuits by obtaining the natural and forced responses and then adding them.

Drill Problem

6-4 Replace the source shown in Fig. 6-8*b* by $e_s(t) = 6 u(t) \sin 3t$; let $R = 2$ and $L = 1$. Evaluate the integral in Eq. (6-3), and determine the current i at: (a) $t = 0$; (b) $t = \frac{1}{2}$; (c) $t = 1$.

Ans. 0 amp; 1.688 amp; 1.333 amp

6-5 RL CIRCUITS

Let us use the simple RL series circuit to illustrate the determination of the complete response by the addition of the natural and forced responses. This circuit, shown in Fig. 6-9, has been analyzed earlier, but by a longer method. The desired response is the current $i(t)$, and we first express this current as the sum

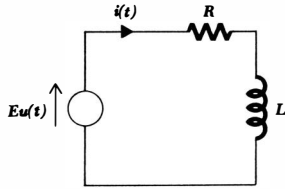

Fig. 6-9 A series RL circuit which is used to illustrate the method by which the complete response is obtained as the sum of the natural and the forced response.

of the natural and the forced current,

$$i = i_n + i_f$$

The functional form of the natural response must be the same as that obtained without any sources. We therefore replace the step-voltage source by a short circuit and recognize the old RL series loop. Thus,

$$i_n = A\epsilon^{-Rt/L}$$

where the amplitude A is yet to be determined.

We next consider the forced response, that part of the response which depends upon the nature of the forcing function itself. In this particular problem the forced response must be constant because the source is a constant E volts for all positive values of time. After the natural response has died out, therefore, there can be no voltage across the inductor; hence, a voltage E appears across R , and the forced response is simply

$$i_f = \frac{E}{R}$$

Note that the forced response is determined completely; there is no unknown amplitude. We next combine the two responses

$$i = A\epsilon^{-Rt/L} + \frac{E}{R}$$

and apply the initial condition to evaluate A . The current is zero prior to $t = 0$, and it cannot change value instantaneously since it is the current flowing through an inductor. Thus, the current is zero immediately after $t = 0$, and

$$0 = A + \frac{E}{R}$$

$$\text{and } i = \frac{E}{R}(1 - \epsilon^{-Rt/L}) \quad (6-5)$$

This response is plotted in Fig. 6-10, and we can see the manner in which the current builds up from its initial value of zero to its final value of E/R . The transition is effectively accomplished in about 3τ sec. If our circuit represents the field coil of a large d-c motor, we might assign $L = 10$ henrys and $R = 20$ ohms, obtaining $\tau = 0.5$ sec. The field current is thus established in about 1.5 sec. In one time constant, the current has attained 63.2 per cent of its final value.

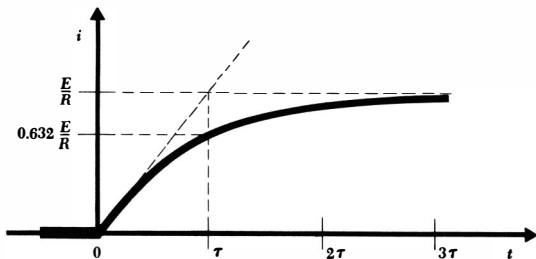

Fig. 6-10 The current expressed by Eq. (6-5) is shown graphically. A line extending the initial slope meets the constant forced current at $t = \tau$.

Now let us apply this method to a more complicated circuit. In Fig. 6-11, there is shown a circuit containing a d-c voltage source as well as a step-voltage source. Let us determine $i(t)$ for all values of time. We might choose to replace everything to the left of the inductor by the Thévenin equivalent, but instead let us merely recognize the form of that equivalent as a resistor in series with some voltage source. The circuit contains only one energy-storage element, the inductor, and the natural response is therefore a negative exponential as before,

$$i = i_f + i_n$$

where

$$i_n = A e^{-t/\tau} \quad t > 0$$

since

$$\tau = \frac{L}{R_{eq}} = \frac{3}{1.5} = 2$$

The forced response must be that produced by a constant voltage of 100 volts. The forced response is constant, and no voltage is present across the inductor; it behaves as a short circuit and, therefore,

$$i_f = \frac{100}{2} = 50$$

Thus,

$$i = 50 + A e^{-0.5t} \quad t > 0$$

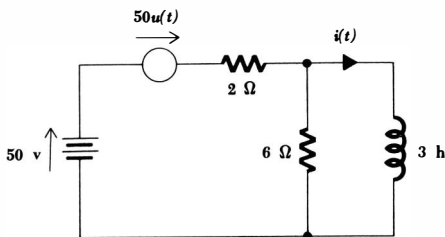

Fig. 6-11 A circuit used as an example.

186 **The Transient Circuit**

In order to evaluate A , we must establish the initial value of the inductor current. Prior to $t = 0$, this current is 25 amp, and it cannot change instantaneously. Thus,

$$25 = 50 + A \quad \text{or} \quad A = -25$$

Hence,

$$i = 50 - 25\epsilon^{-0.5t} \quad t > 0$$

We complete the solution by also stating

$$i = 25 \quad t < 0$$

and the complete response is sketched in Fig. 6-12. Note how the natural response serves to connect the response for $t < 0$ with the constant forced response.

As a final example of this method by which the complete response of any circuit subjected to a transient may be written down almost by inspection, let us apply a rectangular voltage pulse, E volts high and t_0 sec wide, to the simple RL series circuit. We represent the forcing function as the sum of two step-voltage sources $Eu(t)$ and $-Eu(t - t_0)$, as indicated in Fig. 6-13a and b, and plan to obtain the response by using the superposition principle. Suppose we designate that part of $i(t)$ which is due to the upper source $Eu(t)$ acting alone by the symbol $i_1(t)$ and then let $i_2(t)$ represent that part due to $-Eu(t - t_0)$ acting alone. Then,

$$i(t) = i_1(t) + i_2(t)$$

Our object is now to write each of the partial responses i_1 and i_2 as the sum of a natural and a forced response. The response $i_1(t)$ is familiar; this problem was solved two or three pages back,

$$i_1(t) = \frac{E}{R}(1 - \epsilon^{-Rt/L}) \quad t > 0$$

Fig. 6-12 The response $i(t)$ of the circuit shown in Fig. 6-11 is sketched for values of time less and greater than zero.

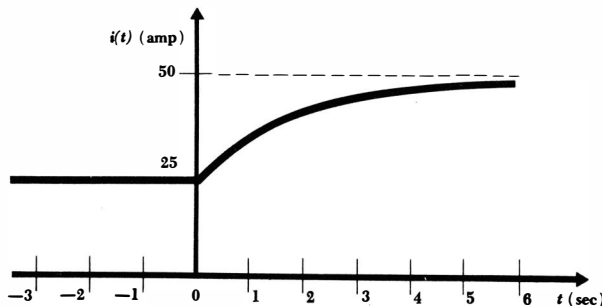

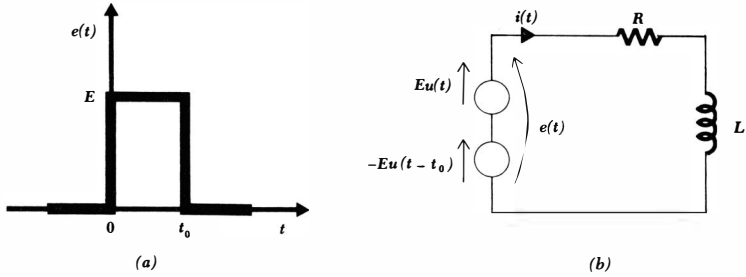

Fig. 6-13 (a) A rectangular voltage pulse which is to be used as the forcing function in a simple series RL circuit. (b) The series RL circuit, showing the representation of the forcing function by the series combination of two ideal voltage-step sources. The current $i(t)$ is desired.

Note that the range of t , $t > 0$, in which this solution is valid, is indicated.

We now turn our attention to the lower source and its response $i_2(t)$. Only the polarity of the source and the time of its application are different. There is thus no need to determine the form of the natural response and the forced response; the solution for $i_1(t)$ enables us to write

$$i_2(t) = -\frac{E}{R} (1 - \epsilon^{-R(t-t_0)/L}) \quad t > t_0$$

where the applicable range of t , $t > t_0$, must again be indicated.

We now add the two solutions, but do so carefully, since each is valid over a different interval of time. Thus,

$$i(t) = \frac{E}{R} (1 - \epsilon^{-Rt/L}) \quad 0 < t < t_0$$

$$i(t) = \frac{E}{R} (1 - \epsilon^{-Rt/L}) - \frac{E}{R} (1 - \epsilon^{-R(t-t_0)/L}) \quad t > t_0$$

or
$$i(t) = \frac{E}{R} \epsilon^{-Rt/L} (\epsilon^{Rt_0/L} - 1) \quad t > t_0$$

The solution is completed by stating that $i(t)$ is zero for negative t and sketching the response as a function of time. The type of curve obtained depends upon the relative values of t_0 and the time constant τ . Two possible curves are shown in Fig. 6-14. The left curve is drawn for the case where the time constant is only one-half as large as the length of the applied pulse; the rising portion of the exponential has therefore almost reached E/R before the decaying exponential begins. The opposite situation is shown to the right; there, the time constant is twice t_0 and the response never has a chance to reach the larger amplitudes.

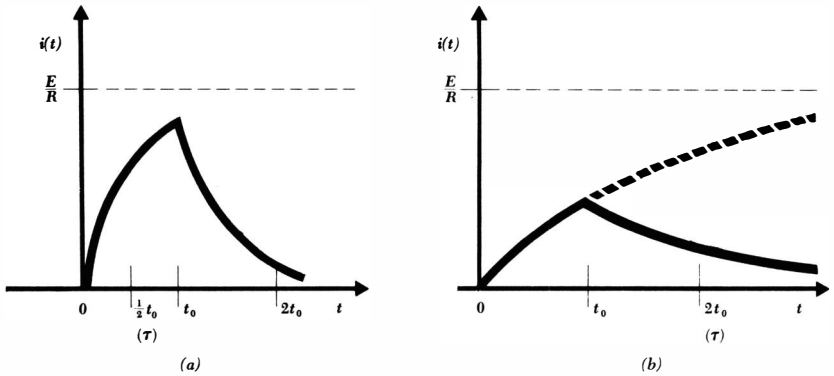

Fig. 6-14 Two possible response curves are shown for the circuit of Fig. 6-13b. In (a), τ is selected as $t_0/2$, and in (b) as $2t_0$.

Drill Problems

6-5 Find the forced portion of the response $i(t)$ for the circuits of Fig. 6-15a, b, and c.

Ans. 14 amp; 40 amp; -0.5 amp

6-6 Find the value of $i(0^+)$ for the circuits of Fig. 6-15a, b, and c.

Ans. 1 amp; 2 amp; 10 amp

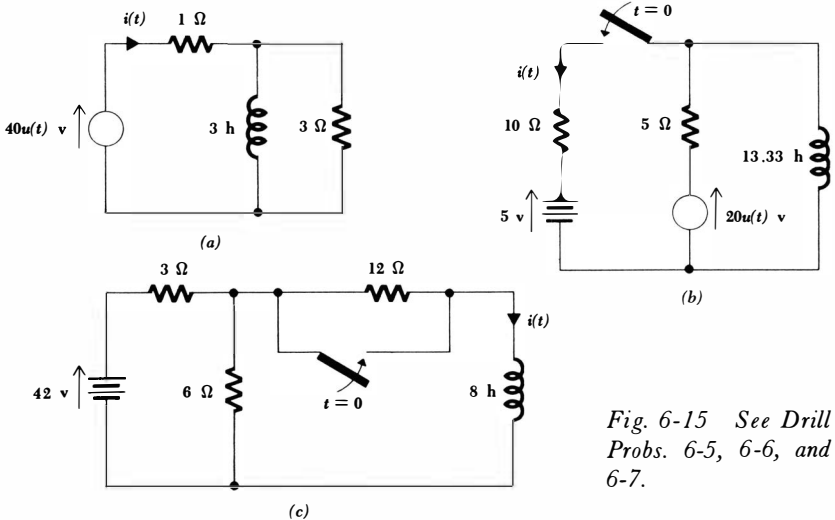

Fig. 6-15 See Drill Probs. 6-5, 6-6, and 6-7.

189 The Application of the Unit-step Forcing Function

6-7 Find $i(t)$ for $t > 0$ for the circuits of Fig. 6-15a, b, and c.

Ans. $14 - 12\epsilon^{-t/4}$ amp; $40 - 30\epsilon^{-t/4}$ amp; $-0.5 + 1.5\epsilon^{-t/4}$ amp

6-6 RC CIRCUITS

The complete response of any RC circuit may also be obtained as the sum of the natural and the forced response. We shall consider two examples, one representing a fairly general problem and the other representing those circuits in which a trapped voltage may be present.

Let us first consider the circuit shown in Fig. 6-16. The switch is assumed to have been in position "a" for a long time, or, in other words, the natural response which resulted from the original excitation of the circuit has decayed to a negligible amplitude, leaving only a forced response caused by the 120-volt battery. We are asked for $e_C(t)$, and we thus begin by finding this forced response when the switch is in position "a." The voltages throughout the circuit are all constant, and there is thus no current through the capacitor. Simple voltage division determines the forced response prior to $t = 0$,

$$e_{Cf} = \frac{50}{50 + 10} 120 = 100 \quad t < 0$$

and we thus have the initial condition

$$e_C(0) = 100$$

Since the capacitor voltage cannot change instantaneously, this voltage is equally valid at $t = 0^-$ and $t = 0^+$.

The switch is now thrown to "b," and the complete response is

$$e_C = e_{Cf} + e_{Cn}$$

The form of the natural response is obtained by replacing the 50-volt battery by a short circuit and evaluating the equivalent resistance,

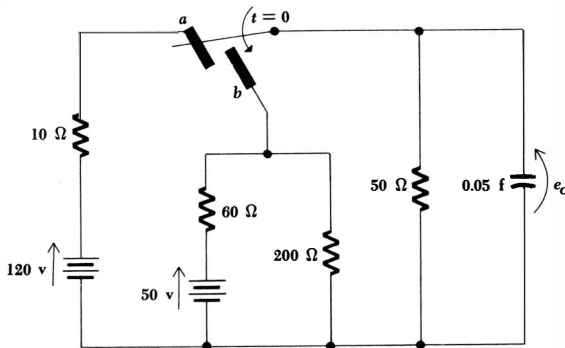

Fig. 6-16 An RC circuit in which the complete response e_C is obtained by adding a forced response and a natural response.

190 *The Transient Circuit*

$$e_{Cn} = A\epsilon^{-t/R_{eq}C}$$

$$R_{eq} = \frac{1}{\frac{1}{50} + \frac{1}{200} + \frac{1}{60}} = 24$$

or $e_{Cn} = A\epsilon^{-t/1.2}$

In order to evaluate the forced response with the switch at “b,” we wait until all the voltages and currents have stopped changing, thus treating the capacitor as an open circuit, and use voltage-division once more,

$$e_{cf} = \frac{(50)(200)/(50 + 200)}{60 + (50)(200)/(50 + 200)} 50 = 20$$

Thus,

$$e_C = 20 + A\epsilon^{-t/1.2}$$

and from the initial condition already obtained,

$$100 = 20 + A$$

or $e_C = 20 + 80\epsilon^{-t/1.2} \quad t > 0$

This response is sketched in Fig. 6-17; again the natural response is seen to form a transition from the initial to the final response.

Let us now consider the circuit which is shown in Fig. 6-18*a*. In order to simplify the drawing, two switches are not shown; these switches are thrown at $t = 0$ to change the configuration of the circuit to that shown in Fig. 6-18*b*. We shall assume that the curved lines on the capacitor symbols represent the same capacitor plates in each circuit. Circuits operating on this principle, but containing hundreds or thousands of capacitors, are sometimes used to provide large voltages from lower-voltage sources to test high-voltage insulation. After $t = 0$, it should be noted that the presence of two capacitors in series is a warning that a trapped voltage is probably present. We desire the responses e_1 and e_2 , but we must begin by treating the two capacitors as a single element. Thus we first find $e(t)$.

Fig. 6-17 The response of the circuit of Fig. 6-16 is plotted as a function of time.

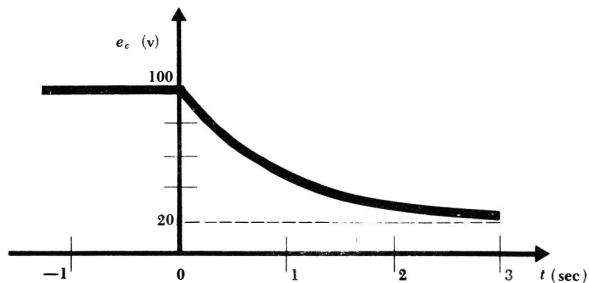

191 *The Application of the Unit-step Forcing Function*

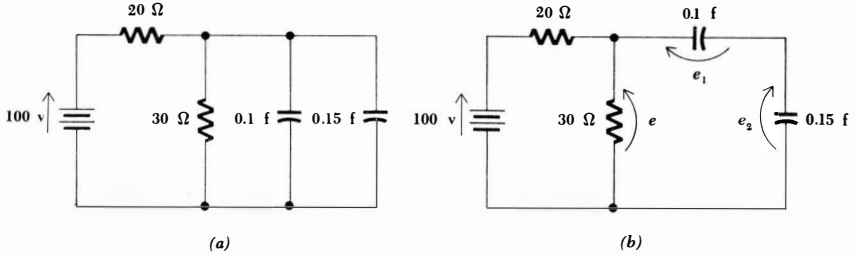

Fig. 6-18 Two switches, which are not shown, are thrown at $t = 0$ to convert the circuit shown in (a) to that in (b).

Representing e by the sum of a natural and forced response, we easily obtain the forced response of the right-hand circuit,

$$e_f = 60$$

and let the natural response be

$$e_n = A\epsilon^{-t/\tau}$$

where

$$\tau = R_{eq}C_{eq} = \frac{(20)(30)}{20 + 30} \frac{(0.1)(0.15)}{0.1 + 0.15} = 12(0.06) = 0.72$$

Thus,

$$e = 60 + A\epsilon^{-t/0.72}$$

The initial value of $e(t)$ must be determined from the previous history of the circuit as shown in Fig. 6-18a. Each capacitor is originally charged to 60 volts, and this voltage cannot change during the switching operation. The two capacitor voltages are additive after $t = 0$, and thus

$$e(0) = 120$$

Hence,

$$A = 60$$

and
$$e = 60 + 60\epsilon^{-t/0.72} \quad t > 0$$

In order to find e_1 or e_2 , we must proceed by a step-by-step process. The current entering the left terminal of the 0.1-farad capacitor is

$$i = C_{eq} \frac{de}{dt} = 0.06(60) \left(-\frac{1}{0.72} \right) \epsilon^{-t/0.72} = -5\epsilon^{-t/0.72}$$

Knowing the current, we may find e_1 ,

$$\begin{aligned} e_1 &= \frac{1}{0.1} \int i dt + k_1 \\ &= 10(-5)(-0.72)\epsilon^{-t/0.72} + k_1 \\ &= 36\epsilon^{-t/0.72} + k_1 \end{aligned}$$

192 **The Transient Circuit**

Since the initial value of e_1 is 60 volts,

$$e_1 = 24 + 36e^{-t/0.72} \quad t > 0$$

and thus

$$e_2 = 36 + 24e^{-t/0.72} \quad t > 0$$

We have found $e(t)$ as the sum of a natural and a forced response. The voltages e_1 and e_2 might have been determined in the same way, although we should have had to remember to add the necessary constant to the natural response in each case. It is usually easier to obtain the voltage across the equivalent capacitor first, proceeding then to the interior of the capacitive network by simple steps.

Drill Problems

6-8 Find the forced portion of the response $e(t)$ for the circuits of Fig. 6-19a, b, and c.

Ans. -1 volt; 28 volts; 80 volts

6-9 Find the value of $e(0^+)$ for the circuits of Fig. 6-19a, b, and c.

Ans. 20 volts; 4 volts; 2 volts

6-10 Find $e(t)$ for $t > 0$ for the circuits of Fig. 6-19a, b, and c.

Ans. $-1 + 3e^{-t/4}$ volts; $80 - 60e^{-t/4}$ volts; $28 - 24e^{-t/4}$ volts

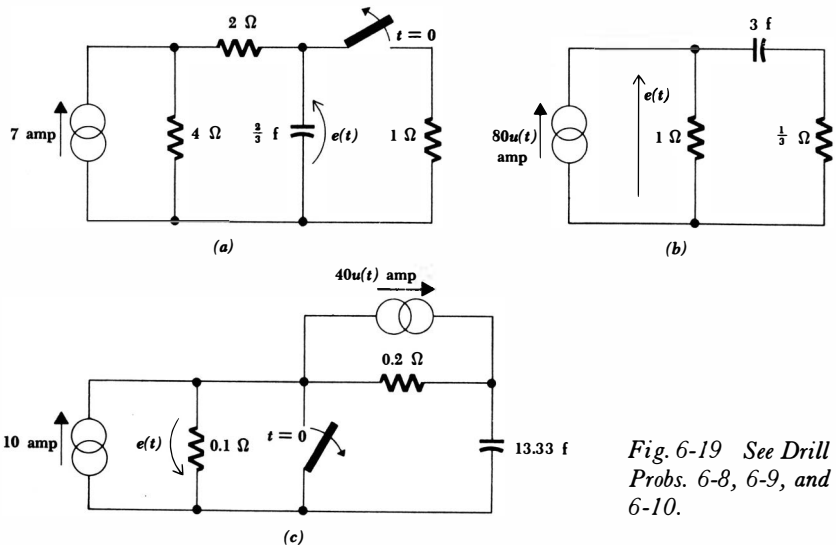

Fig. 6-19 See Drill Probs. 6-8, 6-9, and 6-10.

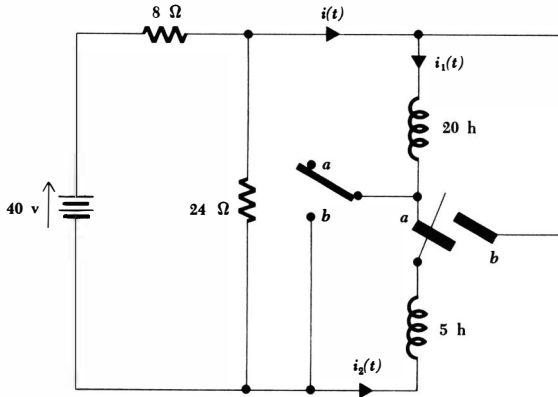

Fig. 6-20 See Drill Prob. 6-11.

6-11 The circuit of Fig. 6-20 has been in the state shown for a very long time. At $t = 0$, both switches are thrown from “a” to “b.” For $t > 0$, find: (a) $i(t)$; (b) $i_1(t)$; (c) $i_2(t)$.

Ans. $4 + \epsilon^{-1.5t}$ volts; $-1 - 4\epsilon^{-1.5t}$ volts; $5 + 5\epsilon^{-1.5t}$ volts

Problems

- 1 Make sketches of the following forcing functions as functions of time:
 - (a) $e(t) = 3u(t + 2)$ (b) $i(t) = -2u(t + 3)$
 - (c) $i(t) = u(t) + u(t - 1) + u(t - 2) + \dots = \sum_{n=0}^{\infty} u(t - n)$
 - (d) $e(t) = u(t - 1) - u(t - 3)$ (e) $e(t) = [u(t - 1)][u(t - 3)]$
 - (f) $i(t) = 10[u(t) - u(t - 1)] \cos 5\pi t$ (g) $i(t) = 5u(t)(1 - \epsilon^{-4t})$
- ◆2 Draw a circuit containing one single-pole switch and a d-c source which is the exact equivalent of the circuit shown in Fig. 6-4a.
- 3 If the networks within the boxes of Fig. 6-21a to f are known to be passive and to be without energy storage prior to the first switching operation, and if the switches have been in the position shown for a long time, replace the batteries, d-c sources, and switches in each circuit by a suitable arrangement of voltage- or current-step forcing functions which will provide an identical response within the passive network for all time.
- ◆4 Find $i(t)$ in the circuit of Fig. 6-22a by making use of Thévenin’s theorem. Sketch the resultant current.
- 5 For the circuit of Fig. 6-22b, write the differential equation which is appropriate for $t > 0$, separate the variables, and then integrate. Obtain $e(t)$ in terms of I , R , and C . Sketch the response for $t < 0$ and $t > 0$ if $I = 10$ ma, $R = 2$ kilohms, and $C = 50$ pf.

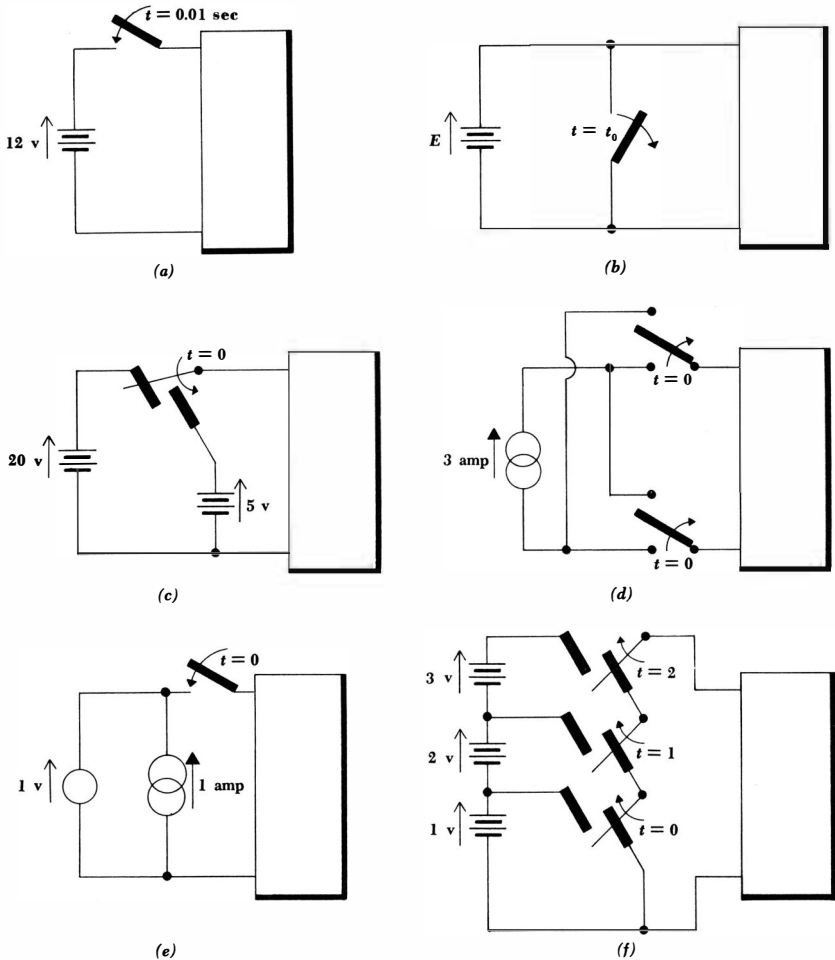

Fig. 6-21 See Prob. 3.

- ◆6 A capacitor C is in parallel with a nonlinear “square-law” resistive element, as exemplified by several semiconductor diodes at low voltages. Assume that this passive element satisfies the relationship $i = ke^2$, where k is a positive constant. (a) Write the differential equation for this two-element circuit. (b) Separate the variables and solve the equation subject to the condition $e(t) = e_0$ at $t = 0$. (c) Sketch the response $e(t)$ as a function of time and compare with the response curve obtained for a normal resistor.
- 7 Include a parallel unit-step current source in the circuit described in Prob. 6, determine the correct initial condition, and find $e(t)$.
- ◆8 Solve Prob. 6 if the capacitor is replaced by an inductor L .

195 *The Application of the Unit-step Forcing Function*

- 9 Solve Prob. 7 if the capacitor is replaced by an inductor L .
- ▶10 Find and sketch the battery current $i(t)$ in the circuit of Fig. 6-23a. Include the range $t < 0$.
- ▶11 Find and sketch $i(t)$ for $-1 \leq t \leq 5$ in the circuit shown in Fig. 6-23b.
- 12 In each of the circuits shown in Fig. 6-24, the switch has been in position "a" for a long time. At $t = 0$ it is thrown from "a" to "b." Find and sketch $i(t)$.
- 13 Draw an equivalent circuit for Fig. 6-24a which does not contain any switches.
- ▶14 Find and sketch $i(t)$ in the circuit of Fig. 6-25a for $t < 0$ and $t > 0$.
- 15 The switch in the circuit of Fig. 6-25b has been at "a" for a long time. At $t = 0$ it is thrown to "b." (a) Find and sketch $i_L(t)$ for $t < 0$ and $t > 0$. (b) Determine $i_x(t)$ for $t < 0$, $t = 0$, and $t > 0$.
- ▶16 The left switch in the circuit shown in Fig. 6-26a is closed at $t = -0.5$ sec, and the right switch is closed at $t = 0$. Find $i_1(t)$ and $i_2(t)$.
- 17 Use superposition to determine the current flowing downward in the inductor in the circuit of Fig. 6-26b. How much energy is stored in the inductor at $t = \infty$?
- ▶18 Find and sketch $e_x(t)$ in the circuit of Fig. 6-27a.
- 19 In the circuit shown in Fig. 6-27b, the switch has been at "a" sufficiently long that the circuit has assumed the forced response. At $t = 0$ the switch

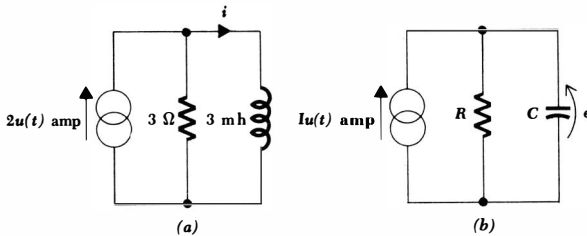
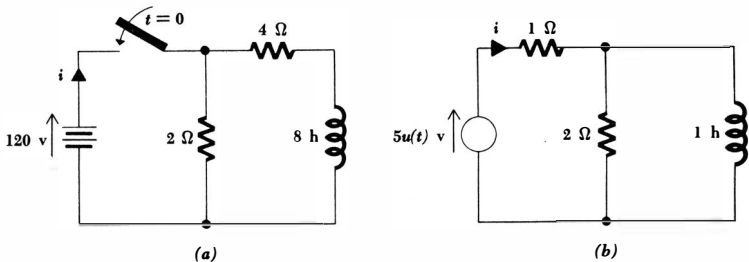
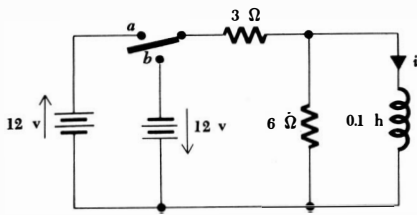

Fig. 6-22 (a) See Prob. 4. (b) See Prob. 5.

Fig. 6-23 (a) See Prob. 10. (b) See Prob. 11.





(a)

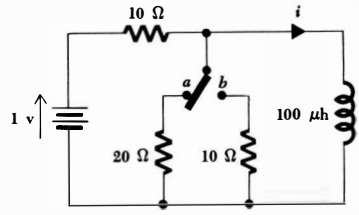

(b)

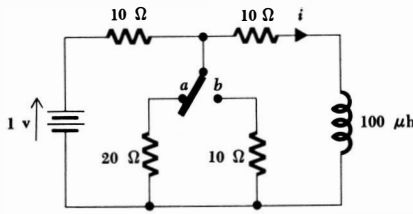

(c)

Fig. 6-24 See Probs. 12 and 13.

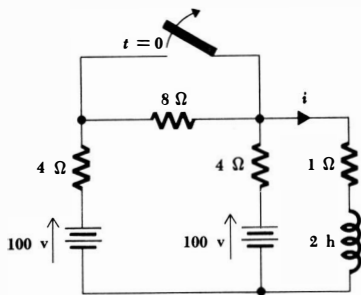

(a)

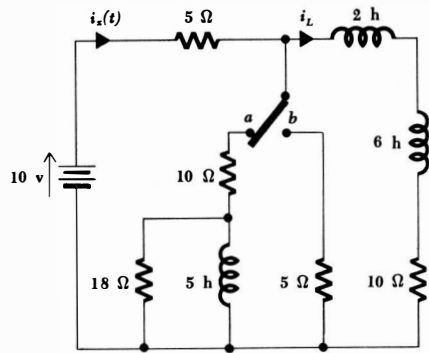

(b)

Fig. 6-25 (a) See Prob. 14. (b) See Prob. 15.

Fig. 6-26 (a) See Prob. 16. (b) See Prob. 17.

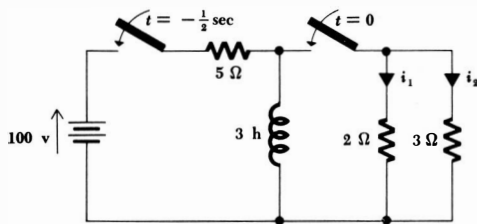

(a)

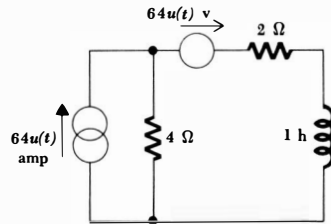

(b)

197 **The Application of the Unit-step Forcing Function**

- is thrown to “b.” (a) Find $i(t)$. (b) Determine the energy delivered to the 2-ohm resistor during the first 1-sec interval after $t = 0$.
- 20 If the values of E/R and t_0 are the same in the response curves drawn in Fig. 6-14a and b, how may the parameters of the circuit of Fig. 6-13b be changed to produce the two different response curves?
- ◆21 Find $i(t)$ for the circuit shown in Fig. 6-28a if: (a) $E = 100$ volts, $R = 10$ kilohms, $C = 100$ pf; (b) $E = 1$ volt, $i(0^+) = 1$ ma, $\left. \frac{de_C}{dt} \right|_{0^+} = 10$ volts/sec.
- 22 If a circuit containing switches can be replaced by an equivalent containing only singularity functions which is valid for all time, then superposition, Thévenin’s theorem, Norton’s theorem, and source transformations may be made directly. This is true because the circuit now contains only linear passive elements and forcing functions (no switches, which are really time-varying elements). Redraw the circuit of Fig. 6-28b in such a way that the switch is eliminated, and then determine $e_C(t)$ by about five different methods.
- ◆23 Find $e_C(t)$ if $e_C(0) = 75$ volts in the circuit shown in Fig. 6-29a.

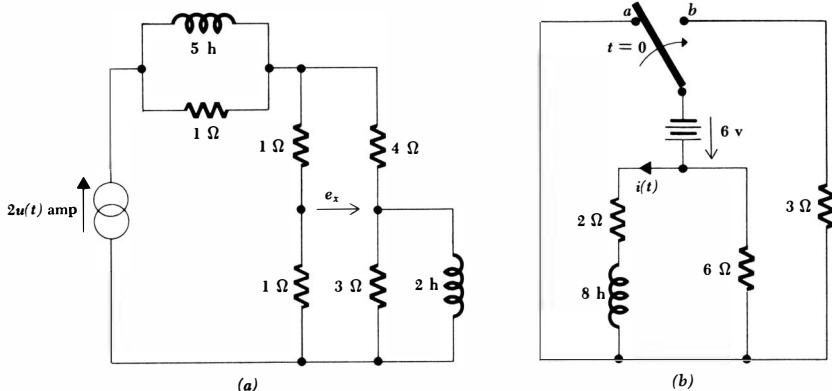
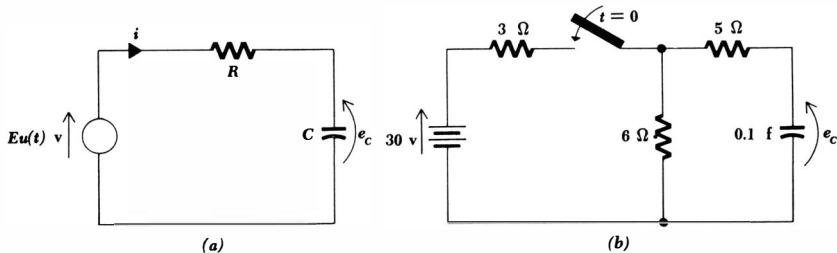

Fig. 6-27 (a) See Prob. 18. (b) See Prob. 19.

Fig. 6-28 (a) See Prob. 21. (b) See Prob. 22.



- 24 In the circuit shown in Fig. 6-29b, both capacitors are uncharged at $t = 0$. (a) Write the mesh equations for the network. (b) Find $i_1(0^+)$ and $i_2(0^+)$.
- 25 (a) Show that the mere replacement of the 30-volt source and switch in the circuit of Fig. 6-29c by a 30-volt step-voltage source does not yield an equivalent which is correct for all time. (b) Show, however, that this equivalent is correct for $t > 0$ if a suitable initial condition is forced on the capacitor by placing a battery in parallel with it which is removed at $t = 0$. The circuit still contains a switch, but it should be noted that the switch is very easily taken into account. (c) Show that the replacement of the switch by the voltage source $18 - 18u(t)$ volts produces a "switchless" equivalent.

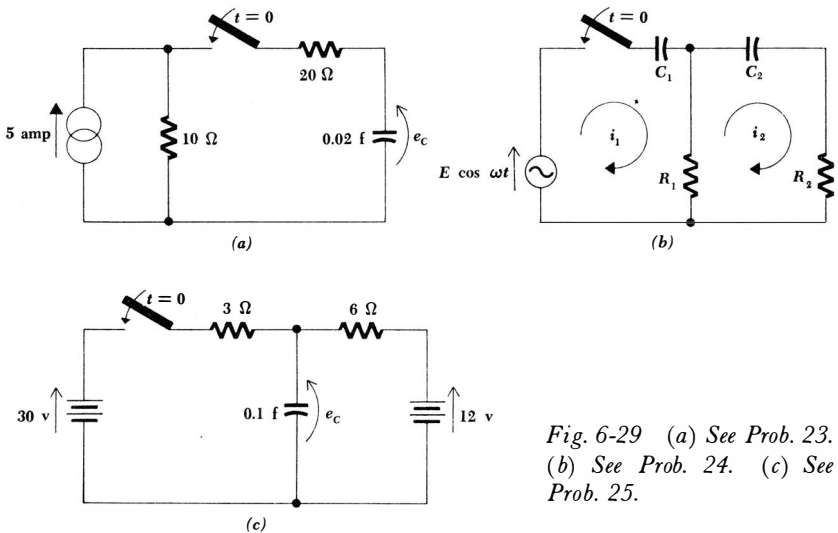
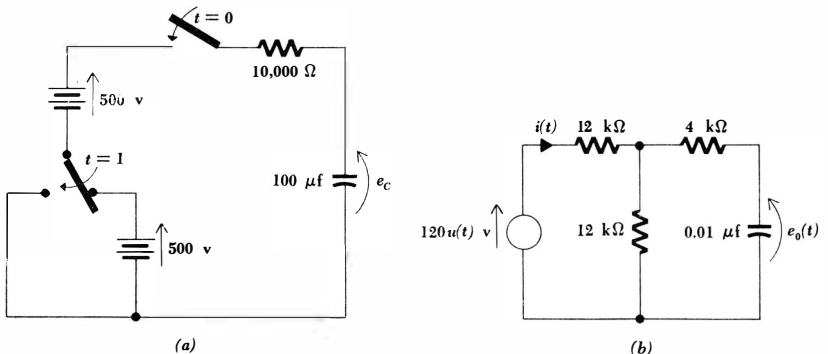

Fig. 6-29 (a) See Prob. 23. (b) See Prob. 24. (c) See Prob. 25.

Fig. 6-30 (a) See Prob. 26. (b) See Prob. 27.



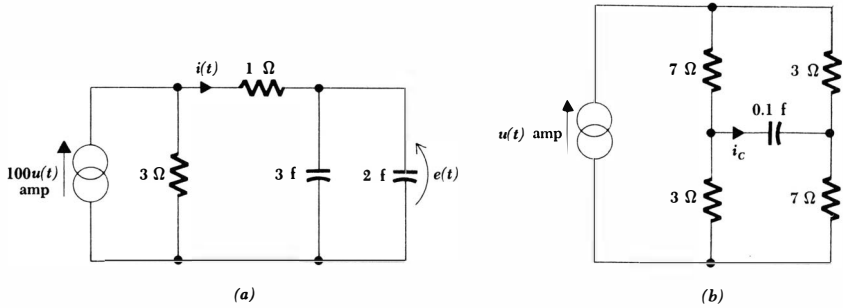
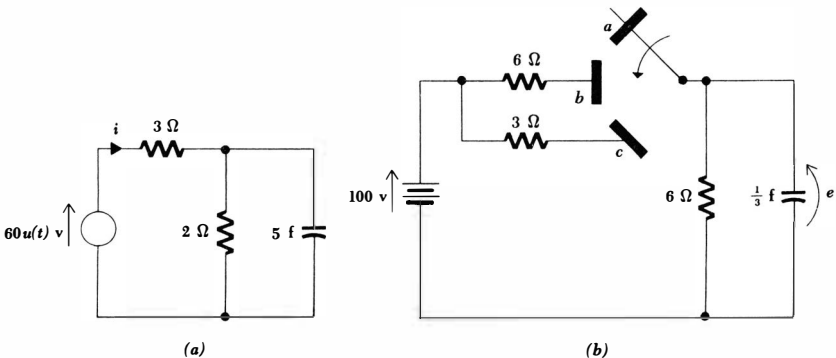

Fig. 6-31 (a) See Prob. 28. (b) See Prob. 29.

- ◆26 In the circuit shown in Fig. 6-30a, one switch is thrown at $t = 0$ and the other at $t = 1$ sec, as indicated. Find and sketch $e_C(t)$ over the interesting time interval.
- 27 Determine $e_0(t)$ and $i(t)$ for the circuit shown in Fig. 6-30b. Plot each response as a function of time, indicating the value of the time constant and important amplitudes.
- ◆28 Find and sketch $e(t)$ and $i(t)$ for the circuit of Fig. 6-31a.
- 29 (a) Find $i_C(t)$ for $t > 0$ in the circuit of Fig. 6-31b. (b) Compute the energy stored in this capacitor at $t = (\ln 2)/2$.
- ◆30 A voltage source which is zero for $t < 0$, 10 volts for $0 < t < 1$, and zero for $t > 1$ is placed in series with a 1-ohm resistor and a 1-farad capacitor. Determine the capacitor voltage for $t < 0$ and $t > 0$.
- 31 The response of a circuit to a square-wave forcing function may be determined by the procedure described below. Assume that a square-wave forcing function, a resistance R , and a capacitance C are in series. At $t = 0$, the capacitor is charged to e_0 volts, and the forcing function is E volts. The forcing function remains at a constant E volts until $t = T/2$,

Fig. 6-32 (a) See Prob. 32. (b) See Prob. 33.



- at which time it suddenly becomes zero. (a) Let the capacitor voltage be e_1 at $t = T/2$. Find e_1 in terms of e_0 , E , T , R , and C . (b) The forcing function is zero until $t = T$, at which instant it becomes E volts again. Let the capacitor voltage be e_2 at $t = T$. Find e_2 in terms of e_0 , E , T , R , and C . (c) The forcing function is alternately zero and E for intervals of $T/2$ sec. After this cycle has proceeded for a long time, it is evident that e_2 and e_0 will be identical. Determine e_2 ($= e_0$) in terms of E , T , R , and C . (d) Determine e_1 in terms of e_0 and E . (e) Sketch the capacitor voltage as a function of time for this condition if $T = \tau/3$ and then if $T = 3\tau$.
- 32 (a) Find $i(t)$ for the circuit of Fig. 6-32a by combining the forced and natural responses. (b) Use Norton's theorem to simplify the source and determine $i(t)$ again.
- ◆33 The switch in Fig. 6-32b has been at "a" for a long time. At $t = 0$ it is connected to "b"; at $t = 1$ sec it is thrown to "c." Find e at $t = 2$ sec.

Chapter **7** *The Unit Impulse and Its Applications*

7-1 INTRODUCTION

In this chapter we shall define the unit impulse and interpret it from several different viewpoints. From one viewpoint, the impulse is a satisfactory model for a very short, large-amplitude pulse, such as the pulse which is initially applied to the horizontal deflection coil of a television receiver to provide a sweep which is initially linear at the left edge of the screen; the output of a blocking oscillator, which may be several hundred volts in amplitude and a few tenths of a microsecond in duration, may also be closely approximated by an impulse.

However, the most important applications of the impulse are probably those which are of a more theoretical nature. We shall consider its use in replacing initial conditions on every energy-storage element within the circuit to be analyzed, and we shall also see how it is a necessary part of the response in many highly idealized circuits to which a unit step is applied as a forcing function. For example, the current response when an ideal battery is suddenly connected across an uncharged (ideal) capacitor turns out to be an impulse. Other important applications of the unit impulse arise when operational methods are applied to circuit analysis and synthesis, but these applications are outside the scope of this introductory study.

This chapter may be omitted without any appreciable loss in continuity. The impulse is occasionally mentioned in a qualitative manner in the following chapters, but detailed knowledge of its characteristics is required only in certain special groups of problems.

7-2 DEFINITION OF THE UNIT IMPULSE

In Chap. 4 the definition of inductance was illustrated by determining the inductor voltage for a current having a trapezoidal waveshape; the current was initially zero; it then rose linearly to a constant value which it maintained for a finite time, finally dropping linearly to zero once more. As the time required

for the linear rise and fall was allowed to approach zero, the inductor voltage was found to contain positive and negative pulses of large amplitude and short duration; in the limit, positive and negative spikes were obtained which we then called "impulses," although we did not define the term carefully. Let us now do so.

We shall define the unit impulse as a function of time which is zero when its argument, generally $(t - t_0)$, is less than zero; which is also zero when its argument is greater than zero; which is infinite when its argument is zero; and which has unit area. Mathematically, the defining statements are

$$\delta(t - t_0) = 0 \quad t \neq t_0 \quad (7-1)$$

$$\text{and} \quad \int_{-\infty}^{\infty} \delta(t - t_0) dt = 1 \quad (7-2)$$

where the symbol δ ("curly" delta) is used to represent the unit impulse. In view of the functional values expressed by Eq. (7-1), it is apparent that the limits on the integral in Eq. (7-2) may be any values which are less than t_0 and greater than t_0 . In particular, we may let t_0^- and t_0^+ represent values of time which are arbitrarily close to t_0 and then express Eq. (7-2) as

$$\int_{t_0^-}^{t_0^+} \delta(t - t_0) dt = 1 \quad (7-3)$$

For the most part, we shall concern ourselves with circuits having only a single discontinuity, and we shall select our time scale so that the switching operation occurs at $t = 0$. For this special case, the defining equations are

$$\delta(t) = 0 \quad t \neq 0 \quad (7-4)$$

$$\text{and} \quad \int_{-\infty}^{\infty} \delta(t) dt = 1 \quad (7-5)$$

$$\text{or} \quad \int_{0^-}^{0^+} \delta(t) dt = 1 \quad (7-6)$$

The unit impulse may be multiplied by a constant also; this cannot, of course, affect Eq. (7-1) or (7-4), because the value must still be zero when the argument

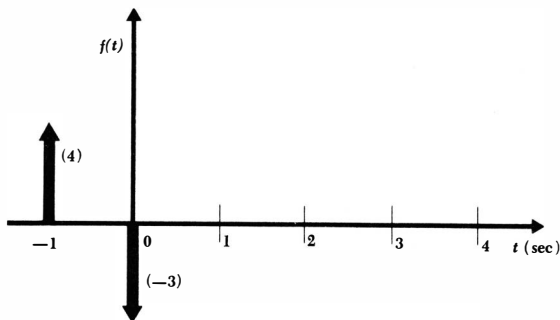

Fig. 7-1 A positive and negative impulse are plotted graphically as functions of time. The strengths of the impulses are 4 and -3 , respectively.

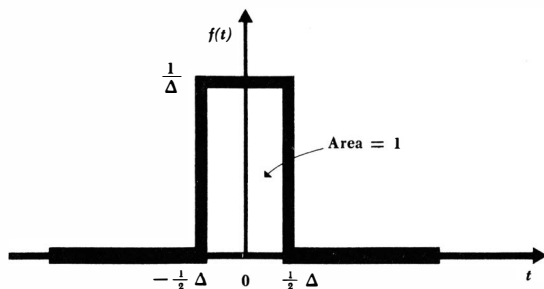

Fig. 7-2 A rectangular pulse of unit area which approaches a unit impulse as $\Delta \rightarrow 0$.

is zero. However, multiplication of any of the integral expressions by a constant shows that the area under the impulse is now equal to the constant multiplying factor; this area is called the *strength* of the impulse. Thus, the impulse $5\delta(t)$ has a strength of 5, and the impulse $-10\delta(t-2)$ has a strength of -10 . If the unit impulse is multiplied by a function of time, then the strength of the impulse must be the value of that function at the time for which the impulse *argument* is zero. In other words, the strength of the impulse $e^{-t/2}\delta(t-2)$ is 0.368, and the strength of the impulse $\sin(5\pi t + \pi/4)\delta(t)$ is 0.707. It is therefore possible to write the following integrals¹ which make the same statement in mathematical form:

$$\int_{-\infty}^{\infty} f(t) \delta(t) dt = f(0) \quad (7-7)$$

or
$$\int_{-\infty}^{\infty} f(t) \delta(t - t_0) dt = f(t_0) \quad (7-8)$$

The graphical symbol for an impulse is shown in Fig. 7-1, where $f(t) = 4\delta(t+1) - 3\delta(t)$ is plotted as a function of time. It is customary to indicate the strength of the impulse in parentheses adjacent to the impulse. Note that no attempt should be made to indicate the strength of an impulse by adjusting its amplitude; each spike has infinite amplitude, and all impulses should be drawn with the same convenient amplitude. Positive and negative impulses should be drawn above and below the time axis, respectively. In order to avoid confusion with the ordinate, the lines and arrows used to form the impulses are drawn thicker than are the axes.

We shall find it convenient to be familiar with several other interpretations of the unit impulse. We seek graphical forms which do not have infinite amplitudes, but which will approximate an impulse as the amplitude increases. Let us first consider a rectangular pulse, such as that shown in Fig. 7-2. The pulse width is selected as Δ sec and its amplitude as $1/\Delta$, thus forcing the area of the pulse to be unity, regardless of the magnitude of Δ . As Δ decreases, the amplitude $1/\Delta$ increases, and the rectangular pulse becomes a better approximation to a unit impulse. The response of a circuit element to a unit impulse may be

¹ They are called *sifting integrals* because the integral sifts out a particular value of $f(t)$.

determined by finding its response to this rectangular pulse and then letting Δ approach zero. However, since the impulse response is easily found, we should also realize that this response may in itself be an acceptable approximation to the response produced by a short rectangular pulse.

A triangular pulse, sketched in Fig. 7-3, may also be used to approximate the unit impulse. Since we again prefer unit area, a pulse of amplitude $1/\Delta$ must possess an overall width of 2Δ sec. As Δ approaches zero, the triangular pulse approaches the unit impulse. There are many other pulse shapes which, in the limit, approach the unit impulse, but we shall take the negative exponential as our last limiting form. We first construct such a waveform with unit area by finding the area under the general exponential,

$$f(t) = \begin{cases} 0 & t < 0 \\ A\epsilon^{-t/\tau} & t > 0 \end{cases}$$

or $f(t) = A\epsilon^{-t/\tau} u(t)$

Thus

$$\text{Area} = \int_0^{\infty} A\epsilon^{-t/\tau} dt = -\tau A\epsilon^{-t/\tau} \Big|_0^{\infty} = \tau A$$

and we thus must set $A = 1/\tau$. The time constant will be very short, and we shall again use Δ to represent this short time. Thus, the exponential function

$$f(t) = \frac{1}{\Delta} \epsilon^{-t/\Delta} u(t)$$

approaches the unit impulse as $\Delta \rightarrow 0$. This representation of the unit impulse indicates that the exponential decay of a current or voltage in a circuit approaches an impulse (but not necessarily a unit impulse) as the time constant is reduced.

For our final interpretation of the unit impulse, let us try to establish a relationship with the unit-step function. The function shown in Fig. 7-4a is almost a unit step; however, Δ sec is required for it to complete the linear change from zero to unit amplitude. Beneath this modified unit-step function, Fig. 7-4b

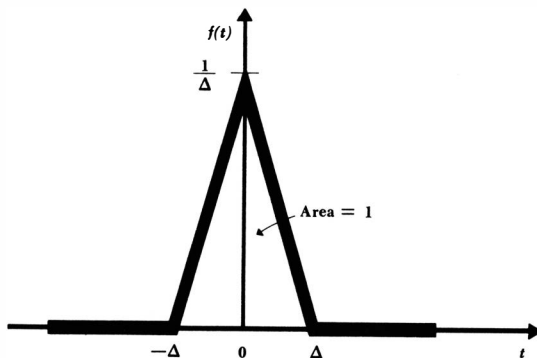

Fig. 7-3 A triangular pulse of unit area which approaches a unit impulse as $\Delta \rightarrow 0$.

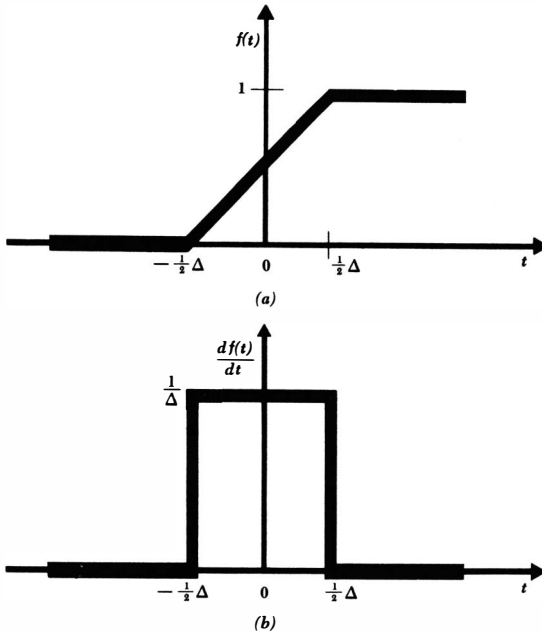

Fig. 7-4 (a) A modified unit-step function; the transition from zero to unity is linear over a Δ -sec time interval. (b) The derivative of the modified unit step. As $\Delta \rightarrow 0$, (a) becomes the unit step and (b) approaches the unit impulse.

shows its derivative; since the linear portion of the modified step rises at the rate of 1 unit every Δ sec, the derivative must be a rectangular pulse of amplitude $1/\Delta$ and width Δ . This, however, was the first function we considered as an approximation to the unit impulse, and we know that it approaches the unit impulse as Δ approaches zero. But the modified unit step approaches the unit step itself as Δ approaches zero, and we conclude that the unit impulse may be regarded as the time derivative of the unit-step function.² Mathematically,

$$\delta(t) = \frac{du(t)}{dt} \tag{7-9}$$

and conversely,

$$u(t) = \int_0^t \delta(t) dt \tag{7-10}$$

where the lower limit may in general be any value of t less than zero. Either Eq. (7-9) or (7-10) could be used as the definition of the unit impulse if we wished.

We thus see another method suggesting itself for the determination of the response to a unit impulse. If we can find the unit-step response, then the linear nature of our circuits requires the response to a unit impulse to be the derivative

² The fact that the derivative of the unit step does not exist at the point of the discontinuity creates quite a skeptical attitude in many mathematicians; nevertheless, the impulse is a useful analytical function.

of the response to the unit step. From the opposite point of view, if the response to a unit impulse is known, then the integral of this response must be the unit-step response.

Drill Problems

7-1 A 0.01- μf capacitor is connected to a current source having an output which is a rectangular pulse of 1 msec duration and 10 ma amplitude. (a) Find the magnitude of the capacitor voltage 1 sec after the pulse begins. (b) Repeat if the duration of the pulse is reduced to 0.1 msec while the amplitude is increased to 100 ma. (c) Repeat if the input is an impulse having a strength of 10^{-5} (coulomb).

Ans. 1000 volts; 1000 volts; 1000 volts

7-2 A 2-mh inductor is driven by a voltage source which is a triangular pulse rising linearly from zero to 100 volts in 5 μsec and then decreasing linearly to zero in another 5 μsec . (a) Find the magnitude of the inductor current 1 sec after the pulse terminates. (b) Repeat if the duration of the pulse is halved without any change in amplitude. (c) Repeat if the input is an impulse having a strength of 10^{-4} (volt-sec).

Ans. 0.05 amp; 0.125 amp; 0.25 amp

7-3 THE CURRENT IMPULSE

The unit impulse is the second type of singularity function we have met, and it possesses one characteristic which must be carefully noted before it can be meaningfully applied to circuit analysis. Whereas the unit-step function is a dimensionless function of time, the unit impulse possesses the dimensional symbol [T^{-1}]; it carries the unit "per second." This is evident from any of the integrals of the previous section which are a part of the definition of the unit impulse, and it also is a necessary consequence of the derivative relationship between the unit step and the unit impulse. Thus, if I_0 is a current, then $I_0u(t)$ is a current step and it is measured in amperes; $I_0\delta(t)$, however, is measured in amperes per second, a unit which rarely is physically significant.

Let us try to establish a clearer physical interpretation of a current impulse by making use of the short rectangular pulse as an approximation to an impulse. A rectangular current pulse having an amplitude of I_0 amp and a duration of Δ sec possesses an area of $I_0\Delta$ amp-sec, or $I_0\Delta$ coulombs. Such a current pulse therefore represents a total charge of $I_0\Delta$ coulombs flowing uniformly throughout the Δ -sec time interval. Let us fix our attention on the charge, rather than the current, by letting $Q_0 = I_0\Delta$. We therefore describe the amplitude of the pulse as Q_0/Δ amp. Now as Δ decreases, in the limit the rectangular pulse approaches an impulse. The area of the pulse and impulse must be equal, and the impulse must therefore have an area, or strength, of

Q_0 coulombs. Thus, the rectangular current pulse

$$i(t) = I_0 u(t) - I_0 u(t - \Delta)$$

and the current impulse

$$i(t) = Q_0 \delta(t)$$

are equivalent as $\Delta \rightarrow 0$ if

$$Q_0 = I_0 \Delta$$

In other words, the amplitude I_0 of the rectangular current pulse approaches infinity, its duration Δ approaches zero, while the product $Q_0 = I_0 \Delta$ remains constant. It is convenient to think of the current impulse in terms of this finite amount of charge which it represents, particularly when the current impulse is applied to a capacitor. A current impulse $i(t) = Q_0 \delta(t)$ represents a quantity of charge, and the amount of this charge is exactly equal to the strength of the current impulse. The application of this current impulse to a capacitor will result in the abrupt placement of this charge on the capacitor, in the sudden establishment of stored energy within the capacitor, and in the immediate presence of an equivalent voltage across the capacitor. Now let us relate this energy and voltage to the strength of the impulse and the size of the capacitor.

If a current impulse

$$i(t) = Q_0 \delta(t)$$

is caused to flow through a capacitor C , then the capacitor voltage may be determined by using the most general relationship between capacitor voltage and current,

$$e(t) = \frac{1}{C} \int_{t_0}^t i(t) dt + e(t_0)$$

We assume that the zero value of the impulse prior to $t = 0$ has not produced any capacitor voltage; thus, $e(t_0) = 0$ and

$$e(t) = \frac{1}{C} \int_{t_0}^t Q_0 \delta(t) dt$$

or
$$e(t) = \frac{Q_0}{C} \int_{t_0}^t \delta(t) dt$$

where $t_0 < 0$.

But, $\delta(t)$ is zero for $t < 0$ and, therefore,

$$e(t) = 0 \quad t < 0$$

and the voltage for $t > 0$ is obtained by using the defining relationship (7-6), rewritten here,

$$\int_{0^-}^{0^+} \delta(t) dt = 1$$

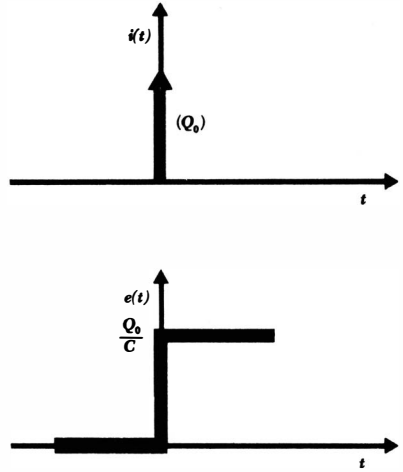

Fig. 7-5 The application of the current impulse $i(t) = Q_0\delta(t)$ to a capacitor C results in the voltage response $e(t) = (Q_0/C)u(t)$.

Thus,

$$e(t) = \frac{Q_0}{C} \quad t > 0$$

The capacitor voltage over both of these time intervals may be conveniently expressed by the single expression

$$e(t) = \frac{Q_0}{C} u(t) \tag{7-11}$$

The impulse source and the step response are illustrated in Fig. 7-5.

The capacitor voltage changes discontinuously from a zero value prior to $t = 0$ to a constant value after $t = 0$; energy has been stored in the capacitor within the interval from $t = 0^-$ to $t = 0^+$. This sudden change in capacitor voltage has not been possible in our previous work, but we did not then have the infinite power and infinite current which are now supplied by the current impulse.

We might check our result for capacitor voltage by using differential relationships rather than integral relationships. Thus, the application of the current impulse

$$i = Q_0\delta(t)$$

and the definition of capacitance

$$i = C \frac{de}{dt}$$

enable us to write

$$Q_0\delta(t) = C \frac{de}{dt} \quad \text{or} \quad \frac{Q_0}{C}\delta(t) = \frac{de}{dt}$$

209 The Unit Impulse and Its Applications

But
$$\delta(t) = \frac{d}{dt} u(t) \quad \text{or} \quad \frac{Q_0}{C} \delta(t) = \frac{Q_0}{C} \frac{d}{dt} u(t)$$

and a quick comparison yields

$$e(t) = \frac{Q_0}{C} u(t)$$

once again.

Finally, we should recognize that the interpretation of the current impulse as a packet of charge may point out the most satisfactory path to the answer. Capacitor charge and capacitor voltage are directly proportional,

$$q(t) = Ce(t)$$

and the charge Q_0 represented by the current impulse

$$i(t) = Q_0 \delta(t)$$

therefore establishes a voltage Q_0/C after the current impulse has struck.

Before we leave the current impulse and turn to the voltage impulse, let us determine the voltage which results when a current impulse is applied to an inductor L . Since

$$e(t) = L \frac{di}{dt}$$

and assuming the current impulse

$$i(t) = Q_0 \delta(t)$$

then

$$e(t) = LQ_0 \frac{d}{dt} [\delta(t)]$$

The inductor voltage has the form of the time derivative of the unit impulse; this is another singularity function, but it is not so important as either the unit step or the unit impulse, and we shall not need to discuss it in as much detail. We define the *unit doublet* $d(t)$,

$$d(t) = \frac{d}{dt} [\delta(t)] \tag{7-12}$$

and note that it may be approximated by a short, positive, rectangular pulse followed by an identical negative pulse. That is, if the unit impulse is considered as the limit of a triangular pulse of width 2Δ and amplitude $1/\Delta$, as $\Delta \rightarrow 0$, then the unit doublet is the limit of a positive rectangular pulse of width Δ and amplitude $1/\Delta^2$ followed immediately by a negative rectangular pulse of width Δ and amplitude $-1/\Delta^2$, as $\Delta \rightarrow 0$. The area under each pulse is infinite in the limit. The graphical symbol for a doublet is shown in Fig. 7-6; the strength of a doublet is defined to be the same as the strength of the impulse whose derivative it represents, and the strength is again shown in parentheses adjacent to the symbol.

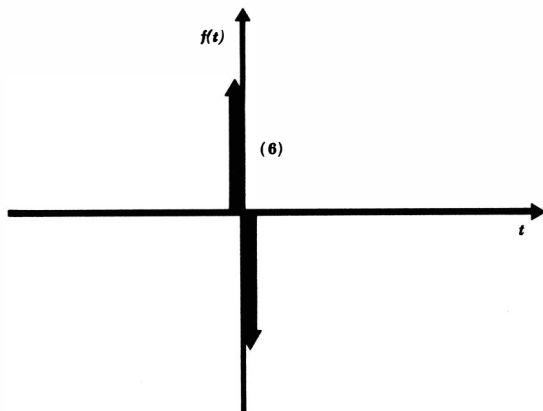

Fig. 7-6 The doublet $i(t) = 6d(t)$ is shown as a symbolic function of time. The strength of this doublet is 6.

Drill Problems

7-3 A current source $i_s(t)$ is in parallel with a 0.2-farad capacitor. Find the magnitude of the capacitor voltage at $t = 2$ sec if: (a) $i_s = 3u(t)$; (b) $i_s = 2\delta(t)$; (c) $i_s = \delta(t) + u(t - 1)$.

Ans. 10 volts; 10 volts; 30 volts

7-4 (a) In Drill Prob. 7-3 let $i_s = \epsilon^{-1/2}u(t)$ and find $e_C(2)$. (b) A useful but approximate method of solving a problem of this nature involves replacing the given current by a sequence of impulses of appropriate strengths at appropriate instants. Suppose that we consider i_s to be divided into intervals of 0.5-sec duration. The first interval roughly approximates a rectangular pulse of duration 0.5 sec and amplitude $\frac{1}{2}[i(0) + i(0.5)]$, the average of the initial and final values. This pulse may be approximated by an impulse occurring at the center of the interval and providing the same area, $i_1(t) = \frac{1}{2}[i(0) + i(0.5)] 0.5\delta(t - 0.25)$. Using the known value of i_s , we may evaluate the strength of i_1 and the three additional impulses which will be placed in the 2-sec interval with which we are concerned. Do this and calculate $e_C(2)$ by this approximate method. (c) Improve the approximation by using eight impulses. Again calculate $e_C(2)$.

Ans. 6.32 volts; 6.33 volts; 6.35 volts

7-4 THE VOLTAGE IMPULSE

Let us begin our interpretation of the voltage impulse by considering the dual of the application of a current impulse to a capacitor. Since the current impulse produces an abrupt change in the capacitor energy and capacitor voltage, we should expect the voltage impulse to produce an abrupt change in inductor energy and inductor current.

In the case of the capacitor, the current impulse represents a finite amount of charge, and this charge is suddenly placed on the capacitor plates, thus producing the stored energy. The dual of charge is *flux linkage*. Energy in an inductor is stored in its magnetic field, and it is convenient to think of a magnetic field physically as a collection of closed magnetic flux lines. Each line is interwoven with the physical coil; for example, a coil having but a single turn of wire and a single line of flux may be represented by a single turn of wire and a single rubber band. The rubber band links the wire and cannot be removed without breaking either the loop of wire or the rubber band. More rubber bands may be added to produce a more symmetrical model, because there is no preferred relationship between the number of flux lines and the number of rubber bands. The application of a voltage impulse to an inductor may thus be thought of as the sudden creation of a number of flux linkages, and it represents an accomplishment which is reminiscent of the way in which a magician can link "solid" Chinese rings together. Let us now relate the number of flux linkages obtained to the strength and area of the voltage impulse.

Since the charge on a capacitor is

$$q = Ce$$

then the dual of the charge is obtained by replacing C by L and e by i ,

$$\text{Flux linkages} = \lambda = Li$$

We shall assign the symbol λ (lambda) for flux linkage; the dimensions of flux linkage are volt-seconds (or *webers* or *weber-turns*), and the dimensional symbol is $[M^2LT^{-1}Q^{-1}]$. The unit of volt-seconds may be checked from the Li product, since a henry is a volt-second per ampere. The area under the voltage impulse is also measured in volt-seconds, and we therefore may think of a voltage impulse as a collection of flux linkages which are suddenly transferred to the inductor.

Let us now check these preliminary conclusions analytically. The voltage impulse is represented by

$$e(t) = \lambda_0\delta(t)$$

and it is seen to contain a flux linkage of λ_0 volt-sec; the strength of the voltage impulse is λ_0 volt-sec. Applying this voltage impulse to an inductor L , the resultant current is

$$i(t) = \frac{1}{L} \int_{t_0}^t e(t) dt + i(t_0) = \frac{1}{L} \int_{t_0}^t \lambda_0\delta(t) dt + i(t_0)$$

If t_0 is selected prior to zero time, then $i(t_0) = 0$, and

$$i(t) = \begin{cases} 0 & t < 0 \\ \frac{\lambda_0}{L} & t > 0 \end{cases}$$

or, more conveniently,

$$i(t) = \frac{\lambda_0}{L} u(t)$$

Thus, the voltage impulse is able to cause an abrupt change in the inductor current, the magnitude of the change being given by the strength of the impulse divided by the inductance. This agrees with the results of the discussion above in which we surmised that a current I_0 may be established by a flux linkage of LI_0 volt-sec. The assumption of the existence of the current impulse and the voltage impulse has therefore enabled us to produce an instantaneous change in capacitor voltage and inductor current, phenomena which have both been taboo previously.

When a voltage impulse

$$e(t) = \lambda_0 \delta(t)$$

is applied to a capacitor C , a current doublet is obtained,

$$i(t) = C \frac{de}{dt}$$

Thus

$$i(t) = C\lambda_0 d(t)$$

Drill Problems

7-5 The voltage source $e_s(t)$ is in series with a 5-henry inductor. Find the magnitude of the inductor current at $t = 4$ sec if: (a) $e_s(t) = 10\delta(t)$; (b) $e_s(t) = 3\delta(t) + 2u(t - 1) + \delta(t - 2)$; (c) $e_s(t) = 4 \left(\cos \frac{\pi}{6} t \right) \delta(t - 1)$.

Ans. 0.693 amp; 2 amp; 2 amp

7-6 A voltage source $e_s = 10[u(t) - u(t - 4)] \sin \frac{\pi}{4} t$ is in series with a 5-henry inductor. (a) Find the inductor current magnitude at $t = 4$. (b) Using the impulse approximation discussed in Drill Prob. 7-4, divide the 4-sec interval into four equal intervals, determine a suitable impulse to represent the voltage waveform at the mid-point of each interval, and evaluate $i_L(4)$. (c) Repeat for eight equal intervals.

Ans. 4.83 amp; 5.03 amp; 5.09 amp

7-5 THE USE OF IMPULSES TO REPRESENT INITIAL VALUES

Let us now determine how current impulses and voltage impulses may be used to represent initial values in a circuit, thus avoiding the need to use any switches. We may first assume that our circuit contains a capacitor C which possesses an initial voltage $e_C(0^-) = e_C(0^+) = E_0$; the analysis of the circuit is to be made for $t > 0$. We may use Thévenin's and Norton's theorems to obtain two useful equivalents. Applying Thévenin's theorem and treating the initial capacitor voltage as a source which must be rendered inactive as it was in applying superposition, we obtain an E_0 -volt d-c source in series with an initially *uncharged*

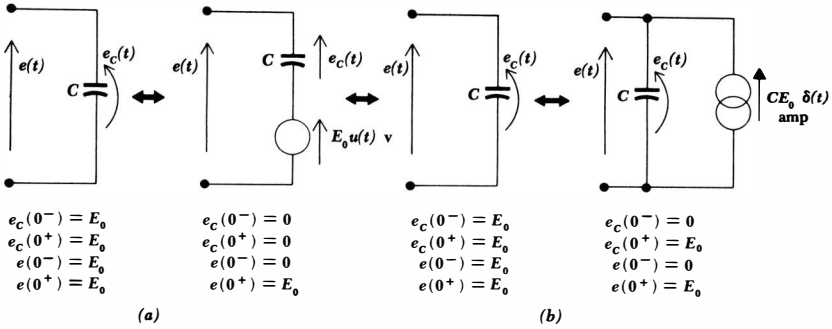

Fig. 7-7 (a) An initially charged capacitor and its Thévenin equivalent. (b) An initially charged capacitor and its Norton equivalent.

capacitor C . This E_0 -volt source is active only after $t = 0$, and we therefore represent it as a step-voltage source $E_0u(t)$. The equivalence of the two networks is indicated in Fig. 7-7a. The terminal voltages of the two networks are unequal at $t = 0^-$ but equal at $t = 0^+$.

If we apply Norton's theorem, the inactive network is again the capacitor C ; the short-circuit current is the natural response of an RC circuit with R equal to zero. The amplitude is infinite, the time constant is zero, and we evidently have a current impulse; the strength of the impulse is found by knowing that the total charge is CE_0 . Hence, the current impulse must have an area of CE_0 coulombs, and its strength is therefore CE_0 coulombs. The Norton equivalent network is thus the capacitor C in parallel with a current-impulse source $CE_0\delta(t)$. This equivalence is indicated by Fig. 7-7b; the inequality of the terminal voltages prior to $t = 0$ should be noted.

As an example of this use of the current impulse, consider the circuit shown in Fig. 7-8a. An inspection of the circuit shows that the capacitor voltage is 100 volts at the instant the switch is thrown. We may thus place a current-impulse source of strength $100C$ or 200 coulombs in parallel with the capacitor, knowing that it will place a charge of 200 coulombs or a voltage of 100 volts across the capacitor at $t = 0$. Moreover, the 40-volt battery does not appear in the circuit until $t = 0$, and it may therefore appear as a 40-volt step. The equivalent circuit is shown in Fig. 7-8b; it is equivalent to the given circuit from $t = 0^+$ on. The advantage of the equivalent circuit lies in the absence of any switches; the equivalent circuit does not change its form at $t = 0$, and it is often termed a *time-invariant* circuit. As a matter of fact, once switching operations have been abolished, we have a type of circuit which is referred to as a DTIL circuit, or discrete-parameter (meaning lumped elements, not distributed) time-invariant linear circuit. This is really the type of circuit discussed in this text; the presence of a switching operation at $t = 0$ merely means we have two different DTIL circuits to consider, one for $t < 0$ and one for $t > 0$, the relationships between the two circuits being the initial conditions.

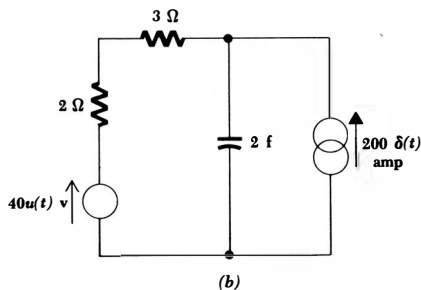
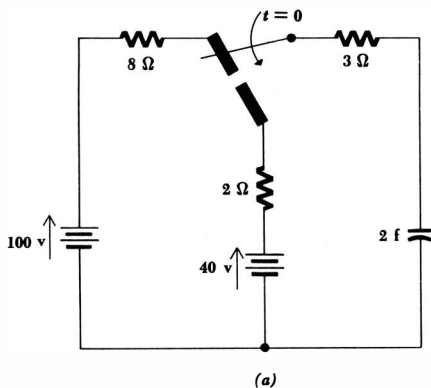

Fig. 7-8 (a) A given circuit. (b) A circuit which is equivalent to (a) for $t > 0$. No special statements need be made about the capacitor voltage.

It is worthwhile to mention a point now which is often a subject of worry to students. The initially charged capacitor has been replaced by an initially *uncharged* capacitor and a current-impulse source in parallel with the capacitor. This source provides the desired initial voltage at $t = 0^+$. How can we be sure, however, that the impulse does not “bypass” the capacitor and appear someplace else in the circuit? Or is it not possible that the remainder of the circuit can affect the magnitude of the voltage which will instantaneously appear across the capacitor? The assurance that the planned voltage does indeed appear across the capacitor arises from our faith in Thévenin’s and Norton’s theorems. We have merely replaced the two-terminal network containing only the initially charged capacitor with its Norton equivalent for $t > 0$; Norton and Thévenin equivalents, we know, are independent of the two-terminal network which represents the remainder of the network. Even if another capacitor is in parallel with the capacitor in which we are interested, the equivalent is correct, although Prob. 21 at the end of the chapter shows that we shall not have achieved the simplicity in this case which is our goal.

Similar simplifications may be made in replacing initially flux-linked inductors by equivalent networks in which initial inductor currents are zero. Let us assume an inductor L carrying an initial current $i_L(0^-) = i_L(0^+) = I_0$. The

Norton equivalent is evidently the inductor L in parallel with a d-c source I_0 after $t = 0$; the source is therefore represented by a step current $I_0u(t)$. The equivalence after $t = 0$ is outlined by the two networks shown in Fig. 7-9a. If we seek the Thévenin equivalent of this inductor carrying an initial current I_0 , we first obtain the inductor L as the inactive equivalent. The open-circuit voltage is equivalent to the natural-response voltage obtained in the RL circuit for an infinite resistance; the voltage amplitude is infinite, the time constant is zero, and the response is a voltage impulse. The inductor initially contains a flux linkage of LI_0 volt-sec, and the strength of the voltage impulse must also be LI_0 . Thus the Thévenin equivalent is the inductor L in series with a voltage impulse $LI_0\delta(t)$; the equivalence, valid only for $t > 0$, is shown in Fig. 7-9b.

Drill Problems

7-7 The initial voltages present on the three capacitors of Fig. 7-10a are to be replaced by singularity sources, as outlined by Fig. 7-10b. Find: (a) $e_1(t)$; (b) $e_2(t)$; (c) $e_3(t)$.

Ans. $12u(t)$ volts; $18u(t)$ volts; $24u(t)$ volts

7-8 The initial voltages present on the three capacitors of Fig. 7-10a are to be replaced now by singularity sources, as shown in Fig. 7-10c. Find: (a) $i_1(t)$; (b) $i_2(t)$; (c) $i_3(t)$.

Ans. $6\delta(t)$ amp; $3.6\delta(t)$ amp; $2.4\delta(t)$ amp

7-9 The energy stored initially in the inductors of Fig. 7-11a is to be supplied by singularity sources in the equivalent circuit of Fig. 7-11b. Determine: (a) $i_1(t)$; (b) $i_2(t)$; (c) $i_3(t)$.

Ans. $2u(t)$ amp; $4u(t)$ amp; $6u(t)$ amp

Fig. 7-9 (a) The Norton equivalent of an inductor carrying an initial current. (b) The Thévenin equivalent of an inductor carrying an initial current.

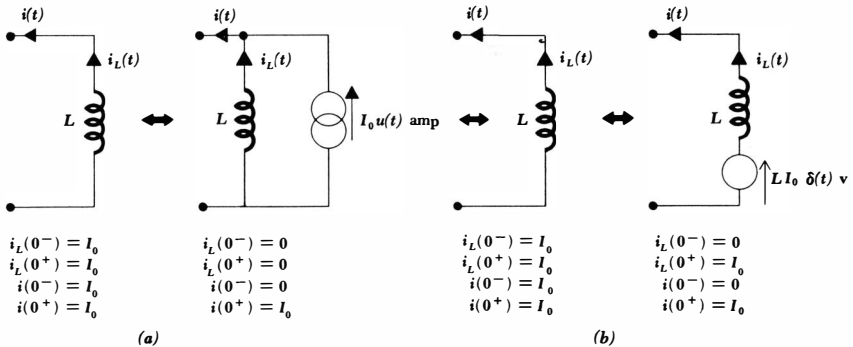

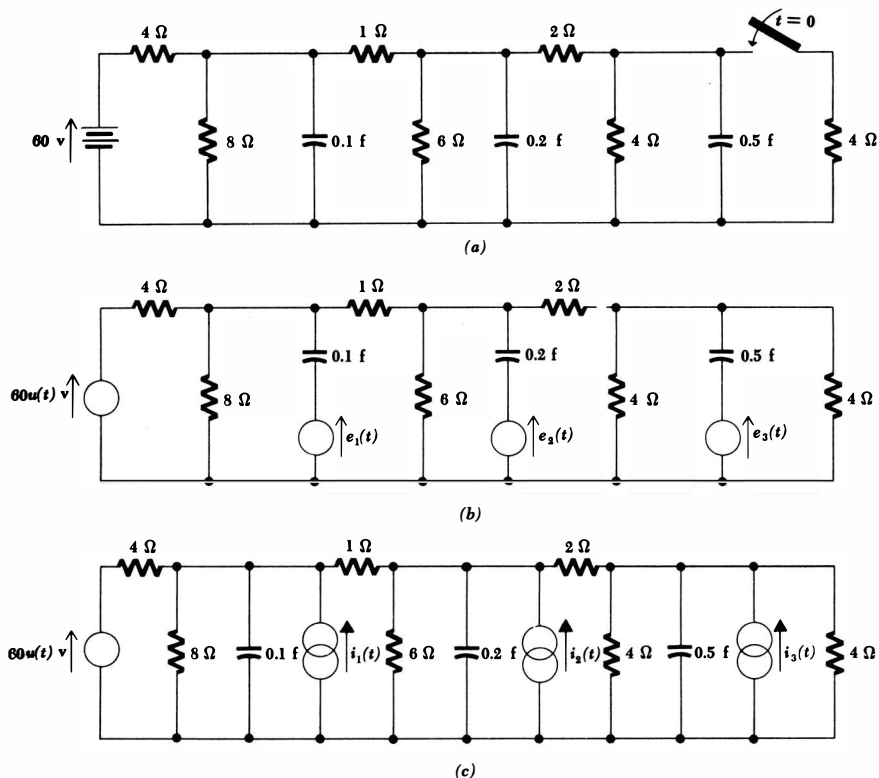

Fig. 7-10 (a) and (b) See Drill Prob. 7-7. (a) and (c) See Drill Prob. 7-8.

7-10 The energy stored initially in the inductors of Fig. 7-11a is to be supplied by singularity sources in the equivalent circuit of Fig. 7-11c. Determine: (a) $e_1(t)$; (b) $e_2(t)$; (c) $e_3(t)$.

Ans. $10\delta(t)$ volts; $12\delta(t)$ volts; $16\delta(t)$ volts

7-11 In the circuit shown in Fig. 7-12a, S_1 is closed and S_2 is open. (a) If S_1 is opened at $t = 0$ and S_2 is left open, determine $e_1(t)$ in Fig. 7-12b in order that the circuit may be equivalent to the given circuit from $t = 0^+$ until S_2 is closed. (b) S_2 is now closed at $t = 1.2$ sec. Determine $e_2(t)$ so that the circuit of Fig. 7-12c is equivalent to the original circuit for $t > 1.2$. (c) Determine $e_2(t)$ if every resistance and inductance in the original circuit is doubled.

Ans. $-61.6\delta(t - 1.2)$ volts; $-123.1\delta(t - 1.2)$ volts; $-180\delta(t)$ volts

7-6 RESPONSE IN CIRCUITS CONTAINING IMPULSE SOURCES

We know the response of the three individual passive elements to the unit impulse:

$$i(t) = Q_0\delta(t)$$

applied to a resistance R produces the voltage response

$$e(t) = Q_0R\delta(t)$$

and a voltage impulse

$$e(t) = \lambda_0\delta(t)$$

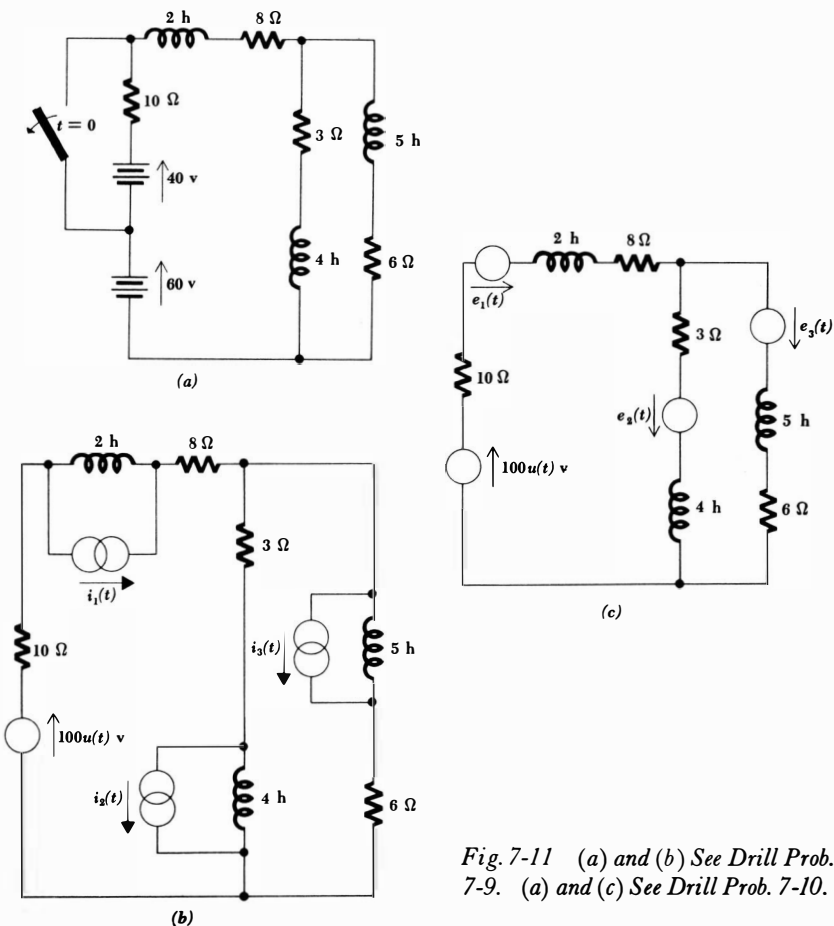

Fig. 7-11 (a) and (b) See Drill Prob. 7-9. (a) and (c) See Drill Prob. 7-10.

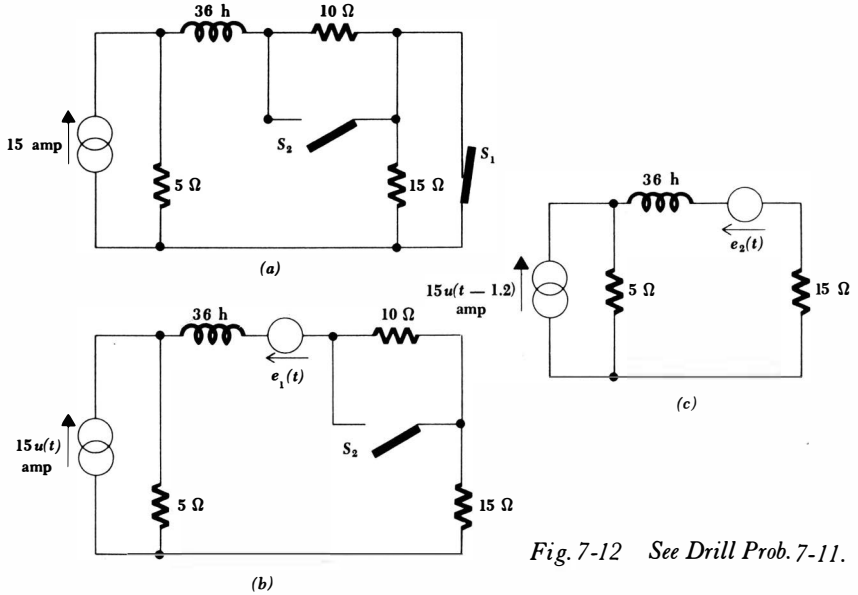

Fig. 7-12 See Drill Prob. 7-11.

applied to the resistor produces the current response

$$i(t) = \frac{\lambda_0}{R} \delta(t)$$

Applying the current impulse to a capacitor C yields the voltage response

$$e(t) = \frac{Q_0}{C} u(t)$$

whereas the voltage impulse across the capacitor must be accompanied by the current response

$$i(t) = C\lambda_0 d(t)$$

Finally, the voltage response of an inductor L to a current impulse is

$$e(t) = LQ_0 d(t)$$

and the current response of this inductor to a voltage impulse is

$$i(t) = \frac{\lambda_0}{L} u(t)$$

We now desire the response in circuits containing more than a single passive element or more than a single impulse source. The knowledge of the responses of the individual elements to impulse sources should enable us to analyze these

219 The Unit Impulse and Its Applications

circuits successfully. Let us begin by discussing several simple circuits to become acquainted with the most useful analysis methods.

Figure 7-13 shows a parallel RC circuit in parallel with an impulse source which we shall use as our first example. One method which we certainly may use involves considering the capacitor and impulse source as a two-terminal network in parallel with the resistor. The discussion of the Thévenin and Norton equivalents in the preceding section then enables us to replace the capacitor and impulse source by a capacitor initially charged to Q_0/C volts. The resistor voltage is therefore the familiar natural response

$$e_R(t) = \frac{Q_0}{C} \epsilon^{-t/RC} u(t)$$

It is enlightening now to consider the impulse source with respect to the manner in which this current “divides” between resistor and capacitor. The resistor current is obviously

$$i_R = \frac{e}{R} = \frac{Q_0}{RC} \epsilon^{-t/RC} u(t)$$

and the capacitor current may be obtained by differentiation,

$$i_C = C \frac{de}{dt} = Q_0 \frac{d}{dt} [\epsilon^{-t/RC} u(t)]$$

The derivative of this product yields both a step and an impulse,

$$i_C = Q_0 \left[-\frac{1}{RC} \epsilon^{-t/RC} u(t) + \epsilon^{-t/RC} \delta(t) \right]$$

or
$$i_C = Q_0 \delta(t) - \frac{Q_0}{RC} \epsilon^{-t/RC} u(t)$$

The sum of i_R and i_C is equal to the impulse current, and Kirchoff’s current law is satisfied. We now see that the impulse current itself appears as one of the terms making up the capacitor current; this may be explained physically by any of the following arguments. We have already discovered that when a current impulse of strength Q_0 flows through a capacitor C , the charge is transferred to the capacitor and produces a consequent voltage of Q_0/C volts across it. If we tentatively assume that this also occurs when a resistor R is present in parallel with the capacitor, then an initial resistor current of Q_0/RC amp

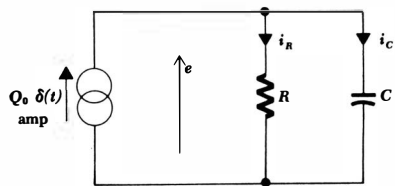

Fig. 7-13 A simple parallel circuit for which the voltage response is desired.

must flow. This current is of *finite* amplitude, however, and the removal of a finite current from the infinite amplitude of the current impulse still leaves an infinite-amplitude impulse. The current impulse is thus able to provide infinite current to the capacitor (the impulse itself) and a finite current to the resistor.

Alternatively, we may think of the response in terms of charge. The finite amount of charge contained in the current impulse produces a finite voltage across the capacitor and a finite current through the resistor. The finite resistor current represents the flow of a vanishingly small amount of charge through the resistor at the time at which the impulse strikes. Thus, in the limit, the Q_0 coulombs contained in the impulse all flow through the capacitor.

Let us now see if we can generalize from this conclusion that the impulse current chooses the capacitive path. If we first assume that the current through a capacitor changes discontinuously from one *finite* value to another *finite* value, then the impulse current is specifically outlawed and the capacitor voltage cannot change discontinuously; there is a current jump, but no voltage jump. We may think of the capacitor as behaving like a *short circuit*, across which a jump in current cannot produce any voltage change. In view of the discussion following our example above, it is apparent that the capacitor must also act as a short circuit when a current impulse is applied, because the current impulse chooses this path in preference to the resistive branch (or any inductive branch which might be present). The reason this occurs is discovered by allowing the change in the capacitor current to become an infinite discontinuity, thus corresponding to the rising portion of the current impulse. A finite, nonzero change in capacitor voltage results, but the ratio of the voltage change to the current change is once again zero. We may see the same phenomenon occurring in a short circuit; infinite current flowing through a zero resistance can produce an indeterminate, but finite, voltage. Thus, we may consider the capacitor as behaving like a short circuit at the instant at which any discontinuity is present; the ratio of the jump in capacitor current to the current discontinuity appearing in any resistive or inductive element in parallel with the capacitor is infinite. The same result occurs, of course, for a sudden decrease in current amplitude or on the falling portion of an impulse.

The interpretation of a capacitor as a short circuit at the instant of a discontinuity also provides the simplest method of analyzing a series circuit containing a discontinuity voltage. Thus, the series combination of a voltage source $E_0u(t)$, a resistor R , and a capacitor C yields a familiar circuit, and the replacement of the capacitor by a short circuit at $t = 0$ shows us that the entire voltage step must occur across the resistor. This leads to the solution obtained several chapters ago. If, now, we replace the step-voltage source by the impulse-voltage source $\lambda_0\delta(t)$, then we are forced to conclude that the impulse voltage appears across the resistor, but a *finite* voltage may be present across the capacitor. Moreover, the current which flows initially is $(\lambda_0/R)\delta(t)$, and thus the initial voltage which is found across the capacitor is λ_0/RC volts. The completion of this example as well as its analysis by applying Norton's theorem is left as Prob. 22 at the end of the chapter.

Let us now turn to the dual problems which contain inductors. Without

Fig. 7-14 An inductive circuit used as an example to illustrate the open-circuit behavior of an inductor at the instant of a discontinuity.

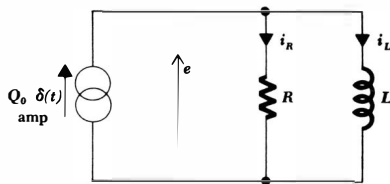

going into a detailed argument, which must be the dual of that for the capacitor, it should be apparent that an inductor should be treated as an open circuit at the instant at which any discontinuity occurs. Let us approach the example depicted in Fig. 7-14 in this light. Confronted with a choice between the resistive and inductive paths, the current impulse chooses the resistive one since the inductor behaves initially as an open circuit. Thus, a voltage

$$e = Q_0 R \delta(t)$$

appears initially across the resistor and inductor. This initial impulse across an inductor produces a sudden change in inductor current. Just after the impulse occurs, the inductor current is therefore

$$i_L(0^+) = \frac{Q_0 R}{L}$$

The problem has now been reduced to the simple natural response of the series RL circuit, because the source is inactive after the occurrence of the impulse. The inductor current is thus

$$i_L(t) = \frac{Q_0 R}{L} e^{-Rt/L} u(t)$$

while the resistor current is the impulse current plus the negative of the inductor current,

$$i_R(t) = Q_0 \delta(t) - \frac{Q_0 R}{L} e^{-Rt/L} u(t)$$

and the voltage across the parallel combination is $i_R R$ or $L(di_L/dt)$,

$$e(t) = Q_0 R \delta(t) - \frac{Q_0 R^2}{L} e^{-Rt/L} u(t)$$

This same example may also be studied by applying Thévenin's theorem to the network facing the inductor. The resultant series circuit is drawn in Fig. 7-15. The voltage impulse in series with the inductor represents an initial inductor current of $Q_0 R/L$ amp and leads to the same expression for this current as a function of time,

$$i_L(t) = \frac{Q_0 R}{L} e^{-Rt/L} u(t)$$

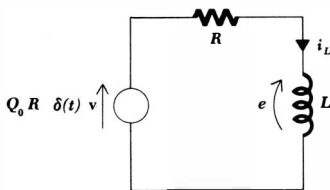

Fig. 7-15 The network facing the inductor in the circuit of Fig. 7-14 is replaced by its Thévenin equivalent.

Let us conclude our introduction of the impulse by considering a circuit which does not contain an impulse source, but which requires the use of the impulse in its response. Such a circuit may be obtained by neglecting the small series resistance of any physical capacitor. The currents i , i_1 , and i_2 are desired in the circuit shown in Fig. 7-16a. Perhaps the most rapid method of obtaining the solution is through consideration of the two capacitors as short circuits at $t = 0$. An infinite current must be supplied by the battery in the form of a current impulse; the impulse, in flowing through the two capacitors, must provide a voltage of 100 volts at $t = 0^+$. The strength of the impulse is therefore 7.5 coulombs. An initial voltage of 75 volts appears across the 0.1-farad capacitor, while 25 volts appears across the 0.3-farad capacitor initially. Thus, the initial value of i_2 is $\frac{25}{5}$ or 5 amp. From this knowledge and an inspection of the dead circuit, the expression for i_2 is apparent,

$$i_2(t) = 5e^{-0.5t}u(t)$$

We next obtain the voltage across the 5-ohm resistor or 0.3-farad capacitor and differentiate to find $i_1(t)$,

$$i_1(t) = 0.3 \frac{d}{dt}(5i_2)$$

or
$$i_1(t) = 7.5\delta(t) - 3.75e^{-0.5t}u(t)$$

from which $i(t)$ is easily found,

$$i(t) = i_1(t) + i_2(t)$$

$$i(t) = 7.5\delta(t) + 1.25e^{-0.5t}u(t)$$

Fig. 7-16 (a) An example of a circuit which requires the use of the impulse to describe the response. (b) An equivalent circuit obtained by applying Norton's theorem.

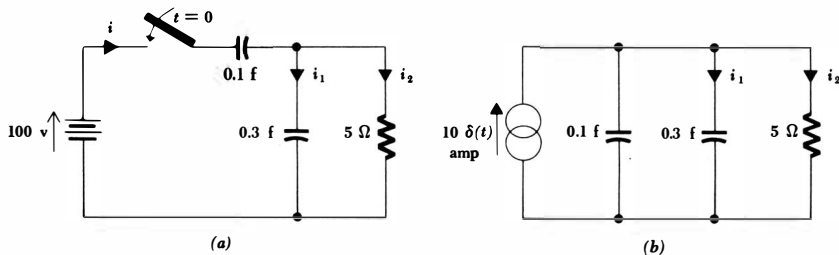

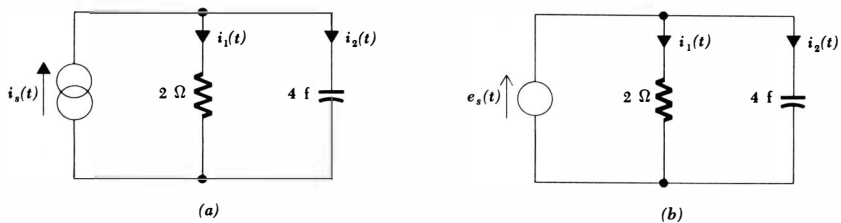

Fig. 7-17 (a) See Drill Prob. 7-12. (b) See Drill Prob. 7-13.

The presence of the predicted impulse in $i(t)$ and $i_1(t)$ should be noted.

More gradual methods may also be applied to the successful analysis of this circuit by applying Norton's and Thévenin's theorems until a simpler equivalent is obtained. Thus, if the battery, switch, and 0.1-farad capacitor are replaced by their Norton equivalent for $t > 0$, the circuit of Fig. 7-16b is obtained. A current impulse $10\delta(t)$ flows through the parallel combination of capacitors, producing an initial voltage of 25 volts. The initial value of i_2 is therefore 5 amp, and the solution for $i_2(t)$ is obtained as before.

Drill Problems

7-12 In the circuit shown in Fig. 7-17a: (a) if $i_s(t) = 2\delta(t)$, find $i_1(t)$; (b) if $i_s(t) = 2\delta(t)$, find $i_2(t)$; (c) if $i_s(t) = 2u(t)$, find $i_1(t)$.

Ans. $2\delta(t) - 0.25\epsilon^{-t/8}u(t)$ amp; $0.25\epsilon^{-t/8}u(t)$ amp; $2u(t) - 2\epsilon^{-t/8}u(t)$ amp

7-13 For the circuit shown in Fig. 7-17b: (a) if $e_s(t) = 2u(t)$, find $i_1(t)$; (b) if $e_s(t) = 2u(t)$, find $i_2(t)$; (c) if $e_s(t) = 2\delta(t)$, find $i_2(t)$.

Ans. $u(t)$ amp; $8\delta(t)$ amp; $8d(t)$ amp

7-14 In the circuit shown in Fig. 7-18a: (a) if $e_s(t) = 2u(t)$, find $e_1(t)$; (b) if $e_s(t) = 2\delta(t)$, find $e_1(t)$; (c) if $e_s(t) = 2\delta(t)$, find $e_2(t)$.

Ans. $2\delta(t) - 4\epsilon^{-2t}u(t)$ volts; $4\epsilon^{-2t}u(t)$ volts; $2u(t) - 2\epsilon^{-2t}u(t)$ volts

7-15 For the circuit shown in Fig. 7-18b: (a) if $i_s(t) = 2u(t)$, find $e_2(t)$; (b) if $i_s(t) = 2\delta(t)$, find $e_2(t)$; (c) if $i_s(t) = 2\delta(t)$, find $e_1(t)$.

Ans. $4\delta(t)$ volts; $8\delta(t)$ volts; $4d(t)$ volts

Problems

- Each of the following pulses is characterized by large amplitude and short duration, where "large" and "short" are relative terms referring to other amplitudes and time constants throughout the circuit. For each pulse, determine the strength of the impulse which approximately represents it:
 - a rectangular pulse, 100 volts in amplitude and 1 μ sec in duration;
 - a trapezoidal pulse, rising linearly from 0 to 0.1 amp in 0.1 μ sec, re-

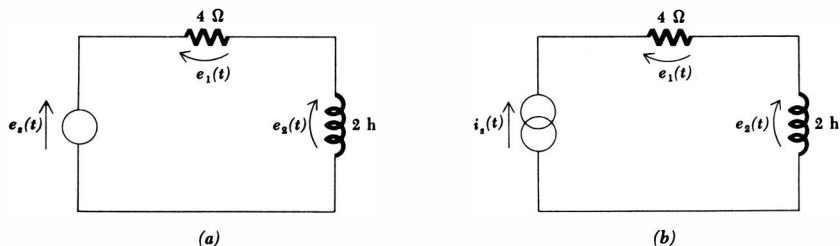

Fig. 7-18 (a) See Drill Prob. 7-14. (b) See Drill Prob. 7-15.

maining at 0.1 amp for 0.8 μsec , and decaying linearly to 0 in 0.1 μsec ; (c) a pulse which drops linearly from 0 to -10 ma in 0.1 sec and then rises abruptly to 0; (d) a voltage pulse which is represented analytically by $3000(\sin 2\pi 10^6 t)[u(t) - u(t - 0.5 \times 10^{-6})]$; (e) the current pulse which is present in a series RC circuit, $R = 1$ ohm, $C = 0.01$ farad, when a 100-volt battery is suddenly connected; (f) the voltage pulse which appears across the parallel combination of a 1-megohm resistor and a 10-mh inductor when a current of 0.2 amp is suddenly applied to the combination; (g) the output pulse from a blocking oscillator which is sketched in Fig. 7-19.

2 Find the numerical value of the strength of each of the impulses given below:

(a) $(\cos 2\pi t)\delta(t)$ (b) $\left[\sin\left(t + \frac{\pi}{6}\right)\right]\delta\left(t - \frac{\pi}{4}\right)$

(c) $12(1 - e^{-4t})\delta(t)$ (d) $\frac{d}{dt}[5u(t - 3)]$

(e) $\lim_{\alpha \rightarrow 0} \frac{1}{\alpha} \left(\cos \frac{\pi t}{2\alpha}\right) [u(t + \alpha) - u(t - \alpha)]$

3 Using the definition of inductance, show that the voltage across an inductor L , through which the current $tu(t - 1)$ is flowing, is composed of the sum of

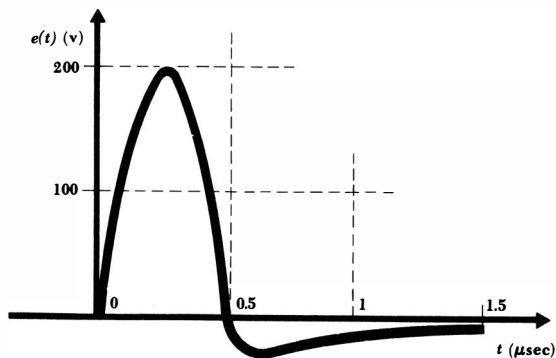

Fig. 7-19 See Prob. 1g.

a step and an impulse. Determine the strength of the impulse and the magnitude of the step.

- ◆4 The voltage $6(t + 2)u(t)$ volts is present across a 0.2-farad capacitor. Use the definition of capacitance to determine the capacitor current.
- 5 (a) The current impulse $5\delta(t)$ amp is applied to a 2-farad capacitor. Determine the voltage present across the terminals of the impulse source. (b) A 5-farad capacitor is placed in series with the above source and capacitor. Find the source voltage. Show that the result is the same if the capacitors are combined and the impulse is then applied, or if the voltages across the individual capacitors are obtained and added.
- 6 An impulse current $i_s(t) = Q_0\delta(t)$ is applied to two capacitors C_1 and C_2 in parallel. Show that

$$i_1(t) = Q_0 \frac{C_1}{C_1 + C_2} \delta(t) \quad \text{and} \quad i_2(t) = Q_0 \frac{C_2}{C_1 + C_2} \delta(t)$$

- 7 The current pulse of Prob. 1c is applied to a 1-farad capacitor. Sketch the capacitor voltage: (a) using the given current; (b) using the impulse approximation.
- ◆8 Two current sources $i_1(t)$ and $i_2(t)$ are in parallel with a 4-farad capacitor. If $i_1(t) = 5u(t)$, and if $i_2(t) = 0$ for $t < 4$ and $t > 4$, determine $i_2(t)$ in order that the capacitor voltage may be zero for $t > 4$.
- 9 (a) The voltage impulse $12\delta(t)$ volts is applied to a 3-henry inductor. Find the inductor current. (b) A 6-henry inductor is placed in parallel with the voltage source and 3-henry inductor. Find the source current. Show that the current obtained when the inductors are combined and the impulse is then applied is the same as that obtained when the currents through the individual inductors are found and then added.
- ◆10 Two inductors L_1 and L_2 are in series with an impulse voltage source $e_s(t) = \lambda_0\delta(t)$. Find the voltage across each inductor.
- 11 Apply the voltage pulse of Prob. 1a to a 4-mh inductor. (a) Sketch the inductor current. (b) The impulse approximation of this voltage pulse is now applied; sketch the current as a function of time.
- 12 A 10-henry inductor is in series with the two voltage sources $e_{s1} = 2\epsilon^{-t}u(t)$ and e_{s2} , where e_{s2} is zero for $t < 1$ and $t > 1$. Determine $e_{s2}(t)$ so that the inductor current is zero for $t > 1$.
- ◆13 (a) A current impulse $i_s(t) = 10^{-2}\delta(t)$ is applied to a series RL circuit in which $R = 100$ ohms, $L = 100$ μ h. Find the voltage across the current source. (b) A series capacitor $C = 100$ μ f is included in the above circuit. Find the voltage across the current source.
- ◆14 (a) A 10^5 -ohm resistor and a 1-mh inductor are in parallel. A voltage source $e_s = 100\delta(t)$ volts is applied to the parallel combination. Determine the source current. (b) A 0.01- μ f capacitor is placed in parallel with the above elements. Determine the source current.
- ◆15 A circuit without switches is desired which will be equivalent to the circuit shown in Fig. 7-20a for $t > 0$. (a) Obtain an equivalent of the form indicated by Fig. 7-20b. Carefully describe the circuit responses which are

226 **The Transient Circuit**

- equal in the two circuits. (b) Repeat for an equivalent of the form shown in Fig. 7-20c.
- 16 Repeat Prob. 15 for the circuits shown in Fig. 7-21a, b, and c.
- 17 Draw two or more equivalents of the circuit shown in Fig. 7-22a which contain singularity functions in place of switches. For each equivalent, state carefully the extent of the equivalence.
- 18 Repeat Prob. 17 for the circuit shown in Fig. 7-22b.

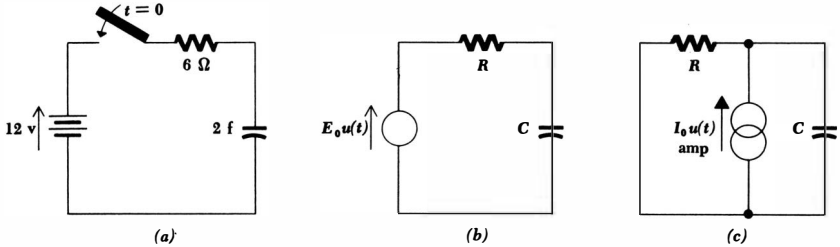

Fig. 7-20 See Prob. 15.

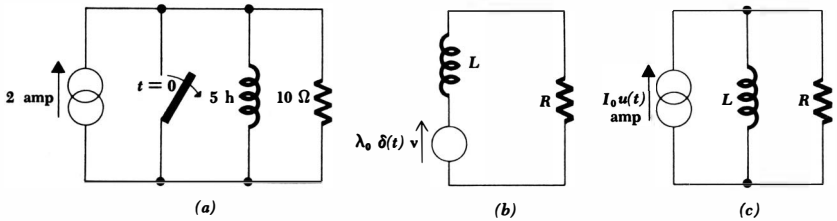
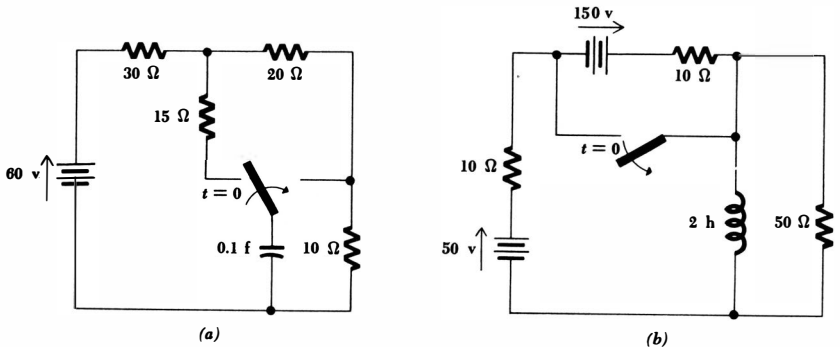

Fig. 7-21. See Prob. 16.

Fig. 7-22 (a) See Prob. 17. (b) See Prob. 18.



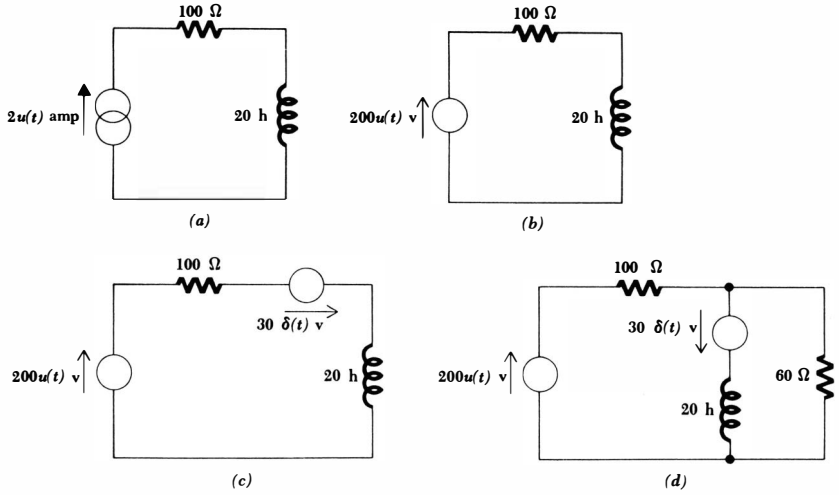
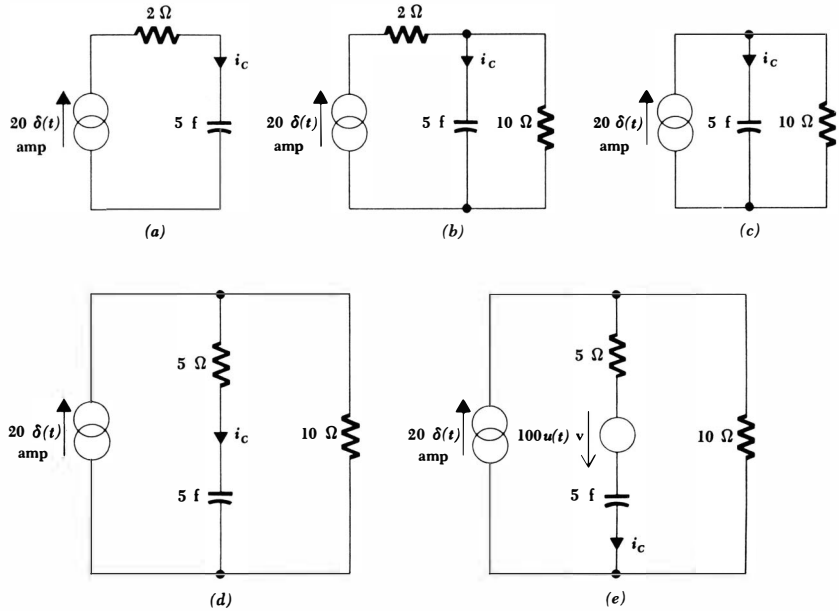

Fig. 7-23 See Prob. 19.

Fig. 7-24 See Prob. 20.



- ◆19 For each circuit shown in Fig 7-23, the 100-ohm resistor is the load. Find the load current in each circuit.
- 20 For each circuit shown in Fig. 7-24, find $i_C(t)$.
- 21 A 2-farad capacitor and a 1-farad capacitor in parallel are charged to 60 volts. At $t = 0$, a resistor is switched across the parallel combination. (a) Find the resistor current i_R for $t > 0$. (b) Treat the two capacitors as a single equivalent capacitor and provide a suitable current impulse to represent the initial energy. (c) Now replace only the charged 2-farad capacitor with an uncharged 2-farad capacitor and a suitable current impulse. It is still necessary to switch the charged 1-farad capacitor into the circuit at $t = 0$. Show that i_R is still the same as in parts a and b.
- ◆22 Complete the example left unfinished on page 220 by finding the current, the voltage across the resistor, and the voltage across the capacitor. Also replace the network facing the capacitor by its Norton equivalent and again find the capacitor current and voltage.

Chapter 8 *The RLC Circuit*

8-1 INTRODUCTION

It would be very pleasant to learn that the detailed study we have just completed for the RL and RC circuits will make the analysis of the RLC circuit a simple task; unfortunately the analysis still remains difficult. The presence of inductance and capacitance in the same circuit produces at least a *second-order system*, that is, one that is characterized by a linear differential equation including a second-order derivative. Although we have considered one second-order system in the final section of Chap. 5, most of our attention has been directed toward first-order systems which are described by first-order linear differential equations. From the single case we have considered, we should suspect that this increase in order will make it necessary to evaluate two arbitrary constants. Furthermore, it will be necessary to determine initial conditions for derivatives. And finally, we shall see that the presence of inductance and capacitance in the same circuit leads to a response which takes on different functional forms for circuits which have the same configuration but different element values. With this cheerful news, let us quickly review the methods and results we found useful for first-order systems, in order that we may extend this information as intelligently as possible to the second-order system.

We first considered the source-free first-order system. The response was termed the natural response, and it was determined completely by the types of passive elements in the network, by the manner in which they were interconnected, and by the initial conditions which were established by the stored energy. The natural response was invariably an exponentially decreasing function of time, and this response approached a constant value as time became infinite. The constant was usually zero, except in those circuits where paralleled inductors or series-connected capacitors allowed trapped currents or voltages to appear.

The addition of sources to the first-order system resulted in a two-part response, the familiar natural response and an additional term we called the forced response. This latter term was intimately related to the forcing function; its functional form was that of the forcing function itself, plus the integral and first derivative of the forcing function.¹ Since we treated only a constant forcing function, we have not needed to devote much attention to the proper form of the forced response; this problem will not arise until sinusoidal forcing functions are encountered in the following chapter. To the known forced response, we added the correct expression for the natural response, complete except for a multiplicative constant. This constant was evaluated to make the total response fit the prescribed initial conditions.

We now turn to circuits which are characterized by linear second-order differential equations. Our first task is the determination of the natural response. This is most conveniently done by considering initially the source-free circuit. We may then include d-c sources, switches, or step sources and impulse sources in the circuit, representing the total response once again as the sum of the natural response and the (usually constant) forced response. The second-order system that we are about to analyze is fundamentally the same as any lumped-constant mechanical second-order system. Our results, for example, will be of direct use to a mechanical engineer who is interested in the displacement of a spring-supported mass subjected to viscous damping, or one who is interested in the behavior of a simple pendulum or a torsional pendulum. Our results are still applicable, although less directly, to any distributed-parameter second-order system, such as a short-circuited transmission line, a diving board, a flute, or the ecology of the lemming. A lumped-constant mechanical system is described in several problems at the end of this chapter.

8-2 THE SOURCE-FREE PARALLEL CIRCUIT

Our first goal is the determination of the natural response of a simple circuit formed by connecting R , L , and C in parallel; this modest goal will be reached after completing this and the next three sections. This particular combination of ideal elements is a suitable model for portions of many communications networks. It represents, for example, an important part of some of the electronic (tube and transistor) amplifiers found in every radio receiver, and it enables the amplifiers to produce a large voltage amplification over a narrow band of signal frequencies and nearly zero amplification outside this band. Frequency selectivity of this kind enables us to listen to the transmission of one station while rejecting the transmission of any other station. Other applications include the use of parallel RLC circuits in multiplexing filters, harmonic suppression filters, and

¹ Higher-order derivatives will appear in higher-order systems, and, strictly speaking, we should say that all derivatives are present, although possibly with zero amplitude. Forcing functions which do not possess a finite number of different derivatives are exceptions which we shall not consider; the singularity functions are exceptions to the exceptions.

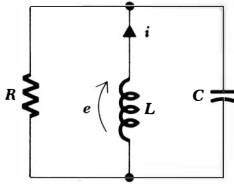

Fig. 8-1 The simple RLC parallel circuit.

so forth. But even a simple discussion of these principles requires an understanding of such terms as resonance, frequency response, and impedance which we have not yet discussed. Let it suffice to say, therefore, that an understanding of the natural behavior of the parallel *RLC* circuit is fundamentally important to future studies of communications networks and filter design.

When a physical inductor is connected in parallel with a capacitor, and the inductor has associated with it a nonzero ohmic resistance, the resulting network can be shown to have an equivalent circuit model like that shown in Fig. 8-1. Energy losses in the physical inductor are taken into account by the presence of the ideal resistor whose resistance R is dependent upon (but not equal to) the ohmic resistance of the inductor.

In the following analysis we shall assume that energy may be stored initially in both the inductor and the capacitor, and thus nonzero values of both inductor current and capacitor voltage are initially present. With reference to the circuit of Fig. 8-1, we may then write the single nodal equation

$$\frac{e}{R} + \frac{1}{L} \int_{t_0}^t e \, dt - i(t_0) + C \frac{de}{dt} = 0 \quad (8-1)$$

Note that the minus sign is a consequence of the assumed direction for i . We must solve Eq. (8-1) subject to the initial conditions

$$i(0^+) = I_0 \quad (8-2)$$

$$e(0^+) = E_0 \quad (8-3)$$

When both sides of Eq. (8-1) are differentiated once with respect to time, the result is the linear second-order homogeneous differential equation

$$C \frac{d^2e}{dt^2} + \frac{1}{R} \frac{de}{dt} + \frac{1}{L} e = 0 \quad (8-4)$$

whose solution $e(t)$ is the desired natural response.

There are a number of interesting ways to solve Eq. (8-4). These methods we shall leave to a course in differential equations, selecting only the quickest and simplest method to use now. We shall assume a solution, relying upon our intuition and modest experience to select one of the several possible forms which are suitable. Our experience with the first-order equation should suggest that we at least try the exponential form once more. Moreover, the form of Eq. (8-4) indicates that this may work, because we must add three terms, the second derivative, first derivative, and the function itself, each multiplied by a constant factor, and achieve a sum of zero. A function whose derivatives have the same

232 The Transient Circuit

form as the function itself is obviously a sensible choice. With every hope for success, then, we assume

$$e = A\epsilon^{st} \tag{8-5}$$

where we shall be as general as possible by allowing A and s to be complex numbers if necessary.² Substituting Eq. (8-5) into Eq. (8-4), we obtain

$$CA s^2 \epsilon^{st} + \frac{1}{R} A s \epsilon^{st} + \frac{1}{L} A \epsilon^{st} = 0$$

or
$$A \epsilon^{st} \left(C s^2 + \frac{1}{R} s + \frac{1}{L} \right) = 0$$

In order for this equation to be satisfied for all time, one of the three factors must be zero. If either of the first two factors is put equal to zero, then $e(t) = 0$. This is a trivial solution of the differential equation which cannot satisfy our given initial conditions. We therefore equate the remaining factor to zero,

$$C s^2 + \frac{s}{R} + \frac{1}{L} = 0 \tag{8-6}$$

This equation is usually called the *auxiliary equation* or the *characteristic equation* by mathematicians. If it can be satisfied, then our assumed solution is correct. Since Eq. (8-6) is a quadratic equation, there are two solutions, identified as s_1 and s_2 ,

$$s_1 = -\frac{1}{2RC} + \sqrt{\left(\frac{1}{2RC}\right)^2 - \frac{1}{LC}} \tag{8-7}$$

and
$$s_2 = -\frac{1}{2RC} - \sqrt{\left(\frac{1}{2RC}\right)^2 - \frac{1}{LC}} \tag{8-8}$$

If either of these two values is used for s in the assumed solution, then that solution satisfies the given differential equation; it thus becomes a valid solution of the differential equation.

Let us assume that we replace s by s_1 in Eq. (8-5), obtaining

$$e_1 = A_1 \epsilon^{s_1 t}$$

and, similarly,

$$e_2 = A_2 \epsilon^{s_2 t}$$

The former satisfies the differential equation

$$C \frac{d^2 e_1}{dt^2} + \frac{1}{R} \frac{de_1}{dt} + \frac{1}{L} e_1 = 0$$

² There is no cause for panic. Complex numbers will appear in this chapter only in an introductory way in the derivations. Their use as a tool will be necessary in Chap. 10.

233 The RLC Circuit

and the latter satisfies

$$C \frac{d^2 e_2}{dt^2} + \frac{1}{R} \frac{de_2}{dt} + \frac{1}{L} e_2 = 0$$

Adding these two differential equations and combining similar terms,

$$C \frac{d^2(e_1 + e_2)}{dt^2} + \frac{1}{R} \frac{d(e_1 + e_2)}{dt} + \frac{1}{L} (e_1 + e_2) = 0$$

linearity triumphs, and it is seen that the sum of the two solutions is also a solution. We thus have the form of the natural response

$$e = A_1 e^{s_1 t} + A_2 e^{s_2 t} \quad (8-9)$$

where s_1 and s_2 are given by Eqs. (8-7) and (8-8), and A_1 and A_2 are two arbitrary constants which are to be selected to satisfy the two specified initial conditions.

The form of the natural response as given above can hardly be expected to bring forth any expressions of interested amazement, for, in its present form, it offers little insight into the nature of the curve we might obtain if $e(t)$ were plotted as a function of time. The relative amplitudes of A_1 and A_2 , for example, will certainly be important in determining the nature of the response curve. Furthermore, either the constants s_1 and s_2 can be real numbers or they can be conjugate complex numbers, depending upon the values of R , L , and C in the given network. These two cases will produce fundamentally different response forms. Therefore it will be helpful to make some simplifying substitutions in Eq. (8-9) for the sake of conceptual clarity.

Since the exponents $s_1 t$ and $s_2 t$ must be dimensionless, s_1 and s_2 must have the unit of some dimensionless quantity "per second." When we defined resistance, inductance, and capacitance we determined the dimensional symbols that were associated with these quantities, and this information might also be used to show that the dimensions of s_1 , s_2 , $1/2RC$, and $\sqrt{1/LC}$ must all be $[T^{-1}]$. Units of this type are called *frequencies*. Although we shall expand this concept in much more detail in Chap. 14, we shall introduce several of the terms now. Let us represent $\sqrt{1/LC}$ by ω_0 (omega),

$$\omega_0 = \frac{1}{\sqrt{LC}} \quad (8-10)$$

and reserve the term *resonant frequency*³ for it. On the other hand, we shall call $1/2RC$ the *neper frequency* or the *exponential damping coefficient* and represent it by the symbol α (alpha),

$$\alpha = \frac{1}{2RC} \quad (8-11)$$

This latter descriptive expression is used because α is a measure of how rapidly the natural response decays or damps out to its steady final value (usually zero).

³ More accurately, the resonant *radian* frequency.

234 The Transient Circuit

Finally, s , s_1 , and s_2 , which are quantities that will form the basis for some of our later work, will be called *complex frequencies*.

Let us collect these results. The natural response of the parallel RLC circuit is

$$e(t) = A_1 e^{s_1 t} + A_2 e^{s_2 t} \quad (8-9)$$

where

$$s_1 = -\alpha + \sqrt{\alpha^2 - \omega_0^2} \quad (8-12)$$

$$s_2 = -\alpha - \sqrt{\alpha^2 - \omega_0^2} \quad (8-13)$$

$$\alpha = \frac{1}{2RC} \quad (8-11)$$

$$\omega_0 = \frac{1}{\sqrt{LC}} \quad (8-10)$$

and A_1 and A_2 must be found by applying the given initial conditions.

It is now apparent that the nature of the response depends upon the relative magnitudes of α and ω_0 . The radical appearing in the expressions for s_1 and s_2 will be real when α is greater than ω_0 , imaginary when α is less than ω_0 , and zero when α and ω_0 are equal. Each of these cases will be considered separately in the following three sections.

Drill Problems

8-1 A very lossy 200- μf capacitor has 100 volts applied to it in the laboratory. After the voltage source is removed, measurements with an oscilloscope show that the voltage decays to 50 volts in 6.93 msec. From these data, an equivalent parallel resistance can be calculated. The lossy capacitor is placed in parallel with an ideal 2.5-henry inductor. For the equivalent parallel RLC circuit formed, find: (a) α ; (b) ω_0 ; (c) s_1 .

Ans. -27.6 sec^{-1} ; 50 sec^{-1} ; 44.7 sec^{-1}

8-2 It is known that $s_1 = -5$ and $s_2 = -15$ for a certain parallel RLC circuit. Find C if: (a) $R = 20$ ohms; (b) $L = 2$ henrys; (c) $1/\omega_0 C = 20$ (ohms).

Ans. 0.00667 farad; 0.00250 farad; 0.00577 farad

8-3 THE OVERDAMPED PARALLEL RLC CIRCUIT

It is apparent that α will be greater than ω_0 and α^2 will be greater than ω_0^2 if $LC > 4R^2C^2$. In this case the radical we are concerned with will be real, and both s_1 and s_2 will be real. Moreover, the following inequalities, which are evident by inspection of Eqs. (8-12) and (8-13),

$$\begin{aligned} \sqrt{\alpha^2 - \omega_0^2} &< \alpha \\ (-\alpha - \sqrt{\alpha^2 - \omega_0^2}) &< (-\alpha + \sqrt{\alpha^2 - \omega_0^2}) < 0 \end{aligned}$$

show that both s_1 and s_2 are negative real numbers. Thus, the response $e(t)$ can be expressed as the (algebraic) sum of two decreasing exponential terms, both of which approach zero as time increases without limit. In fact, since the absolute value of s_2 is larger than that of s_1 , the term containing s_2 has the more rapid rate of decrease and, for large values of time, we may write the limiting expression

$$e(t) \rightarrow A_1 e^{s_1 t} \rightarrow 0 \quad \text{as } t \rightarrow \infty$$

In order to discuss the method by which the arbitrary constants A_1 and A_2 are selected to conform with the initial conditions, and in order to provide a typical example of a response curve, let us turn to a numerical example. We shall select a parallel RLC circuit for which $R = 6$ ohms, $L = 7$ henrys, and $C = \frac{1}{42}$ farad; the initial energy storage is specified by choosing an initial voltage across the circuit $e(0) = 0$ and an initial inductor current $i(0) = 10$ amp, as shown in Fig. 8-2.

We may easily determine the values of the several parameters

$$\begin{aligned} \alpha &= 3.5 & \omega_0 &= \sqrt{6} \\ s_1 &= -1 & s_2 &= -6 \end{aligned}$$

and immediately write the general form of the natural response

$$e(t) = A_1 e^{-t} + A_2 e^{-6t} \tag{8-14}$$

Only the evaluation of the two constants A_1 and A_2 remains. If we knew the response $e(t)$ at two different values of time, these two pairs of values could be substituted in Eq. (8-14) and A_1 and A_2 easily found. However, we know only the initial value of $e(t)$,

$$e(0) = 0$$

and, therefore,

$$0 = A_1 + A_2 \tag{8-15}$$

A second equation relating A_1 and A_2 must be obtained by taking the derivative of $e(t)$ with respect to time in Eq. (8-14), determining the initial value of this derivative through the use of the remaining initial condition $i(0) = 10$, and equating the results. Taking the derivative of both sides of Eq. (8-14),

$$\frac{de}{dt} = -A_1 e^{-t} - 6A_2 e^{-6t}$$

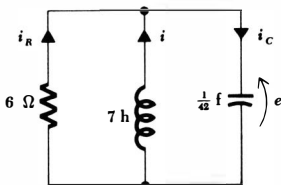

Fig. 8-2 A parallel RLC circuit used as a numerical example. The circuit is overdamped.

evaluating the derivative at $t = 0$,

$$\left. \frac{de}{dt} \right|_{t=0} = -A_1 - 6A_2$$

we next pause to consider how the initial value of the derivative can be found numerically. This next step is always suggested by the derivative itself; de/dt suggests capacitor current, for

$$i_c = C \frac{de}{dt}$$

Thus,

$$\begin{aligned} \left. \frac{de}{dt} \right|_{t=0} &= \frac{i_c(0)}{C} = \frac{i(0) + i_R(0)}{C} = \frac{i(0)}{C} \\ &= 420 \text{ volts/sec} \end{aligned}$$

since zero voltage across the resistor requires zero current through it. We thus have our second equation

$$420 = -A_1 - 6A_2 \quad (8-16)$$

and simultaneous solution of Eqs. (8-15) and (8-16) provides the two amplitudes $A_1 = 84$ and $A_2 = -84$. Thus, the final numerical solution for the natural response is

$$e(t) = 84(\epsilon^{-t} - \epsilon^{-6t}) \quad (8-17)$$

The evaluation of A_1 and A_2 for other conditions of initial energy storage, including initial energy storage in the capacitor, is considered in the first drill problem following this section.

Let us see what information we can glean from Eq. (8-17) without calculating unduly. We note that $e(t)$ is zero at $t = 0$, a comforting check on our original assumption. We may also interpret the first exponential term as having a time constant of 1 sec and the other exponential, a time constant of $\frac{1}{6}$ sec. Each starts with unity amplitude, but the second decays more rapidly; $e(t)$ is thus always positive. As time becomes infinite, each term approaches zero, and the response itself dies out as it should. We thus have a response curve which is zero at $t = 0$, zero at $t = \infty$, and is always positive; since it is not everywhere zero, it must possess at least one maximum, and this is not a difficult point to determine exactly. We differentiate the response

$$\frac{de}{dt} = 84(-\epsilon^{-t} + 6\epsilon^{-6t})$$

set the derivative equal to zero to determine the time t_m at which the voltage becomes maximum,

$$0 = -\epsilon^{-t_m} + 6\epsilon^{-6t_m}$$

manipulate once,

$$\epsilon^{5t_m} = 6$$

and obtain

$$t_m = 0.358$$

and $e(t_m) = 48.9$ volts

A reasonable sketch of the response may be made by plotting the two exponential terms $84e^{-t}$ and $84e^{-6t}$ and then taking their difference. The usefulness of this technique is indicated by the curves of Fig. 8-3; the two exponentials are shown lightly, and their difference, the total response $e(t)$, is drawn with a heavier line. The curves also verify our previous prediction that the functional behavior of $e(t)$ for very large t is $84e^{-t}$, the exponential term containing the smaller magnitude of s_1 and s_2 .

Another question that frequently arises in the consideration of network response is concerned with the length of time it takes for the transient part of the response to disappear (or damp out). In practice, it is often desirable to have this transient response approach zero as rapidly as possible, that is, to minimize the settling time t_s . Theoretically, of course, t_s is infinite, because $e(t)$ never settles to zero in a finite time. However, a negligible response is present after

Fig. 8-3 The response $e(t) = 84(\epsilon^{-t} - \epsilon^{-6t})$ of the network which is shown in Fig. 8-2.

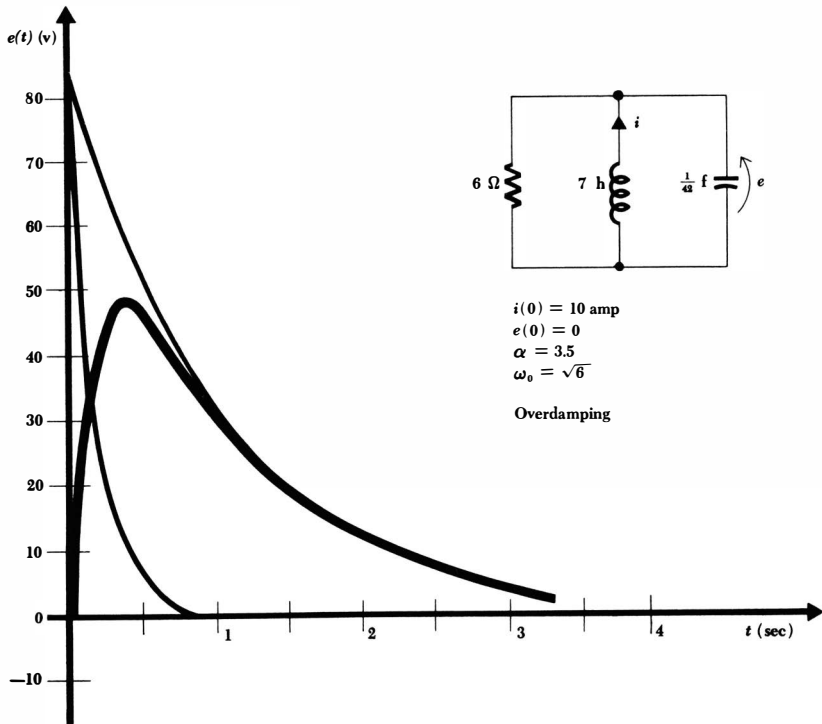

$e(t)$ has settled to values that are less than 1 per cent of its maximum value e_m . The time which is required for this to occur is defined as the settling time. Since e_m is 48.9 volts for our example, the settling time is the time required for the response to drop to 0.489 volt. Substituting this value for $e(t)$ into Eq. (8-17) and neglecting the second exponential term, known to be negligible here, the settling time is found to be 5.15 sec.

In comparison with the responses which we shall obtain in the following two sections, this is a comparatively large settling time; the damping takes overly long, and the response is called overdamped. We shall refer to the case for which α is greater than ω_0 as the *overdamped* case. Now let us see what happens as α is decreased.

Drill Problems

8-3 If the initial voltage across a parallel *RLC* circuit is not zero, then the resultant value of the initial resistor current must be considered in evaluating the initial value of de/dt . For the numerical example considered in the above section, determine A_1 and A_2 for these initial conditions: (a) $e(0) = 0$, $i(0) = 5$ amp; (b) $e(0) = 10$ volts, $i(0) = 4\%$ amp; (c) $e(0) = 21$ volts, $i(0) = 3$ amp.

Ans. 42 volts, -42 volts; 21 volts, 0 volt; 110 volts, -100 volts

8-4 Determine the value of time t_m at which the magnitude of $e(t)$ is a maximum for each of the networks described below. Since the complete specifications and the response are both given, additional practice in finding the overdamped response is thereby made available.

- (a) $R = 6$ ohms, $L = 7$ henrys, $C = \frac{1}{2}$ farad, $e(0) = 50$ volts, $i(0) = 27\frac{1}{2}$ amp, $e(t) = 100e^{-t} - 50e^{-6t}$
 (b) $R = 6$ ohms, $L = 7$ henrys, $C = \frac{1}{2}$ farad, $e(0) = 99$ volts, $i(0) = 59\frac{1}{2}$ amp, $e(t) = 100e^{-t} - e^{-6t}$
 (c) $R = 6$ ohms, $L = 3.5$ henrys, $C = \frac{1}{2}$ farad, $e(0) = -10$ volts, $i(0) = -10\frac{1}{2}$ amp, $e(t) = 10e^{-3t} - 20e^{-4t}$ (tricky)

Ans. 0 sec; 0 sec; 0.220 sec

8-4 CRITICAL DAMPING

The overdamped case is characterized by

$$\alpha > \omega_0$$

or $LC > 4R^2C^2$

and leads to negative real values for s_1 and s_2 and to a response expressed as the algebraic sum of two negative exponentials. Typical forms of the response $e(t)$ are obtained through the numerical example in the last section and in the drill problems following it.

Now let us adjust the element values until α and ω_0 are equal. This is a very special case which is termed *critical damping*. Thus, critical damping is achieved when

$$\alpha = \omega_0$$

$$\text{or} \quad LC = 4R^2C^2 \quad \text{critical damping}$$

$$\text{or} \quad L = 4R^2C$$

It is obvious that we may produce critical damping by changing the value of any one of the three elements in the numerical example discussed above. We shall select R , increasing its value until critical damping is obtained, and thus leave ω_0 unchanged. The necessary value of R is $7\sqrt{6}/2$ ohms; L is still 7 henrys, and C remains $1/42$ farad. We thus find

$$\alpha = \omega_0 = \sqrt{6}$$

$$s_1 = s_2 = -\sqrt{6}$$

and we blithely construct the response as the sum of the two exponentials,

$$e(t) \stackrel{?}{=} A_1 e^{-\sqrt{6}t} + A_2 e^{-\sqrt{6}t}$$

which may be written as

$$e(t) \stackrel{?}{=} A_3 e^{-\sqrt{6}t}$$

At this point, some of us should feel we have lost our way. We have a response which contains only one arbitrary constant, but there are two initial conditions $e(0) = 0$ and $i(0) = 10$ which must be satisfied by this single constant. This is in general impossible. In our case, for example, the first initial condition requires A_3 to be zero, and it is then impossible to satisfy the second initial condition.

Our mathematics and our electricity have been unimpeachable; therefore, if a mistake has not led to our difficulties, we must have begun with an incorrect assumption, and only one assumption has been made. We originally hypothesized that the differential equation could be solved by assuming an exponential solution, and this turns out to be incorrect for this single special case of critical damping. We must therefore return to the differential equation and attempt to solve it by some other means than an assumed solution. Although this detailed solution is carried out below, we should realize that it is the final functional form of the response which is important to us, and not the specific method by which it is obtained. After all, if we were clever enough, we could assume a response of the correct form and then check it by direct substitution in the differential equation.

The original differential equation, Eq. (8-4),

$$C \frac{d^2 e}{dt^2} + \frac{1}{R} \frac{de}{dt} + \frac{1}{L} e = 0$$

may be written in terms of α and ω_0 ,

$$\frac{d^2 e}{dt^2} + 2\alpha \frac{de}{dt} + \omega_0^2 e = 0$$

240 The Transient Circuit

which becomes, for critical damping,

$$\frac{d^2e}{dt^2} + 2\alpha \frac{de}{dt} + \alpha^2 e = 0$$

or
$$\frac{d^2e}{dt^2} + \alpha \frac{de}{dt} + \alpha \frac{de}{dt} + \alpha^2 e = 0$$

and finally,

$$\frac{d}{dt} \left(\frac{de}{dt} + \alpha e \right) + \alpha \left(\frac{de}{dt} + \alpha e \right) = 0$$

If we now let

$$y = \frac{de}{dt} + \alpha e$$

then

$$\frac{dy}{dt} + \alpha y = 0$$

which is a form we have encountered before. Its solution is

$$y = A_1 \epsilon^{-\alpha t}$$

and, therefore,

$$\frac{de}{dt} + \alpha e = A_1 \epsilon^{-\alpha t}$$

This equation has the form of Eq. (6-2), and therefore we should be able to solve it by the use of an integrating factor. The integrating factor is $\epsilon^{+\alpha t}$, and we multiply both sides of the equation by it,

$$\epsilon^{\alpha t} \frac{de}{dt} + \alpha \epsilon^{\alpha t} e = A_1$$

recognize the derivative of the product and simplify,

$$\frac{d}{dt} (e \epsilon^{\alpha t}) = A_1$$

Finally, we integrate each side directly,

$$e \epsilon^{\alpha t} = A_1 t + A_2$$

and obtain the desired response form

$$e = \epsilon^{-\alpha t} (A_1 t + A_2) \tag{8-18}$$

It should be noted that the solution may be expressed as the sum of two terms, where one term is the familiar negative exponential but the second is t times a negative exponential. We should also note that the solution contains the *two* expected arbitrary constants.

241 The RLC Circuit

Let us now complete our numerical example. After we substitute the known value of α into Eq. (8-18),

$$e = A_1 t \epsilon^{-\sqrt{6}t} + A_2 \epsilon^{-\sqrt{6}t}$$

we establish the values of A_1 and A_2 by first imposing the initial condition on $e(t)$ itself, $e(0) = 0$. Thus, $A_2 = 0$. This simple result occurs because the initial value of the response was selected as zero; the more general case, which leads to an equation determining A_2 , may be expected to arise in the drill problems. The second initial condition must be applied to the derivative de/dt just as in the overdamped case. We therefore differentiate, remembering that $A_2 = 0$,

$$\frac{de}{dt} = A_1 t(-\sqrt{6})\epsilon^{-\sqrt{6}t} + A_1 \epsilon^{-\sqrt{6}t}$$

evaluate at $t = 0$,

$$\left. \frac{de}{dt} \right|_{t=0} = A_1$$

express the derivative in terms of the initial capacitor current,

$$\left. \frac{de}{dt} \right|_{t=0} = \frac{i_C(0)}{C} = \frac{i_R(0)}{C} + \frac{i(0)}{C}$$

and thus

$$A_1 = 420$$

The response is, therefore,

$$e(t) = 420t\epsilon^{-2.45t} \tag{8-19}$$

Before plotting this response in detail, let us again try to anticipate its form by qualitative reasoning. The specified initial value is zero, and Eq. (8-19) concurs. It is not immediately apparent that the response also approaches zero as t becomes infinitely large because $t\epsilon^{-2.45t}$ is an indeterminate form. However, this minor obstacle is easily overcome by use of L'Hôpital's rule. Thus,

$$\lim_{t \rightarrow \infty} e(t) = 420 \lim_{t \rightarrow \infty} \frac{t}{\epsilon^{2.45t}} = 420 \lim_{t \rightarrow \infty} \frac{1}{2.45\epsilon^{2.45t}} = 0$$

and once again we have a response which begins and ends at zero and has positive values at all other times. A maximum value e_m again occurs at time t_m ; for our example,

$$t_m = 0.408 \text{ sec} \quad \text{and} \quad e_m = 63.1 \text{ volts}$$

This maximum is larger than that obtained in the overdamped case and is a result of the smaller losses that occur in the larger resistor; the time of the maximum response is slightly later than it was with overdamping. The settling time may also be determined by solving

$$\frac{e_m}{100} = 420t_s\epsilon^{-2.45t_s}$$

for t_s (by trial-and-error methods),

$$t_s = 3.12 \text{ sec}$$

which is a considerably smaller value than arose in the overdamped case. As a matter of fact, it can be shown that, for given values of L and C , the selection of that value of R which provides critical damping will always give a shorter settling time than any choice of R which produces an overdamped response. However, a slight improvement (reduction) in settling time may be obtained by a further slight increase in resistance; a slightly underdamped response which will undershoot the zero axis before it dies out will yield the shortest settling time.

The response curve for critical damping is drawn in Fig. 8-4; it may be compared with the overdamped (and underdamped) case by reference to Fig. 8-6.

Drill Problem

8-5 Find $e(t)$ for each of the following cases if the damping is critical:

- (a) $C = 1$ farad, $L = 1$ henry, $e(0) = 0$, $i(0) = 10$ amp
- (b) $C = 1$ farad, $L = 1$ henry, $e(0) = 20$ volts, $i(0) = 10$ amp
- (c) $R = 10$ ohms, $C = 0.05$ farad, $e(0) = 20$ volts, $i(0) = 0$

Ans. $10t\epsilon^{-t}$ volts; $-10t\epsilon^{-t} + 20\epsilon^{-t}$ volts; $-20t\epsilon^{-t} + 20\epsilon^{-t}$ volts

8-5 THE UNDERDAMPED PARALLEL RLC CIRCUIT

Let us continue the process begun in the last section by increasing R once more. Thus, the damping coefficient α decreases while ω_0 remains constant, α^2 becomes smaller than ω_0^2 , and the radicand appearing in the expressions for s_1 and s_2 becomes negative. This causes the response to take on quite a different character, but it is fortunately not necessary to return to the basic differential equation again. By using complex numbers, the exponential response turns into a sinusoidal response; this response is composed entirely of real quantities, the complex quantities being necessary only for the derivation.⁴

We therefore begin with the exponential form

$$e(t) = A_1\epsilon^{s_1 t} + A_2\epsilon^{s_2 t}$$

where

$$s_{1,2} = -\alpha \pm \sqrt{\alpha^2 - \omega_0^2}$$

and then let

$$\sqrt{\alpha^2 - \omega_0^2} = \sqrt{-1} \sqrt{\omega_0^2 - \alpha^2} = j\sqrt{\omega_0^2 - \alpha^2}$$

⁴ An introduction to the use of complex numbers appears in Chap. 10. At that time we shall emphasize the more general nature of complex quantities by identifying them with boldface type; no special symbolism need be adopted in these few pages.

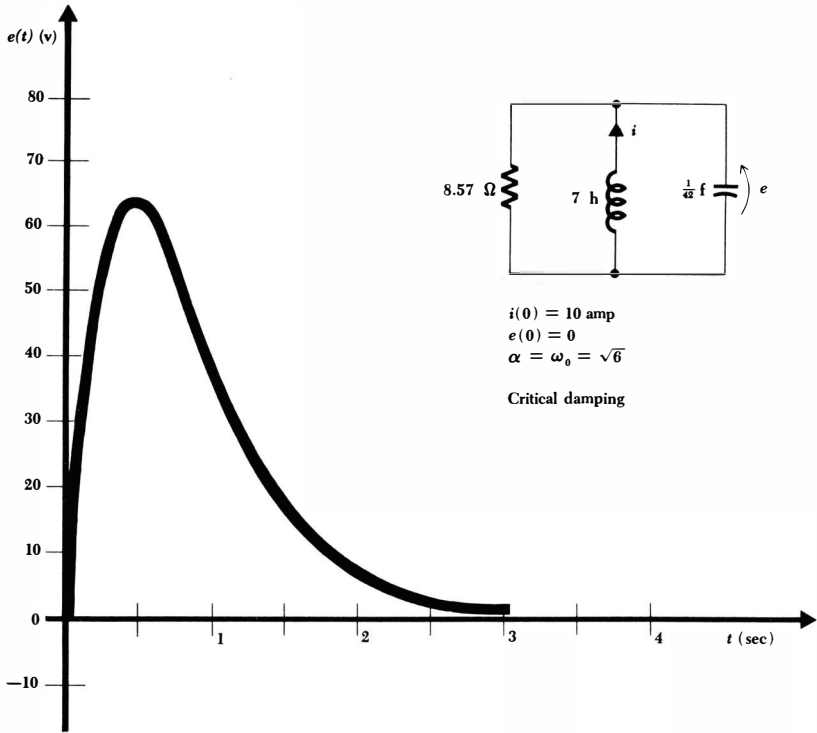

Fig. 8-4 The response $e(t) = 420t\epsilon^{-2.45t}$ of the network shown in Fig. 8-2 with R changed to provide critical damping.

where

$$j = \sqrt{-1}$$

We now take the new radical, which is real for the underdamped case, and call it ω_d , the *natural resonant frequency*,

$$\omega_d = \sqrt{\omega_0^2 - \alpha^2}$$

Collecting, the response may now be written as

$$e(t) = \epsilon^{-\alpha t} (A_1 e^{j\omega_d t} + A_2 e^{-j\omega_d t})$$

or in the longer but equivalent form,

$$e(t) = \epsilon^{-\alpha t} \left\{ (A_1 + A_2) \left[\frac{e^{j\omega_d t} + e^{-j\omega_d t}}{2} \right] + j(A_1 - A_2) \left[\frac{e^{j\omega_d t} - e^{-j\omega_d t}}{j2} \right] \right\}$$

Two of the most important identities in the field of complex numbers, identities which are later proved in Sec. 10-3, may now be readily applied. The first

244 The Transient Circuit

bracket in the above equation is identically equal to $\cos \omega_d t$, and the second bracket is identically $\sin \omega_d t$. Hence,

$$e(t) = \epsilon^{-\alpha t}[(A_1 + A_2) \cos \omega_d t + j(A_1 - A_2) \sin \omega_d t]$$

and the multiplying factors may be assigned new symbols,

$$e(t) = \epsilon^{-\alpha t}(B_1 \cos \omega_d t + B_2 \sin \omega_d t) \quad (8-20)$$

If we are dealing with the underdamped case, we have now left complex numbers behind. This is true since α , ω_d , and t are real quantities, $e(t)$ itself must be a real quantity (which might be presented on an oscilloscope, a voltmeter, or a sheet of graph paper), and thus B_1 and B_2 are real quantities. Equation (8-20) is the desired functional form for the underdamped response, and its validity may be checked by direct substitution into the original differential equation; this exercise is left to the doubters. The two real constants B_1 and B_2 are again selected to fit the given initial conditions.

Let us increase the resistance in our example from $7\sqrt{6}/2$ or 8.57 ohms to $10.5\sqrt{2}$ or 14.85 ohms; L and C are unchanged. Thus,

$$\alpha = \frac{1}{2RC} = \sqrt{2}$$

$$\omega_0 = \frac{1}{\sqrt{LC}} = \sqrt{6}$$

and $\omega_d = \sqrt{\omega_0^2 - \alpha^2} = 2$ (radians/sec)

Except for the evaluation of the arbitrary constants, the response is now known,

$$e(t) = \epsilon^{-\sqrt{2}t}(B_1 \cos 2t + B_2 \sin 2t)$$

The determination of the two constants proceeds as before. If we again assume that $e(0) = 0$ and $i(0) = 10$, then B_1 must be zero. Hence,

$$e(t) = B_2 \epsilon^{-\sqrt{2}t} \sin 2t$$

The derivative is

$$\frac{de}{dt} = 2B_2 \epsilon^{-\sqrt{2}t} \cos 2t - \sqrt{2}B_2 \epsilon^{-\sqrt{2}t} \sin 2t$$

and at $t = 0$ it becomes

$$\left. \frac{de}{dt} \right|_{t=0} = 2B_2 = \frac{i_C(0)}{C} = 420$$

Therefore,

$$e(t) = 210 \epsilon^{-1.414t} \sin 2t$$

Notice that, as before, this response function has an initial value of zero, because of the initial voltage condition we imposed, and a final value of zero, because the exponential term vanishes for large values of t . As t increases from

zero through small positive values, $e(t)$ increases as $210 \sin 2t$ because the exponential term remains essentially equal to unity. But at a time t_m , the exponential function begins to decrease more rapidly than $\sin 2t$ is increasing; so $e(t)$ reaches a maximum e_m and begins to decrease. We should note that t_m is not the value of t for which $\sin 2t$ is a maximum, but must occur somewhat before $\sin 2t$ reaches its maximum value. When $t = \pi/2$, $e(t)$ is zero; for the range $\pi/2 < t < \pi$ the response is negative, becoming zero again at $t = \pi$. Thus $e(t)$ is an *oscillatory* function of time and crosses the time axis an infinite number of times at $t = n\pi/2$, where n is any positive integer. In our example, however, the response is only slightly underdamped and the exponential term causes the function to die out so rapidly that most of the zero crossings will not be evident in a sketch.

The oscillatory nature of the response becomes more noticeable as α decreases. If α is zero, which corresponds to an infinitely large resistance, then $e(t)$ is an undamped sinusoid which oscillates with constant amplitude. This is not perpetual motion; we have merely assumed an initial energy in the circuit and have not provided any means to dissipate this energy. It is transferred from its initial location in the inductor to the capacitor, then returns to the inductor, and so on, forever. Actual parallel *RLC* circuits can be made to have effective values of R so large that a natural undamped sinusoidal response can be maintained for years without supplying any additional energy. We can also build active networks which introduce a sufficient amount of energy during each oscillation of $e(t)$ so that a sinusoidal response which is nearly perfect can be maintained for as long as we wish. This circuit is a sinusoidal oscillator, or signal generator, which is an important laboratory instrument.

Returning to our specific numerical problem, differentiation locates the first maximum of $e(t)$,

$$e_{m1} = 87.3 \text{ volts} \quad \text{at } t_{m1} = 0.478 \text{ sec}$$

the succeeding minimum,

$$e_{m2} = -9.47 \text{ volts} \quad \text{at } t_{m2} = 2.05 \text{ sec}$$

and so on. The response curve is shown in Fig. 8-5.

The settling time may be obtained by a trial-and-error solution, and it turns out to be 3.88 sec, a little larger than for critical damping. The second drill problem following this section demonstrates that the shortest settling time for this network results for slight underdamping.

The overdamped, critically damped, and underdamped responses for this network are shown on the same graph in Fig. 8-6. A comparison of these three curves makes these general conclusions plausible:

1. When the damping is changed by adjusting the size of the parallel resistance, the maximum magnitude of the response is greater with smaller damping.
2. The minimum settling time occurs approximately for critical damping; actually, the response should be slightly underdamped.

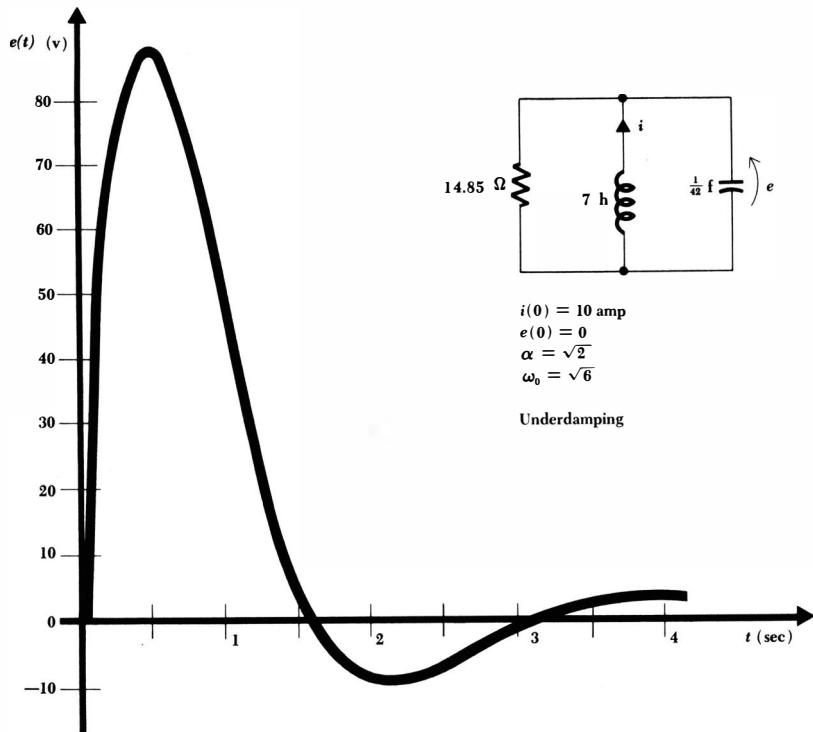

Fig. 8-5 The response $e(t) = 210\epsilon^{-1.414t} \sin 2t$ of the network shown in Fig. 8-2 with R increased to produce an underdamped response.

Drill Problems

8-6 Find $e(t)$ for a parallel RLC circuit in which $R = 25$ ohms, $L = 6$ henrys, $C = 1/50$ farad, and: (a) $e(0) = 0$, $i(0) = 2$ amp; (b) $e(0) = 100$ volts, $i(0) = 0$; (c) $e(0) = 100$ volts, $i(0) = 2$ amp. Is superposition applicable?

Ans. $100\epsilon^{-3t} \cos 4t$ volts; $\epsilon^{-3t}(100 \cos 4t - 75 \sin 4t)$ volts; $75\epsilon^{-3t} \sin 4t$ volts

8-7 The resistance of the underdamped parallel RLC circuit used as an example in the preceding section is decreased from 14.85 ohms to 10.5 ohms. Determine the following values of time: (a) t_{m1} , the time at which the first positive maximum of $e(t)$ occurs; (b) t_{01} , the time at which the first zero crossing of $e(t)$ occurs; (c) t_s , the settling time.

Ans. 2.22 sec; 2.93 sec; 0.435 sec

8-6 THE SOURCE-FREE SERIES RLC CIRCUIT

We now wish to determine the natural response of a circuit model composed of an ideal resistor, an ideal inductor, and an ideal capacitor connected in series. The ideal resistor may represent a physical resistor connected into a series LC or RLC circuit, it may represent the ohmic losses and the losses in the ferromagnetic core of the inductor, or it may be used to represent all these and other energy-absorbing devices. In a special case, the resistance of the ideal resistor may even be exactly equal to the measured resistance of the wire out of which the physical inductor is made.

The series RLC circuit is the dual of the parallel RLC circuit, and this single

Fig. 8-6 Three response curves for a parallel RLC circuit for which $\omega_0 = \sqrt{6}$, $e(0) = 0$, $i(0) = 10$ amp, and α is 3.5 (overdamped), 2.45 (critically damped), and 1.414 (underdamped).

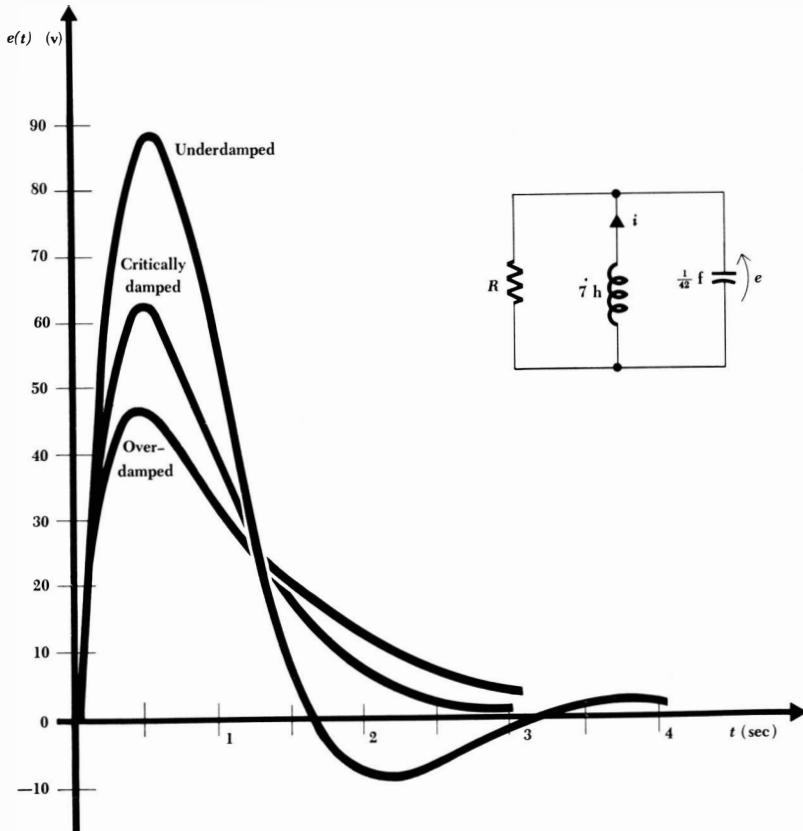

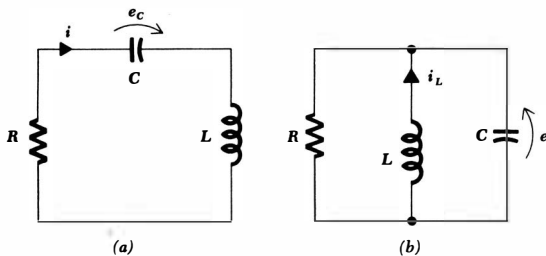

Fig. 8-7 (a) The series *RLC* circuit which is the dual of (b) the parallel *RLC* circuit. Element values are of course not identical in (a) and (b).

fact is sufficient to make its analysis a trivial affair. Figure 8-7a shows the series circuit. The fundamental integrodifferential equation is

$$L \frac{di}{dt} + Ri + \frac{1}{C} \int_{t_0}^t i dt - e_C(t_0) = 0$$

and should be compared with the analogous equation for the parallel *RLC* circuit, drawn again in Fig. 8-7b,

$$C \frac{de}{dt} + \frac{1}{R} e + \frac{1}{L} \int_{t_0}^t e dt - i_L(t_0) = 0$$

The second-order equations obtained by differentiating each of these equations with respect to time are also duals,

$$L \frac{d^2i}{dt^2} + R \frac{di}{dt} + \frac{i}{C} = 0 \quad (8-21)$$

$$C \frac{d^2e}{dt^2} + \frac{1}{R} \frac{de}{dt} + \frac{e}{L} = 0 \quad (8-22)$$

It is apparent that our complete discussion of the parallel *RLC* circuit is directly applicable to the series *RLC* circuit; the initial conditions on capacitor voltage and inductor current are equivalent to the initial conditions on inductor current and capacitor voltage; the voltage response becomes a current response. It is quite possible to reread the previous four sections (including the drill problems) using dual language and thereby obtain a complete description of the series *RLC* circuit.⁵ This process, however, is apt to induce a mild neurosis after the first few paragraphs and does not really seem to be necessary.

A brief résumé of the series circuit response is easily collected. In terms of the circuit shown in Fig. 8-7a, the underdamped response is

$$i(t) = A_1 e^{s_1 t} + A_2 e^{s_2 t}$$

⁵ In fact, during the writing of this text, the authors had originally written these first sections to describe the series *RLC* circuit. But, after deciding that it would be better to present the analysis of the more practical parallel *RLC* circuit first, it was easy to go back to the original writing and replace it with its dual. The numerical values of several of the elements were also scaled, a process described later in Chap. 15.

where

$$\begin{aligned} s_{1,2} &= -\frac{R}{2L} \pm \sqrt{\left(\frac{R}{2L}\right)^2 - \frac{1}{LC}} \\ &= -\alpha \pm \sqrt{\alpha^2 - \omega_0^2} \\ &= -\alpha \pm j\omega_d \end{aligned}$$

and thus

$$\begin{aligned} \alpha &= \frac{R}{2L} \\ \omega_0 &= \frac{1}{\sqrt{LC}} \\ \omega_d &= \sqrt{\omega_0^2 - \alpha^2} \end{aligned}$$

The form of the critically damped response is

$$i(t) = \epsilon^{-at}(A_1t + A_2)$$

and the underdamped case may be written

$$i(t) = \epsilon^{-at}(B_1 \cos \omega_d t + B_2 \sin \omega_d t)$$

It is evident that if we work in terms of the parameters α , ω_0 , and ω_d the mathematical forms of the responses for the dual situations are identical. An increase in α in either the series or parallel circuit, while keeping ω_0 constant, tends toward an overdamped response. The only caution that we need exert is in the computation of α , which is $1/2RC$ for the parallel circuit and $R/2L$ for the series circuit; thus, α is increased by increasing the series resistance or decreasing the parallel resistance.

As a numerical example, let us consider a series RLC circuit in which $L = 1$ henry, $R = 2$ ohms, $C = 1/401$ farad, $i(0) = 2$ amp, and $e_C(0) = 2$ volts. We find that α is unity and ω_0 is 20.02, and thus an underdamped response is indicated; we therefore calculate the value of ω_d and obtain 20. Except for the evaluation of the two arbitrary constants, the response is now known:

$$i(t) = \epsilon^{-t}(B_1 \cos 20t + B_2 \sin 20t)$$

By applying the initial value of the current, we find

$$B_1 = 2$$

and thus

$$i(t) = \epsilon^{-t}(2 \cos 20t + B_2 \sin 20t)$$

The remaining initial condition must be applied to the derivative; thus,

$$\begin{aligned} \frac{di}{dt} &= \epsilon^{-t}(-40 \sin 20t + 20B_2 \cos 20t - 2 \cos 20t - B_2 \sin 20t) \\ \left. \frac{di}{dt} \right|_{t=0} &= 20B_2 - 2 = \frac{e_L(0)}{L} = \frac{e_C(0) - i(0)R}{L} = \frac{2 - 4}{1} = -2 \end{aligned}$$

or

$$B_2 = 0$$

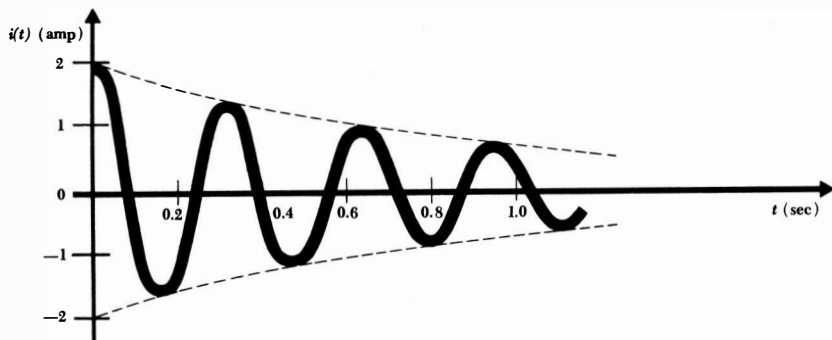

Fig. 8-8 The current response in an underdamped series RLC circuit for which $\alpha = 1$, $\omega_d = 20$, $i(0) = 2$ amp, and $e_c(0) = 2$ volts. The graphical construction is simplified by drawing in the envelopes, shown as broken lines.

The desired response is, therefore,

$$i(t) = 2e^{-t} \cos 20t$$

This response is more oscillatory, or shows less damping, than any we have considered up to this time, and the direct calculation of enough points to graph a smooth response curve is a tedious undertaking. A good sketch may be made by first drawing in the two exponential envelopes $2e^{-t}$ and $-2e^{-t}$, as shown by the broken lines in Fig. 8-8. The location of the quarter-cycle points of the sinusoidal wave at $20t = 0, \pi/2, \pi$, etc., or $t = 0.07854k$, $k = 0, 1, 2, \dots$, by light marks on the time axis then permits the oscillatory curve to be sketched in quickly.

Drill Problem

8-8 The switch in the circuit shown in Fig. 8-9 is opened at $t = 0$. Find $i(t)$ at $t = 0.1$ sec if: (a) $R = 52$ ohms; (b) $R = 20$ ohms; (c) $R = 12$ ohms.

Ans. -1.08 amp; -2.73 amp; -4.49 amp

8-7 THE COMPLETE RESPONSE OF THE RLC CIRCUIT

We must now consider those RLC circuits in which d-c sources are switched into the network and produce forced responses that do not vanish as time becomes infinite. The general solution is obtained by the same procedure that was followed in RL and RC circuits: the forced response is determined completely, the natural response is obtained as a suitable functional form containing the appropriate number of arbitrary constants, the complete response is written as the sum of the forced and the natural responses, and the initial conditions are then

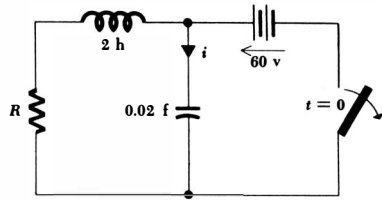

Fig. 8-9 See Drill Prob. 8-8.

determined and applied to the complete response to find the values of the constants. It is this last step which is quite frequently the most troublesome to students. Consequently, although the determination of the initial conditions is basically no different for a circuit containing d-c sources than it is for the source-free circuits which we have already covered in some detail, this topic will receive particular emphasis in the examples that follow.

Most of the confusion in determining and applying the initial conditions arises for the simple reason that we do not have laid down for us a rigorous set of rules to follow. At some point in each analysis there usually arises a situation in which some thinking is involved that is more or less unique to that particular problem. This originality and flexibility of thought, as simple as it is to achieve after several problems' worth of practice, is the source of the difficulty.

The complete response (arbitrarily assumed to be a voltage response) of a second-order system consists of a forced response, which is a constant for d-c excitation,

$$e_f(t) = E_f$$

and a natural response

$$e_n(t) = A\epsilon^{s_1 t} + B\epsilon^{s_2 t}$$

Thus,

$$e(t) = E_f + A\epsilon^{s_1 t} + B\epsilon^{s_2 t}$$

We shall now assume that s_1 , s_2 , and E_f have already been determined from the circuit and the given forcing functions; A and B remain to be found. The last equation shows the functional interdependence of A , B , e , and t , and substitution of the known value of e at $t = 0^+$ thus provides us with a single equation relating A and B . Another relationship between A and B is necessary, and this is normally obtained by taking the derivative of the response,

$$\frac{de}{dt} = 0 + s_1 A \epsilon^{s_1 t} + s_2 B \epsilon^{s_2 t}$$

and inserting in it the known value of de/dt at $t = 0^+$. There is no reason that this process cannot be continued; a second derivative might be taken, and a third relationship between A and B will then result if the value of d^2e/dt^2 at $t = 0^+$ is used. This value is *not* usually known, however, in a second-order system; as a matter of fact, we are much more likely to use this method to *find* the

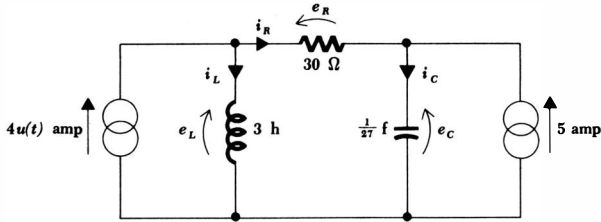

Fig. 8-10 An RLC circuit which is used to illustrate several procedures by which the initial conditions may be obtained. The desired response is nominally taken to be $e_c(t)$.

initial value of the second derivative if we should need it. We thus have only two equations relating A and B , and these may be solved simultaneously to evaluate the two constants.

The only remaining problem is that of determining the values of e and de/dt at $t = 0^+$. Since $i_C = C de_C/dt$, we should recognize the relationship between the initial value of de/dt and the initial value of some capacitor current. If we can establish a value for this initial capacitor current, then we shall automatically establish the value of de/dt . Students are usually able to get $e(0^+)$ very easily, but are inclined to stumble a bit in finding the initial value of de/dt . If we had selected a current as our response, then the initial value of di/dt must be intimately related to the initial value of some inductor voltage.

Let us illustrate the procedure by the careful analysis of the circuit shown in Fig. 8-10. Our object is to find the value of each current and voltage at both $t = 0^-$ and $t = 0^+$; with these quantities known, the required derivatives may be easily calculated. We shall employ a logical step-by-step method first.

At $t = 0^-$, only the right-hand current source is active. Moreover, the circuit is assumed to have been in this state forever, and all currents and voltages are constant. In other words, a steady-state condition has been reached and the resultant forced response has the form of the forcing function, its integral, and its derivatives. The integral of the forcing function, a linearly increasing function of time, is not present in this circuit, for it can occur only when a constant current is forced through a capacitor or a constant voltage is maintained across an inductor. This situation should not normally be present because the capacitor voltage or inductor current would assume an unrealistic infinite value at $t = 0^-$. Continuing, then, a constant current through the inductor requires zero voltage across it,

$$e_L(0^-) = 0$$

and a constant voltage across the capacitor requires zero current through it,

$$i_C(0^-) = 0$$

We then apply Kirchhoff's current law to the right node to obtain

$$i_R(0^-) = -5 \text{ amp}$$

253 The RLC Circuit

which also yields

$$e_R(0^-) = -150 \text{ volts}$$

We may now use Kirchhoff's voltage law around the central mesh, finding

$$e_C(0^-) = 150 \text{ volts}$$

while Kirchhoff's current law enables us to find the inductor current,

$$i_L(0^-) = 5 \text{ amp}$$

Although the derivatives at $t = 0^-$ are of little interest to us, it is evident that they are all zero.

Now let time increase an incremental amount. During the interval from $t = 0^-$ to $t = 0^+$, the left-hand current source becomes active and most of the voltage and current values at $t = 0^-$ will change abruptly. However, we should *begin by focusing our attention on those quantities which cannot change, inductor current and capacitor voltage*. Both of these must remain constant during the switching interval because there is no voltage impulse across the inductor and no current impulse through the capacitor. Thus,

$$i_L(0^+) = 5 \text{ amp} \quad \text{and} \quad e_C(0^+) = 150 \text{ volts}$$

Since two currents are now known at the left node, we next obtain⁶

$$i_R(0^+) = -1 \text{ amp} \quad \text{and} \quad e_R(0^+) = -30 \text{ volts}$$

Thus,

$$i_C(0^+) = 4 \text{ amp} \quad \text{and} \quad e_L(0^+) = 120 \text{ volts}$$

There remain six derivatives which might be evaluated, although not all are needed to evaluate the two arbitrary constants. The procedure must begin with the energy-storage elements by the direct application of their defining equations. For the inductor,

$$e_L = L \frac{di_L}{dt}$$

and, specifically,

$$e_L(0^+) = L \left. \frac{di_L}{dt} \right|_{t=0^+}$$

Thus,

$$\left. \frac{di_L}{dt} \right|_{t=0^+} = \frac{e_L(0^+)}{L} = 40 \text{ amp/sec}$$

⁶This current is the only one of the four remaining quantities which can be obtained in one step. In more complicated circuits, it is quite possible that none of the remaining initial values can be obtained with a single step; either circuit equations must then be written or a simpler equivalent resistive circuit must be drawn which can be analyzed by writing simultaneous equations. This latter method will be described shortly.

Similarly,

$$\left. \frac{de_C}{dt} \right|_{t=0^+} = \frac{i_C(0^+)}{C} = 108 \text{ volts/sec}$$

The other four derivatives may be determined by realizing that Kirchhoff's current and voltage laws are both satisfied by the derivatives also. For example, at the left node,

$$4 - i_L - i_R = 0 \quad t > 0$$

and thus

$$0 - \frac{di_L}{dt} - \frac{di_R}{dt} = 0 \quad t > 0$$

and, therefore,

$$\left. \frac{di_R}{dt} \right|_{t=0^+} = -40 \text{ amp/sec}$$

Now let us turn to a slightly different method by which all these currents, voltages, and derivatives may be evaluated at $t = 0^-$ and $t = 0^+$. We shall construct two equivalent circuits, one which is valid for the steady-state condition reached at $t = 0^-$ and a second which is valid during the switching interval. The discussion which follows relies on some of the reasoning we did above and, for that reason, appears shorter than it would be if it were presented first.

Prior to the switching operation, only direct currents and voltages exist in the circuit, and the inductor may therefore be replaced by a short circuit, its d-c equivalent, while the capacitor is replaced by an open circuit. Redrawn in this manner, the circuit of Fig. 8-10 appears as shown in Fig. 8-11*a*. The three voltages and three currents at $t = 0^-$ are now easily found by resistive circuit-analysis methods; the numerical values are the same as those found previously.

We now turn to the problem of drawing an equivalent circuit which will assist us in determining the several voltages and currents at $t = 0^+$. The absence of any impulse sources requires each capacitor voltage and each inductor current to remain constant during the switching interval. These conditions may be met by replacing the inductor by a current source and the capacitor by a voltage source. Each source serves to maintain the necessary response constant during the discontinuity. The equivalent circuit of Fig. 8-11*b* results; it should be noted that this circuit is a true equivalent at $t = 0^-$ since it possesses the same currents and voltages as the simple equivalent of Fig. 8-11*a*. It is also a true equivalent at $t = 0^+$ since the step-current source appears as a function of time and not merely as 0 amp or 4 amp.

The voltages and currents at $t = 0^+$ are obtained by letting $4u(t) = 4$ amp and solving the d-c circuit which results. The solution is not difficult, but the relatively large number of sources present in the network does produce a somewhat strange sight. However, problems of this type were solved in Chap. 3, and nothing new is involved. The six responses at $t = 0^+$ must agree with those found by the previous method.

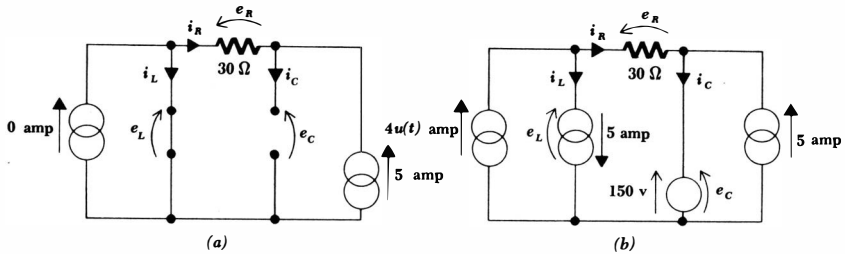

Fig. 8-11 (a) A simple circuit which is the equivalent of the circuit of Fig. 8-10 for $t = 0^-$. (b) Another equivalent of the circuit of Fig. 8-10, valid during the switching interval, $t = 0^-$ to $t = 0^+$.

Before leaving this problem of the determination of the necessary initial values, it should be pointed out that at least one other powerful method of determining them has been omitted; we could have written the general nodal equations for the original circuit. Then, the substitution of the known zero values of inductor voltage and capacitor current at $t = 0^-$ would uncover several other response values at $t = 0^-$ and enable the remainder to be found easily. A similar analysis at $t = 0^+$ must then be made. This is an important method, and it becomes a necessary one in more complicated circuits which cannot be analyzed by the step-by-step procedures we have followed. However, we must leave a few topics to be covered at the time operational methods of circuit analysis are introduced in later courses.

Now let us briefly complete the determination of the response $e_C(t)$ for the original circuit of Fig. 8-10. With both sources dead, the circuit appears as a series *RLC* circuit and s_1 and s_2 are easily found to be -1 and -9 , respectively. The forced response may be found by inspection or, if necessary, by drawing the d-c equivalent, which is similar to Fig. 8-11a, with the addition of a 4-amp current source. The forced response is 150 volts. Thus,

$$e_C(t) = 150 + A\epsilon^{-t} + B\epsilon^{-9t}$$

and $e_C(0^+) = 150 = 150 + A + B$

Then,

$$\frac{de_C}{dt} = -A\epsilon^{-t} - 9B\epsilon^{-9t}$$

and $\left. \frac{de_C}{dt} \right|_{t=0^+} = 108 = -A - 9B$

Finally,

$$A = 13.5 \quad B = -13.5$$

and $e_C(t) = 150 + 13.5(\epsilon^{-t} - \epsilon^{-9t})$

Impulse sources may also be present to represent initial conditions produced by some equivalent arrangement of sources and switches; impulse responses will be

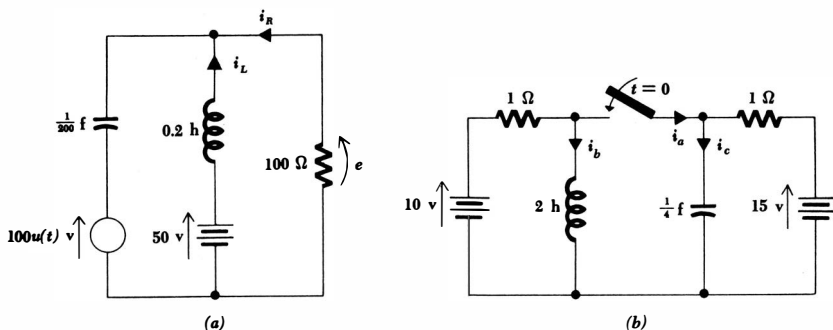

Fig. 8-12 (a) See Drill Probs. 8-9 and 8-10. (b) See Drill Prob. 8-11.

present in certain idealized circuits. Examples of these situations appear in Probs. 31 to 35.

Drill Problems

8-9 For the circuit shown in Fig. 8-12a, find: (a) $i_L(0^-)$; (b) $i_R(0^-)$; (c) $i_R(0^+)$.

Ans. 0.5 amp; -0.5 amp; -1.5 amp

8-10 For the circuit shown in Fig. 8-12a, find: (a) $e(0^-)$; (b) $e(0^+)$; (c) $e(t)$.

Ans. 150 volts; 50 volts; $50 + 3.16e^{-t}(31.6 \cos 31.6t - \sin 31.6t)$ volts

8-11 For the circuit shown in Fig. 8-12b, find, at $t = 0^+$: (a) di_b/dt ; (b) di_c/dt ; (c) di_a/dt .

Ans. 7.5 amp/sec; 52.5 amp/sec; 112.5 amp/sec

Problems

- 1 The general form of the natural response of the parallel RLC circuit is given by Eq. (8-9). Let $s_1 = -1$, $s_2 = -5$, and sketch $e(t)$ from $t = 0$ to $t = 3$ if: (a) $A_1 = 1$, $A_2 = 5$; (b) $A_1 = 5$, $A_2 = 1$; (c) $A_1 = -5$, $A_2 = 1$; (d) $A_1 = -1$, $A_2 = 5$.
- 2 (a) The circuit shown on the response curve of Fig. 8-3 is modified by decreasing the size of the capacitor to $\frac{1}{2}C$. If the initial conditions remain unchanged, find and sketch $e(t)$; compare with the response of the original circuit. (b) What will the response become if $C = 0$?
- 3 Determine the general expression for t_m , as a function of A_1 , A_2 , s_1 , and s_2 , for an overdamped RLC circuit.
- 4 In the circuit shown in Fig. 8-1, $C = 1$ farad and $L = \frac{1}{2}$ henry. (a) If $i(0) = 50$ amp and $e(t) = 12.5(\epsilon^{-4t} - \epsilon^{-8t})$, find R . (b) What total energy is dissipated in R ?

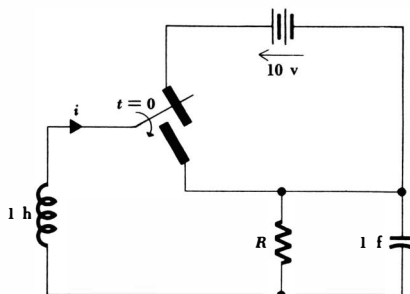

Fig. 8-13 See Prob. 5.

- 5 (a) If $R = 0.25$ ohm, find and sketch $i(t)$ for the circuit of Fig. 8-13. (b) Repeat if $R = 0.5$ ohm.
- 6 In order to obtain an example of a critically damped parallel RLC circuit in Sec. 8-4, the overdamped circuit of Sec. 8-3 was modified by changing its resistance. Instead, change the capacitance to provide critical damping. Compare t_m , e_m , and t_s for these two critically damped circuits.
- 7 A 10-mh coil, a $0.01\text{-}\mu\text{f}$ capacitor, and a 2000-ohm resistor are in parallel. (a) What value of resistance should be added in parallel to produce critical damping? (b) With this additional resistor in the circuit, find the response $e(t)$ if $e(0) = 0$ and $i_L(0) = 10$ ma. (c) Can the original circuit be made critically damped by adding inductance or capacitance in parallel? If so, determine the necessary element values.
- 8 A parallel RLC circuit contains a 1-ohm resistor, a $\frac{1}{4}$ -farad capacitor, and a $\frac{1}{8}$ -henry inductor; the initial voltage and current in the coil are 10 volts and -12 amp, assuming a passive sign convention. (a) Find the inductor voltage as a function of time. (b) Repeat part a if the resistance is increased to 100 ohms.
- 9 A 100-ohm resistor, an 8-henry inductor, and a 0.001-farad capacitor are connected in parallel. If the initial voltage and inductor current are $e(0) = 60$ volts and $i(0) = 0.3$ amp (sensed as in Fig. 8-1), find and sketch $e(t)$.
- 10 The switch in the circuit of Fig. 8-14 is closed at $t = 0$. Find and sketch $e(t)$ and $i(t)$.

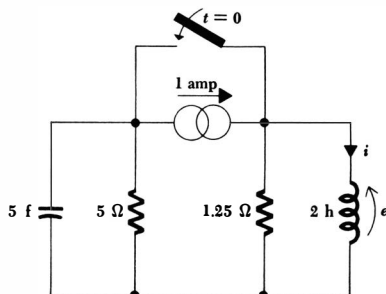

Fig. 8-14 See Prob. 10.

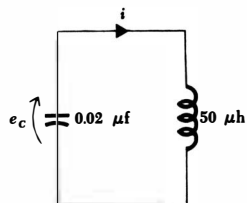

Fig. 8-15 See Prob. 11.

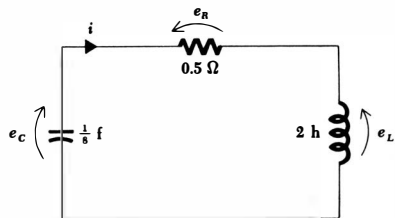

Fig. 8-16 See Prob. 12.

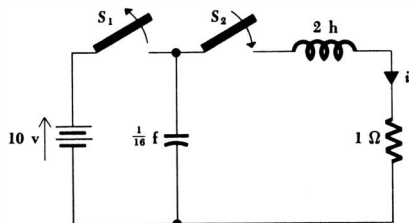

Fig. 8-17 See Prob. 13.

- ◆11 In the parallel LC circuit shown in Fig. 8-15, $e_C(0) = 100$ volts and $i(0) = 0$. (a) Find $i(t)$. (b) Find $e_C(t)$. (c) Show that the total energy stored in the circuit does not vary with time. Why must this be so?
- 12 In the series RLC circuit shown in Fig. 8-16, 1 joule of energy is stored initially in both the capacitor and the inductor. (a) Find $e_C(0)$ and $i(0)$ if both are assumed positive initially. (b) Find and sketch $i(t)$. (c) Find the first time greater than $t = 0$ at which $i(t) = 0$. (d) Find e_L and e_R at this instant. (e) Find e_C at this same time. (f) How much energy has been dissipated in the resistor from $t = 0$ up to this time?
- ◆13 In the circuit of Fig. 8-17, S_1 is opened at $t = 0$ and S_2 is closed at $t = 0$. Find $i(t)$ and determine the total energy dissipated in the 1-ohm resistor.
- 14 A 100-volt battery is connected to a series RLC circuit at $t = 0$. The current response is sketched in Fig. 8-18. Find R , L , and C .
- ◆15 The switch in the circuit shown in Fig. 8-19 has been closed for a long time. At 9:02 A.M. a student by the name of G. I. Hert opens switch S ; then at exactly 9:03 A.M. he begins dismantling the circuit by grasping point "a" firmly in one hand and point "b" firmly in the other. At what

time is the maximum current passing through his 30,000-ohm body, and how large is the current?

- 16 After the switch in the circuit of Fig. 8-20 is opened, the current response is given by $i(t) = 14.14e^{-2t} \cos(2t + \phi)$. Find R and ϕ .
- ◆17 In a series RLC circuit, $R = 100$ ohms, $L = 10$ mh, $C = 6.25$ μ f, the initial energy storage in the capacitor is 0.18 joule and no energy is initially stored in the inductor. (a) Find s_1 , s_2 , and $i(t)$. (b) Find the value of t , $t = t_m$, at which i is a maximum. (c) Find the energy stored in L and C at both $t = 0$ and $t = t_m$. (d) Find the settling time t_s .
- 18 A series RLC circuit is critically damped. The initial current is zero, but its initial rate of rise is 10 amp/sec; the initial capacitor voltage is 100 volts. (a) Find the inductance L . (b) If the maximum current occurs at $t = 1$ sec, find α , R , and C .

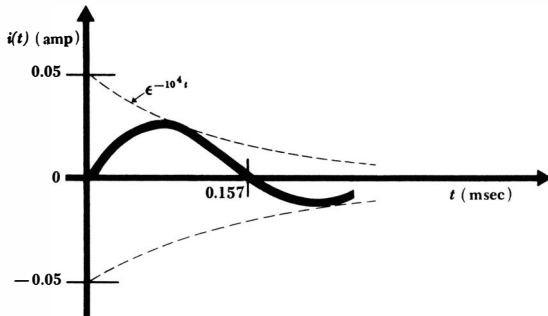

Fig. 8-18 See Prob. 14.

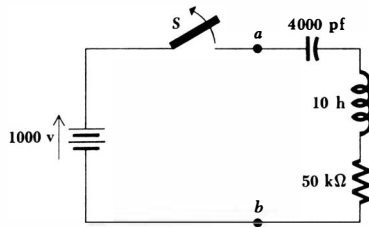

Fig. 8-19 See Prob. 15.

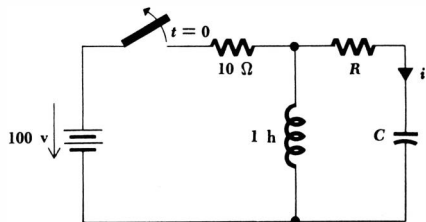

Fig. 8-20 See Prob. 16.

260 The Transient Circuit

- ◆19 Given a series RLC circuit in which $L = 1$ henry, $C = \frac{1}{2}$ farad, $R = 7$ ohms, $e(0) = 100$ volts, and $i(0) = 10$ amp, find $i(t)$.
- 20 Sketch $i(t)$ versus t on the same axes for the circuits shown in Fig. 8-21. Let $C = 1$ farad, $R = 20$ ohms, $e(0) = 100$ volts, $L = 1$ henry. In Fig. 8-21b, let $i(0) = 0$.
- ◆21 A series RLC circuit for which $L = 10$ mh, $R = 20$ ohms, and $C = 1/4.01 \mu\text{f}$ has $e_C(0) = 2$ volts, $i(0) = 0$. Find α , ω_0^2 , ω_d , $i(t)$, and sketch $i(t)$ versus t between -1 msec and 1 msec.

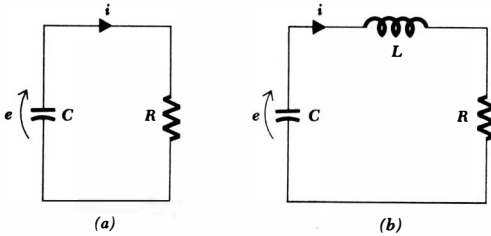

Fig. 8-21 See Prob. 20.

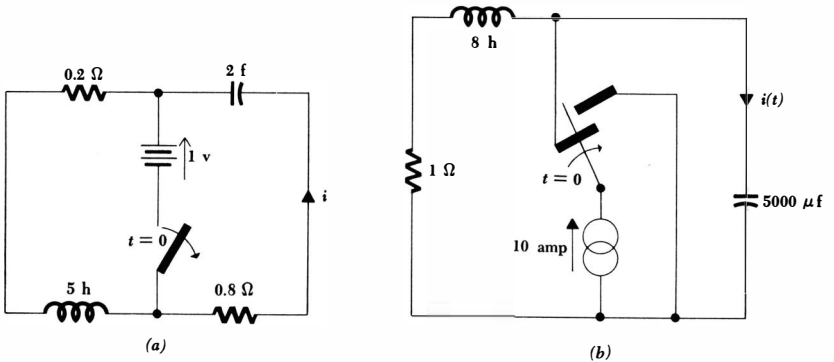
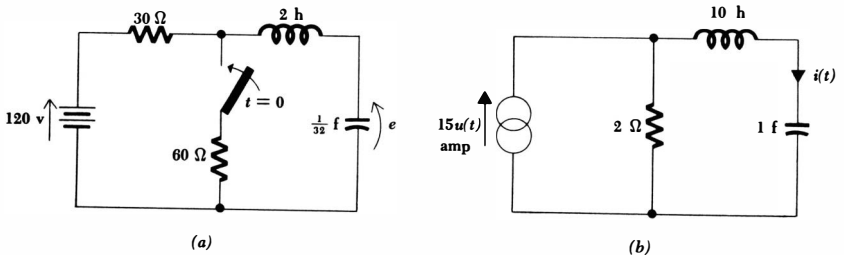

Fig. 8-22 (a) See Prob. 22. (b) See Prob. 23.

Fig. 8-23 (a) See Prob. 24. (b) See Prob. 25.



261 The RLC Circuit

- 22 In the circuit shown in Fig. 8-22a, the switch opens at $t = 0$. Find $i(t)$ for $t < 0$ and $t > 0$.
- 23 The switch in the circuit of Fig. 8-22b is thrown to the right at $t = 0$. Find $i(t)$.
- 24 The 60-ohm resistor is connected into the circuit of Fig. 8-23a at $t = 0$. Find $e(t)$ for $t < 0$ and $t > 0$.
- 25 Find $i(t)$ for the circuit of Fig. 8-23b.
- 26 For the circuit shown in Fig. 8-24a, show that $e(t) = 12e^{-t/6} - 12e^{-t/2}$ for $t > 0$.
- 27 Find $e(t)$ for the circuit shown in Fig. 8-24b.
- 28 Show that $e(t) = [15 + e^{-t}(-5 \sin 3t - 15 \cos 3t)]u(t)$ for the circuit shown in Fig. 8-25a.
- 29 Find $e(t)$ for the circuit shown in Fig. 8-25b.
- 30 The forced voltage response across a certain element in a moderately involved RLC circuit is 100 volts. The natural response for the voltage across this element is of the form $A_1e^{-t} + A_2e^{-2t} + A_3e^{-3t}$. The initial conditions for the total voltage across this element are

$$e(0^+) = 105 \text{ volts} \quad \left. \frac{de}{dt} \right|_{t=0^+} = -12 \text{ volts/sec} \quad \left. \frac{d^2e}{dt^2} \right|_{t=0^+} = 34 \text{ volts/sec}^2$$

Find $e(t)$.

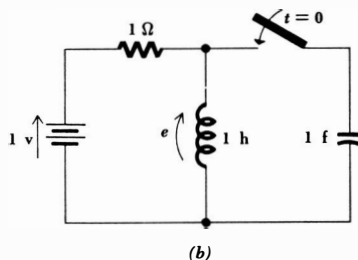
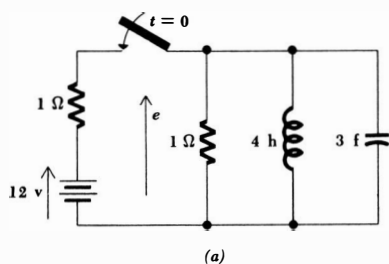
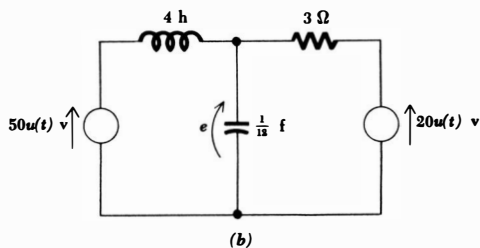
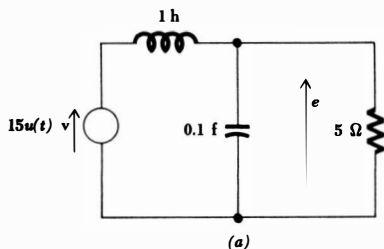

Fig. 8-24 (a) See Prob. 26. (b) See Prob. 27.

Fig. 8-25 (a) See Prob. 28. (b) See Prob. 29.



$20u(t)$ v

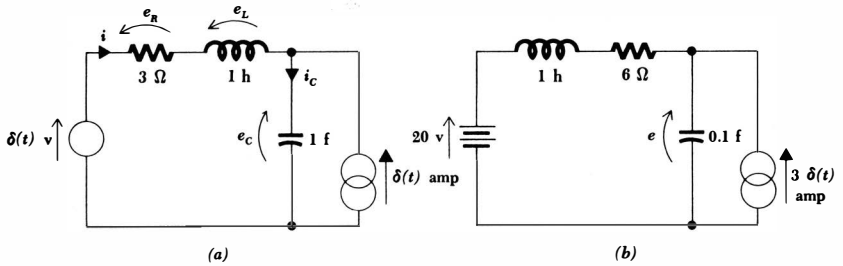
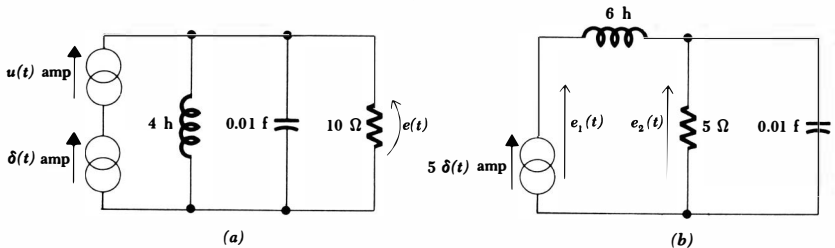

Fig. 8-26 (a) See Prob. 31. (b) See Prob. 32.

- 31 Find $i(t)$ for the circuit shown in Fig. 8-26a. Then, in order to check the answer, find successively $e_R(t)$, $e_L(t)$, $i_C(t)$, and $e_C(t)$; show that Kirchhoff's voltage law is satisfied around the left-hand mesh.
- ◆32 Find $e(t)$ for the circuit shown in Fig. 8-26b.
- 33 For the circuit shown in Fig. 8-27a, find $e(t)$.
- ◆34 Find $e_1(t)$ and $e_2(t)$ for the circuit shown in Fig. 8-27b.
- 35 A rectangular voltage pulse having an amplitude of 300 volts and a duration of $1 \mu\text{sec}$ is applied to a series RLC circuit. What are reasonable characteristics for the RLC circuit which will permit the pulse to be represented by an impulse? If $R = 100$ ohms, $C = 0.01 \mu\text{f}$, and $L = 10$ mh, determine the current response.
- 36 A mass m rests on a frictionless surface. A perfectly elastic spring that requires a force of K newtons to elongate it each meter is connected between the mass and a fixed reference point. Let the displacement of the mass from the reference point be x . (a) Let the velocity of the mass $v = dx/dt$ be the dependent variable and write the differential equation for this system. Compare with the lossless cases of Eqs. (8-21) and (8-22) and determine the natural resonant frequency ω_0 of the oscillatory motion. (b) Assume that a frictional retarding force (see Chap. 5, Prob. 7) is now present. Write the differential equation in terms of the velocity v for this system and, by comparison with Eq. (8-21), state the electric analog of v , m , the

Fig. 8-27 (a) See Prob. 33. (b) See Prob. 34.



263 **The RLC Circuit**

spring stiffness K , the friction coefficient d , and x . **(c)** Determine a second analog by comparison with Eq. (8-22).

- ◆37 A 10-kg mass is suspended below a fixed reference point by a spring having a stiffness of 50 newtons/m. The acceleration of gravity is 9.8 newtons/kg. **(a)** Determine the natural resonant frequency of this system. **(b)** If the amplitude of the oscillation is 20 cm and the mass is at its lowest point at $t = 0$, determine $v(t)$ and $x(t)$.

Part
Three:
Sinusoidal
Analysis

Chapter 9 *The Sinusoidal Forcing Function*

9-1 INTRODUCTION

The complete response of a linear electric circuit is composed of two parts, the natural response and the forced response. The first part of our study was devoted to the resistive circuit, in which only the forced response is required or present. For simplicity, we usually restricted our forcing functions to d-c sources, and we therefore became exceedingly familiar with the various techniques useful in finding the d-c forced response. We then passed on to the next part and considered the natural response of a number of different circuits containing one or two energy-storage elements. Without undue strain we were then able to determine the complete response of these circuits by adding the natural response, which is characteristic of the circuit and not of the forcing function, to the forced response produced by d-c forcing functions, the only forced response with which we are familiar. We are therefore now in a position where our mastery of the natural response is greater than our knowledge of the forced response.

In this third part of our study we shall extend our knowledge of the forced response by considering the sinusoidal forcing function.

Why should we select the sinusoidal forcing function as the second functional form to study? Why not the linear function, the exponential function, or a modified Bessel function of the second kind? There are many reasons for the choice of the sinusoid, and any one of them would probably be sufficient to lead us in this direction.

One of these reasons is apparent from the results of the preceding chapter; the natural response of an underdamped second-order system is a damped sinusoid, and if no losses are present it is a pure sinusoid. The sinusoid thus appears naturally (as does the negative exponential). Indeed, Nature in general seems to have a decidedly sinusoidal character; the motion of a pendulum, the bouncing of a ball, the vibration of a violin string, the political atmosphere in

any country, and the ripples on the surface of a stein of chocolate milk will always display a reasonably sinusoidal character.

Perhaps it was observations of these natural phenomena that led the great French mathematician Fourier to his discovery of the important analytical method embodied in the Fourier theorem. In Chap. 20 we shall see that this theorem enables us to represent most of the useful mathematical functions of time which repeat themselves f_0 times a second by the sum of an infinite number of sinusoidal time functions with frequencies that are integral multiples of f_0 ; the given periodic function $f(t)$ can also be approximated as closely as we wish by the sum of a finite number of such terms, even though a graph of $f(t)$ will look very nonsinusoidal. This decomposition of a periodic forcing function into a number of appropriately chosen sinusoidal forcing functions is a very powerful analytical method, for it enables us to superpose the partial responses produced by each sinusoidal component in order to obtain the desired response caused by the given periodic forcing function. Thus, another reason for studying the response to a sinusoidal forcing function is found in the dependence of other forcing functions on sinusoidal analysis.

A third reason is found in an important mathematical property of the sinusoidal function. Its derivatives and integrals are also all sinusoids.¹ Since the forced response takes on the form of the forcing function, its integral, and its derivatives, the sinusoidal forcing function will produce a sinusoidal forced response throughout a linear circuit. The sinusoidal forcing function thus allows a much easier mathematical analysis than does almost every other forcing function.

Finally, the sinusoidal forcing function has important practical applications. It is an easy function to generate and is the waveform used predominantly throughout the electric power industry; every electrical laboratory contains a number of sinusoidal generators which operate throughout frequency bands which may extend from a few cycles per second to several gigacycles per second.

Drill Problem

9-1 The Fourier theorem, presented in Chap. 20, shows that the periodic triangular waveform $e_1(t)$ shown in Fig. 9-1 and the following infinite sum of sine waves,

$$e_2(t) = \frac{8}{\pi^2} (\sin 2\pi t - \frac{1}{3^2} \sin 6\pi t + \frac{1}{5^2} \sin 10\pi t - \frac{1}{7^2} \sin 14\pi t + \dots)$$

are equal. As a partial check on this equality, determine the ratio of $e_1(t)$ to $e_2(t)$ at $t = 0.2$ sec if $e_2(t)$ is approximated by only: (a) one term of the infinite series; (b) three terms of the infinite series; (c) five terms of the infinite series.

Ans. 0.972; 0.996; 1.04

¹ We are using the term "sinusoid" collectively here to include cosinusoidal functions of time also. After all, a cosine function can be written as a sine function if the angle is increased by 90°

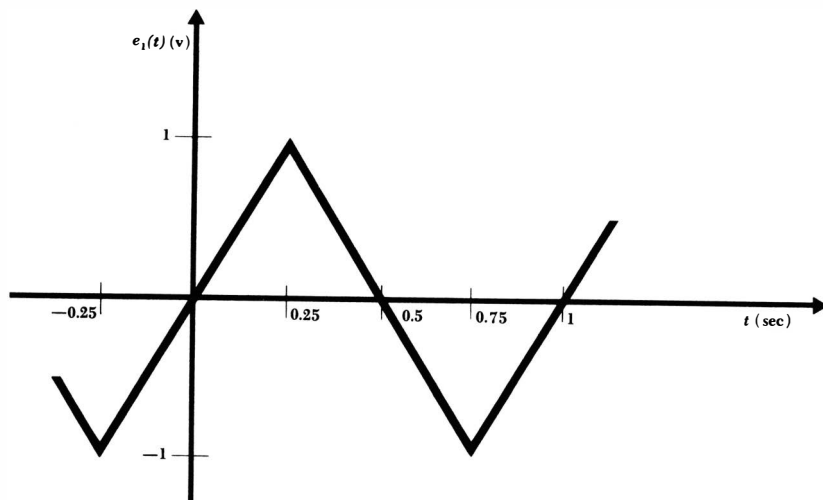

Fig. 9-1 See Drill Prob. 9-1.

9-2 CHARACTERISTICS OF SINUSOIDS

In this section we shall define the trigonometric nomenclature which is used to describe sinusoidal (or cosinusoidal) functions. The definitions should be familiar to most of us, and if we remember a little trigonometry, the section can be read over very rapidly.

Let us consider a sinusoidally varying voltage

$$e(t) = E_m \sin \omega t$$

shown graphically in Fig. 9-2a and b. The *amplitude* of the sine wave is E_m , and the *argument* is ωt . The *radian frequency* or *angular frequency* is ω . In Fig. 9-2a, $\sin \omega t$ is plotted as a function of the argument ωt , and the periodic nature of the sine wave is evident. The function repeats itself every 2π radians, and its *period* is therefore 2π radians. In Fig. 9-2b, $\sin \omega t$ is plotted as a function of t and the *period* is now T sec. The period may also be expressed in degrees, or occasionally in other units such as centimeters or inches. A sine wave having a period of T sec must execute $1/T$ periods each second; its *frequency* f is $1/T$ cycles per second, abbreviated cps. Thus,

$$f = \frac{1}{T}$$

and since

$$\omega T = 2\pi$$

we obtain the common relationship between frequency and radian frequency,

$$\omega = 2\pi f$$

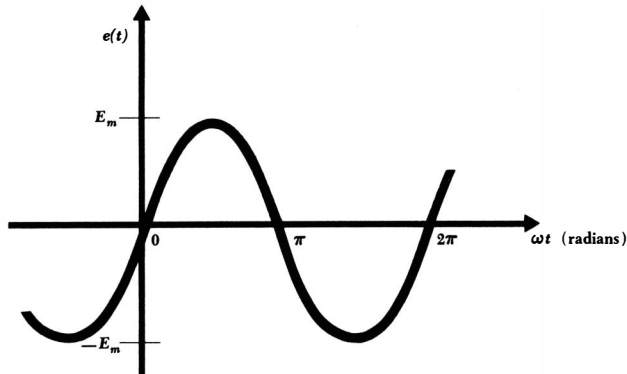

(a)

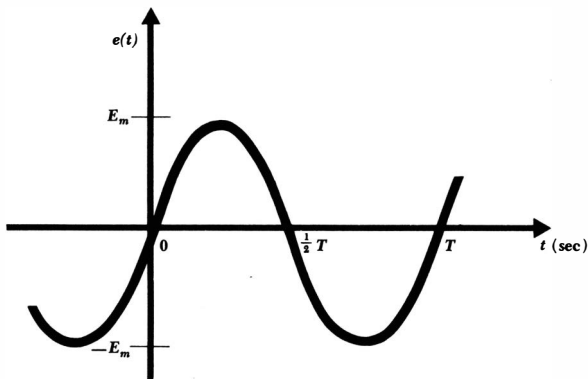

(b)

Fig. 9-2 The sinusoidal function $e(t) = E_m \sin \omega t$ is plotted versus ωt in (a) and versus t in (b).

A more general form of the sinusoid

$$e(t) = E_m \sin (\omega t + \theta) \quad (9-1)$$

includes a *phase angle* θ in its argument ($\omega t + \theta$). Equation (9-1) is plotted in Fig. 9-3 as a function of ωt , and the phase angle appears as the number of radians by which the original sine wave, shown as a broken line in the sketch, is shifted to the left, or earlier in time. Since corresponding points on the sinusoid $E_m \sin (\omega t + \theta)$ occur θ radians, or θ/ω sec, earlier, we say that $E_m \sin (\omega t + \theta)$ *leads* $E_m \sin \omega t$ by θ radians. Conversely, it is correct to describe $\sin \omega t$ as *lagging* $\sin (\omega t + \theta)$ by θ radians, as leading $\sin (\omega t + \theta)$ by $-\theta$ radians, or as leading $\sin (\omega t - \theta)$ by θ radians.

269 The Sinusoidal Forcing Function

In electrical engineering, the phase angle is commonly given in degrees, rather than radians, and no confusion will arise if the degree symbol is always used. Thus, instead of writing

$$e = 100 \sin\left(2\pi 1000t - \frac{\pi}{6}\right)$$

we customarily use

$$e = 100 \sin(2\pi 1000t - 30^\circ)$$

Two sinusoidal waves that are to be compared in phase must both be written as sine waves, or both as cosine waves; both waves must be written with positive amplitudes; and each must be of the same frequency. It is also evident that multiples of 360° may be added to or subtracted from the argument of any sinusoidal function without changing the value of the function. Hence, we may say that

$$e_1 = E_{m1} \sin(5t - 30^\circ)$$

lags

$$\begin{aligned} e_2 &= E_{m2} \cos(5t + 10^\circ) \\ &= E_{m2} \sin(5t + 90^\circ + 10^\circ) \\ &= E_{m2} \sin(5t + 100^\circ) \end{aligned}$$

by 130° , or it is also correct to say that e_1 leads e_2 by 230° , since e_2 may be written as

$$e_2 = E_{m2} \sin(5t - 260^\circ)$$

E_{m1} and E_{m2} are each assumed to be positive quantities. Normally, the difference in phase between two sinusoids is expressed by that angle which is smaller than 180° in magnitude.

The concept of a leading or lagging relationship between two sinusoids will be used extensively, and the relationship should be recognizable both mathematically and graphically.

Fig. 9-3 The sine wave $E_m \sin(\omega t + \theta)$ leads $E_m \sin \omega t$ by θ radians.

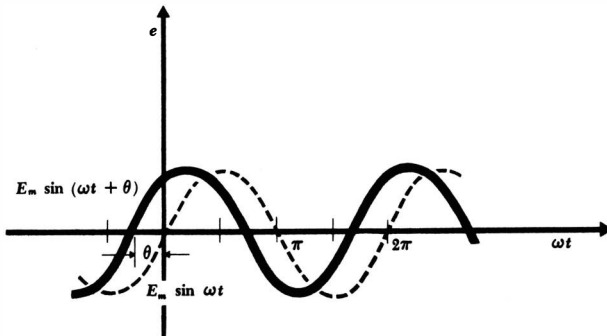

Drill Problems

9-2 The phase angle by which a sinusoidal voltage e_1 leads another sinusoidal voltage e_2 may be given as an angle θ , where $-180^\circ < \theta \leq 180^\circ$, the negative angles signifying that e_1 actually lags e_2 . Given that $e_1 = 60 \sin(100t - 50^\circ)$, find θ if $e_2 =$: (a) $20 \sin(100t + 20^\circ)$; (b) $40 \cos 100t$; (c) $-30 \cos(100t + 260^\circ)$.

Ans. -70° ; -140° ; 140°

9-3 The sum of a finite number of cosine and sine waves of the same frequency may always be expressed as a single sine or cosine wave including a phase angle. Express each of the following sums in the form $A \cos(5t - \theta)$, where $-180^\circ < \theta \leq 180^\circ$, by determining numerical values for A and θ : (a) $2 \sin 5t + 2 \cos 5t$; (b) $3 \cos 5t - 4 \sin 5t$; (c) $6 \cos(5t - 30^\circ) + 2 \sin 5t$.

Ans. 2.83, 45° ; 7.21, 43.9° ; 5.00, -53.1°

9-3 FORCED RESPONSE TO SINUSOIDAL FORCING FUNCTIONS

Now that we are familiar with the mathematical characteristics of sinusoids and can describe and compare them intelligently, we are ready to apply a sinusoidal forcing function to a simple circuit and to obtain the forced response. We shall first write the differential equation which applies to the given circuit. The complete solution of this equation is composed of two parts, the complementary solution (which we refer to as the natural response) and the particular integral (or forced response). The natural response is independent of the mathematical form of the forcing function and depends only upon the type of circuit, the element values, and the initial conditions. We find it by setting all the forcing functions equal to zero, thus reducing the equation to the simpler linear *homogeneous* differential equation. We have already determined the natural response of many *RL*, *RC*, and *RLC* circuits.

The forced response has the mathematical form of the forcing function, plus all its derivatives and its first integral. From this knowledge, it is apparent that one of the methods by which the forced response may be found is by assuming a solution composed of such a sum of functions, where each function has an unknown amplitude to be determined by direct substitution into the differential equation. This is a lengthy method, but it is the one which we shall use in this chapter to introduce sinusoidal analysis because it involves a minimum of new concepts. If the simpler method to be described in the following chapters were not available, circuit analysis would be an impractical, useless art.

The term *steady-state* response is used synonymously with forced response, and the circuits we are about to analyze are commonly said to be in the "sinusoidal steady state." Unfortunately, steady state carries the connotation of "not changing with time" in the minds of many students. This is true for d-c forcing functions, but the sinusoidal steady-state response is definitely changing with

time. The steady state simply refers to the condition which is reached after the transient or natural response has died out.

Now let us consider the series RL circuit shown in Fig. 9-4. The sinusoidal source voltage $e_s = E_m \cos \omega t$ has been switched into the circuit at some remote time in the past, and the natural response has died out completely. We seek the forced response, or steady-state response, and it must satisfy the differential equation

$$L \frac{di}{dt} + Ri = E_m \cos \omega t$$

The functional form of the forced response is next obtained by integration and repeated differentiation of the forcing function. Only two different forms are obtained, $\sin \omega t$ and $\cos \omega t$. The forced response must therefore have the general form

$$i(t) = I_1 \cos \omega t + I_2 \sin \omega t$$

where I_1 and I_2 are real constants whose values depend upon E_m , R , L , and ω . No constant or exponential function can be present. Substituting the assumed form for the solution into the differential equation yields

$$L(-I_1\omega \sin \omega t + I_2\omega \cos \omega t) + R(I_1 \cos \omega t + I_2 \sin \omega t) = E_m \cos \omega t$$

If we collect the cosine and sine terms, we obtain

$$(-LI_1\omega + RI_2) \sin \omega t + (LI_2\omega + RI_1 - E_m) \cos \omega t = 0$$

This equation must be true for all values of t , and this can be achieved only if the factors multiplying $\cos \omega t$ and $\sin \omega t$ are each zero. Thus,

$$-\omega LI_1 + RI_2 = 0 \quad \omega LI_2 + RI_1 - E_m = 0$$

and simultaneous solution for I_1 and I_2 leads to

$$I_1 = \frac{RE_m}{R^2 + \omega^2 L^2} \quad I_2 = \frac{\omega LE_m}{R^2 + \omega^2 L^2}$$

Thus, the forced response is obtained,

$$i(t) = \frac{RE_m}{R^2 + \omega^2 L^2} \cos \omega t + \frac{\omega LE_m}{R^2 + \omega^2 L^2} \sin \omega t \quad (9-2)$$

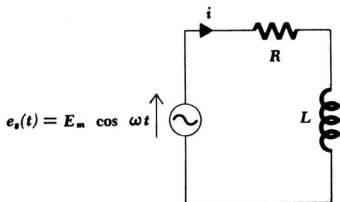

Fig. 9-4 A series RL circuit for which the forced response is desired.

This expression is slightly cumbersome, however, and a clearer picture of the response can be obtained by expressing the response as a single sinusoid or cosinusoid with a phase angle. Let us select the cosinusoid in anticipation of the method in the following chapter,

$$i(t) = A \cos(\omega t - \theta) \quad (9-3)$$

At least two methods of obtaining the values of A and θ should suggest themselves. We might substitute Eq. (9-3) directly into the original differential equation, or we could simply equate the two solutions (9-2) and (9-3). Let us select the latter method, since the former makes an excellent problem for the end of the chapter, and equate Eqs. (9-2) and (9-3) after expanding $\cos(\omega t - \theta)$,

$$A \cos \theta \cos \omega t + A \sin \theta \sin \omega t = \frac{RE_m}{R^2 + \omega^2 L^2} \cos \omega t + \frac{\omega LE_m}{R^2 + \omega^2 L^2} \sin \omega t$$

Thus, again collecting and setting the coefficients of $\cos \omega t$ and $\sin \omega t$ equal to zero, we find

$$A \cos \theta = \frac{RE_m}{R^2 + \omega^2 L^2} \quad \text{and} \quad A \sin \theta = \frac{\omega LE_m}{R^2 + \omega^2 L^2}$$

To find A and θ , we divide one equation by the other,

$$\frac{A \sin \theta}{A \cos \theta} = \tan \theta = \frac{\omega L}{R}$$

and by drawing a small triangle, as shown in Fig. 9-5, we have

$$\cos \theta = \frac{R}{\sqrt{R^2 + \omega^2 L^2}}$$

Thus,

$$A = \frac{1}{\cos \theta} \frac{RE_m}{R^2 + \omega^2 L^2} \quad \text{or} \quad A = \frac{E_m}{\sqrt{R^2 + \omega^2 L^2}}$$

The alternative form of the forced response therefore becomes

$$i(t) = \frac{E_m}{\sqrt{R^2 + \omega^2 L^2}} \cos \left(\omega t - \tan^{-1} \frac{\omega L}{R} \right) \quad (9-4)$$

The electrical characteristics of the response $i(t)$ should now be considered. The amplitude of the response is proportional to the amplitude of the forcing function; if it were not, our concept of linearity would have to be discarded.

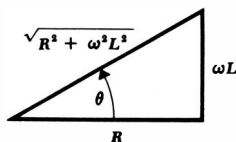

Fig. 9-5 A triangle drawn to display the relationship $\tan \theta = \omega L/R$ enables the value of $\cos \theta$ to be found.

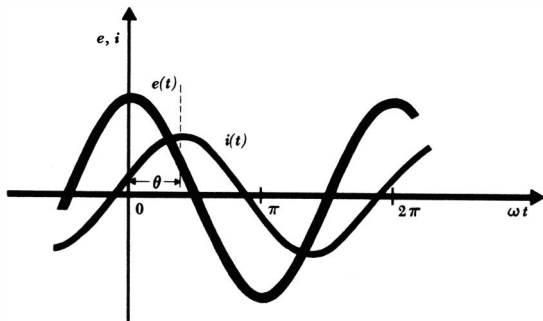

Fig. 9-6 The applied sinusoidal voltage forcing function and the resultant sinusoidal current response of the series RL circuit shown in Fig. 9-4.

The amplitude of the response also decreases as R , L , or ω is increased, but not proportionately. This is confirmed by the differential equation, for an increase in R , L , or di/dt requires a decrease in current amplitude if the source-voltage amplitude is not changed. The current is seen to lag the applied voltage by $\tan^{-1}(\omega L/R)$, an angle between 0° and 90° . When $\omega = 0$ or $L = 0$, the current must be in phase with the voltage; since the former situation is direct current and the latter provides a resistive circuit, the result is expected. If $R = 0$, the current lags the voltage by 90° ; then $e_s = L(di/dt)$, and the derivative-integral relationship between the sine and cosine indicates the validity of the 90° phase difference.

The applied voltage and the resultant current are both plotted on the same ωt axis in Fig. 9-6, but arbitrary current and voltage ordinates are assumed. The fact that the current lags the voltage in this simple RL circuit is now visually apparent. We shall later be able to show easily that this result is typical for all inductive circuits, that is, circuits composed only of inductors and resistors. The phase difference between the current and voltage depends upon the ratio of the quantity ωL to R . We call ωL the *inductive reactance* of the inductor; it is measured in ohms, and it is a measure of the opposition which is offered by the inductor to the passage of a sinusoidal current. Much more will be said about reactance in the following chapter.

The method by which we have found the sinusoidal steady-state response for this simple series RL circuit has not been a trivial problem. We might think of the analytical complications as arising through the presence of the inductor; if both the passive elements had been resistors, the analysis would have been ridiculously easy, even with the sinusoidal forcing function present. The reason the analysis would be so easy results from the simple voltage-current relationship specified by Ohm's law. The voltage-current relationship for an inductor is not as simple, however; instead of solving an algebraic equation, we were faced with a nonhomogeneous differential equation. It would be quite impractical to analyze every circuit by the method described above, and in the following chapter we shall therefore take steps to simplify the analysis. Our result will be an algebraic relationship between sinusoidal current and sinusoidal voltage for inductors and capacitors as well as resistors, and we shall be able to produce a set of alge-

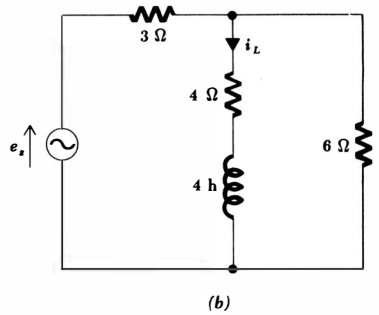
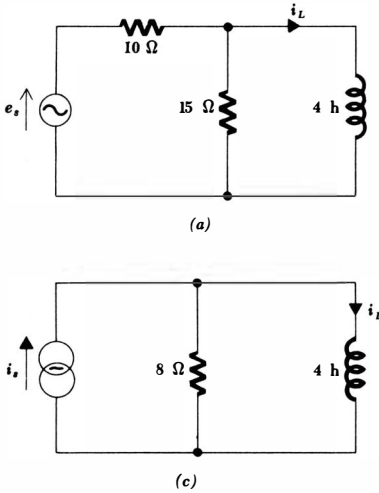

Fig. 9-7 See Drill Prob. 9-5.

braic equations for a circuit of any complexity. The constants and the variables in the algebraic equations will be complex numbers rather than real numbers, but the analysis of any circuit in the sinusoidal steady state becomes almost as easy as the analysis of a similar resistive circuit.

Drill Problems

9-4 Determine the amplitude and angle of lag of the sinusoidal current flowing in the circuit of Fig. 9-4 if:

- (a) $e_s = 100 \cos 2t$ volts, $R = 6$ ohms, $L = 4$ henrys
- (b) $e_s = 100 \cos 4t$ volts, $R = 6$ ohms, $L = 4$ henrys
- (c) $e_s = 100 \cos 4t$ volts, $R = 6$ ohms, $L = 2$ henrys

Ans. 10 amp, 53.1° ; 5.85 amp, 69.4° ; 10 amp, 53.1°

9-5 Apply Thévenin's theorem to find the amplitude and angle of lag of the inductor current i_L in the circuits shown in Fig. 9-7a, b, and c if $e_s = 100 \cos 2t$ volts and $i_s = 5 \cos 2t$ amp.

Ans. 6.67 amp, 53.1° ; 6 amp, 53.1° ; 3.54 amp, 45°

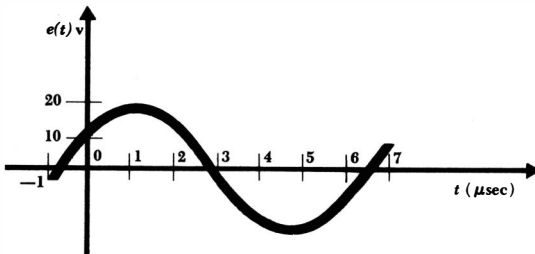

Fig. 9-8 See Prob. 1.

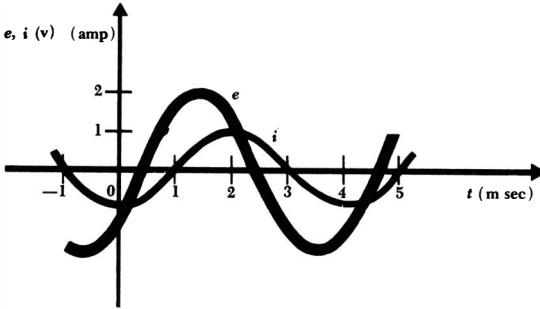

Fig. 9-9 See Prob. 3.

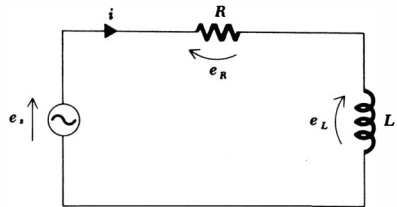

Fig. 9-10 See Prob. 4.

Problems

- ◆1 With reference to the sinusoidal voltage waveform shown in Fig. 9-8, find T , f , and ω . Write $e(t)$ as a cosine function including a phase angle, as a sine function including a phase angle, and also as the sum of a cosine and sine where neither includes a phase angle. By what angle does $e(t)$ lead $5 \cos [\omega(t + 2 \times 10^{-6})]$?
- 2 Substitute Eq. (9-3) into the differential equation describing the circuit of Fig. 9-4, and show that the result is identical with Eq. (9-4).
- ◆3 Express $e(t)$ and $i(t)$, as plotted in Fig. 9-9, in the form $A \cos (\omega t - \theta)$. If the voltage and current waveforms apply to a series RL circuit, find R and L .
- ◆4 A sinusoidal source $e_s = 50 \cos 200t$ is connected to a series combination of 30 ohms and 0.2 henry, as shown in Fig. 9-10. (a) Find i (steady state) as the sum of a term in $\cos 200t$ and one in $\sin 200t$. (b) Find i as a cosine function with a phase angle. (c) Find i as a sine function with a phase angle. (d) Sketch e_s and i on the same ωt axis. (e) Find e_R . (f) Find e_L . (g) Show that $e_s = e_R + e_L$.
- 5 Repeat Prob. 4 if $e_s = 50 \cos (200t + 120^\circ)$.
- 6 In the RC circuit shown in Fig. 9-11, let $e_s = E_m \cos \omega t$. (a) Show that $i_t = \frac{E_m}{\sqrt{R^2 + 1/\omega^2 C^2}} \cos \left(\omega t + \tan^{-1} \frac{1}{\omega CR} \right)$. (b) If $R = 30$ ohms, $C = \frac{1}{8000}$ farad, $\omega = 200$ radians/sec, $E_m = 50$ volts, evaluate i and sketch e_s and i on the same ωt axis. (c) Find e_R and e_C , and show that $e_s = e_R + e_C$.

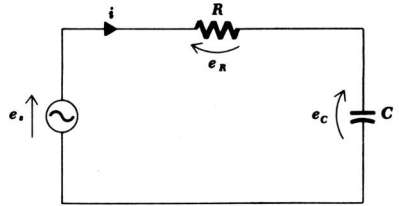

Fig. 9-11 See Prob. 6.

- ◆7 A small induction motor is represented by a resistance of 200 ohms in series with an inductance of 0.2 henry. The motor is energized by a 115-volt 60-cps voltage (the amplitude of the voltage is therefore $115\sqrt{2}$ volts, as discussed in Sec. 12-5). Find the amplitude of the current and the phase angle by which it lags the applied voltage.
- 8 In the circuit of Fig. 9-10 and Prob. 4, now assume that e_s is applied to the circuit at $t = 0$ and that there is no energy stored initially in the inductance. Find $i(t)$, including both the transient and steady-state components.
- ◆9 A current source $3 \cos 2t$ amp, a closed switch, a 3-ohm resistor, and a 2-henry inductor are all in parallel. The switch is opened at $t = 0$. Find the inductor voltage and current.
- 10 A voltage source $e_s = E_m \cos \omega t$ is in series with an inductance L and a capacitance C . Write the integrodifferential equation for this circuit. Assume a suitable functional form for the forced current $i(t)$ and determine the exact form by substitution into the integrodifferential equation. Assume that $\omega \neq 1/\sqrt{LC}$.
- 11 Knowing the forced response $i(t)$ for the circuit of Fig. 9-4, construct the dual circuit and specify its forced response. Apply Thévenin's theorem to this dual circuit and thus obtain the forced response given in Prob. 6, part a.

Chapter 10 *The Phasor Concept*

10-1 INTRODUCTION

Throughout the earlier portions of our study of circuit analysis, we devoted our entire attention to the resistive circuit. However, we might remember that we were often promised that those methods which we were applying to resistive circuits would later prove applicable to circuits containing inductors and capacitors as well. In this chapter we shall lay the descriptive groundwork which will make this prediction come true. We shall develop a method for representing a sinusoidal forcing function or a sinusoidal response by a complex-number symbolism called a phasor transform, or simply a phasor. This is nothing more than a number which, by specifying both the magnitude and phase angle of a sinusoid, characterizes that sinusoid just as completely as if it were expressed as an analytical function of time. By working with phasors, rather than with derivatives and integrals of sinusoids as we did in the preceding chapter, we shall affect a truly remarkable simplification in the steady-state sinusoidal analysis of general *RLC* circuits. This simplification should become apparent toward the end of this chapter.

The use of a mathematical transformation to simplify a problem should not be a new idea to us. For example, we have all used logarithms to simplify arithmetic multiplication and division. In order to multiply several numbers together, we first determined the logarithm of each of the numbers, or “transformed” the numbers into an alternative mathematical description. We might now describe that operation as obtaining the “logarithmic transform.” We then added all the logarithms to obtain the logarithm of the desired product. Then, finally, we found the antilogarithm, a process which might be termed an inverse transformation; the antilogarithm was our desired answer. Our solution carried us from the domain of everyday numbers to the logarithmic domain, and back again.

Other familiar examples of transform operations may be found in the alternative representations of a circle as a mathematical equation, as a geometric figure on a rectangular-coordinate plane, or merely as a set of three numbers, where it is understood that the first is the x -coordinate value of the center, the second is the y -coordinate value, and the third is the magnitude of the radius. Each of the three representations contains exactly the same information, and once the rules of the transformations are laid down in analytic geometry, we find no difficulty in passing from the algebraic domain to the geometric domain or to the "domain of the ordered triplet."

Few other transforms with which we are familiar provide the simplification that can be achieved with the phasor concept.

10-2 THE COMPLEX NUMBER

Some of us have certainly already learned the rudiments of the use of complex numbers in high school or in early mathematics courses in college. However, the subject is not a familiar one to all of us. The following several sections provide an adequate introduction to the topic and are sufficient for our purposes. Most students enjoy learning this material and do so with facility; there is really nothing that is complex about a complex number except its mathematical name.

Our early training in mathematics dealt exclusively with real numbers, such as 4, $-\frac{3}{4}$, and π . Soon, however, we began to encounter algebraic equations, such as $x^2 = -3$, which could not be satisfied by any real number. Such an equation can be solved only through the introduction of the *imaginary unit* or the *imaginary operator*, which we shall designate¹ by the symbol j . By definition, $j^2 = -1$, and thus $j = \sqrt{-1}$, $j^3 = -j$, $j^4 = 1$, and so forth. The product of a real number times the imaginary operator is called an *imaginary number*, and the sum of a real number and an imaginary number is called a *complex number*. Thus, a number having the form $a + jb$, where a and b are real numbers, is a complex number.²

We shall designate a complex number by means of a special single symbol; thus, $\mathbf{A} = a + jb$. The complex nature of the number is indicated by the use of bold-face type; in hand-written material, a dot or a bar over the letter is customary. The complex number \mathbf{A} above is described as having a *real component* or *real part* a and an *imaginary component* or *imaginary part* b . This is also expressed as

$$\text{Re} [\mathbf{A}] = a \quad \text{Im} [\mathbf{A}] = b$$

The imaginary component of \mathbf{A} is *not* jb . By definition, the imaginary component is a real number.

¹The mathematicians designate the imaginary operator by the symbol i , but it is customary to use j in electrical engineering in order to avoid confusion with the symbol for current.

²The choice of the words imaginary and complex is unfortunate. They are used here and in the mathematical literature as technical terms to designate a class of numbers. To interpret imaginary as "not pertaining to the physical world" or complex as "complicated" is neither justified nor intended.

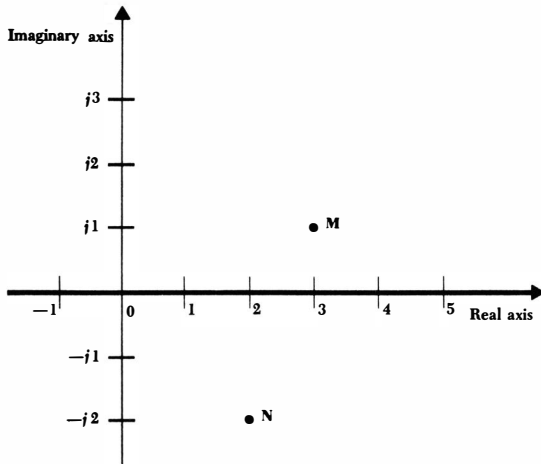

Fig. 10-1 The complex numbers $\mathbf{M} = 3 + j1$ and $\mathbf{N} = 2 - j2$ are shown on the complex plane.

It should be noted that all real numbers may be regarded as complex numbers having imaginary parts equal to zero. The real numbers are therefore included in the system of complex numbers, and we may now consider them as a special case. When we define the fundamental arithmetic operations for complex numbers, we should therefore expect them to reduce to the corresponding definitions for real numbers if the imaginary part of every complex number is set equal to zero.

Since any complex number is completely characterized by a pair of real numbers, such as a and b in the example above, we can obtain some visual assistance by representing a complex number graphically on a rectangular, or cartesian, coordinate system. By providing ourselves with a real axis and an imaginary axis, as shown in Fig. 10-1, we form a *complex plane* on which any complex number can be represented as a single point. The complex numbers $\mathbf{M} = 3 + j1$ and $\mathbf{N} = 2 - j2$ are indicated. It is important to understand that this complex plane is only a visual aid; it is not at all essential to the mathematical statements which follow.

We shall define two complex numbers as being equal if, and only if, their real parts are equal and their imaginary parts are equal. Graphically, then, to each point in the complex plane there corresponds only one complex number, and conversely, to each complex number there corresponds only one point in the complex plane. Thus, given the two complex numbers

$$\mathbf{A} = a + jb \quad \text{and} \quad \mathbf{B} = c + jd$$

then, if

$$\mathbf{A} = \mathbf{B}$$

it is necessary that

$$a = c \quad \text{and} \quad b = d$$

A complex number expressed as the sum of a real number and an imaginary number, such as $A = a + jb$, is said to be in *rectangular form*. Other forms for a complex number will appear shortly.

Let us now define the fundamental operations of addition, subtraction, multiplication, and division for complex numbers. The sum of two complex numbers is defined as the complex number whose real part is the sum of the real parts of the two complex numbers and whose imaginary part is the sum of the imaginary parts of the two complex numbers. Thus,

$$(a + jb) + (c + jd) = (a + c) + j(b + d)$$

For example,

$$(3 + j4) + (4 - j2) = 7 + j2$$

The difference of two complex numbers is taken in a similar manner; for example,

$$(3 + j4) - (4 - j2) = -1 + j6$$

Addition and subtraction of complex numbers may also be accomplished graphically on the complex plane. Each complex number is represented as a vector, or directed line segment, and the sum is obtained by completing the parallelogram, illustrated by Fig. 10-2a, or by connecting the vectors in a head-to-tail manner, as shown in Fig. 10-2b. A graphical sketch is often useful as a check for a more exact numerical solution.

The product of two complex numbers is defined by

$$(a + jb)(c + jd) = (ac - bd) + j(bc + ad)$$

This result may be easily obtained by the direct multiplication of the two binomial terms, using the rules of the algebra of real numbers, and then simplifying the result by letting $j^2 = -1$. For example,

$$\begin{aligned} (3 + j4)(4 - j2) &= 12 - j6 + j16 - 8j^2 \\ &= 12 + j10 + 8 \\ &= 20 + j10 \end{aligned}$$

It is easier to multiply the complex numbers by this method, particularly if we immediately replace j^2 by -1 , than it is to substitute into the general formula which defines the multiplication.

Before defining the operation of division for complex numbers, we should define the conjugate of a complex number. The *conjugate* of the complex number $A = a + jb$ is $a - jb$ and is represented as A^* . The conjugate of any complex number is therefore easily obtained by merely changing the sign of the imaginary part of the complex number. Thus, if

$$A = 5 + j3$$

then

$$A^* = 5 - j3$$

The definitions of addition, subtraction, and multiplication show that the following statements are true: the sum of a complex number and its conjugate is

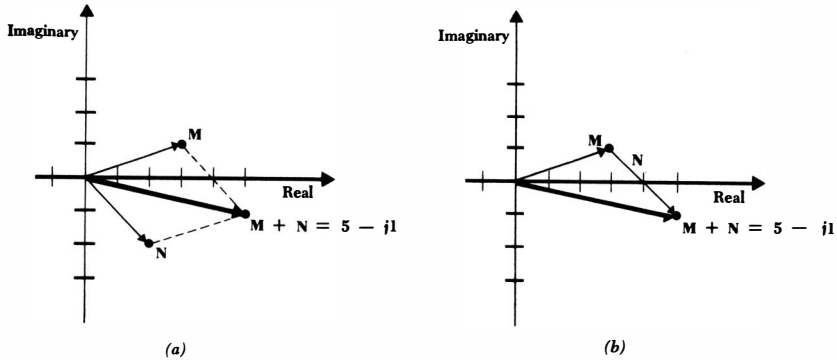

Fig. 10-2 (a) The sum of the complex numbers $\mathbf{M} = 3 + j1$ and $\mathbf{N} = 2 - j2$ is obtained by constructing a parallelogram. (b) The sum of the same two complex numbers is found by a head-to-tail combination.

a real number; the difference of a complex number and its conjugate is an imaginary number; and the product of a complex number and its conjugate is a real number. It is also evident that if \mathbf{A}^* is the conjugate of \mathbf{A} , then \mathbf{A} is the conjugate of \mathbf{A}^* ; in other words, $\mathbf{A} = (\mathbf{A}^*)^*$. A complex number and its conjugate are said to form a *conjugate complex pair* of numbers.

We now define the quotient of two complex numbers:

$$\frac{\mathbf{A}}{\mathbf{B}} = \frac{(\mathbf{A})(\mathbf{B}^*)}{(\mathbf{B})(\mathbf{B}^*)}$$

and thus

$$\frac{a + jb}{c + jd} = \frac{(ac + bd) + j(bc - ad)}{c^2 + d^2}$$

We multiply numerator and denominator by the conjugate of the denominator in order to obtain a denominator which is real; this process is called *rationalizing the denominator*. As a numerical example,

$$\begin{aligned} \frac{3 + j4}{4 - j2} &= \frac{(3 + j4)(4 + j2)}{(4 - j2)(4 + j2)} \\ &= \frac{4 + j22}{16 + 4} \\ &= 0.2 + j1.1 \end{aligned}$$

The addition or subtraction of two complex numbers which are each expressed in rectangular form is a relatively simple operation; multiplication or division of two complex numbers in rectangular form, however, is a rather unwieldy process. These latter two operations will be found to be much simpler when the complex numbers are given in either exponential or polar form. These forms will now be introduced.

Drill Problems

10-1 Given $\mathbf{A} = 3 + j2$, $\mathbf{B} = 1 - j3$, $\mathbf{C} = -2 + j1$, find: (a) $\mathbf{A} + \mathbf{B}$;
 (b) $4\mathbf{C} - 2\mathbf{B}$; (c) $\mathbf{A} - \mathbf{B} + \mathbf{C}$.

Ans. $4 - j1$; $0 + j6$; $-10 + j10$

10-2 Given $\mathbf{A} = 3 + j2$, $\mathbf{B} = 1 - j3$, $\mathbf{C} = -2 + j1$, find: (a) \mathbf{AB} ; (b)
 $(\mathbf{A} + \mathbf{B})(\mathbf{A} + \mathbf{C})$; (c) $j(\mathbf{A} + \mathbf{B})(3 + 2\mathbf{C})$.

Ans. $-9 - j2$; $9 - j7$; $7 + j11$

10-3 Given $\mathbf{A} = 3 + j2$, $\mathbf{B} = 1 - j3$, $\mathbf{C} = -2 + j1$, find: (a) \mathbf{AB}^* ;
 (b) $(\mathbf{AB})^*$; (c) $(\mathbf{A} + \mathbf{A}^*)(\mathbf{B} - \mathbf{B}^*)\mathbf{CC}^*$.

Ans. $9 + j7$; $-3 + j11$; $-j180$

10-4 Given $\mathbf{A} = 3 + j2$, $\mathbf{B} = 1 - j3$, $\mathbf{C} = -2 + j1$, find: (a) \mathbf{A}/\mathbf{B} ;
 (b) $(\mathbf{A} + \mathbf{B})/(\mathbf{B} + \mathbf{C})$; (c) $\mathbf{A}/[(\mathbf{C})(\mathbf{A} + \mathbf{C})]$.

Ans. $-0.3 + j1.1$; $-0.5 + j0.1$; $-0.4 + j1.8$

10-3 EULER'S IDENTITY

In this and the following chapters we shall begin to encounter functions of time which contain complex numbers, and we shall be concerned with the differentiation and integration of these functions. In most cases we shall be concerned with differentiating and integrating these functions with respect to the real variable t . In only a few isolated cases will we find it necessary to differentiate or integrate with respect to a complex variable. Neither of these cases requires any special treatment.

The operations of differentiation and integration with respect to complex variables are defined using the same limiting processes that are employed for real variables, and it can be shown in a straightforward manner that complex variables and complex constants can be treated just as though they were real variables or real constants when performing the operations of differentiation or integration. In other words, if $\mathbf{f}(t)$ is a complex function of time, such as

$$\mathbf{f}(t) = a \cos ct + jb \sin ct$$

then

$$\frac{d\mathbf{f}(t)}{dt} = -ac \sin ct + jbc \cos ct$$

and
$$\int \mathbf{f}(t) dt = \frac{a}{c} \sin ct - j \frac{b}{c} \cos ct + \mathbf{C}$$

where the constant of integration \mathbf{C} is a complex number in general. Since our intention is not to study mathematics per se, but only to learn how to apply it to our problems, we shall not consider the proofs of these statements on the extension of the differentiation and integration processes.

At this time we must make use of a very important fundamental relationship known as Euler's identity (pronounced "oilers"). Let us make an exception immediately to our ban on mathematical proofs and prove this identity, which will be extremely useful in representing a complex number in a form other than rectangular form. We begin by forming the complex quantity \mathbf{B} ,

$$\mathbf{B} = \cos \theta + j \sin \theta \quad (10-1)$$

where θ is a dimensionless real number expressed in radians. If we differentiate \mathbf{B} with respect to θ , we obtain

$$\frac{d\mathbf{B}}{d\theta} = -\sin \theta + j \cos \theta = j(\cos \theta + j \sin \theta)$$

$$\text{or, } \frac{d\mathbf{B}}{d\theta} = j\mathbf{B}$$

$$\text{and } \frac{d\mathbf{B}}{\mathbf{B}} = j d\theta \quad (10-2)$$

Now let us integrate each side of Eq. (10-2):

$$\ln \mathbf{B} = j\theta + \mathbf{C}$$

where \mathbf{C} is a complex constant of integration. We evaluate \mathbf{C} by returning to (10-1) and letting $\theta = 0$; thus, $\mathbf{B} = 1 + j0$ when $\theta = 0$. Hence, $\mathbf{C} = 0$, and

$$\ln \mathbf{B} = j\theta \quad \text{or} \quad \mathbf{B} = e^{j\theta}$$

and thus we obtain Euler's identity,

$$e^{j\theta} = \cos \theta + j \sin \theta \quad (10-3)$$

If we had begun with the conjugate of Eq. (10-1), we should have obtained an alternative form of Euler's identity,

$$e^{-j\theta} = \cos \theta - j \sin \theta \quad (10-4)$$

By adding and subtracting Eqs. (10-3) and (10-4), we obtain the two expressions which we used without proof in our study of the underdamped natural response of the parallel and series *RLC* circuits,

$$\cos \theta = \frac{1}{2}(e^{j\theta} + e^{-j\theta}) \quad (10-5)$$

$$\sin \theta = -j \frac{1}{2}(e^{j\theta} - e^{-j\theta}) \quad (10-6)$$

Another method whereby Euler's identity may be developed is through a comparison of the infinite power-series representations of $e^{j\theta}$, $\cos \theta$, and $\sin \theta$. This is outlined in Prob. 9.

Drill Problems

10-5 Use Euler's identity to determine the numerical value of: (a) e^{j1} ; (b) $\cos(j1)$; (c) $\sin(j1)$.

Ans. $0.540 + j0.842$; 1.543 ; $j1.175$

284 Sinusoidal Analysis

10-6 Since $\epsilon^{a+jb} = \epsilon^a \epsilon^{jb}$, Euler's identity also enables us to find the value of ϵ raised to any complex power. Evaluate: (a) ϵ^{1+j1} ; (b) $\epsilon^{-0.5+j0.5}$; (c) ϵ^{-2-j1} .

Ans. $0.073 - j0.114$; $0.532 + j0.291$; $1.469 + j2.29$

10-4 THE EXPONENTIAL FORM

Let us now take Euler's identity

$$\epsilon^{j\theta} = \cos \theta + j \sin \theta$$

and multiply each side by the real number C ,

$$C\epsilon^{j\theta} = C \cos \theta + jC \sin \theta \tag{10-7}$$

The right side of Eq. (10-7) consists of the sum of a real number and an imaginary number and thus represents a complex number in rectangular form; let us call this complex number \mathbf{A} , where $\mathbf{A} = a + jb$. By equating the real parts

$$a = C \cos \theta \tag{10-8}$$

and the imaginary parts

$$b = C \sin \theta \tag{10-9}$$

squaring and adding Eqs. (10-8) and (10-9),

$$a^2 + b^2 = C^2$$

$$\text{or } C = \sqrt{a^2 + b^2} \tag{10-10}$$

and dividing Eq. (10-9) by Eq. (10-8),

$$\frac{b}{a} = \tan \theta$$

$$\text{or } \theta = \tan^{-1} \frac{b}{a} \tag{10-11}$$

we obtain the relationships (10-10) and (10-11), which enable us to determine C and θ from a knowledge of a and b . For example, if $\mathbf{A} = 4 + j2$, then we identify a as 4 and b as 2 and find C and θ :

$$C = \sqrt{4^2 + 2^2} = 4.47$$
$$\theta = \tan^{-1} \frac{2}{4} = 26.6^\circ$$

We could use this new information to write \mathbf{A} in the form

$$\mathbf{A} = 4.47 \cos 26.6^\circ + j4.47 \sin 26.6^\circ$$

but it is the form of the left side of Eq. (10-7) which will prove to be the more useful:

$$\mathbf{A} = C\epsilon^{j\theta} = 4.47\epsilon^{j26.6^\circ}$$

A complex number expressed in this manner is said to be in *exponential form*. The real multiplying factor C is known as the *magnitude* or *amplitude* and the real quantity θ appearing in the exponent is called the *argument* or *angle*. A mathematician would always express θ in radians and would write

$$A = 4.47e^{j0.464}$$

but electrical engineers customarily work in terms of degrees. The use of the degree symbol ($^\circ$) in the exponent should make confusion impossible.

To recapitulate, if we have a complex number which is given in rectangular form,

$$A = a + jb$$

and wish to express it in exponential form,

$$A = Ce^{j\theta}$$

we may find C and θ by Eqs. (10-10) and (10-11). If we are given the complex number in exponential form, then we may find a and b by Eqs. (10-8) and (10-9).

One question will be found to arise in the determination of the angle θ by using the arc-tangent relationship (10-11). This function is multivalued, and an appropriate angle must be selected from various possibilities. One method by which the choice may be made is to select an angle for which the sine and cosine have the proper signs to produce the required values of a and b from Eqs. (10-8) and (10-9). For example, let us convert

$$E = 4 - j3$$

to exponential form. The amplitude is

$$C = \sqrt{4^2 + (-3)^2} = 5$$

and the angle is

$$\theta = \tan^{-1} \frac{-3}{4} \tag{10-12}$$

A value of θ must be selected which leads to a positive value for $\cos \theta$, since $4 = 5 \cos \theta$, and a negative value for $\sin \theta$, since $-3 = 5 \sin \theta$. We therefore obtain $\theta = -36.9^\circ, 323.1^\circ, -396.9^\circ$, and so forth. Any of these angles is correct, and we usually select that one which is the simplest, here -36.9° . We should note that the solution of Eq. (10-12), $\theta = 143.1^\circ$, is not correct because $\cos \theta$ is negative and $\sin \theta$ is positive.

A simpler method of selecting the correct angle is available if we represent the complex number graphically in the complex plane. Let us first select a complex number, given in rectangular form, $A = a + jb$, which lies in the first quadrant of the complex plane, as illustrated in Fig. 10-3. If we draw a line from the origin to the point which represents the complex number, we shall have constructed a right triangle whose hypotenuse is evidently the magnitude of the exponential representation of the complex number. In other words, $C = \sqrt{a^2 + b^2}$. Moreover, the counterclockwise angle which the line makes

Fig. 10-3 A complex number may be represented by a point in the complex plane by choosing the correct real and imaginary parts from the rectangular form, or by selecting the magnitude and angle from the exponential form.

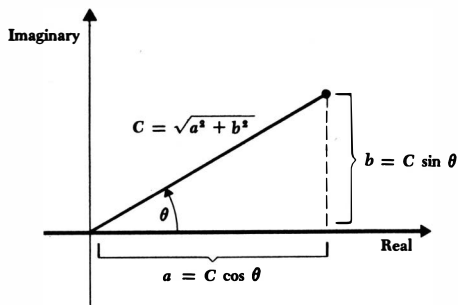

with the positive real axis is seen to be the angle θ of the exponential representation, because $a = C \cos \theta$ and $b = C \sin \theta$. Now if we are given the rectangular form of a complex number which lies in another quadrant, such as $\mathbf{E} = 4 - j3$, which is depicted in Fig. 10-4, the correct angle is graphically evident, either -36.9° or 323.1° for this example. The sketch may often be visualized and need not be drawn.

If the rectangular form of the complex number has a negative real part, it is often easier to work with the negative of the complex number, thus avoiding angles greater than 90° in magnitude. For example, given

$$\mathbf{I} = -5 + j2$$

we write

$$\mathbf{I} = -(5 - j2)$$

and then transform to exponential form,

$$\mathbf{I} = -C e^{j\theta}$$

where

$$C = \sqrt{29} = 5.39 \quad \text{and} \quad \theta = \tan^{-1} \frac{-2}{5} = -21.8^\circ$$

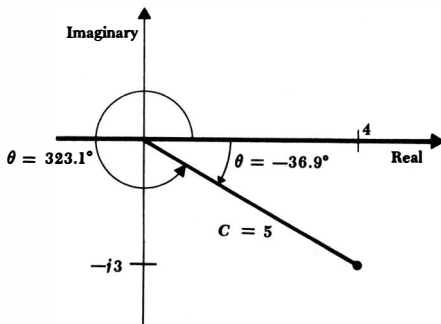

Fig. 10-4 The complex number $\mathbf{E} = 4 - j3 = 5e^{-j36.9^\circ}$ is represented in the complex plane.

287 The Phasor Concept

Thus, the exponential form of \mathbf{I} is

$$\mathbf{I} = -5.39e^{-j21.8^\circ}$$

The negative sign may be removed from the complex number by increasing or decreasing the angle by 180° , as shown by reference to a sketch in the complex plane. Thus, we may write

$$\mathbf{I} = 5.39e^{j158.2^\circ} \quad \text{or} \quad \mathbf{I} = 5.39e^{-j201.8^\circ}$$

Any of these three forms is acceptable.

One last remark about the exponential representation of a complex number should be made. Two complex numbers, both written in exponential form, are equal if, and only if, their magnitudes are equal and their angles are equivalent. Equivalent angles are those which differ by multiples of 360° . For example, if $\mathbf{A} = Ce^{j\theta}$ and $\mathbf{B} = De^{j\phi}$, then if $\mathbf{A} = \mathbf{B}$, it is necessary that $C = D$ and $\theta = \phi \pm 360^\circ n$, where $n = 0, 1, 2, 3, \dots$

Drill Problems

10-7 Transform to exponential form: (a) $6.43 + j7.66$; (b) $0 + j10$; (c) $-7.07 - j7.07$.

$$\text{Ans. } 10e^{-j135^\circ}; 10e^{j90^\circ}; 10e^{j90^\circ}$$

10-8 Transform to exponential form: (a) $(3 + j4)/(-4 - j3)$; (b) $2/(-0.6 + j0.8)$; (c) $(-1 + j2)/(-1 - j2)$.

$$\text{Ans. } 1e^{-j126.9^\circ}; 1e^{-j163.7^\circ}; 2e^{-j126.9^\circ}$$

10-5 THE POLAR FORM

The third (and last) form in which we may represent a complex number is essentially the same as the exponential form, except for a slight difference in symbolism. We use an angle sign (\angle) to replace the combination ($e^{j\theta}$). Thus, the exponential representation of a complex number \mathbf{A} ,

$$\mathbf{A} = Ce^{j\theta}$$

may be written somewhat more concisely as

$$\mathbf{A} = C/\underline{\theta}$$

The complex number is now said to be expressed in *polar* form, a name which suggests the representation of a point in a (complex) plane through the use of polar coordinates.

It is apparent that the transformation from rectangular to polar form or from polar form to rectangular form is basically the same as transformations between rectangular and exponential form. The same relationships exist between C , θ , a , and b .

The complex number

$$\mathbf{A} = 10 + j10$$

is thus written in exponential form as

$$\mathbf{A} = 14.14e^{j45^\circ}$$

and in polar form as

$$\mathbf{A} = 14.14/45^\circ$$

In order to appreciate the utility of the exponential and polar forms, let us consider the multiplication and division of two complex numbers represented in exponential or polar form. If we are given

$$\mathbf{A} = 5/53.1^\circ \quad \text{and} \quad \mathbf{B} = 15/-36.9^\circ$$

then the expression of these two complex numbers in exponential form

$$\mathbf{A} = 5e^{j53.1^\circ} \quad \mathbf{B} = 15e^{-j36.9^\circ}$$

enables us to write the product as a complex number in exponential form whose amplitude is the product of the amplitudes and whose angle is the algebraic sum of the angles, in accordance with the normal rules for multiplying two exponential quantities,

$$(\mathbf{A})(\mathbf{B}) = (5)(15)e^{j(53.1^\circ - 36.9^\circ)}$$

or
$$\mathbf{AB} = 75e^{j16.2^\circ}$$

From the definition of the polar form, it is evident that

$$\frac{\mathbf{A}}{\mathbf{B}} = 0.333/90^\circ$$

Addition and subtraction of complex numbers are accomplished most easily by operating on complex numbers in rectangular form, and the addition or subtraction of two complex numbers given in exponential or polar form should begin with the conversion of the two complex numbers to rectangular form. The reverse situation applies to multiplication and division; two numbers given in rectangular form should be transformed to polar form, unless the numbers happen to be small integers. For example, if we wish to multiply $(1 - j3)$ by $(2 + j1)$, it is easier to multiply them directly as they stand and obtain $(5 - j5)$. If the numbers can be multiplied mentally, then time is wasted in transforming them to polar form.

We should now endeavor to become familiar with the three different forms in which complex numbers may be expressed and with the rapid conversion from one form to another. The relationships between the three forms seem almost endless, and the following lengthy equation summarizes the various interrelationships:

$$\begin{aligned} \mathbf{A} &= a + jb = \text{Re}[\mathbf{A}] + j \text{Im}[\mathbf{A}] = Ce^{j\theta} = \sqrt{a^2 + b^2} e^{j \tan^{-1}(b/a)} \\ &= \sqrt{a^2 + b^2} / \tan^{-1}(b/a) = C \cos \theta + jC \sin \theta = C/\theta \end{aligned}$$

Most of the conversions from one form to another will be done with the help of

a slide rule. The transformation which we shall find most important to be able to achieve accurately and simply is that from rectangular to polar or exponential form. On most slide rules, this should *not* be done by finding the square root of the sum of the squares of the rectangular components. Each student should refer to his own slide-rule manual for the easiest technique. In case of confusion, help should be solicited from an instructor, a fellow classmate, or a friendly high school student.

Drill Problems

10-9 Work each of the following problems by performing all additions and subtractions in rectangular form and all multiplications and divisions in polar form. Convert from one form to another by slide rule. Express the answers in rectangular form.

$$(a) \frac{4.12/28^\circ + 3.12 - j0.918}{-1.704 + j1.068} \quad (b) \frac{28.6/137^\circ - 6.93/-23.7^\circ}{2.34 - j3.45}$$

$$(c) \frac{1}{1 + \frac{1}{1 + \frac{1}{1.111 + j1.876}}}$$

$$\text{Ans. } 2.08 + j1.497; 0.566 - j0.0766; -8.09 - j2.40$$

10-10 (a) Find the magnitude of $(2/0^\circ + 2/72^\circ + 2/144^\circ + 2/216^\circ + 2/288^\circ)$. (b) Find the real part of $\epsilon^{2/30^\circ}$. (c) Find the imaginary part of $3s/(s + 3)$ if $s = -2 + j3$.

$$\text{Ans. } 2.70; 3.05; 0$$

10-6 POWERS AND ROOTS

Although we shall not have any occasion to perform operations on complex numbers which are more advanced than those we have discussed, the definitions with which we are now familiar should enable us to take roots of complex numbers, raise them to any power, take logarithms, sines, and cosines of complex arguments, or perform any algebraic operation. Equations which we may have felt before had no solution will now be found to have a complex solution. For example, one solution of

$$\sin x = 2$$

$$\text{is } x = 1.571 + j1.317$$

and the solution of

$$y = \ln(-1)$$

$$\text{is } y = 0 + j(\pi \pm 2\pi n) \quad n = 0, 1, 2, 3, \dots$$

With the introduction of complex numbers, we now have a *complete* number system. The result of any algebraic manipulation of a complex number always yields a complex number. This statement is certainly not true for the real-number system.

In order to gain a little more familiarity with complex-number operations, let us raise a complex number to the n th power, where n is a positive integer. We express the number in exponential form,

$$A = C\epsilon^{j\theta}$$

raise both sides to the desired power,

$$(A)^n = (C\epsilon^{j\theta})^n$$

and obey the customary laws of algebra,

$$(A)^n = C^n \epsilon^{jn\theta}$$

The result is also simply expressed in rectangular form,

$$(A)^n = C^n \cos n\theta + jC^n \sin n\theta$$

For example,

$$(2 + j5)^3 = (5.39/\underline{68.2^\circ})^3 = 156.2/\underline{204.6^\circ}$$

Roots of complex numbers are obtained in a similar fashion. Thus, given

$$A = C\epsilon^{j\theta}$$

then

$$(A)^{1/n} = C^{1/n} \epsilon^{j\theta/n}$$

However, if the angle of A is written in an alternative, equivalent form by adding or subtracting multiples of 360° , then other answers also appear. If $k = 0, 1, 2, 3, \dots$, then A is expressible as

$$A = C\epsilon^{j(\theta \pm 2\pi k)}$$

and, thus,

$$(A)^{1/n} = C^{1/n} \epsilon^{j\left(\frac{\theta \pm 2k\pi}{n}\right)}$$

If n is an integer, then n distinct values of $(A)^{1/n}$ are obtained. For example, if

$$A = 8/\underline{120^\circ}$$

then

$$A^{1/3} = 8^{1/3}/\underline{40^\circ \pm 120^\circ k}$$

The three different answers are

$$\underline{2/40^\circ} \quad \underline{2/160^\circ} \quad \underline{2/280^\circ}$$

Other choices of the integer k lead to results which are equivalent to one of these three.

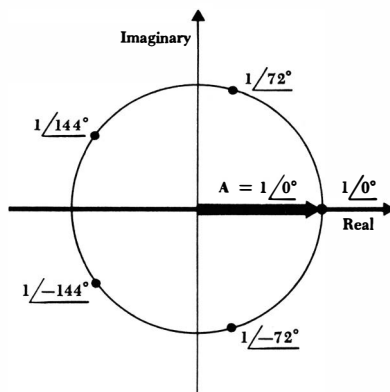

Fig. 10-5 A sketch showing the five different values of $(1)^{1/5}$.

A graphical interpretation of this process is enlightening. For simplicity, let us select $A = 1 + j0$, as shown in Fig. 10-5. The n different n th roots of unity are then found to lie on a circle of unit radius, centered at the origin; the roots are separated by $360^\circ/n$, with one root occurring at $1/0^\circ$. The sketch shows the case for $n = 5$.

Drill Problems

10-11 Evaluate and express in rectangular form: (a) $(0.65 - j1.05)^4$; (b) $(-0.8 + j0.6)^{10}$; (c) $(1 + j0.06)^{50}$.

Ans. $-1.083 + j0.157$; $0.988 - j0.1513$; $-1.401 + j1.856$

10-12 After finding all the roots in each part below, write them in the form $Ce^{j\theta}$, where $-180^\circ < \theta \leq 180^\circ$, and determine, for each part, that root for which $|\theta|$ is smallest. (a) $\sqrt{j100}$; (b) $(75 + j100)^{1/3}$; (c) $(j2)^{7/2}$.

Ans. $5e^{j17.7^\circ}$; $10e^{j45^\circ}$; $11.31e^{-j45^\circ}$

10-7 THE COMPLEX FORCING FUNCTION

Now that we are adept at understanding and algebraically manipulating complex numbers, we are ready to think about applying a complex forcing function to an electrical network. It may seem strange, but we shall find that the use of complex quantities in sinusoidal steady-state analysis leads to methods which are much simpler than those involving purely real quantities. We should expect a complex forcing function to produce a complex response; we might even suspect, and suspect correctly, that the real part of the forcing function will produce the real part of the response, while the imaginary portion of the forcing function will result in the imaginary portion of the response. Our goal in this section will be proving, or at least demonstrating, that these suspicions are correct.

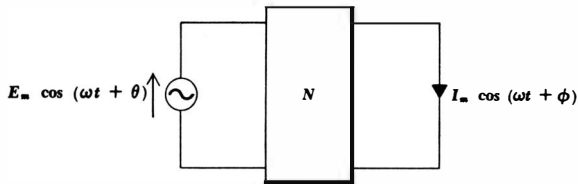

Fig. 10-6 The sinusoidal forcing function $E_m \cos(\omega t + \theta)$ produces the steady-state response $I \cos(\omega t + \phi)$.

Let us first discuss the problem in rather general terms, thus indicating the method by which we might prove our assertions if we were to construct a general network and to analyze it by a set of simultaneous equations and their determinant solution. In Fig. 10-6, a sinusoidal source

$$E_m \cos(\omega t + \theta) \quad (10-13)$$

is connected to a general network, which we shall arbitrarily assume to be **passive** in order to avoid complicating our use of the superposition principle later. A current response in some other branch of the network is to be determined. The parameters appearing in (10-13) are all real quantities.

The discussion in Chap. 9 of the method whereby the response to a sinusoidal forcing function may be determined, through the assumption of a sinusoidal form with arbitrary amplitude and arbitrary phase angle, shows that the response may be represented by

$$I_m \cos(\omega t + \phi) \quad (10-14)$$

A sinusoidal forcing function always produces a sinusoidal forced response.

Now let us change our time reference by shifting the phase of the forcing function by 90° (or temporarily replacing t by $t' - \pi/2\omega$). Thus, the forcing function

$$E_m \cos(\omega t + \theta - 90^\circ) \quad (10-15)$$

when applied to the same network will produce a corresponding response

$$I_m \cos(\omega t + \phi - 90^\circ) \quad (10-16)$$

If we represent these two sinusoids as sine waves, then the forcing function

$$E_m \sin(\omega t + \theta) \quad (10-17)$$

produces the response

$$I_m \sin(\omega t + \phi) \quad (10-18)$$

We must next depart from physical reality by applying an imaginary forcing function, one which cannot be applied in the laboratory, but one which can be applied mathematically. We should not feel that we are suddenly forsaking practical electrical engineering for some exotic theoretical study; it merely happens to be much easier to analyze real circuits through the use of imaginary and complex sources and responses. Our goal will consistently be a real answer.

We construct an imaginary source very simply; it is only necessary to multiply the source, expressed by (10-17), by j , the imaginary operator. We thus apply the source

$$jE_m \sin(\omega t + \theta) \quad (10-19)$$

What is the response? If we had doubled the source, then the principle of linearity would require that we double the response; multiplication of the forcing function by a constant k would result in the multiplication of the response by the same constant k . The fact that this constant is the imaginary operator j does not destroy this relationship, even though our earlier definition and discussion of linearity did not specifically include complex constants. It is now more realistic to conclude that it did not specifically *exclude* them, for the entire discussion is equally applicable if all the constants in the equations are complex. The response to the imaginary source of (10-19) is thus

$$jI_m \sin(\omega t + \phi) \quad (10-20)$$

The imaginary source and response are indicated in Fig. 10-7.

We have applied a real source and obtained a real response; we have also applied an imaginary source and obtained an imaginary response. Now let us use the superposition theorem to find the response to the complex forcing function which is the sum of the real and imaginary forcing functions. The applicability of superposition, of course, is guaranteed by the linearity of the circuit and does not depend on the form of the forcing functions; once we have permitted the imaginary or complex source, then we must accept the superposition principle for imaginary or complex sources. The sum of the forcing functions of (10-13) and (10-19),

$$E_m \cos(\omega t + \theta) + jE_m \sin(\omega t + \theta) \quad (10-21)$$

must therefore produce a response which is the sum of (10-14) and (10-20),

$$I_m \cos(\omega t + \phi) + jI_m \sin(\omega t + \phi) \quad (10-22)$$

The complex source and response may be represented more simply by applying Euler's identity. The source of (10-21) thus becomes

$$E_m e^{j(\omega t + \theta)} \quad (10-23)$$

Fig. 10-7 The imaginary forcing function $jE_m \sin(\omega t + \theta)$ produces the imaginary response $jI_m \sin(\omega t + \phi)$.

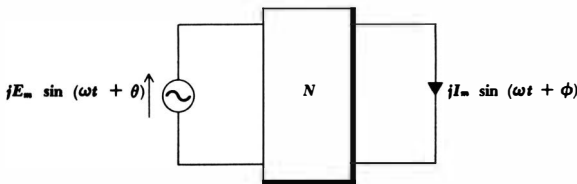
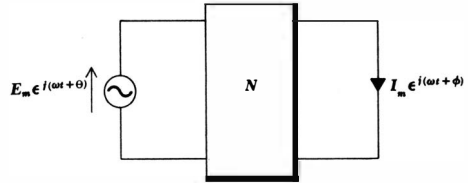

Fig. 10-8 The complex forcing function $E_m e^{j(\omega t + \theta)}$ produces the complex response $I_m e^{j(\omega t + \phi)}$ in the network of Fig. 10-6.



and the response of (10-22) is

$$I_m e^{j(\omega t + \phi)} \quad (10-24)$$

The complex source and response are illustrated in Fig. 10-8.

There are several important conclusions to be drawn from this general example. A real, an imaginary, or a complex forcing function will produce a real, an imaginary, or a complex response, respectively. Moreover, a complex forcing function may be considered, by the use of the superposition theorem, as the sum of a real and an imaginary forcing function; thus the real part of the complex response is produced by the real part of the complex forcing function, while the imaginary part of the response is caused by the imaginary part of the complex forcing function.

Instead of applying a real forcing function to obtain the desired real response, we shall apply a complex forcing function whose real part is the given real forcing function; we shall obtain a complex response whose real part is the desired real response. Through this procedure, the integrodifferential equations describing the steady-state response of a circuit will become simple algebraic equations.

Let us try out this idea on the simple RL series circuit shown in Fig. 10-9. The real source $E_m \cos \omega t$ is applied; the real response $i(t)$ is desired.

We first construct the complex forcing function which, upon the application of Euler's identity, yields the given real forcing function. Since

$$\cos \omega t = \operatorname{Re} e^{j\omega t}$$

then the necessary complex source is

$$E_m e^{j\omega t}$$

The complex response which results is expressed in terms of an unknown amplitude I_m and an unknown phase angle ϕ ,

$$I_m e^{j(\omega t + \phi)}$$

Writing the differential equation for this particular circuit,

$$Ri + L \frac{di}{dt} = e_s$$

we insert our complex expressions for e_s and i ,

$$RI_m e^{j(\omega t + \phi)} + L \frac{d}{dt} (I_m e^{j(\omega t + \phi)}) = E_m e^{j\omega t}$$

295 The Phasor Concept

take the indicated derivative,

$$RI_m\epsilon^{j(\omega t+\phi)} + j\omega LI_m\epsilon^{j(\omega t+\phi)} = E_m\epsilon^{j\omega t}$$

and obtain a complex algebraic equation. In order to determine the value of I_m and ϕ , we divide throughout by the common factor $\epsilon^{j\omega t}$,

$$RI_m\epsilon^{j\phi} + j\omega LI_m\epsilon^{j\phi} = E_m \tag{10-25}$$

factor the left side,

$$I_m\epsilon^{j\phi}(R + j\omega L) = E_m$$

rearrange,

$$I_m\epsilon^{j\phi} = \frac{E_m}{R + j\omega L}$$

and identify I_m and ϕ by expressing the right side of the equation in exponential or polar form,

$$I_m\epsilon^{j\phi} = \frac{E_m}{\sqrt{R^2 + \omega^2 L^2}} \epsilon^{j[-\tan^{-1}(\omega L/R)]} \tag{10-26}$$

Thus,

$$I_m = \frac{E_m}{\sqrt{R^2 + \omega^2 L^2}}$$

and
$$\phi = -\tan^{-1} \frac{\omega L}{R}$$

The complex response is given by Eq. (10-26). The real response $i(t)$ may be obtained by reinserting the $\epsilon^{j\omega t}$ factor on both sides of Eq. (10-26) and taking the real part, easily obtained by applying Euler's omnipotent formula. Thus,

$$\begin{aligned} i(t) &= I_m \cos(\omega t + \phi) \\ &= \frac{E_m}{\sqrt{R^2 + \omega^2 L^2}} \cos\left(\omega t - \tan^{-1} \frac{\omega L}{R}\right) \end{aligned}$$

which agrees with the response obtained for this same circuit in the previous chapter, Eq. (9-4).

Although we have successfully worked a sinusoidal steady-state problem by applying a complex forcing function and obtaining a complex response, we have not taken advantage of the full power of the complex representation. In order

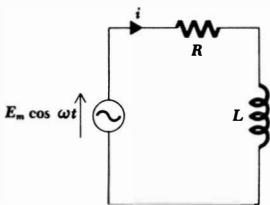

Fig. 10-9 A simple circuit in the sinusoidal steady state is to be analyzed by the application of a complex forcing function.

to do so, we must carry the concept of the complex source or response one additional step and define the quantity called a "phasor."

Drill Problem

10-13 Find the complex current which results when the complex voltage $50e^{j(2t+30^\circ)}$ is applied to: (a) a 10-ohm resistance; (b) a 2-henry inductance; (c) a 0.2-farad capacitance.

Ans. $20e^{j(2t+120^\circ)}$ amp; $12.5e^{j(2t-60^\circ)}$ amp; $5e^{j(2t+30^\circ)}$ amp

10-8 THE PHASOR

A sinusoidal current or voltage *at a given frequency* is characterized by only two parameters, an amplitude and a phase angle. The complex representation of the voltage or current is also characterized by these same two parameters. For example, the assumed sinusoidal form of the current response in the example above was

$$I_m \cos(\omega t + \phi)$$

and the corresponding representation of this current in complex form is

$$I_m e^{j(\omega t + \phi)}$$

Once I_m and ϕ are specified, the current is exactly defined. Throughout any linear circuit operating in the sinusoidal steady state at a single frequency ω , every current and voltage may be characterized completely by a knowledge of its amplitude and phase angle. Moreover, the complex representation of every voltage and current will contain the same factor $e^{j\omega t}$. The factor is superfluous; since it is the same for every quantity, it contains no useful information. Of course, the value of the frequency may be recognized by inspecting one of these factors, but it is a lot simpler to write down the value of the frequency near the circuit diagram once and for all and avoid carrying redundant information throughout the solution. Thus, we could simplify the voltage source and the current response of the example by representing them concisely as

$$E_m \quad \text{or} \quad E_m e^{j0^\circ} \quad \text{and} \quad I_m e^{j\phi}$$

These complex quantities are usually written in polar form rather than exponential form in order to achieve a slight additional saving of time and effort. Thus, the source voltage

$$e(t) = E_m \cos \omega t$$

we now express in complex form as

$$E_m / 0^\circ$$

and the current response

$$i(t) = I_m \cos(\omega t + \phi)$$

becomes

$$I_m/\phi$$

This abbreviated complex representation is called a *phasor*. Let us review the steps by which a real sinusoidal voltage or current is transformed into a phasor, and then we shall be able to define a phasor more meaningfully and to assign a symbol to represent it.

A real sinusoidal current

$$i(t) = I_m \cos(\omega t + \phi)$$

is expressed as the real part of a complex quantity by Euler's identity

$$i(t) = \text{Re}(I_m e^{j(\omega t + \phi)})$$

We then represent the current as a complex quantity by dropping the instruction Re, thus adding an imaginary component to the current without affecting the real component; further simplification is achieved by suppressing the factor $e^{j\omega t}$,

$$\mathbf{I} = I_m e^{j\phi}$$

and writing the result in polar form,

$$\mathbf{I} = I_m/\phi$$

This abbreviated complex representation is the *phasor representation*; phasors are complex quantities and hence are printed in boldface type. Capital letters are used for the phasor representation of an electrical quantity because it is no longer an instantaneous function of time; the phasor contains only amplitude and phase information. We recognize this difference in viewpoint by referring to $i(t)$ as a *time-domain representation* and terming the phasor \mathbf{I} a *frequency-domain representation*. It should be noted that the frequency-domain expression of a current or voltage does not explicitly include the frequency; however, we might think of the frequency as being so fundamental in the frequency domain that it is emphasized by its omission.³

The process by which we change $i(t)$ into \mathbf{I} is called a phasor transformation from the time domain to the frequency domain. The steps in the time-domain to frequency-domain transformation are as follows:

1. Given the sinusoidal function $i(t)$ in the time domain, write $i(t)$ as a cosine wave with a phase angle. For example, $\sin \omega t$ should be written as $\cos(\omega t - 90^\circ)$.
2. Express the cosine wave as the real part of a complex quantity by using Euler's identity.
3. Drop Re.
4. Suppress $e^{j\omega t}$.

As an example, let us transform the time-domain voltage

$$e(t) = 100 \cos(400t - 30^\circ)$$

³ Very little local mail in this country includes "U.S.A." in its address.

into the frequency domain. The time-domain expression is already in the form of a cosine wave with a phase angle, and thus we need take only the real part of the complex representation,

$$e(t) = \text{Re} (100e^{j(400t-30^\circ)})$$

and drop Re and suppress $e^{j\omega t}$,

$$\mathbf{E} = 100 \angle -30^\circ$$

In a similar fashion, the time-domain current

$$i(t) = 5 \sin (377t + 150^\circ)$$

transforms into the phasor

$$\mathbf{I} = 5 \angle 60^\circ$$

Before we consider the analysis of circuits in the sinusoidal steady state through the use of phasors, it is necessary to learn how to shift our transformation smoothly into reverse to return to the time domain from the frequency domain. The process is exactly the reverse of the time-domain to frequency-domain transformation; the same steps are taken, but in the opposite order. Thus, the steps in the frequency-domain to time-domain transformation are as follows:

1. Given the phasor current \mathbf{I} in the frequency domain, write the complex expression in exponential form.
2. Reinsert (multiply by) the factor $e^{j\omega t}$.
3. Replace the real-part operator Re.
4. Obtain the time-domain representation by applying Euler's identity. The resultant cosine-wave expression may be changed to a sine wave, if desired, by increasing the argument by 90°

Thus, given the phasor voltage

$$\mathbf{E} = 115 \angle -45^\circ$$

we change from polar to exponential form,

$$\mathbf{E} = 115e^{-j45^\circ}$$

pass from the frequency domain to the time domain by reinserting $e^{j\omega t}$ and the real-part operator,

$$e(t) = \text{Re} (115e^{j(\omega t-45^\circ)})$$

and finally invoke Euler's identity,

$$e(t) = 115 \cos (\omega t - 45^\circ)$$

As a sinusoid, the answer could be written

$$e(t) = 115 \sin (\omega t + 45^\circ)$$

We have been tracing the transformation process by a fairly detailed sequence of steps, but with a little practice it will soon be possible to make the transformation in either direction in a single step. Even after we have achieved this facility, however, it will be well to know the exact steps and the mathematical justification for each one.

Before considering the methods of applying phasors in the analysis of the sinusoidal steady-state circuit, we may treat ourselves to a quick preview by returning to the example of the RL series circuit. A number of steps after writing the applicable differential equation, we arrived at Eq. (10-25), rewritten below,

$$RI_m e^{j\phi} + j\omega LI_m e^{j\phi} = E_m$$

If we substitute phasors for the current,

$$\mathbf{I} = I_m \angle \phi$$

and the voltage

$$\mathbf{E} = E_m \angle 0^\circ$$

we obtain

$$R\mathbf{I} + j\omega L\mathbf{I} = \mathbf{E}$$

$$\text{or} \quad (R + j\omega L)\mathbf{I} = \mathbf{E} \quad (10-27)$$

a complex algebraic equation in which the current and voltage are expressed in phasor form. This equation is only slightly more complicated than Ohm's law for a single resistor. The next time we analyze this circuit, we shall begin with Eq. (10-27).

Drill Problems

10-14 Express each voltage in phasor form: (a) $30 \cos(120t - 60^\circ)$ volts; (b) $-20 \sin(120t + 40^\circ)$ volts; (c) $15 \sin 120t + 10 \cos(120t + 30^\circ)$ volts.

Ans. $15 - j26$ volts; $8.66 - j10$ volts; $-12.86 + j15.31$ volts

10-15 Transform the following currents to the frequency domain: (a) $3 \sin(100t - 18^\circ)$ amp; (b) $-5 \cos(100t + 90^\circ)$ amp; (c) $3 \cos 100t + 4 \sin 100t$ amp.

Ans. $-j5$ amp; $-0.926 - j2.85$ amp; $3 - j4$ amp

10-16 Transform the voltages below to the time domain: (a) $50 \angle 30^\circ$ volts; (b) $-j50$ volts; (c) $-30 + j40$ volts.

Ans. $50 \cos(\omega t + 126.9^\circ)$ volts; $50 \cos(\omega t - 90^\circ)$ volts; $50 \cos(\omega t + 30^\circ)$ volts

Fig. 10-10 (a) A resistance R at which a time-domain voltage $e(t)$ and a time-domain current $i(t)$ are present. (b) A resistance R at which a frequency-domain voltage \mathbf{E} and a frequency-domain current \mathbf{I} are present.

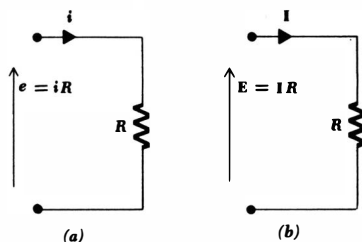

10-17 Express these currents as instantaneous functions of time if $\omega = 10^6$: (a) $0.12 - j0.05$ amp; (b) $0.13/\underline{900^\circ}$ amp; (c) $0.08/\underline{45^\circ} + 0.06044$ amp.

Ans. $0.13 \cos(10^6t - 22.6^\circ)$ amp; $-0.13 \cos 10^6t$ amp; $0.13 \cos(10^6t + 25.8^\circ)$ amp.

10-9 PHASOR RELATIONSHIPS FOR $R, L,$ AND C

Now that we are able to transform into and out of the frequency domain, we can proceed to our simplification of sinusoidal steady-state analysis by establishing the relationship between the phasor voltage and phasor current for each of the three passive elements. We shall begin with the defining equation for each of the elements, a time-domain relationship. We shall then let both the current and the voltage become complex quantities. After suppressing $e^{j\omega t}$ throughout the equation, the desired relationship between the phasor voltage and phasor current will then become apparent.

The resistor provides the simplest case. In the time domain, as indicated by Fig. 10-10a, the defining equation is

$$e(t) = Ri(t) \quad (10-28)$$

Now let us apply the complex voltage

$$E_m e^{j(\omega t + \theta)} = E_m \cos(\omega t + \theta) + jE_m \sin(\omega t + \theta) \quad (10-29)$$

and assume the complex current

$$I_m e^{j(\omega t + \phi)} = I_m \cos(\omega t + \phi) + jI_m \sin(\omega t + \phi) \quad (10-30)$$

and obtain

$$E_m e^{j(\omega t + \theta)} = RI_m e^{j(\omega t + \phi)}$$

By dividing throughout by $e^{j\omega t}$ (or suppressing $e^{j\omega t}$ on both sides of the equation), we find

$$E_m e^{j\theta} = RI_m e^{j\phi}$$

or, in polar form,

$$E_m/\underline{\theta} = RI_m/\underline{\phi}$$

301 The Phasor Concept

But E_m/θ and I_m/ϕ merely represent the general voltage and current phasors \mathbf{E} and \mathbf{I} . Thus,

$$\mathbf{E} = \mathbf{I}R \tag{10-31}$$

The voltage-current relationship in phasor form for a resistance has the same form as the relationship between the time-domain voltage and current. The defining equation in phasor form is illustrated in Fig. 10-10*b*. The equality of the angles θ and ϕ is apparent, and the current and voltage are thus in phase.

As an example of the use of both the time-domain and frequency-domain relationships, let us assume a voltage of $8 \cos(100t - 50^\circ)$ volts across a 4-ohm resistor. Working in the time domain, we find that the current must be

$$i(t) = \frac{e(t)}{R} = 2 \cos(100t - 50^\circ)$$

The phasor form of the same voltage is $8\angle-50^\circ$ volts, and therefore

$$\mathbf{I} = \frac{\mathbf{E}}{R} = 2\angle-50^\circ$$

If we transform this answer back to the time domain, it is evident that the same expression for the current is obtained.

It is apparent that there is no saving in time or effort when a resistive circuit is analyzed in the frequency domain. As a matter of fact, if it is necessary to transform a given time-domain source to the frequency domain and then translate the desired response back to the time domain, we should be much better off working completely in the time domain. This definitely does not apply to any circuit containing resistance and either inductance or capacitance.

Let us now turn to the inductor. The time-domain network is shown in Fig. 10-11*a*, and the defining equation, a time-domain expression, is

$$e(t) = L \frac{di(t)}{dt} \tag{10-32}$$

After substituting the complex voltage equation (10-29) and complex current equation (10-30) into Eq. (10-32), we have

$$E_m e^{j(\omega t + \theta)} = L \frac{d}{dt} \left(I_m e^{j(\omega t + \phi)} \right)$$

Fig. 10-11 (a) The relationship between the time-domain voltage $e(t)$ and current $i(t)$ is shown for an inductance L . (b) The relationship between the frequency-domain voltage \mathbf{E} and current \mathbf{I} is shown for an inductance L .

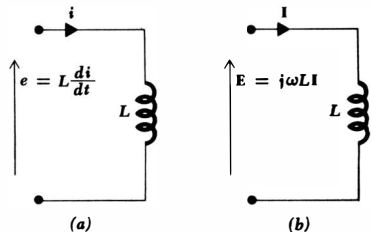

302 Sinusoidal Analysis

Taking the indicated derivative

$$E_m e^{j(\omega t + \theta)} = j\omega L I_m e^{j(\omega t + \phi)}$$

and suppressing $e^{j\omega t}$,

$$E_m e^{j\theta} = j\omega L I_m e^{j\phi}$$

we obtain the desired phasor relationship

$$\mathbf{E} = j\omega L \mathbf{I} \quad (10-33)$$

The time-domain differential equation (10-32) has become an algebraic equation in the frequency domain. The phasor relationship is indicated in Fig. 10-11*b*.

As an illustration of the phasor relationship, let us apply the voltage $8\angle-50^\circ$ volts at a frequency $\omega = 100$ to a 4-henry inductor. From Eq. (10-33), the phasor current is

$$\mathbf{I} = \frac{\mathbf{E}}{j\omega L} = \frac{8\angle-50^\circ}{j100(4)} = -j0.02\angle-50^\circ$$

or $\mathbf{I} = 0.02\angle-140^\circ$

If we express this current in the time domain, it becomes

$$i(t) = 0.02 \cos(100t - 140^\circ)$$

This response is also easily obtained by working entirely in the time domain; it is not so easily obtained if resistance or capacitance is combined with the inductance.

The final element we must consider is the capacitor. The definition of capacitance, a familiar time-domain expression, is

$$i(t) = C \frac{de(t)}{dt} \quad (10-34)$$

The equivalent expression in the frequency domain is obtained once more by letting $e(t)$ and $i(t)$ be the complex quantities of Eqs. (10-29) and (10-30), taking the indicated derivative, suppressing $e^{j\omega t}$, and recognizing the phasors \mathbf{E} and \mathbf{I} . It is

$$\mathbf{I} = j\omega C \mathbf{E} \quad (10-35)$$

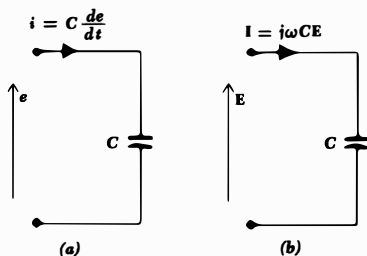

Fig. 10-12 The time-domain (a) and frequency-domain (b) relationship between capacitor voltage and current.

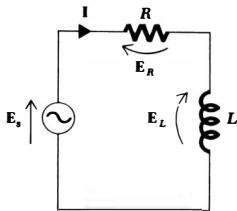

Fig. 10-13 The series RL circuit with a phasor voltage applied.

If the phasor voltage $8\angle-50^\circ$ volts is applied to a 4-farad capacitor at $\omega = 100$, the phasor current is

$$\mathbf{I} = j100(4)(8\angle-50^\circ) = 3200\angle40^\circ \text{ amp}$$

The magnitude of the current is tremendous, but the assumed size of the capacitor is also unrealistic. If a 4-farad capacitor were constructed of two flat plates separated 1 mm in air, each plate would have the area of about 85,000 football fields.⁴ The time-domain and frequency-domain representations are compared in Fig. 10-12*a* and *b*.

We have now obtained the **E-I** relationships for the three passive elements. Each expression is algebraic in nature. Each is also a linear equation, and the equations relating to inductance and capacitance bear a great similarity to Ohm's law. We shall use them as we use Ohm's law.

Before we do so, we must show that phasors satisfy Kirchhoff's two laws. Kirchhoff's voltage law in the time domain is

$$e_1(t) + e_2(t) + \cdots + e_N(t) = 0$$

We now use Euler's identity to replace each real voltage by the complex voltage having the same real part, suppress $e^{j\omega t}$ throughout, and obtain

$$\mathbf{E}_1 + \mathbf{E}_2 + \cdots + \mathbf{E}_N = 0$$

Kirchhoff's current law is shown to hold for phasor currents by a similar argument.

Now let us look briefly at the series *RL* circuit that we have considered several times before. The circuit is shown in Fig. 10-13, and a phasor current and several phasor voltages are indicated. We may obtain the desired response, a time-domain current, by first finding the phasor current. The method is similar to that used in analyzing our first single-loop resistive circuit. From Kirchhoff's voltage law,

$$\mathbf{E}_R + \mathbf{E}_L = \mathbf{E}_s$$

and the recently obtained **E-I** relationships for the elements

$$\mathbf{I}R + j\omega L\mathbf{I} = \mathbf{E}_s$$

⁴ Including both end zones.

304 Sinusoidal Analysis

the phasor current is found in terms of the source voltage \mathbf{E}_s ,

$$\mathbf{I} = \frac{\mathbf{E}_s}{R + j\omega L}$$

Let us select a source-voltage magnitude of E_m and phase angle of 0° ; the latter merely represents the simplest possible choice of a reference. Thus,

$$\mathbf{I} = \frac{E_m/0^\circ}{R + j\omega L}$$

The current may be transformed to the time domain by first writing it in polar form,

$$\mathbf{I} = \frac{E_m}{\sqrt{R^2 + \omega^2 L^2}} \angle -\tan^{-1} \frac{\omega L}{R}$$

and then following the familiar sequence of steps.

We shall consider this circuit once more in the next section after the introduction of the impedance concept.

Drill Problems

10-18 Assuming a passive sign convention, find the phasor current, in rectangular form, which flows when a phasor voltage of $6\angle-36.9^\circ$ volts at $\omega = .1000$ is applied to: (a) a 3-ohm resistor; (b) a 1-mh inductor; (c) a 200- μ f capacitor.

Ans. $1.6 - j1.2$ amp; $-3.6 - j4.8$ amp; $0.72 + j0.96$ amp

10-19 The frequency-domain current flowing through each of the elements below is $2 - j5$ amp at $\omega = 2$. Assuming a passive sign convention, find the frequency-domain voltage across the element: (a) a 0.4-henry inductor; (b) a 0.625-farad capacitor; (c) a 2-ohm resistor.

Ans. $10.78\angle-68.2^\circ$ volts; $4.31\angle-158.2^\circ$ volts; $4.31\angle21.8^\circ$ volts

10-10 IMPEDANCE

The current-voltage relationships for the three passive elements in the frequency domain are

$$\mathbf{E} = \mathbf{I}R \quad \mathbf{E} = j\omega L\mathbf{I} \quad \mathbf{E} = \frac{\mathbf{I}}{j\omega C}$$

If these equations are written as phasor-voltage phasor-current ratios

$$\frac{\mathbf{E}}{\mathbf{I}} = R \quad \frac{\mathbf{E}}{\mathbf{I}} = j\omega L \quad \frac{\mathbf{E}}{\mathbf{I}} = \frac{1}{j\omega C}$$

then we find that these ratios are simple functions of the element values, and frequency also, in the case of inductance and capacitance. Such ratios are func-

305 The Phasor Concept

tions of time in the time domain for inductance and capacitance, and the specific forms of these functions depend on the specific form of the voltage or current. For example, it is easily shown that the time-domain inductor voltage

$$e = E_m \cos(\omega t + \theta)$$

produces a time-domain voltage-current ratio

$$\frac{e(t)}{i(t)} = \omega L \cot(\omega t + \theta)$$

This ratio is not constant for either a given frequency or a given instant of time. The frequency-domain ratios, however, *are constant for a given frequency* and are not functions of time. We treat these ratios in the same manner we treat resistances, with the exception that they are complex quantities and all algebraic manipulations must be those appropriate for complex numbers.

Let us define the ratio of the phasor voltage to the phasor current as *impedance*, symbolized by the letter \mathbf{Z} . The impedance is a complex quantity having the dimensions of ohms. Impedance is not a phasor and cannot be transformed to the time domain by multiplying by $e^{j\omega t}$ and taking the real part. Instead, we think of an inductor L as being represented in the time domain by its inductance L and in the frequency domain by its impedance $j\omega L$. A capacitor in the time domain is a capacitance C and an impedance $1/j\omega C$ in the frequency domain. Impedance is a part of the frequency domain and not a concept which is a part of the time domain.

The validity of Kirchhoff's two laws in the frequency domain enables it to be easily demonstrated that impedances may be combined in series and parallel by the same rules we have already established for resistances. For example, at $\omega = 10$, a 5-henry inductor in series with a 0.1-farad capacitor may be replaced by the single impedance which is the sum of the individual impedances. The impedance of the inductor is

$$\mathbf{Z}_L = j\omega L = j50 \text{ ohms}$$

the impedance of the capacitor is

$$\mathbf{Z}_C = \frac{1}{j\omega C} = -j1 \text{ ohm}$$

and the impedance of the series combination is therefore

$$\mathbf{Z}_{eq} = j50 - j1 = j49 \text{ ohms}$$

The impedance of inductors and capacitors is a function of frequency, and this equivalent impedance is thus applicable only at the single frequency at which it was calculated, $\omega = 10$. At $\omega = 5$, $\mathbf{Z}_{eq} = j23$ ohms.

The parallel combination of these same two elements at $\omega = 10$ yields an impedance which is the product over the sum,

$$\mathbf{Z}_{eq} = \frac{(j50)(-j1)}{j50 - j1} = \frac{50}{j49} = -j1.02 \text{ ohms}$$

At $\omega = 5$, the parallel equivalent is $-j2.17$ ohms.

The complex number or quantity representing impedance may be expressed in either polar or rectangular form. In polar form, an impedance, such as $100\angle-60^\circ$, is described as having an impedance magnitude of 100 ohms and a phase angle of -60° . The same impedance in rectangular form, $50 - j86.6$, is said to have a *resistive component*, or *resistance*, of 50 ohms and a *reactive component*, or *reactance*, of -86.6 ohms. The resistive component is the real part of the impedance, and the reactive component is the imaginary component of the impedance, including sign, but of course excluding the imaginary operator. It is important to note that the resistive component of the impedance is not necessarily equal to the resistance of the resistor which is present in the network. For example, a 20-ohm resistance in series with a 5-henry coil at $\omega = 4$ produces an equivalent impedance $\mathbf{Z} = 20 + j20$ ohms, or in polar form, $28.3\angle45^\circ$ ohms. In this case, the resistive component of the impedance is equal to the resistance of the series resistance because the network is a simple series network. However, if these same two elements are placed in parallel, the equivalent impedance is $20(j20)/(20 + j20)$, or $10 + j10$ ohms. The resistive component of the impedance is now 10 ohms.

No special symbol is assigned for impedance magnitude or phase angle. A general form for an impedance in polar form might be

$$\mathbf{Z} = |\mathbf{Z}|\angle\theta$$

In rectangular form, the resistive component is represented by R and the reactive component by X . Thus,

$$\mathbf{Z} = R + jX$$

Let us now use the impedance concept to analyze an RLC circuit, shown in Fig. 10-14a. The circuit is shown in the time domain, and the time-domain response is required. However, the analysis should be carried out in the frequency domain. We therefore begin by drawing a frequency-domain circuit; the source is transformed to the frequency domain, becoming $40\angle-90^\circ$ volts; the response is transformed to the frequency domain, being represented as \mathbf{I} ; and the impedances of the inductor and capacitor, determined at $\omega = 3$, are $j1$ and $-j2$ ohms, respectively. The frequency-domain circuit is shown in Fig. 10-14b.

Fig. 10-14 (a) An RLC circuit for which the forced response $i(t)$ is desired. (b) The frequency-domain equivalent of the given circuit.

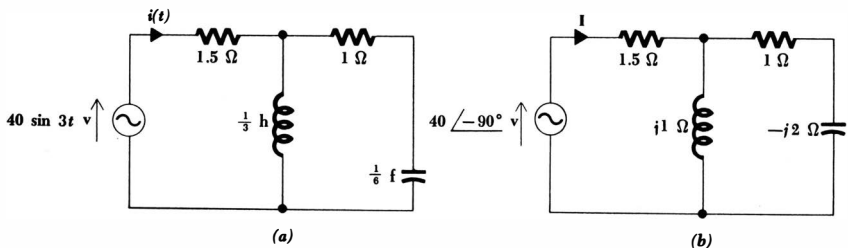

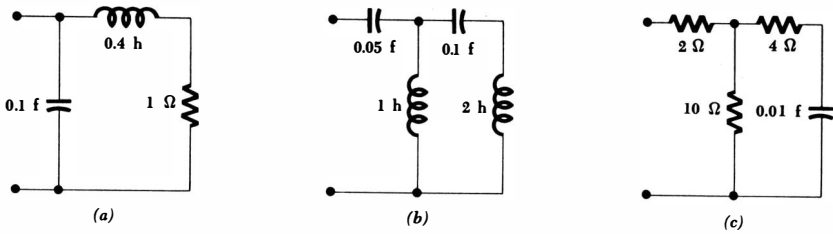

Fig. 10-15 See Drill Probs. 10-20, 10-21, and 10-23.

The equivalent impedance offered to the source is now calculated:

$$\begin{aligned} Z_{eq} &= 1.5 + \frac{(j1)(1-j2)}{j1 + 1-j2} = 1.5 + \frac{2+j1}{1-j1} \\ &= 1.5 + \frac{2+j1}{1-j1} \frac{1+j1}{1+j1} = 1.5 + \frac{1+j3}{2} \\ &= 2 + j1.5 = 2.5/36.9^\circ \end{aligned}$$

The phasor current is thus

$$I = \frac{E_s}{Z_{eq}} = \frac{40/-90^\circ}{2.5/36.9^\circ} = 16/-126.9^\circ$$

Upon transforming the current to the time domain, the desired response is obtained,

$$i(t) = 16 \cos(3t - 126.9^\circ) \quad \text{amp}$$

If the capacitor current is desired, current division should be applied in the frequency domain.

Drill Problems

10-20 Find the input impedance of each of the networks shown in Fig. 10-15a, b, and c at $\omega = 5$.

Ans. $0.924/-90^\circ$ ohms; $10.22/-19.22^\circ$ ohms; $4.47/-26.6^\circ$ ohms

10-21 Find the input voltage across each network of Fig. 10-15a, b, and c if phasor currents at $\omega = 5$ of $1/0^\circ$ amp, $2/90^\circ$ amp, and $0.5/30^\circ$ amp, respectively, are applied.

Ans. $4.47/-26.6^\circ$ volts; $1.848/0^\circ$ volts; $5.11/10.78^\circ$ volts

10-11 ADMITTANCE

Just as conductance, the reciprocal of resistance, proved to be a useful quantity in the analysis of resistive circuits, so does the reciprocal of impedance offer some convenience in the sinusoidal steady-state analysis of a general RLC circuit. We

define *admittance* Y as the ratio of phasor current to phasor voltage:

$$Y = \frac{I}{E}$$

and thus

$$Y = \frac{1}{Z}$$

The real part of the admittance is the *conductance* G , and the imaginary part of the admittance is the *susceptance* B . Thus,

$$Y = G + jB = \frac{1}{Z} = \frac{1}{R + jX} \quad (10-36)$$

Equation (10-36) should be scrutinized carefully; it does *not* state that the real part of the admittance is equal to the reciprocal of the real part of the impedance or that the imaginary part of the admittance is equal to the reciprocal of the imaginary part of the impedance. Admittance, conductance, and susceptance are all measured in mhos.

An impedance

$$Z = 1 - j2 \text{ ohms}$$

which might be represented, for example, by a 1-ohm resistance in series with a suitable capacitance, say 0.1 farad if $\omega = 5$, possesses an admittance

$$\begin{aligned} Y &= \frac{1}{Z} = \frac{1}{1 - j2} = \frac{1}{1 - j2} \frac{1 + j2}{1 + j2} \\ &= 0.2 + j0.4 \text{ mho} \end{aligned}$$

Without stopping to inspect a formal proof, it should be apparent that the equivalent admittance of a network consisting of a number of parallel branches is the sum of the admittances of the individual branches. Thus, the numerical value of the admittance above might be obtained from a conductance of 0.2 mho in parallel with a positive susceptance of 0.4 mho. The former could be represented by a 5-ohm resistor and the latter by a 0.08-farad capacitor at $\omega = 5$, since the admittance of a capacitor is evidently $j\omega C$.

As a check on our analysis, let us compute the impedance of this latest network, a 5-ohm resistor in parallel with a 0.08-farad capacitor at $\omega = 5$. The equivalent impedance is

$$Z = \frac{5(1/j\omega C)}{5 + 1/j\omega C} = \frac{5(-j2.5)}{5 - j2.5} = 1 - j2 \text{ ohms}$$

as before. These two networks represent only two of an infinite number of different networks which possess this same impedance and admittance at this frequency. They do, however, represent the only two two-element networks, and thus might be considered to be the two simplest networks having an impedance of $1 - j2$ ohms and an admittance of $0.2 + j0.4$ mho at $\omega = 5$.

The term *immittance*, a combination of the words “impedance” and “admittance,” is often used as a general term for both impedance and admittance. For example, it is evident that a knowledge of the phasor voltage across a known immittance enables the current through the immittance to be calculated.

Drill Problems

10-22 Find the conductive part of the admittance which corresponds to the impedance: (a) $Z = 2 + j1$ ohms; (b) $Z = 0.1 - j0.1$ ohm; (c) $Z = 1.5/\underline{-30^\circ}$ ohms.

Ans. 5 mhos; 0.4 mho; 0.577 mho

10-23 Find the input admittance of each of the networks shown in Fig. 10-15a, b, and c at $\omega = 10$.

Ans. $0.0589 + j0.765$ mho; $0.113 + j0.0525$ mho; $0 - j0.22$ mho

Problems

- ◆1 Evaluate j^6 , j^{25} , and j^{1000} .
- ◆2 When a complex number is plotted as a point in the complex plane and a line is drawn connecting that point to the origin, the length A of this line and the angle θ measured in a counterclockwise direction from the positive real axis to this line also serve to locate the point. (a) Find A and θ for the complex numbers: $2 + j5$, $-3 - j2$, $100 - j15$. (b) Find the real and imaginary parts of the complex numbers defined by: $A = 10$, $\theta = 135^\circ$; $A = 0.1$, $\theta = -60^\circ$; $A = 5$, $\theta = 500^\circ$.
- 3 Using an accurate sketch, add the complex numbers $3 - j2$ and $-1 + j7$ graphically and express the result in rectangular form. Check by analytical methods.
- 4 Three complex numbers **A**, **B**, and **C** are shown in the complex plane of Fig. 10-16. Indicate the location of **A***, **B***, and **C***.
- 5 Prove the following statements: (a) The sum of a complex number and its conjugate is a real number. (b) The difference of a complex number and its conjugate is an imaginary number. (c) The product of a complex number and its conjugate is a real number. (d) $AB^* = (A^*B)^*$.

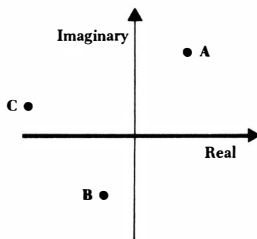

Fig. 10-16 See Prob. 4.

310 Sinusoidal Analysis

- ◆6 Evaluate the following: (a) $(-6 + j2)/(1 - j2)$; (b) $(1 + j1)^4$; (c) $1/(3 + j4) + 1/(3 - j4)$; (d) $(1 + j1)(1 + j2)(1 + j3)$.
 7 Find A if: (a) $A + 10/A = -2$; (b) $AA^* = 100$ and $A + A^* = 12$; (c) $A^3 - A^2 + A = 1$.
 ◆8 If the hyperbolic sine and cosine are defined as follows:

$$\sinh x = \frac{1}{2}(\epsilon^x - \epsilon^{-x}) \quad \cosh x = \frac{1}{2}(\epsilon^x + \epsilon^{-x})$$

use Euler's identity to show that:

$$(a) \sin jx = j \sinh x \quad (b) \cos jx = \cosh x$$

- 9 From a knowledge of the infinite power-series (or Taylor series) expansions for ϵ^x , $\cos x$, and $\sin x$:

$$\epsilon^x = 1 + \frac{x}{1!} + \frac{x^2}{2!} + \frac{x^3}{3!} + \dots$$

$$\cos x = 1 - \frac{x^2}{2!} + \frac{x^4}{4!} - \frac{x^6}{6!} + \dots$$

$$\sin x = x - \frac{x^3}{3!} + \frac{x^5}{5!} - \frac{x^7}{7!} + \dots$$

it may be shown directly that Euler's identity is true. Do so.

- 10 Evaluate: ◆(a) $\epsilon^{j0.1}$; (b) $\epsilon^{-j0.1}$; (c) $\epsilon^{0.2-j0.2}$; (d) $\epsilon^{(1-j1)(0.1-j0.2)}$.
 11 Evaluate: ◆(a) $\cos(0.6 + j0.8)$; (b) $\sin(1 - j1)$; (c) $\tan(1 + j1)$.
 12 Express the following complex numbers in exponential form: (a) ϵ^{1+j2} ; ◆(b) $1 + j5$; (c) $8 - j2$; (d) $-2 + j10$; (e) $-3 - j4$.
 13 Express these complex numbers in rectangular form: ◆(a) $80\epsilon^{j35^\circ}$; (b) $-12\epsilon^{-j60^\circ}$; (c) $5\epsilon^{-j500^\circ}$; (d) $2 - j3\epsilon^{j80^\circ}$; (e) $(3\epsilon^{j30^\circ})^2$; (f) $2\epsilon^{j2}$.
 ◆14 Given the following complex numbers:

$$\begin{array}{lll} \mathbf{A} = 3 + j2 & \mathbf{B} = 1 - j3 & \mathbf{C} = -2 + j1 \\ \mathbf{D} = 4/\underline{40^\circ} & \mathbf{E} = 2/\underline{200^\circ} & \mathbf{F} = 3/\underline{-50^\circ} \end{array}$$

find the result of each of the operations requested below in both rectangular and polar form: (a) $A + B$; (b) $D + E$; (c) $B - F$; (d) $A + B + C$; (e) EF ; (f) AB ; (g) CD ; (h) D/F ; (i) $(A + C)/B$; (j) $A + A^*$; (k) $A - A^*$; (l) AA^* ; (m) $(AA)^*$; (n) $D + D^*$; (o) $(C - jB)^*/A$.

- 15 Find dI/dt as a function of t and then evaluate for $t = 0$, $\omega = 2$: (a) $I = 10\epsilon^{j\omega t}$; (b) $I = (3 + j4)\epsilon^{j(\omega t - 30^\circ)}$; (c) $I = (2/45^\circ)\epsilon^{j(\omega t + 45^\circ)}$.
 16 Find $\int I dt$ as a function of t and then evaluate for $t = 0$ and $\omega = 2$. The three currents are given in Prob. 15.
 17 Show that the quotient of a complex number and its conjugate has a magnitude of unity.
 ◆18 The sum of a complex number and the reciprocal of its conjugate is $2 + j2$. Find the complex number.
 ◆19 Evaluate in both polar and rectangular form: (a) $(3 + j2)^2$; (b) $(4/\underline{20^\circ})^4$; (c) j^{197} ; (d) $(10/\underline{10^\circ})^{10}$; (e) $(1 + j3)^{-3}$; (f) $\sqrt[3]{1000/\underline{0^\circ}}$; (g) $(16/\underline{60^\circ})^{1/4}$; (h) $\sqrt{5 - j2}$; (i) ϵ^{1+j3} ; (j) $\epsilon^{j0.001}$; (k) $\epsilon^{4.8/\underline{150^\circ}}$.

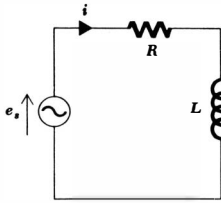

Fig. 10-17 See Probs. 26 and 27.

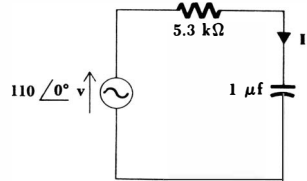

Fig. 10-18 See Prob. 28.

- 20 The logarithm of a complex number is found by expressing the number in exponential form and then using the known relationship for the logarithm of a product. Determine: (a) $\ln(10/90^\circ)$; (b) $\ln(j1)$; (c) $\ln(-5)$; (d) $\ln(3 + j4)$; (e) $\ln(-0.1 + j0.2)$.
- 21 Evaluate: (a) 2^j ; (b) j^j ; (c) $\log_{10}(6 + j8)$; (d) $\frac{e^{2+j(\pi/2)}}{\ln(1 + j1)}$.
- 22 Show that Eq. (10-26) follows from the previous equation.
- 23 It is known that the forced response $i_2(t) = 2 \sin(10^6t - 40^\circ)$ amp results when the forcing function $e_1(t) = 50 \cos 10^6t$ volts is applied to a certain network. Find $i_2(t)$ if this linear network is excited with the forcing function: (a) $50 \sin 10^6t$ volts; (b) $10 \cos(10^6t - 30^\circ)$ volts; (c) $20e^{j10^6t}$ volts; (d) $(3 - j4)e^{j10^6t}$ volts; (e) $50 \cos 10^5t$ volts.
- 24 When an exponential forcing function, say the voltage $e(t) = E_m e^{\sigma t}$, is applied to a linear network, each and every forced current response has the form $i(t) = I_m e^{\sigma t}$. Find the ratio of E_m to I_m , as a function of σ , for: (a) a resistance R ; (b) an inductance L ; (c) a capacitance C .
- 25 The voltage present across a certain element is given below. Find the power being delivered to the element at $t = 0$ if the voltage and the element are, respectively:
- (a) $e = 60 \cos(20t + 45^\circ)$ volts, 12-ohm resistor
 - (b) $E = 100/\underline{0^\circ}$ volts at $\omega = 200$, 5-henry inductor
 - (c) $E = 100/\underline{-90^\circ}$ volts at $\omega = 200$, 5-henry inductor
 - ♦(d) $E = 6/\underline{30^\circ}$ volts at $\omega = 10$, 2-farad capacitor
- 26 The steady-state current is to be found for the circuit shown in Fig. 10-17, where $e_s(t) = 130 \cos 10^4t$ volts, $R = 5$ ohms, $L = 1.2$ mh. (a) Write the forcing function as a phasor E_s . (b) Write the phasor equation which is equivalent to
- $$e_s(t) = Ri(t) + L \frac{di(t)}{dt}$$
- (c) Solve this equation for the phasor current I . (d) Express the current $i(t)$ in the form $i(t) = I_m \cos(\omega t + \theta)$, using numerical values for I_m , ω , and θ .
- 27 Repeat Prob. 26 if $e_s(t) = 15 \cos(400t + 120^\circ)$ volts, $R = 60$ ohms, $L = 0.2$ henry.
- ♦28 Find I and $i(t)$ for the series RC circuit shown in Fig. 10-18 if $f = 60$ cps.

- 29 Find Z , R , and X for each of the two-terminal networks shown in: (a) Fig. 10-19; (b) Fig. 10-20.
 30 If $C_1 = 800 \mu\text{f}$, $C_2 = 1200 \mu\text{f}$, and $\omega = 1000$ in the circuit shown in Fig. 10-21, find I and $i(t)$.

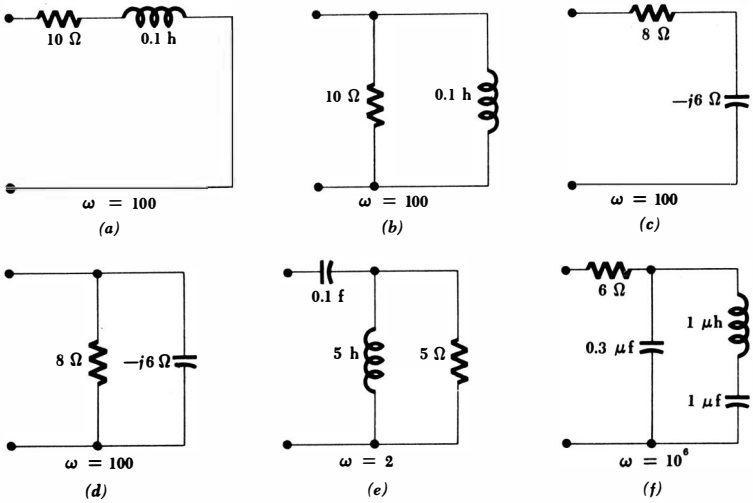
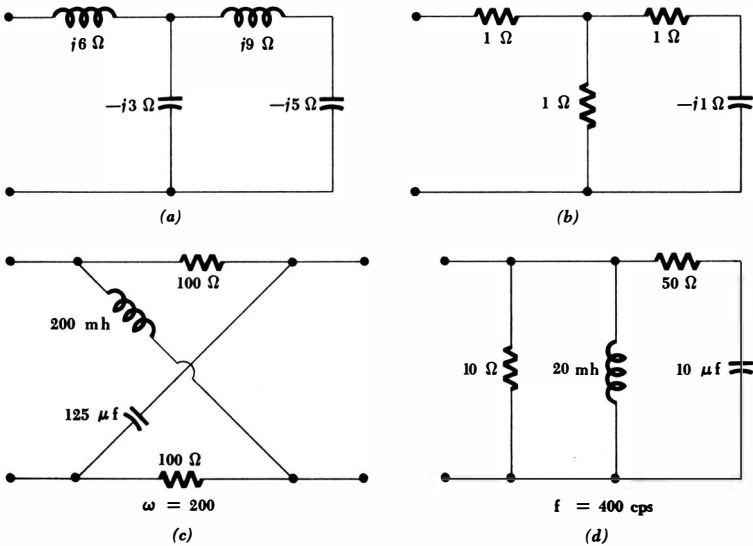

Fig. 10-19 See Prob. 29a.

Fig. 10-20 See Prob. 29b.



313 **The Phasor Concept**

31 Find E and $e(t)$ for the circuit shown in Fig. 10-22 if $\omega = 2 \times 10^6$.

32 Find Y , G , and B for the element combinations shown in Fig. 10-23a, b, c, d, e, and f. Find the resistive and reactive components of the input impedance for the circuits of Fig. 10-23c, d, e, and f.

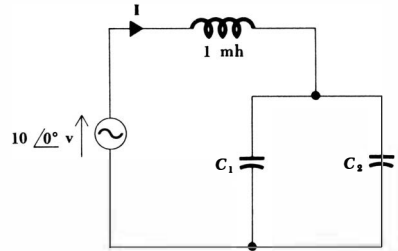

Fig. 10-21 See Prob. 30.

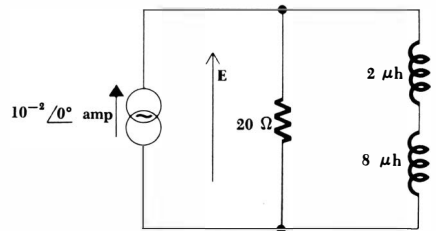
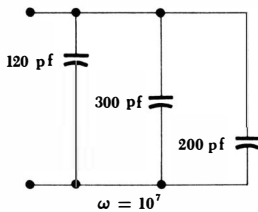
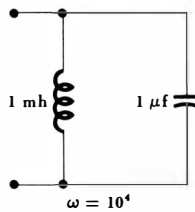

Fig. 10-22 See Prob. 31.

Fig. 10-23 See Prob. 32.



(a)



(b)

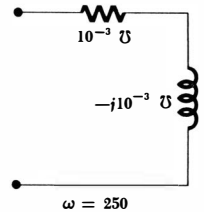

(c)

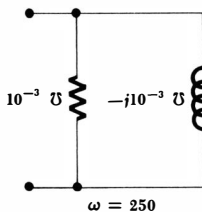

(d)

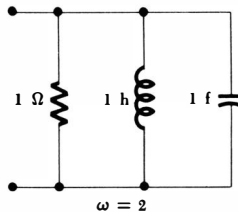

(e)

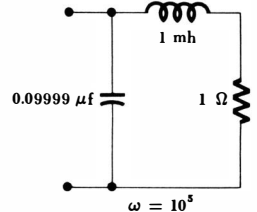

(f)

- 33 Find the input admittance of the network shown in Fig. 10-24.
- ◆34 For the circuit shown in Fig. 10-25, find the value of ω that causes the angle of the input admittance to be 10° .
- 35 Find the input impedance of the circuit shown in Fig. 10-26a.
- 36 Experimental measurements at $\omega = 1000$ show that $i = 20 \sin 1000t$ amp when $e = 107.8 \cos(1000t - 68.2^\circ)$ volts for the circuit shown in Fig. 10-26b. Determine the simplest specific network which might be inside the black box.
- ◆37 Find the input admittance of the circuit shown in Fig. 10-27 as a function of ω .

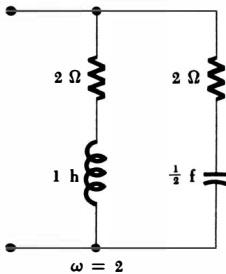

Fig. 10-24 See Prob. 33.

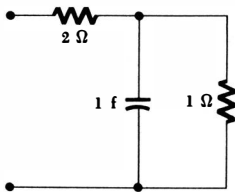
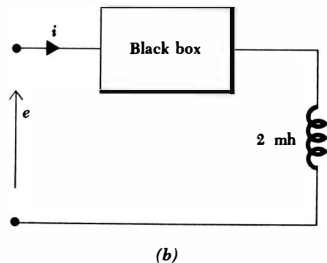
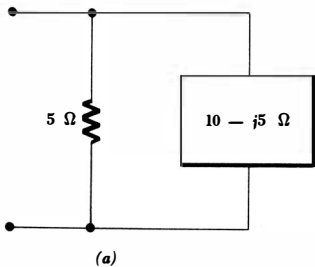

Fig. 10-25 See Prob. 34.

Fig. 10-26 (a) See Prob. 35. (b) See Prob. 36.



315 *The Phasor Concept*

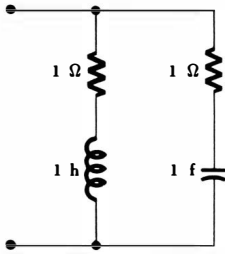

Fig. 10-27 See Prob. 37.

Chapter **11** *The Sinusoidal Steady-state Response*

11-1 INTRODUCTION

In Chap. 2 and, particularly, Chap. 3 we learned a number of methods which are useful in analyzing resistive circuits. No matter what the complexity of the resistive circuit is, we are able to determine any desired response by using mesh or nodal analysis, superposition, source transformations, or Thévenin's or Norton's theorems. Sometimes one method is sufficient, but more often we find it convenient to combine several methods to obtain the response in the most direct manner. We now wish to extend these techniques to the analysis of circuits in the sinusoidal steady state, and we have already seen that impedances combine in the same manner as do resistances. The extension of the techniques of resistive circuit analysis has been promised several times, and we must now find out why the extension is justified and practice its use. We shall begin with mesh analysis.

11-2 MESH AND NODAL ANALYSIS

Let us first consider the arguments by which we accepted mesh analysis for a purely resistive circuit. A general three-mesh circuit is shown in Fig. 11-1, and we shall initially consider the voltage sources to be arbitrary functions of time and the passive circuit elements designated as \mathbf{Z}_1 , \mathbf{Z}_2 , and so forth, to be pure resistances R_1 , R_2 , etc.

After assuming a (clockwise) mesh current in each mesh, as shown in Fig. 11-1, we then identify the voltage across each passive element in the circuit. Such a set of voltages is indicated in Fig. 11-2 for mesh 1 of the general circuit. We next apply Kirchoff's voltage law about each mesh, obtaining for the first mesh

$$-e_{s1} + e_1 + e_{s2} + e_2 + e_3 = 0$$

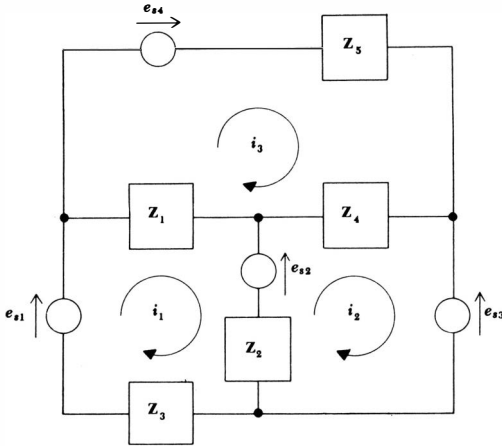

Fig. 11-1 A general three-mesh circuit with assumed clockwise mesh currents.

or, in a more standard form,

$$e_1 + e_2 + e_3 = e_{s1} - e_{s2}$$

Each of the passive elements, assumed for the moment to be resistors, is defined by a voltage-current relationship which demands that the voltage-current ratio be a constant equal to the resistance of the element. Taking care to obey the passive sign convention, we are thus able to replace each term on the left side of the above equation by the product of an appropriate resistance and current,

$$R_1(i_1 - i_3) + R_2(i_1 - i_2) + R_3i_1 = e_{s1} - e_{s2}$$

or, rearranging,

$$(R_1 + R_2 + R_3)i_1 - R_2i_2 - R_1i_3 = e_{s1} - e_{s2}$$

We now employ the shorthand notation for these resistance combinations, letting R_{11} be the sum of all the resistances around mesh 1, R_{12} be the total resistance

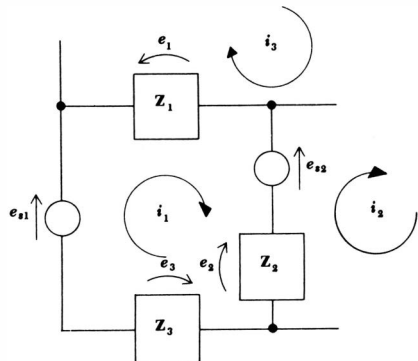
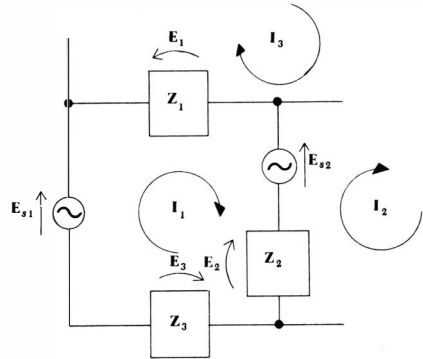

Fig. 11-2 A voltage is assumed across each passive element in the first mesh of the general circuit of Fig. 11-1.

Fig. 11-3 The currents and voltages about mesh 1 of Fig. 11-1 are assumed to be sinusoidal in nature; each is expressed as a phasor in the frequency domain,



common to meshes 1 and 2, and so forth. The result of applying Kirchhoff's voltage law to the first mesh becomes, therefore,

$$R_{11}i_1 - R_{12}i_2 - R_{13}i_3 = e_{s1} - e_{s2}$$

After repeating this procedure for the remaining meshes, a set of three simultaneous algebraic equations results, the three unknowns being the three mesh currents. The equations may be solved easily by determinants, even in those cases in which the voltage sources are not constants and the equations are, strictly speaking, not algebraic equations.

The important point to be noted here is that a mesh equation is nothing more than a mathematical statement of Kirchhoff's voltage law for a particular mesh. The number of unknowns appearing in the complete set of equations is then reduced by expressing each unknown element voltage by the product of the element current and the voltage-to-current ratio, or resistance, for that particular element.

Now let us consider mesh analysis in terms of phasor currents, phasor voltages, and impedances. In the general three-mesh circuit of Fig. 11-1, we now require all the forcing functions to be sinusoidal forcing functions having the same frequency. The general passive elements may now be combinations of resistance, inductance, and capacitance; each is reduced to an equivalent impedance at the source frequency, in accordance with the methods developed for combining impedances in the preceding chapter. Each source voltage is now expressed as a phasor voltage, and each current response is expressed as a phasor current. These quantities are shown on the part of the circuit containing the first mesh in Fig. 11-3; phasor voltages are also assigned to each of the passive elements.

We found in the previous chapter that Kirchhoff's voltage law holds equally well for phasor voltages, and we therefore write for the first mesh

$$\mathbf{E}_1 + \mathbf{E}_2 + \mathbf{E}_3 = \mathbf{E}_{s1} - \mathbf{E}_{s2}$$

The next step must be the expression of the three passive phasor voltages in terms

319 The Sinusoidal Steady-state Response

of the impedances in the mesh and the appropriate phasor currents. Thus,

$$\mathbf{Z}_1(\mathbf{I}_1 - \mathbf{I}_3) + \mathbf{Z}_2(\mathbf{I}_1 - \mathbf{I}_2) + \mathbf{Z}_3\mathbf{I}_1 = \mathbf{E}_{s1} - \mathbf{E}_{s2}$$

and, collecting,

$$(\mathbf{Z}_1 + \mathbf{Z}_2 + \mathbf{Z}_3)\mathbf{I}_1 - \mathbf{Z}_2\mathbf{I}_2 - \mathbf{Z}_1\mathbf{I}_3 = \mathbf{E}_{s1} - \mathbf{E}_{s2}$$

Once again we may employ the simpler notation and let \mathbf{Z}_{11} represent the sum of the impedances around mesh 1, \mathbf{Z}_{12} be the total impedance which is common to meshes 1 and 2, \mathbf{Z}_{13} be the total impedance which is common to meshes 1 and 3, and so forth. We now have a form which looks familiar,

$$\mathbf{Z}_{11}\mathbf{I}_1 - \mathbf{Z}_{12}\mathbf{I}_2 - \mathbf{Z}_{13}\mathbf{I}_3 = \mathbf{E}_{s1} - \mathbf{E}_{s2}$$

where the phasor voltage on the right side is the sum of the phasor source voltages in the counterclockwise sense about the mesh. The mesh equations for the two remaining meshes are obtained by a similar process,

$$-\mathbf{Z}_{21}\mathbf{I}_1 + \mathbf{Z}_{22}\mathbf{I}_2 - \mathbf{Z}_{23}\mathbf{I}_3 = \mathbf{E}_{s2} - \mathbf{E}_{s3}$$

$$-\mathbf{Z}_{31}\mathbf{I}_1 - \mathbf{Z}_{32}\mathbf{I}_2 + \mathbf{Z}_{33}\mathbf{I}_3 = \mathbf{E}_{s4}$$

The set of three equations that we now have is exactly analogous to that which we previously obtained for the resistive network. The differences are obvious: the source voltages are phasors, the mesh currents are phasors, and the complex coefficients are the self- and mutual impedances. The response of the resistive network, however, as represented by the three mesh currents, is the complete response. The response of the *RLC* network is only the forced response, and the complete response is obtained by transforming the forced response to the time domain and adding the natural response to it. The three complex algebraic equations describing the forced response may be solved by elimination of variables, determinants, or a digital computer.

A completely general demonstration of the applicability of mesh analysis to phasors and impedances in the sinusoidal steady state must be based on a general *N*-mesh network, but we shall not concern ourselves with this general proof; nothing new will arise.

Let us apply mesh analysis to the specific circuit shown in Fig. 11-4. The

Fig. 11-4 A frequency-domain circuit in which mesh current are assumed.

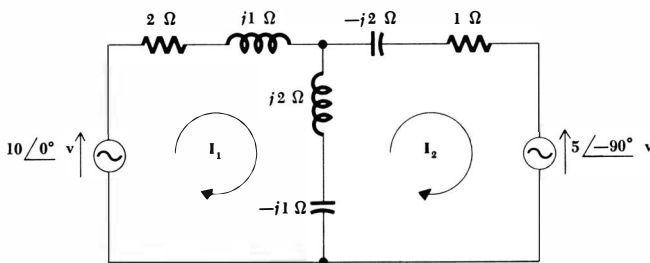

frequency-domain circuit is shown, and we may find the frequency-domain response without any knowledge of the value of the applied frequency. It is, of course, the same for each source. We first write the mesh equation for the left mesh,

$$(2 + j1 + j2 - j1)\mathbf{I}_1 - (j2 - j1)\mathbf{I}_2 = 10$$

and simplify,

$$(2 + j2)\mathbf{I}_1 - j\mathbf{I}_2 = 10 \quad (11-1)$$

then the equation for the right mesh,

$$-(j2 - j1)\mathbf{I}_1 + (1 - j2 + j2 - j1)\mathbf{I}_2 = -(-j5)$$

$$\text{or} \quad -j\mathbf{I}_1 + (1 - j1)\mathbf{I}_2 = j5 \quad (11-2)$$

The use of determinants simplifies the procedure of solving Eqs. (11-1) and (11-2). We have

$$\mathbf{I}_1 = \frac{\begin{vmatrix} 10 & -j1 \\ j5 & 1 - j1 \end{vmatrix}}{\begin{vmatrix} 2 + j2 & -j1 \\ -j1 & 1 - j1 \end{vmatrix}} = \frac{10 - j10 - 5}{2 + 2 + j2 - j2 + 1} = \frac{5 - j10}{5} = 1 - j2$$

and, similarly,

$$\mathbf{I}_2 = \frac{\begin{vmatrix} 2 + j2 & 10 \\ -j1 & j5 \end{vmatrix}}{5} = \frac{j10 - 10 + j10}{5} = -2 + j4$$

The time-domain solutions are therefore obtained by expressing \mathbf{I}_1 and \mathbf{I}_2 in polar form,

$$\mathbf{I}_1 = 2.24 \angle -63.4^\circ \quad \mathbf{I}_2 = 4.47 \angle 116.6^\circ$$

and passing to the time domain,

$$i_1(t) = 2.24 \cos(\omega t - 63.4^\circ) \quad i_2(t) = 4.47 \cos(\omega t + 116.6^\circ)$$

Fig. 11-5 The exact dual of the circuit shown in Fig. 11-4. The voltages \mathbf{E}_1 and \mathbf{E}_2 are to be determined by nodal analysis.

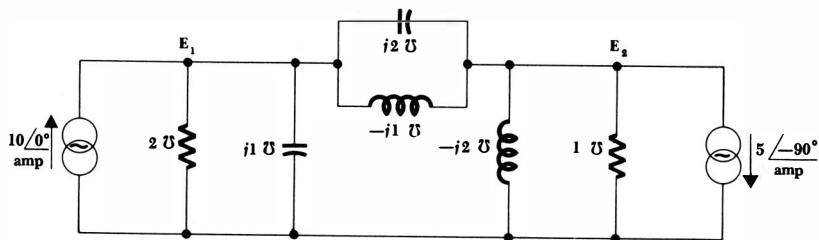

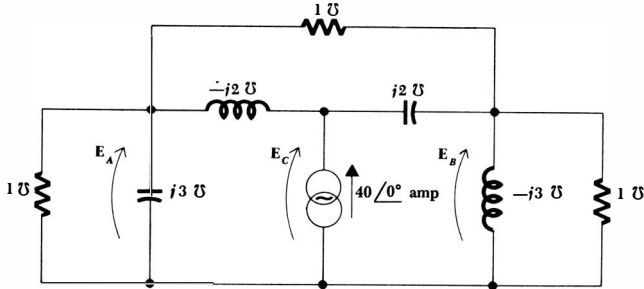

Fig. 11-6 See Drill Prob. 11-1.

The determination of the forced response for this circuit may also be carried out entirely in the time domain, but it would be quite an undertaking and one which is typical of those we may safely ignore because the phasor method is providentially available.

Nodal analysis may also be carried out in the frequency domain in terms of phasors and impedances (or admittances). The arguments by which nodal methods are justified are quite similar to those presented for mesh analysis. Let us construct the dual of the circuit in Fig. 11-4, as shown in Fig. 11-5, and determine the two unknown nodal voltages \mathbf{E}_1 and \mathbf{E}_2 . At the left node, Kirchhoff's current law leads to

$$(2 + j1)\mathbf{E}_1 + (j2 - j1)(\mathbf{E}_1 - \mathbf{E}_2) = 10$$

$$\text{or } (2 + j2)\mathbf{E}_1 - j\mathbf{E}_2 = 10 \quad (11-3)$$

At the right node,

$$(1 - j2)\mathbf{E}_2 + (j2 - j1)(\mathbf{E}_2 - \mathbf{E}_1) = -(-j5)$$

$$\text{or } -j\mathbf{E}_1 + (1 - j1)\mathbf{E}_2 = j5 \quad (11-4)$$

Equations (11-3) and (11-4) are obviously the exact duals of Eqs. (11-1) and (11-2), and their solution must be numerically identical. Thus,

$$\mathbf{E}_1 = 1 - j2 \quad \mathbf{E}_2 = -2 + j4$$

Drill Problems

11-1 Write nodal equations for the circuit shown in Fig. 11-6 and determine: (a) \mathbf{E}_A ; (b) \mathbf{E}_B ; (c) \mathbf{E}_C .

$$\text{Ans. } -10 - j10 \text{ volts; } 20 \text{ volts; } -10 + j10 \text{ volts}$$

11-2 Write mesh equations for the circuit shown in Fig. 11-7 and determine: (a) \mathbf{I}_A ; (b) \mathbf{I}_B ; (c) \mathbf{I}_C .

$$\text{Ans. } -16 + j12 \text{ amp; } 8 - j6 \text{ amp; } -18 + j1 \text{ amp}$$

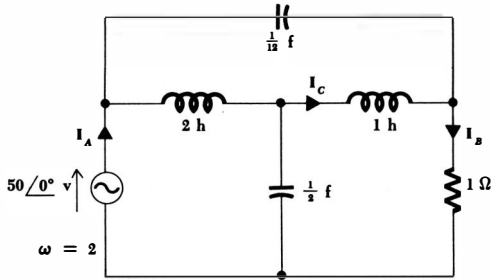

Fig. 11-7 See Drill Prob. 11-2.

11-3 SUPERPOSITION

The superposition principle is another useful analytical method that was initially discussed in the context of resistive circuits. We found then that when the general set of simultaneous algebraic equations describing the circuit was solved for one of the node voltages, the voltage was expressible as the sum of a number of linear terms, each term being a constant function of the resistances in the circuit times one of the current forcing functions. As each source was considered by itself with all other sources replaced by their internal resistances, it was apparent that the total response could be obtained by adding all the responses produced by the sources acting alone.

We next extended the superposition principle in Chap. 4 to apply to the complete response of a general *RLC* circuit with general time-varying excitation. We therefore know that superposition applies to the specific case of the forced response of *RLC* circuits with sinusoidal excitation. The only question that might arise is the applicability of superposition when the forcing functions and responses are expressed in phasor form and the elements are described by their impedances or admittances. However, granted that superposition applies to the time-domain circuit, we see that the response must be the sum of the responses as each source acts alone; each of the single-source circuits may certainly be analyzed by phasor methods. Then if we transform each of these responses back into the time domain, their sum must yield the total steady-state response. May we avoid this extra labor and add the individual frequency-domain responses, taking the time-domain transformation of the total frequency-domain response? It is easily shown that we can, for if we let \mathbf{E}_1 , \mathbf{E}_2 , and so forth, be the phasor representations of $e_1(t)$, $e_2(t)$, etc., then we need show only that

$$e_1(t) + e_2(t) + \cdots + e_N(t) = \text{Re} [(\mathbf{E}_1 + \mathbf{E}_2 + \cdots + \mathbf{E}_N)e^{j\omega t}]$$

This proof is disguised as a problem at the end of this chapter.

The superposition principle should now be included among the analytical methods which are useful for frequency-domain circuits. Let us illustrate its application and simplicity by using it to obtain the response of the circuit of Fig. 11-4 once more. The current \mathbf{I}_1 will be found as the sum of two partial responses, \mathbf{I}_{1L} due to the left source acting alone and \mathbf{I}_{1R} due to the right source

323 The Sinusoidal Steady-state Response

acting alone. Thus,

$$\begin{aligned} \mathbf{I}_{1L} &= \frac{10}{2 + j1 + \frac{(j2 - j1)(-j2 + 1)}{j^2 - j1 - j^2 + 1}} \\ &= \frac{10}{2 + j1 + (2 + j1)/(1 - j1)} \\ &= \frac{10 - j10}{5} = 2 - j2 \end{aligned}$$

while

$$\begin{aligned} \mathbf{I}_{1R} &= - \frac{-j5}{1 - j2 + \frac{(j1)(2 + j1)}{j^2 - j1 + j1 + 2}} \frac{j1}{2 + j1 + j1} \\ &= \frac{-5}{1 - j2 + (-1 + j2)/(2 + j2)} \frac{1}{2 + j2} = -1 \end{aligned}$$

Thus

$$\mathbf{I}_1 = \mathbf{I}_{1L} + \mathbf{I}_{1R} = 1 - j2$$

as before.

Drill Problems

11-3 Find \mathbf{I}_x in each of the circuits of Fig. 11-8*a*, *b*, and *c* by using the superposition principle.

Ans. $7 + j1$ amp; 9 amp; $1 - j3$ amp

11-4 (a) Switch *A* in the circuit shown in Fig. 11-9 has been closed for a long time. Find $i_x(t)$. **(b)** Switch *A* is now opened at $t = 0$. As shown in Chap. 7, Thévenin's theorem enables the charged capacitor to be replaced by an uncharged capacitor in series with an ideal voltage source $100u(t)$ volts, for $t > 0$. Determine $i_x(t)$ for $t > 0$ by superposing the responses produced by each of the two sources acting alone. **(c)** Assume now that switch *A* has been open for a very long time. Determine the instantaneous value of the current that would flow through the switch if it were closed at $t = 0$.

Ans. $-2.5e^{-2.5t} + 4.69 \cos(2t + 51.3^\circ)$ amp; $-2.5 + 7.5 \cos 2t$ amp; infinite amp

11-4 SOURCE TRANSFORMATIONS

It is a simple matter to justify source transformations for sinusoidal steady-state sources when they are expressed as phasors and when the elements in series or parallel with the sources are expressed as impedances. The source transformation is merely a simple application of Thévenin's or Norton's theorems, and we

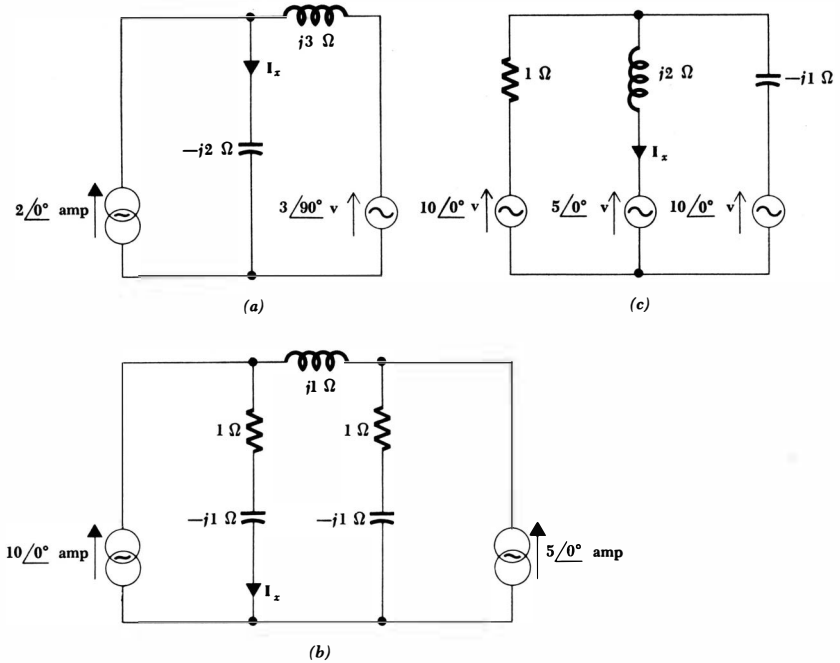
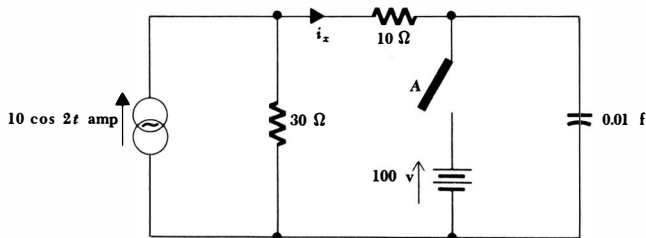

Fig. 11-8 See Drill Probs. 11-3 and 11-5.

could prove its validity by showing that these theorems are valid for phasors and impedances. However, the source transformation is simpler, and its use may be justified without recourse to the two theorems. We shall use the source transformations as a helpful introduction to these theorems.

Let us suppose that we have a circuit which we are to analyze under sinusoidal steady-state conditions. The circuit is drawn in the frequency domain, and we may assume that within it there appears the simple network consisting of a voltage source E_s in series with an impedance Z_s , as illustrated in

Fig. 11-9 See Drill Prob. 11-4.



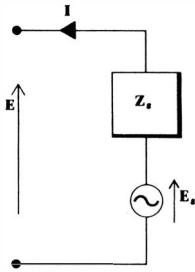

Fig. 11-10 A portion of a frequency-domain circuit to which a source transformation is to be applied.

Fig. 11-10. May we replace this source with a current source I_s , where $I_s = E_s/Z_s$, in parallel with the impedance Z_s ?

Since we know that the entire circuit may be analyzed in the frequency domain through the use of phasors and impedances, in order to demonstrate equivalence we need to show that the terminal E - I characteristics of the two representations are identical. For the voltage source and series impedance shown, the terminal voltage and current phasors are related by

$$E = E_s - IZ_s$$

If we rearrange this relationship,

$$I = \frac{E_s}{Z_s} - \frac{E}{Z_s}$$

then we may identify E_s/Z_s as a current source I_s , and thus

$$I = I_s - \frac{E}{Z_s}$$

This, however, expresses the terminal voltage-current relationship for the current source shown in Fig. 11-11. Thus, the sources of Figs. 11-10 and 11-11 are equivalent if $E_s = I_s Z_s$. It is evident that the transformation may be made in either direction; the analogy with the resistive circuit method is very close.

Drill Problem

11-5 Make repeated source transformations, as necessary, in the circuits shown in Fig. 11-8, until either a single node pair or single mesh

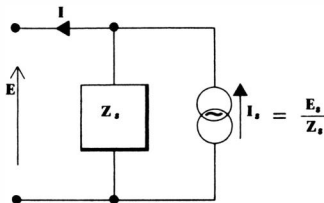

Fig. 11-11 A practical current source which is equivalent to the practical voltage source shown in Fig. 11-10.

circuit is obtained. Do not transform the branch containing \mathbf{I}_x . From the analysis of this simple circuit, determine \mathbf{I}_x for each circuit.

Ans. $7 + j1$ amp; 9 amp; $1 - j3$ amp

11-5 THÉVENIN'S AND NORTON'S THEOREMS

Thévenin's and Norton's theorems have been discussed also in the context of the resistive circuit in Chap. 3 and for the general case in the following chapter. We have been using them often since their introduction, and we should be familiar with their application to any two-terminal linear network, regardless of sources or initial energy storage within the network. It follows, therefore, that they are certainly applicable to the sinusoidal steady state, at least for a time-domain analysis. The extension to the frequency domain follows immediately. We know that an open-circuit voltage or a short-circuit current determined in the frequency domain may be transformed into the time domain where it will be identical with the open-circuit voltage or short-circuit current found through a time-domain analysis. Moreover, the inactive network with which the Thévenin (or Norton) equivalent source is in series (or parallel) may be described interchangeably in the time domain or in the frequency domain. The advantage of the frequency-domain description is a result of the possibility of combining the impedances until a single equivalent impedance is produced.

Let us apply Thévenin's theorem to a frequency-domain network in the sinusoidal steady state. Returning to Fig. 11-4, let us obtain the Thévenin equivalent of the network facing the right-hand source. The open-circuit voltage is found by voltage division,

$$\mathbf{E}_{oc} = 10\angle 0^\circ \frac{j2 - j1}{2 + j1 + j2 - j1} = 2.5 + j2.5$$

and the Thévenin impedance is obtained concisely by series-parallel combinations,

$$\begin{aligned} \mathbf{Z}_{th} &= 1 - j2 + \frac{(2 + j1)(j2 - j1)}{2 + j1 + j2 - j1} \\ &= 1.25 - j1.25 \end{aligned}$$

The response \mathbf{I}_2 is thus

$$\mathbf{I}_2 = \frac{2.5 + j2.5 + j5}{1.25 - j1.25} = -2 + j4$$

as before.

Let us apply Norton's theorem to the same circuit, but with a slightly different problem in mind. If the central LC branch were replaced by a 5-ohm resistor, what current would flow in a downward direction through this resistor? We shall therefore replace everything except this central branch by a Norton equiv-

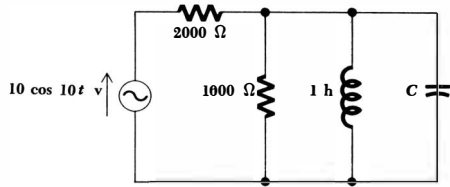

Fig. 11-12 See Drill Probs. 11-6 and 11-7.

alent circuit (or, equally well, the Thévenin equivalent). The short-circuit current is

$$I_{sc} = \frac{10}{2 + j1} + \frac{-j5}{1 - j2} = 6 - j3$$

and the Thévenin impedance becomes

$$Z_{th} = \frac{(2 + j1)(1 - j2)}{2 + j1 + 1 - j2} = 1.5 - j0.5$$

The current through the 5-ohm resistor may be obtained by current division,

$$I = (6 - j3) \frac{1.5 - j0.5}{6.5 - j0.5} = 1.235 - j1.059$$

It is quite evident that the application of Thévenin's and Norton's theorems to the sinusoidal steady state is only slightly more complicated than their application to resistive circuits. Just as with nodal and mesh analysis, source transformations, and the superposition theorem, the slight additional complexity arises from the necessity of using complex numbers and not from any more involved theoretical considerations.

Finally, we should also be pleased to hear that these same techniques will be applicable to the forced response of circuits driven by exponential forcing functions, damped sinusoidal forcing functions, and forcing functions having a *complex frequency* in general. Thus, we shall meet these same techniques again in Chaps. 13 and 14.

Drill Problems

11-6 With reference to Fig. 11-12, first determine the frequency-domain Norton equivalent of the network facing the capacitor C , and then find the magnitude of the capacitor current: (a) if $C = 0.009$ farad; (b) if $C = 0.010$ farad; (c) if $C = 0.011$ farad.

Ans. 44.5 ma; 54.4 ma; 333.3 ma

11-7 Use the Thévenin equivalent of Fig. 11-12 to determine the capacitor voltage magnitude: (a) if $C = 0.009$ farad; (b) if $C = 0.010$ farad; (c) if $C = 0.011$ farad.

Ans. 3.33 volts; 0.495 volt; 0.493 volt

11-6 PHASOR DIAGRAMS

The phasor diagram is a name given to a sketch in the complex plane of the phasor voltages and phasor currents throughout a specific circuit. It provides a graphical method for solving certain problems in which the complex algebraic calculations are tedious; it serves as a check on more exact analytical methods; and it proves to be of considerable help in simplifying the analytical work in certain symmetrical problems by enabling the symmetry to be recognized and helpfully applied. In the following chapter we shall encounter similar diagrams which display the complex power relationships in the sinusoidal steady state. The use of other complex planes will also appear in connection with complex frequency in Chap. 14 and with immittance loci in Chap. 15.

We are already familiar with the use of the complex plane in the graphical identification of a complex number and in their addition and subtraction. Since phasor voltages and currents are complex numbers, they may also be identified as points in a complex plane. For example, the phasor voltage $E_1 = 6 + j8 = 10/\underline{53.1^\circ}$ is identified on the complex voltage plane shown in Fig. 11-13. The axes are the real voltage axis and the imaginary voltage axis; the voltage E_1 is located by an open-headed arrow drawn from the origin. Since addition and subtraction are particularly easy to perform and display on a complex plane, it is apparent that phasors may be easily added and subtracted in a phasor diagram. Multiplication and division result in the addition and subtraction of *angles* and a change of amplitude; the latter is less clearly shown, since the amplitude change depends on the amplitude of each phasor and on the scale of the diagram. Figure 11-14*a* shows the sum of E_1 and a second phasor voltage $E_2 = 3 - j4 = 5/\underline{-53.1^\circ}$, and Fig. 11-14*b* shows the current I_1 , which is the product of E_1 and the admittance $Y = 1 + j1$.

This last phasor diagram shows both current and voltage phasors on the same complex plane; it is understood that each will have its own amplitude scale, but a common angle scale. For example, a phasor voltage 1 in. long might represent 100 volts, while a phasor current 1 in. long could indicate 3 ma. Current phasors are indicated by the use of closed arrowheads and voltage phasors by open arrowheads.

The phasor diagram also offers an interesting interpretation of the time-domain to frequency-domain transformation, since the diagram may be interpreted from either the time- or frequency-domain viewpoint. Up to this time, it is obvious that we have been using the frequency-domain interpretation, be-

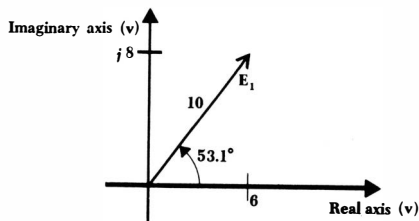

Fig. 11-13 A simple phasor diagram showing the single voltage phasor $E_1 = 6 + j8 = 10/\underline{53.1^\circ}$.

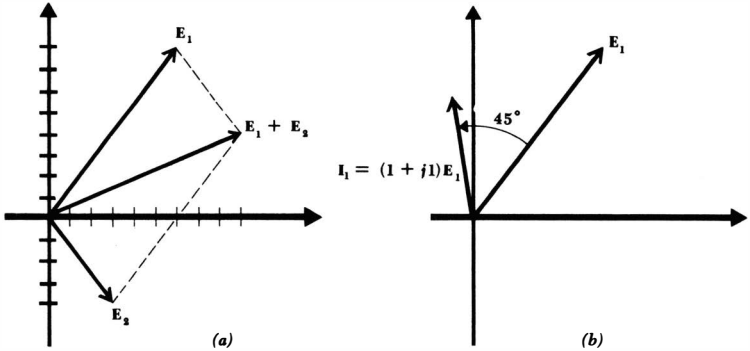
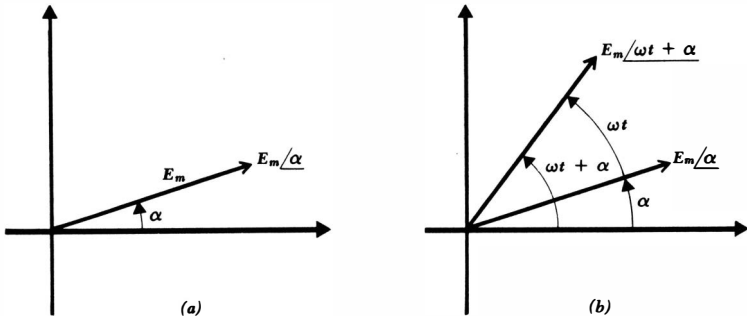

Fig. 11-14 (a) A phasor diagram showing the sum of $E_1 = 6 + j8$ and $E_2 = 3 - j4$, $E_1 + E_2 = 9 + j4 = 9.85/24.0^\circ$. (b) The phasor diagram shows E_1 and I_1 , where $I_1 = YE_1$, and $Y = 1 + j1$ mho.

cause we have been showing phasors directly on the phasor diagram. However, let us proceed to a time-domain viewpoint by first showing the phasor $E = E_m/\alpha$, as sketched in Fig. 11-15a. In order to transform E to the time domain, the next necessary step is the multiplication of the phasor by $e^{j\omega t}$; thus we have the complex voltage $E_m e^{j\omega t} e^{j\alpha} = E_m/\omega t + \alpha$. This voltage may also be interpreted as a phasor, one which possesses a phase angle which increases linearly with time. On a phasor diagram it therefore represents a rotating line segment, the instantaneous position being ωt radians ahead (counterclockwise) of E_m/α . Both E_m/α and $E_m/\omega t + \alpha$ are shown on the phasor diagram of Fig. 11-15b.

The passage to the time domain is now completed by taking the real part of $E_m/\omega t + \alpha$. The real part of this complex quantity, however, is merely the projection of $E_m/\omega t + \alpha$ on the real axis. In summary, then, the frequency-do-

Fig. 11-15 (a) The phasor voltage E_m/α . (b) The complex voltage $E_m/\omega t + \alpha$ is shown as a phasor at a particular instant of time. This phasor leads E_m/α by ωt radians.



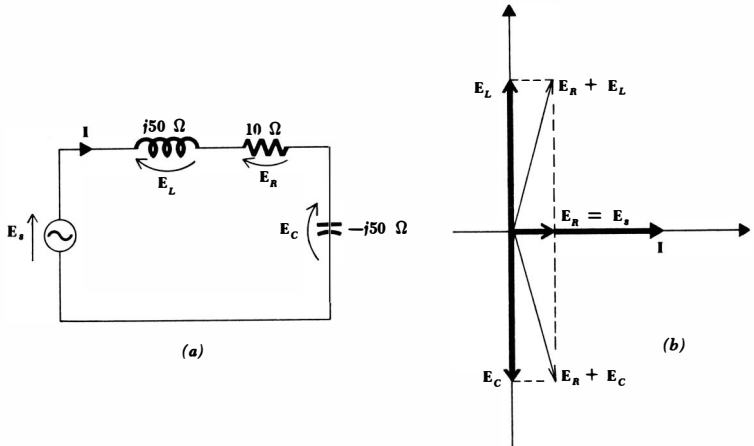

Fig. 11-16 (a) A series RLC circuit shown in the frequency domain. (b) The associated phasor diagram, drawn with the single-mesh current as the reference phasor.

main phasor appears on the phasor diagram, and the transformation to the time domain is accomplished by allowing the phasor to rotate in a counterclockwise direction at an angular velocity of ω radians/sec and then visualizing the projection on the real axis. It is helpful to think of the arrow representing the phasor \mathbf{E} on the phasor diagram as the snapshot, taken at $\omega t = 0$, of a rotating arrow whose projection on the real axis is the instantaneous voltage $e(t)$.

Let us now construct the phasor diagrams for several simple circuits. The series RLC circuit shown in Fig. 11-16a has several different voltages associated with it, but only a single current. The phasor diagram is constructed most easily by employing the single current as the reference phasor. Let us arbitrarily select $\mathbf{I} = I_m/0^\circ$ and place it along the real axis of the phasor diagram, Fig. 11-16b. The resistor, capacitor, and inductor voltages may next be calculated and placed on the diagram, where the 90° phase relationships stand out clearly. The sum of these three voltages is the source voltage, and for this circuit, which is in the resonant condition¹ where $\mathbf{Z}_C = -\mathbf{Z}_L$, the source voltage and resistor voltage are equal. The total voltage across the resistance and inductance or resistance and capacitance is easily obtained from the phasor diagram.

The phasor diagram may be interpreted in the time domain by allowing all the phasors to rotate synchronously with a counterclockwise angular velocity of ω radians/sec, and then considering the projections on the real axis.

Figure 11-17a shows a simple parallel circuit in which it is logical to use the single voltage between the two nodes as a reference phasor. Suppose that $\mathbf{E} = 1/0^\circ$ volt. The resistor current is in phase with this voltage, $\mathbf{I}_R = 0.2/0^\circ$

¹ Resonance will be defined in Chap. 15.

331 The Sinusoidal Steady-state Response

amp, and the capacitor current leads the reference voltage by 90° , $I_C = j0.1$ amp. After these two currents are added to the phasor diagram, shown as Fig. 11-17b, they may be summed to obtain the source current. The result is $I_s = 0.2 + j0.1$ amp.

If the source current were specified initially as, for example, $1/0^\circ$ amp, and the node voltage is not initially known, it is still convenient to begin construction of the phasor diagram by assuming a node voltage, say $E = 1/0^\circ$ volt once again, and using it as the reference phasor. The diagram is then completed as before, and the source current which flows as a result of the assumed node voltage is again found to be $0.2 + j0.1$ amp. The true source current is $1/0^\circ$ amp, however, and thus the true node voltage is greater by the factor $1/0^\circ / (0.2 + j0.1)$; the true node voltage is therefore $4 - j2$ volts. The assumed voltage leads to a phasor diagram which differs from the true phasor diagram by a change of scale (the assumed diagram is smaller by a factor of $1/\sqrt{20}$) and an angular rotation (the assumed diagram is rotated counterclockwise through 26.6°).

Phasor diagrams are usually very simple to construct, and most sinusoidal steady-state analyses will be more meaningful if such a diagram is included. Additional examples of the use of phasor diagrams will appear frequently throughout the remainder of our study.

Drill Problems

11-8 The skeleton outline of a phasor diagram appears in Fig. 11-18. The phasor currents and voltages indicated can be determined with moderate accuracy by use of a scale and protractor. Assume that the diagram applies to a circuit consisting of a capacitance C in parallel with the series combination of a resistance R and an inductance L . A current source I_s is in parallel with the capacitor. Determine the impedance of: (a) the resistor; (b) the inductor; (c) the capacitor.

Ans. $j5.00$ ohms; 2.00 ohms; $-j5.39$ ohms

11-9 The circuit shown in Fig. 11-19 is operated at $\omega = 1000$. Construct a freehand phasor diagram for this circuit without the use of

Fig. 11-17 (a) A parallel RC circuit. (b) The phasor diagram for this circuit; the node voltage is used as a convenient reference phasor.

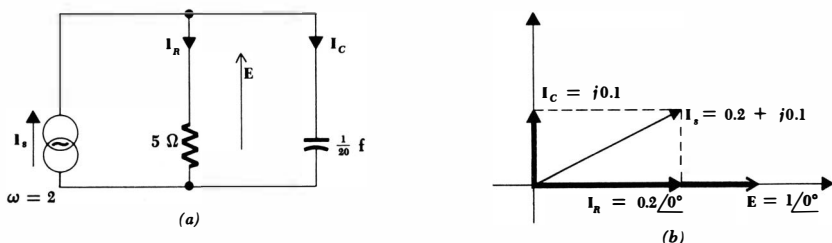

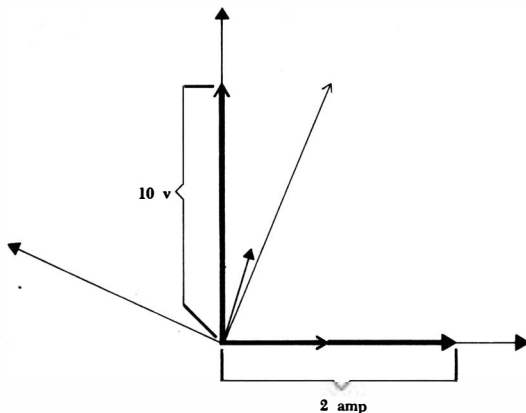

Fig. 11-18 See Drill Prob. 11-8.

scale, protractor, or slide rule. The diagram should be drawn directly after staring at the circuit and performing a few simple mental calculations. Use the diagram to estimate in polar form: (a) I_1 ; (b) I_2 ; (c) I_3 .

Ans. $3/0^\circ$ amp; $6.4/141^\circ$ amp; $4.5/-64^\circ$ amp

Problems

- ◆1 Find I_x and $i_x(t)$ for the circuit shown in Fig. 11-20a.
- 2 Find E_x and $e_x(t)$ for the circuit shown in Fig. 11-20b.
- 3 Find I_x and $i_x(t)$ for the circuit shown in Fig. 11-21a.
- ◆4 Find I_x and $i_x(t)$ for the circuit shown in Fig. 11-21b.
- 5 Find E_x and $e_x(t)$ for the circuit shown in Fig. 11-22a.
- 6 Write a set of mesh equations for the circuit shown in Fig. 11-22b.
- 7 Show that the sum of N time-domain voltages may be obtained by transforming the sum of the corresponding frequency-domain voltages to the time domain. What restrictions must be placed on the time-domain voltages? How does this proof differ from a demonstration that Kirchhoff's voltage law is valid in the frequency domain?
- 8 Solve Prob. 3 with the use of the superposition theorem.

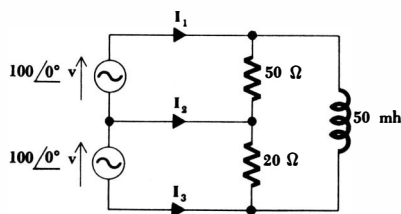

Fig. 11-19 See Drill Prob. 11-9.

333 The Sinusoidal Steady-state Response

- 9 Find $i_1(t)$ for the circuit shown in Fig. 11-23a.
- 10 Find $i_L(t)$ for the circuit shown in Fig. 11-23b.
- 11 Find $e_C(t)$ for $t > 0$ for the circuit shown in Fig. 11-24.
- 12 Find the steady-state current source which is equivalent to an ideal voltage source $60 \cos 5t$ volts in series with a 10-henry inductor.

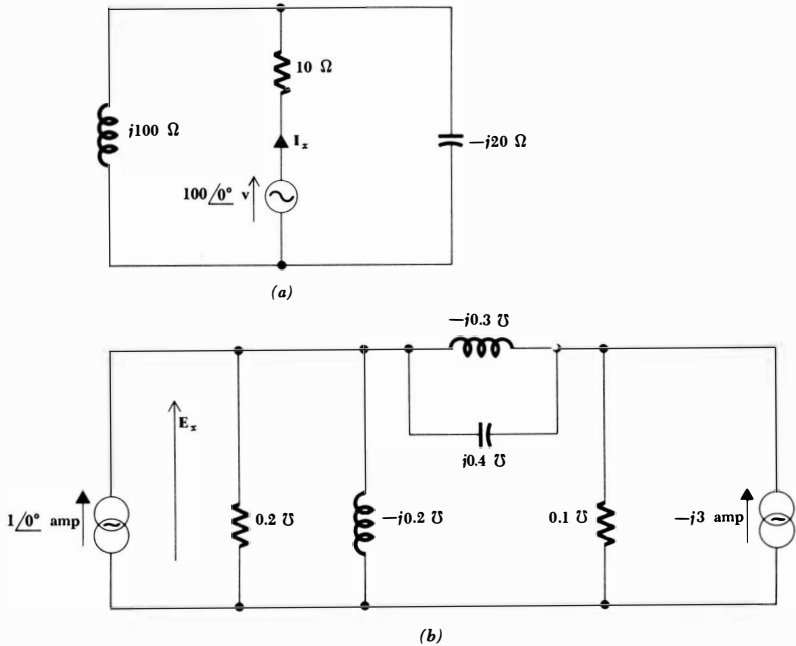
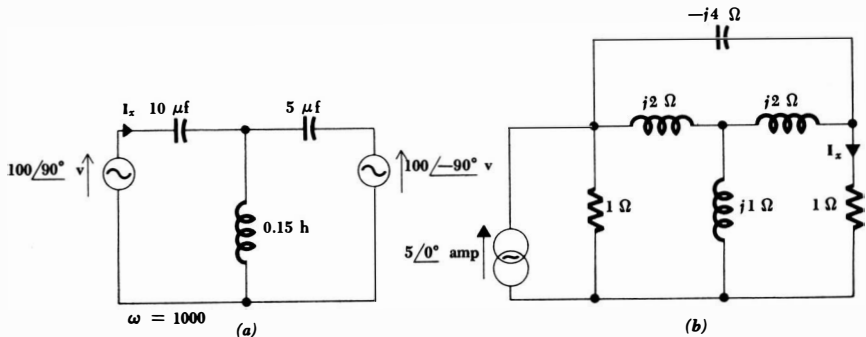

Fig. 11-20 (a) See Prob. 1. (b) See Prob. 2.

Fig. 11-21 (a) See Prob. 3 (b) See Prob. 4.



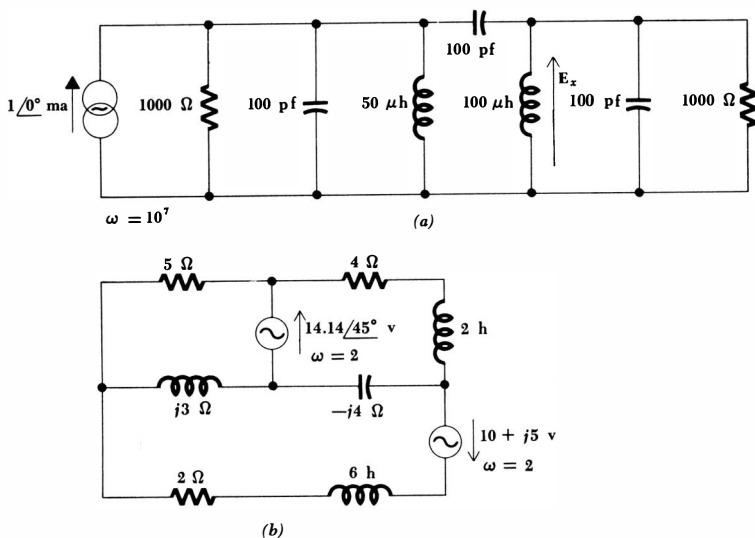

Fig. 11-22 (a) See Prob. 5. (b) See Prob. 6.

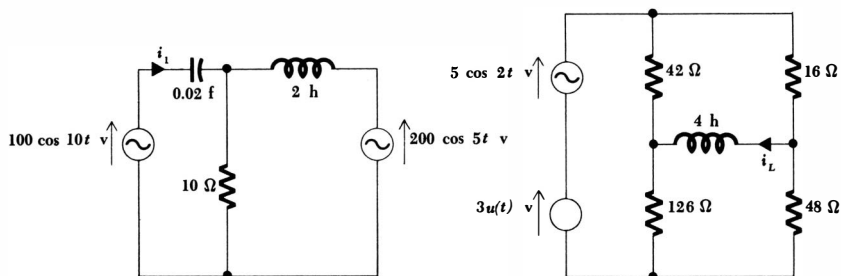

Fig. 11-23 (a) See Prob. 9. (b) See Prob. 10.

- 13 Find both the Thévenin and Norton equivalents of the circuit shown in Fig. 11-25a.
- 14 Find both the Thévenin and Norton equivalents of the circuit shown in Fig. 11-25b.
- ◆15 Two terminals of a network operating at $\omega = 400$ are available for external measurements, as shown in Fig. 11-26a. Two measurements are made: (1) When a $2.5\text{-}\mu\text{f}$ capacitor is placed between the terminals, the voltage across the capacitor is $E_1 = 100$ volts (magnitude). (2) When a 2-henry inductor is placed between the terminals, the voltage across the inductor is $E_2 = 40$ volts (magnitude), and it is determined that E_2 leads E_1 by 90° . Find I_{sc} and the phase angle of I_{sc} with respect to E_1 at 400 radians/sec.

- 16 (a) Find the Thévenin equivalent circuit of the network shown in Fig. 11-26b. (b) Find the Norton equivalent of this same circuit by applying a source transformation to the Thévenin equivalent circuit. (c) Find the Norton equivalent circuit by determining the short-circuit current and Thévenin impedance. (HINT: The difficulty which arises in the determination of the short-circuit current can be circumvented by finding the voltage across either reactive element with the terminals short-circuited.)
- 17 Find the Thévenin and Norton equivalents of the network shown in Fig. 11-27a.

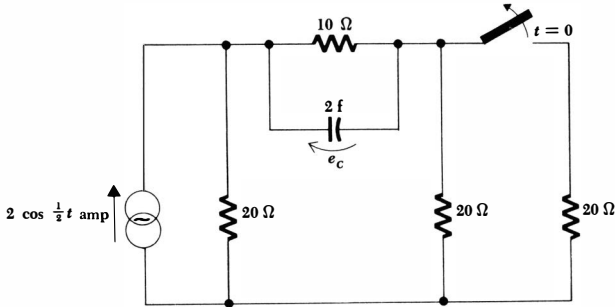

Fig. 11-24 See Prob. 11.

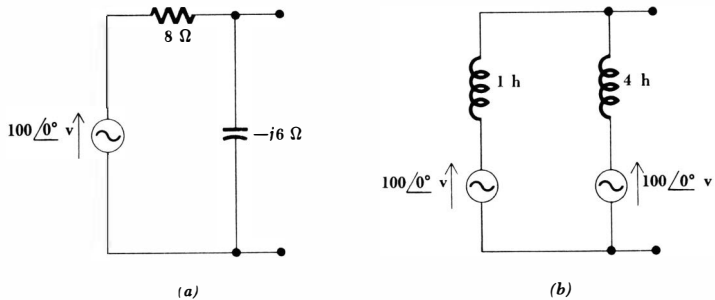
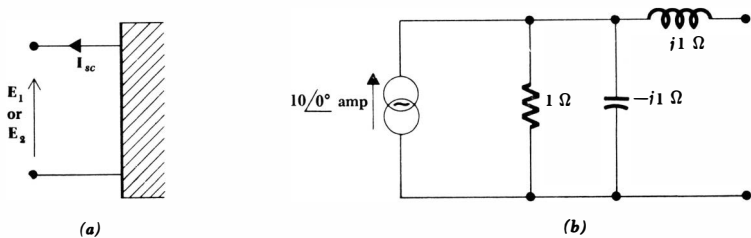

Fig. 11-25 (a) See Prob. 13. (b) See Prob. 14.

Fig. 11-26 (a) See Prob. 15. (b) See Prob. 16.



- ◆18 Use Thévenin's theorem to determine the instantaneous power being delivered to the 12-ohm resistor in the circuit shown in Fig. 11-27*b*.
- 19 Draw an accurate phasor diagram for the circuit shown in Fig. 11-28*a*. Assume that $\mathbf{I} = I_m/0^\circ$, and show \mathbf{E}_R , \mathbf{E}_C , and \mathbf{E}_S . State whether \mathbf{I} leads or lags \mathbf{E}_S and determine the angle graphically. Also determine graphically the ratio of $|\mathbf{E}_C|$ to $|\mathbf{E}_S|$. Verify by another method.
- 20 Repeat Prob. 19 with an assumed current $I = I_m/16^\circ$.
- ◆21 In the circuit outlined in Fig. 11-28*b*, $\mathbf{E}_1 = 2/20^\circ$ volts, $\mathbf{E}_2 = 3/180^\circ$ volts, and $\mathbf{E}_3 = 2/90^\circ$ volts. (a) Find \mathbf{E}_S graphically and check by another method. (b) If $\mathbf{I} = 1/135^\circ$ amp, determine which of the three boxes must contain an active element and what the simplest configuration of passive elements might be in the remaining two boxes if $\omega = 1$.
- 22 In the circuit shown in Fig. 11-28*c*, $\mathbf{E}_S = 120/0^\circ$ volts. (a) Draw a phasor diagram for the circuit showing \mathbf{E}_S , \mathbf{I}_R , \mathbf{I}_L , and \mathbf{I} . (b) Does \mathbf{I} lead or lag \mathbf{E}_S ? (c) Using the phasor diagram, indicate how \mathbf{I} will change if the resistance is halved. (d) How does \mathbf{I} change as the frequency is slowly decreased to zero?
- 23 A sinusoidal voltage source of 120-volt magnitude is connected across the series combination of two unknown impedances \mathbf{Z}_A and \mathbf{Z}_B , as shown in

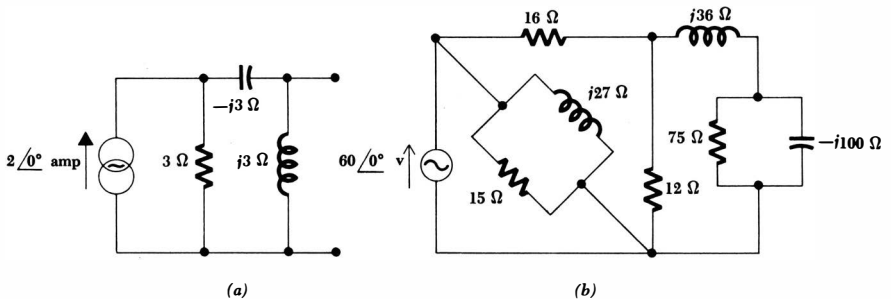
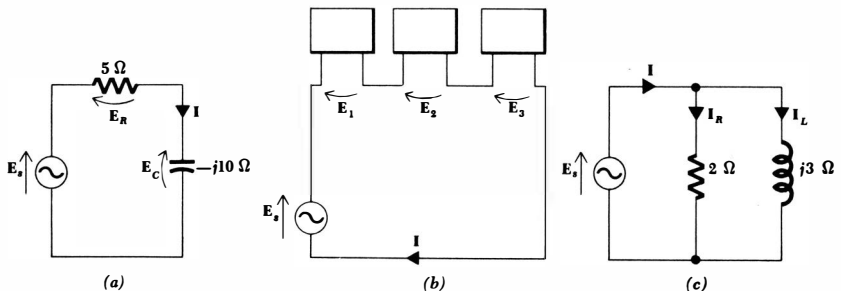

Fig. 11-27 (a) See Prob. 17. (b) See Prob. 18.

Fig. 11-28 (a) See Prob. 19. (b) See Prob. 21. (c) See Prob. 22.



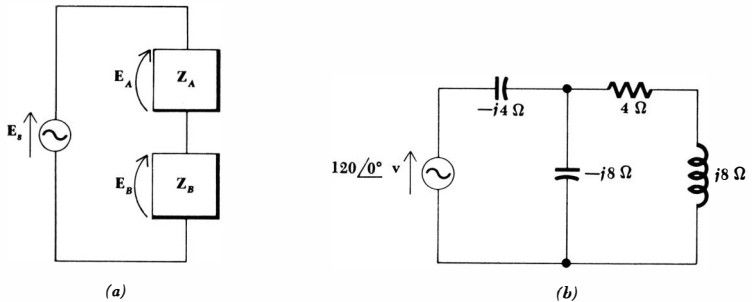

Fig. 11-29 (a) See Prob. 23. (b) See Prob. 24.

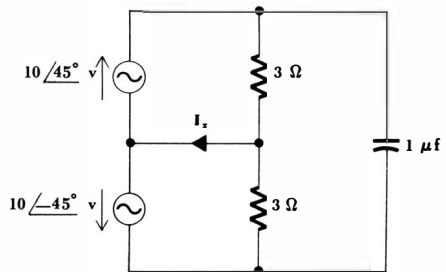

Fig. 11-30 See Prob. 25.

- Fig. 11-29a. The magnitudes of the voltages across Z_A and Z_B are 50 and 100 volts, respectively. (a) Taking the source as the reference phasor, draw the two possible phasor diagrams for this situation and determine the two possible values of E_A and E_B . (b) If Z_A is known to be a single 100-ohm resistor, determine the two possible values of Z_B . If, in addition, Z_B is assumed to be a capacitive impedance, that is, the phase angle of Z_B is less than 0° , draw a simple configuration of elements which will produce Z_B at 1000 cps.
- 24 Determine the phasor voltage and current associated with each element in the circuit of Fig. 11-29b. Draw a complete phasor diagram.
- 25 A circuit possessing obvious symmetry is shown in Fig. 11-30. The presence of the symmetry can simplify the analysis of the circuit if a phasor diagram is drawn. (a) Construct a phasor diagram and find I_x . (b) Find I_x if the upper and lower sources are changed to $10 \angle 52^\circ$ and $10 \angle -52^\circ$ volts, respectively. (c) Find I_x if the upper and lower sources are changed to $10 \angle 75^\circ$ and $10 \angle 25^\circ$ volts, respectively. (d) Repeat part a if the capacitor is doubled in size.
- 26 Draw the phasor diagram of the exact dual of the circuit shown in Fig. 11-16a.

Chapter 12 *Average Power and RMS Values*

12-1 INTRODUCTION

Nearly all problems in circuit analysis are concerned with applying one or more sources of electrical energy to a circuit and then quantitatively determining the consequent response throughout the circuit. The response may be a current or a voltage, but we are also interested in the amount of energy supplied from the sources, in the amount of energy dissipated or stored within the circuit, and in the manner in which energy is delivered to the points at which the responses are determined. Primarily, however, we are concerned with the *rate* at which energy is being generated and absorbed; our attention must now be directed to *power*.

We shall begin by considering instantaneous power, the product of the time-domain voltage and time-domain current associated with the element in which we are interested. The instantaneous power is sometimes quite useful in its own right, because its maximum value might have to be limited in order to avoid exceeding the safe or useful operating range of a physical device. For example, transistor and vacuum-tube power amplifiers both produce a distorted output when the power instantaneously exceeds a certain limiting value. However, we are mainly interested in instantaneous power for the simple reason that it provides us with the means to calculate a more important quantity, the average power. In a similar way, the progress of a cross-country automobile trip is best described by the average velocity; our interest in the instantaneous velocity is limited to the avoidance of maximum velocities which will endanger our safety or arouse the highway patrol.

In practical problems we shall deal with values of average power which range from the small fraction of a picowatt available in a telemetry signal from outer space, the few watts of audio power supplied to the speaker in a high-fidelity system, the several hundred watts required to invigorate the morning coffeepot, to the millions of watts needed to supply all the electrical needs of a large city.

Our discussion will not be concerned entirely with the average power delivered by a sinusoidal current or voltage; we shall establish a mathematical measure of the effectiveness of other waveforms in delivering power, which we shall call the effective value. We shall complete our study of power by considering the descriptive quantities power factor and complex power, two concepts which will introduce the practical and economic aspects associated with the distribution of electric power.

12-2 INSTANTANEOUS POWER

The power delivered to any device as a function of time is given by the product of the instantaneous voltage across the device and the instantaneous current through it, as we well know; the passive sign convention is assumed. Thus,

$$p = ei \quad (12-1)$$

A knowledge of both the current and the voltage is presumed. If the device in question is a resistor R , then the power may be expressed solely in terms of either the current or the voltage,

$$p = ei = i^2R = \frac{e^2}{R} \quad (12-2)$$

If the voltage and current are associated with a device which is entirely inductive, then

$$p = ei = Li \frac{di}{dt} = \frac{1}{L} e \int_{-\infty}^t e dt \quad (12-3)$$

where we have arbitrarily assumed that the voltage is zero at $t = -\infty$. In the case of a capacitor,

$$p = ei = Ce \frac{de}{dt} = \frac{1}{C} i \int_{-\infty}^t i dt \quad (12-4)$$

where a like assumption about the current is made. This listing of equations for power in terms of only a current or voltage soon becomes unwieldy, however, as we begin to consider any more general networks. The listing is also quite unnecessary, for we need only find *both* the current and voltage at the network terminals. As an example, we may consider the series RL circuit, as shown in Fig. 12-1, excited by a step-voltage source. The familiar current response is

$$i(t) = \frac{E_0}{R} (1 - e^{-Rt/L}) u(t)$$

and thus the total power delivered by the source or absorbed by the passive network is

$$p = ei = \frac{E_0^2}{R} (1 - e^{-Rt/L}) u(t)$$

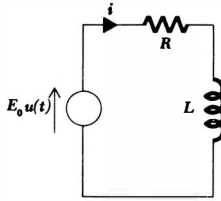

Fig. 12-1 A circuit which is used as an example of the calculation of the instantaneous power relationships throughout a circuit.

since the square of the unit-step function is obviously the unit-step function itself.

The power delivered to the resistor is

$$p_R = i^2 R = \frac{E_0^2}{R} (1 - e^{-Rt/L})^2 u(t)$$

In order to determine the power absorbed by the inductor, we first obtain the inductor voltage

$$\begin{aligned} e_L &= L \frac{di}{dt} \\ &= E_0 e^{-Rt/L} u(t) + \frac{LE_0}{R} (1 - e^{-Rt/L}) \frac{du(t)}{dt} \\ &= E_0 e^{-Rt/L} u(t) \end{aligned}$$

since $du(t)/dt$ is zero for $t > 0$ and $(1 - e^{-Rt/L})$ is zero at $t = 0$. The power absorbed by the inductor is thus

$$p_L = e_L i = \frac{E_0^2}{R} e^{-Rt/L} (1 - e^{-Rt/L}) u(t)$$

Only a few algebraic manipulations are required to show that

$$p = p_R + p_L$$

which serves to check our work.

The majority of the problems which involve power calculations are perhaps those which deal with circuits excited by sinusoidal forcing functions in the steady state; as we have been told previously, even when periodic forcing functions which are not sinusoidal are employed, it is possible to resolve the problem into a number of subproblems in which the forcing functions are sinusoidal. The special case of the sinusoid therefore deserves special attention.

Let us change the voltage source in the circuit of Fig. 12-1 to the sinusoidal source $E_m \cos \omega t$. The familiar time-domain response is

$$i(t) = I_m \cos(\omega t + \theta)$$

where

$$I_m = \frac{E_m}{\sqrt{R^2 + \omega^2 L^2}} \quad \text{and} \quad \theta = -\tan^{-1} \frac{\omega L}{R}$$

341 Average Power and RMS Values

The instantaneous power delivered to the entire circuit in the sinusoidal steady state is, therefore,

$$p = ei = E_m I_m \cos(\omega t + \theta) \cos \omega t$$

which we shall find convenient to rewrite in a form obtained by using the trigonometric identity for the product of two cosine functions. Thus,

$$\begin{aligned} p &= \frac{E_m I_m}{2} [\cos(2\omega t + \theta) + \cos \theta] \\ &= \frac{E_m I_m}{2} \cos \theta + \frac{E_m I_m}{2} \cos(2\omega t + \theta) \end{aligned}$$

The last equation possesses several characteristics which are true in general for circuits in the sinusoidal steady state. One term, the first, is not a function of time; and a second term is included which has a cyclic variation at *twice* the applied frequency. Since this term is a cosine wave, and since sine waves and cosine waves have average values which are zero (when averaged over an integral number of periods), this introductory example may serve to indicate that the *average* power is $\frac{1}{2} E_m I_m \cos \theta$. This is true, and we shall now establish this relationship in more general terms.

Drill Problems

12-1 Assume cosinusoidal excitation in the circuit of Fig. 12-1, with $E_m = 10$ volts, $\omega = 2$, $R = 4$ ohms, and $L = 2$ henrys. Determine the instantaneous value of the power at $t = \pi/4$ sec which is being: (a) delivered by the source; (b) absorbed by the resistor; (c) absorbed by the inductor.

Ans. 6.25 watts; 0 watts; -6.25 watts

12-2 A 1-farad capacitor is charged to 1 volt. At $t = 0$, a 1-henry inductor is suddenly connected in parallel with it. Find the power being absorbed by the inductor at: (a) $t = 0$; (b) $t = \pi/4$; (c) $t = 1638.25\pi$.

Ans. 0 watts; 0.5 watt; 0.5 watt

12-3 AVERAGE POWER

When we speak of an average value for the instantaneous power, the time interval over which the averaging process takes place must be clearly defined. Let us first select a general interval of time from t_1 to t_2 . We may then obtain the average value by integrating $p(t)$ from t_1 to t_2 and dividing the result by the time interval $t_2 - t_1$. Thus,

$$P = \frac{1}{t_2 - t_1} \int_{t_1}^{t_2} p(t) dt \quad (12-5)$$

The average value is denoted by the capital letter P since it is not a function of time, and it usually appears without subscripts. Although P is not a function of time, it is a function of t_1 and t_2 , the two instants of time which define the interval of integration. This dependence of P on a specific time interval may be expressed in a simpler manner if $p(t)$ is a periodic function. We shall consider this important case first.

Let us assume that our forcing function and the circuit responses are all periodic; a steady-state condition has been reached, although not necessarily the sinusoidal steady state. We may define a *periodic* function mathematically by requiring that

$$f(t) = f(t + T) \quad (12-6)$$

where T is the period. We may now show that the average value of the instantaneous power as expressed by Eq. (12-5) may be computed over an interval of one period having an arbitrary beginning.

A general periodic waveform is shown in Fig. 12-2 and identified as $p(t)$. We first compute the average power by integrating from t_1 to a time t_2 which is one period later, $t_2 = t_1 + T$,

$$P_1 = \frac{1}{T} \int_{t_1}^{t_1+T} p(t) dt$$

and then by integrating from some other time t_x to $t_x + T$,

$$P_x = \frac{1}{T} \int_{t_x}^{t_x+T} p(t) dt$$

The equality of P_1 and P_x should be evident from the graphical interpretation of the integrals; the area which represents the integral to be evaluated in determining P_x is smaller by the area from t_1 to t_x , but greater by the area from $t_1 + T$ to $t_x + T$, and the periodic nature of the curve requires these two areas to be equal. Thus, the average power may be computed by integrating the instantaneous power over any interval which is one period in length and then dividing by the period

$$P = \frac{1}{T} \int_{t_x}^{t_x+T} p dt \quad (12-7)$$

It is important to note that we might also integrate over any integral number of periods, provided that we divide by this same integral number of periods. Thus,

$$P = \frac{1}{nT} \int_{t_x}^{t_x+nT} p dt \quad n = 1, 2, 3, \dots \quad (12-8)$$

If we carry this concept to the extreme by integrating over all time, another useful result is obtained. We first provide ourselves with symmetrical limits on the integral

$$P = \frac{1}{nT} \int_{-nT/2}^{nT/2} p dt$$

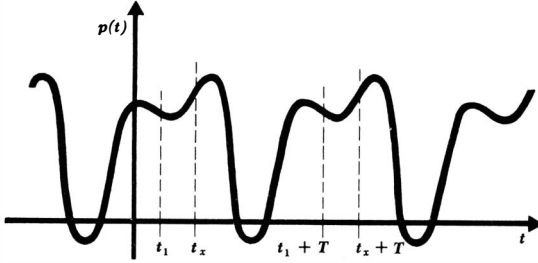

Fig. 12-2 A general periodic power function having a period of T sec.

and then take the limit as n becomes infinite,

$$P = \lim_{n \rightarrow \infty} \frac{1}{nT} \int_{-nT/2}^{nT/2} p \, dt$$

If $p(t)$ is a mathematically well-behaved function, as all *physical* forcing functions and responses are, it is apparent that if a large integer n is replaced by a slightly larger number which is not an integer, then the value of the integral and of P is changed by a negligible amount; moreover, the error decreases as n increases. Without justifying this step rigorously, we therefore replace the discrete variable nT by the continuous variable τ ,

$$P = \lim_{\tau \rightarrow \infty} \frac{1}{\tau} \int_{-\tau/2}^{\tau/2} p \, dt \tag{12-9}$$

We shall find it convenient on several occasions to integrate periodic functions over this “infinite period.” Examples of the use of Eqs. (12-7), (12-8), and (12-9) are given below.

Let us illustrate the calculation of the average power of a periodic wave by finding the average power delivered by the (periodic) sawtooth current waveform shown in Fig. 12-3a to a resistor R . We have

$$i(t) = \frac{I_m}{T} t \quad 0 < t \leq T$$

$$i(t) = \frac{I_m}{T} (t - T) \quad T < t \leq 2T$$

etc.

and
$$p(t) = \frac{1}{T^2} I_m^2 R t^2 \quad 0 < t \leq T$$

$$p(t) = \frac{1}{T^2} I_m^2 R (t - T)^2 \quad T < t \leq 2T$$

etc.

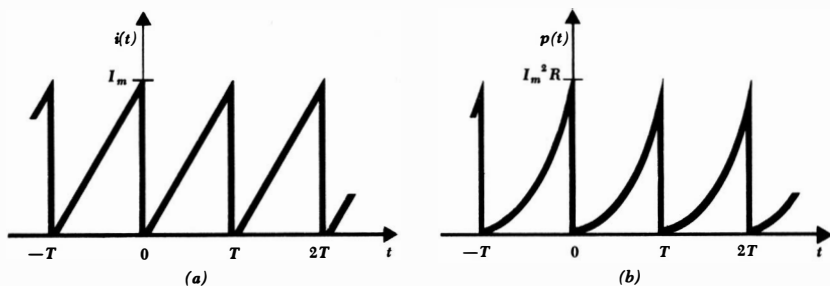

Fig. 12-3 (a) A sawtooth current waveform and (b) the instantaneous power waveform it produces in a resistor R .

as sketched in Fig. 12-3b. Integrating over the simplest range of one period, from $t = 0$ to $t = T$, we have

$$P = \frac{1}{T} \int_0^T \frac{I_m^2 R}{T^2} t^2 dt = \frac{1}{3} I_m^2 R$$

The selection of other ranges of one period, such as from $t = 0.1T$ to $t = 1.1T$, would produce the same answer. Integration from 0 to $2T$ and division by $2T$, that is, the application of Eq. (12-8) with $n = 2$ and $t_x = 0$, would also provide the same answer.

Now let us obtain the general result for the sinusoidal steady state. We shall assume the general sinusoidal voltage

$$e(t) = E_m \cos(\omega t + \alpha)$$

and current

$$i(t) = I_m \cos(\omega t + \alpha - \theta)$$

associated with the device in question. The instantaneous power is

$$p(t) = E_m I_m \cos(\omega t + \alpha) \cos(\omega t + \alpha - \theta)$$

Again expressing the product of two cosine functions as one-half the sum of the cosine of the difference angle and the cosine of the sum angle,

$$p(t) = \frac{1}{2} E_m I_m \cos \theta + \frac{1}{2} E_m I_m \cos(2\omega t + 2\alpha - \theta) \quad (12-10)$$

we may save ourselves some integration by an inspection of the result. The first term is a constant, independent of t . The remaining term is a cosine function; $p(t)$ is therefore periodic, and its period is $\frac{1}{2}T$. Note that the period T is associated with the given current and voltage, and not with the power; the power function has a period $\frac{1}{2}T$. However, we may integrate over an interval of T sec to determine the average value if we wish; it is only necessary to divide also by T sec. Our familiarity with cosine and sine waves, however, shows that the average value of either over a period is zero. There is thus no need to integrate Eq. (12-10) formally; by inspection, the average value of the second term is

345 Average Power and RMS Values

zero over a period T (or $\frac{1}{2}T$), and the average value of the first term, a constant, must be that constant itself. Thus,

$$P = \frac{1}{2}E_m I_m \cos \theta \quad (12-11)$$

This important result, introduced in the previous section for a specific circuit, is therefore quite general. The average power is one-half the product of the crest amplitude of the voltage, the crest amplitude of the current, and the cosine of the phase-angle difference between the current and the voltage; the sense of the difference is immaterial.

As a numerical illustration, let us assume that a voltage

$$e(t) = 4 \cos \frac{\pi t}{6}$$

or $\mathbf{E} = 4\angle 0^\circ$

is applied across an impedance $\mathbf{Z} = 2\angle 60^\circ$ ohms. The phasor current is therefore $2\angle -60^\circ$ amp, and the average power is

$$P = \frac{1}{2}(4)(2) \cos 60^\circ = 2 \text{ watts}$$

The time-domain voltage

$$e(t) = 4 \cos \frac{\pi t}{6}$$

time-domain current

$$i(t) = 2 \cos \left(\frac{\pi t}{6} - 60^\circ \right)$$

and instantaneous power

$$\begin{aligned} p(t) &= 8 \cos \frac{\pi t}{6} \cos \left(\frac{\pi t}{6} - 60^\circ \right) \\ &= 2 + 4 \cos \left(\frac{\pi t}{3} - 60^\circ \right) \end{aligned}$$

are all sketched on the same time axis in Fig. 12-4. Both the 2-watt average value of the power and its period of 6 sec, one-half the period of either the current or the voltage, are evident. The zero value of the instantaneous power at each instant when either the voltage or current is zero is also apparent.

Two special cases are worth isolating for consideration, the average power delivered to an ideal resistor and that to an ideal reactor (any combination of only capacitors and inductors). The phase-angle difference between the current through and the voltage across a pure resistor is zero, and therefore

$$P_R = \frac{1}{2}E_m I_m$$

or $P_R = \frac{1}{2}I_m^2 R \quad (12-12)$

or $P_R = \frac{E_m^2}{2R} \quad (12-13)$

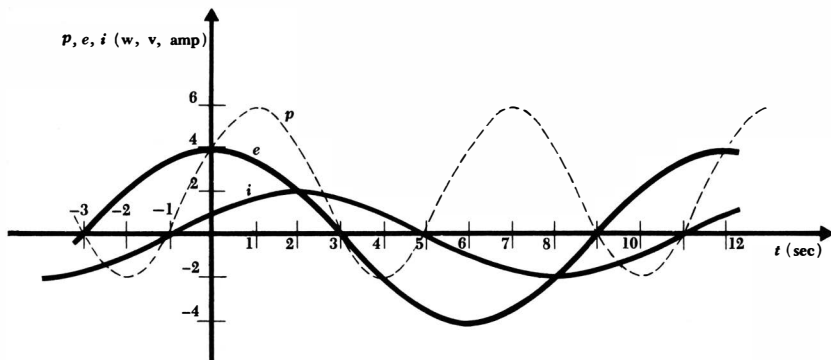

Fig. 12-4 Curves of $e(t)$, $i(t)$, and $p(t)$ are plotted as a function of time for a simple circuit in which the phasor voltage $\mathbf{E} = 4\angle 0^\circ$ volts is applied to the impedance $\mathbf{Z} = 2\angle 60^\circ$ ohms at $\omega = \pi/6$.

The last two formulas, enabling us to determine the average power delivered to a pure resistance from a knowledge of either the sinusoidal current or voltage, are simple and important. They are often misused. The most common error is made in trying to apply them in cases where, say, the voltage included in Eq. (12-13) is *not the voltage across the resistor*. If care is taken to use the current through the resistor in Eq. (12-12) and the voltage across the resistor in Eq. (12-13), satisfactory operation is guaranteed.

The average power delivered to any device which is purely reactive must be zero. This is evident from the 90° phase difference which must exist between current and voltage; hence, $\cos \theta = 0$ and

$$P_x = 0$$

The *average* power delivered to any network composed entirely of ideal inductors and capacitors is zero; the instantaneous power is zero only at specific instants. Thus, power flows into the network for a part of the cycle and out of the network during another portion of the cycle.

As an example illustrating these relationships, let us consider the circuit shown in Fig. 12-5. The values of \mathbf{I}_1 and \mathbf{I}_2 are found by any of several methods, such as mesh analysis or superposition:

$$\mathbf{I}_1 = 5 - j10 = 11.18\angle -63.45^\circ$$

$$\mathbf{I}_2 = 5 - j5 = 7.07\angle -45^\circ$$

The current through the 2-ohm resistor is

$$\mathbf{I}_1 - \mathbf{I}_2 = -j5 = 5\angle -90^\circ$$

and the resistor voltage is, therefore,

$$\mathbf{E}_R = 10\angle -90^\circ$$

347 Average Power and RMS Values

This current and voltage satisfy the passive sign convention, and the average power absorbed by the resistor is, therefore,

$$P_R = \frac{1}{2}(10)(5) \cos(-90^\circ + 90^\circ) = 25 \text{ watts}$$

a result which may be checked by using Eq. (12-12) or (12-13). Turning to the left source, the voltage $20\angle 0^\circ$ and current $11.18\angle -63.45^\circ$ satisfy the *active* sign convention, and thus the power *delivered* by this source is

$$P_{\text{left}} = \frac{1}{2}(20)(11.18) \cos(0^\circ + 63.45^\circ) = 50 \text{ watts}$$

In a similar manner, we find the power *absorbed* by the right source,

$$P_{\text{right}} = \frac{1}{2}(10)(7.07) \cos(0^\circ + 45^\circ) = 25 \text{ watts}$$

The power delivered to each of the two reactive elements is zero; the power relations check.

We must now pay some attention to *nonperiodic* functions. One practical example of a nonperiodic power function for which an average power value is desired is the power output of a radio telescope which is directed toward a "radio star." Another is the sum of a number of periodic functions, each function having a different period, such that no greater common period can be found for the combination. For example, the current

$$i(t) = \sin t + \sin \pi t \tag{12-14}$$

is nonperiodic because the ratio of the periods of the two sine waves is an irrational number. At $t = 0$, both terms are zero and increasing. But the first term is zero and increasing only when $t = 2\pi n$, where n is an integer, and thus periodicity demands that πt or $\pi(2\pi n)$ must equal $2\pi m$, where m is also an integer. No solution (integral values for both m and n) for this equation is possible. It may be illuminating to compare the nonperiodic expression (12-14) with the *periodic* function

$$i(t) = \sin t + \sin 3.14t \tag{12-15}$$

where 3.14 is an exact decimal expression and is not intended to be interpreted as $3.141592 \dots$. With a little effort, it can be shown that the period of this current wave is 100π sec.

The average value of the power delivered to a 1-ohm resistor by either the periodic current (12-15) or the nonperiodic current (12-14) may be found by integrating over an infinite interval; much of the actual integration can be

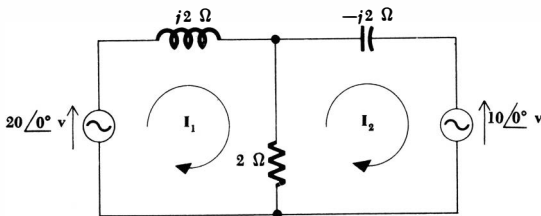

Fig. 12-5 A circuit in the sinusoidal steady state is used to illustrate average power calculations.

avoided because of our thorough knowledge of the average value of simple functions. We therefore obtain the instantaneous power delivered by the current in Eq. (12-14) by applying Eq. (12-9),

$$P = \lim_{\tau \rightarrow \infty} \frac{1}{\tau} \int_{-\tau/2}^{\tau/2} (\sin^2 t + \sin^2 \pi t + 2 \sin t \sin \pi t) dt$$

We now consider P as the sum of three average values. The average value of $\sin^2 t$ over an infinite interval is found by replacing $\sin^2 t$ by $(\frac{1}{2} - \frac{1}{2} \cos 2t)$; it is obviously $\frac{1}{2}$. Similarly, the average value of $\sin^2 \pi t$ is also $\frac{1}{2}$. And the last term can be expressed as the sum of two cosine functions, each of which must certainly have an average value of zero. Thus,

$$P = \frac{1}{2} + \frac{1}{2} = 1 \text{ watt}$$

An identical result is obtained for the periodic current (12-15).

Applying this same method to a current function which is the sum of several sinusoids of *different periods* and arbitrary amplitudes,

$$i(t) = I_{m1} \cos \omega_1 t + I_{m2} \cos \omega_2 t + \cdots + I_{mN} \cos \omega_N t \quad (12-16)$$

we find the average power delivered to a resistance R ,

$$P = \frac{1}{2}(I_{m1}^2 + I_{m2}^2 + \cdots + I_{mN}^2)R \quad (12-17)$$

The result is unchanged if an arbitrary phase angle is assigned to each component of the current. This important result is surprisingly simple when we think of the steps required for its derivation: squaring the current function, integrating, and taking the limit. The result is also just plain surprising, because it shows that, *in this special case of a current such as* (12-16), superposition is applicable to power. Superposition is *not* applicable for a current which is the sum of two direct currents, nor is it applicable for a current which is the sum of two sinusoids of the same period.

Drill Problems

12-3 A sinusoidal voltage $E_s = 100/0^\circ$ volts is applied to each of the networks described below. Find the average power delivered by the source in each case: (a) a 2-ohm resistor in series with a capacitive reactance of 1 ohm; (b) a 4-ohm resistor in parallel with an inductive reactance of 10 ohms; (c) a voltage source $E_x = 50/90^\circ$ volts (sensed in the same direction as E_s) in series with a capacitive reactance of 10 ohms.

Ans. -250 watts; 1250 watts; 2000 watts

12-4 Find the average power delivered to a 20-ohm resistor by a current waveform described as follows: (a) 2 amp, constant; (b) 2 amp from $t = 0$ to $t = 0.1$, 0 from $t = 0.1$ to $t = 0.2$, periodic with period of 0.2 sec; (c) 2 amp from $t = 0$ to $t = 0.1$, -2 amp from $t = 0.1$ to $t = 0.2$, periodic with period of 0.2 sec.

Ans. 80 watts; 80 watts; 40 watts

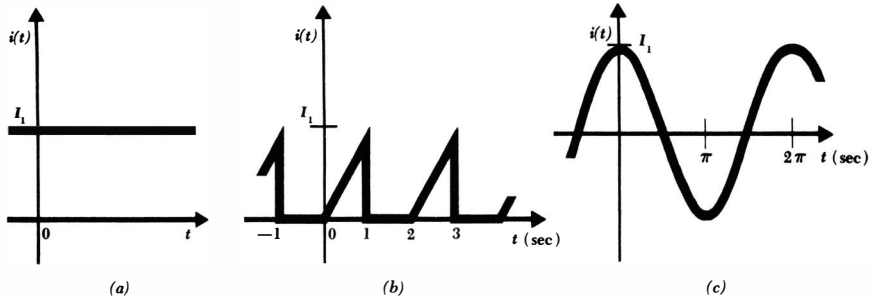

Fig. 12-6 See Drill Probs. 12-5 and 12-9.

12-5 Each of the three periodic waveforms illustrated in Fig. 12-6 is to deliver 1 watt to a 1-ohm resistor. Find I_1 in each case.

Ans. 1 amp; 2.45 amp; 1.41 amp

12-6 Determine the power delivered to a 1-ohm resistor by each of the following voltages: (a) $6 \cos 2\pi t + 8 \cos 3\pi t$ volts; (b) $4 \cos 2\pi t + 9 \sin 3\pi t$ volts; (c) $7 \cos 2\pi t + 7 \sin (3\pi t + \pi/6)$ volts.

Ans. 48.5 watts; 49.0 watts; 50.0 watts

12-7 Determine the power delivered to a 50-ohm resistor by each of these voltages: (a) $10 \sin 2000\pi t + 2 \cos 5000\pi t$ volts; (b) $10 \sin 2000\pi t + 2 \cos 2000\pi t$ volts; (c) $10 \sin 2000\pi t + 2 \sin 2000\pi t$ volts.

Ans. 1.04 watts; 1.44 watts; 1.04 watts

12-4 USE OF THE WATTMETER

The measurement of power is most often accomplished at frequencies below a few hundred cycles per second through the use of a wattmeter which contains two separate coils. One of these coils is made of heavy wire, having a very low resistance, and is called the *current coil*; the second coil is composed of a much greater number of turns of fine wire, with relatively high resistance, and is termed the *potential coil*, or *voltage coil*. Additional resistance may also be inserted internally or externally in series with the potential coil. The torque applied to the moving system and the pointer is proportional to the instantaneous product of the currents flowing in the two coils. The mechanical inertia of the moving system, however, causes a deflection which is proportional to the *average* value of this torque.

The wattmeter is used by connecting it into a network in such a way that the current flowing in the current coil is the current flowing into the network and the voltage across the potential coil is the voltage across the two terminals of the

network. The current in the potential coil is thus the input voltage divided by the resistance of the potential coil. The wattmeter deflection is therefore proportional to the average power delivered to the network.

It is apparent that the wattmeter has four available terminals, and correct connections must be made to these terminals in order to obtain an upscale reading on the meter. To be specific, let us assume that we are measuring the power absorbed by a passive network. The current coil is inserted in series with one of the two conductors connected to the load, and the potential coil is installed between the two conductors, usually on the "load side" of the current coil. The potential coil terminals are often indicated by arrows, as shown in Fig. 12-7a. Each coil has two terminals, and the proper relationship between the sense of the current and voltage must be observed. One end of each coil is usually marked (+), and an upscale reading is obtained if a positive current is flowing into the (+) end of the current coil while the (+) terminal of the potential coil is positive with respect to the unmarked end. The wattmeter shown in the network of Fig. 12-7a therefore gives an upscale deflection when the network to the right is absorbing power.

A reversal of either coil, but not both, will cause the meter to *try* to deflect downscale; a reversal of both coils will never affect the reading.

As an example of the use of such a wattmeter in measuring average power, let us consider the circuit shown in Fig. 12-7b. The connection of the wattmeter is such that an upscale reading corresponds to a positive absorbed power for the network to the right of the meter, that is, the right source. The power absorbed by this source is given by

$$P = \frac{1}{2} |E_2| |I| \cos(\text{ang } E_2 - \text{ang } I)$$

Using superposition or mesh analysis, the current is found,

$$I = 11.18 / \underline{153.4^\circ}$$

Fig. 12-7 (a) A wattmeter connection which will ensure an upscale reading for the power absorbed by the passive network. (b) An example in which the wattmeter is installed to give an upscale indication of the power absorbed by the right source.

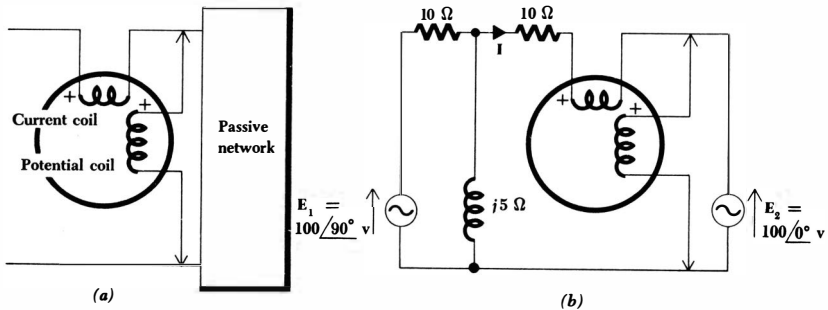

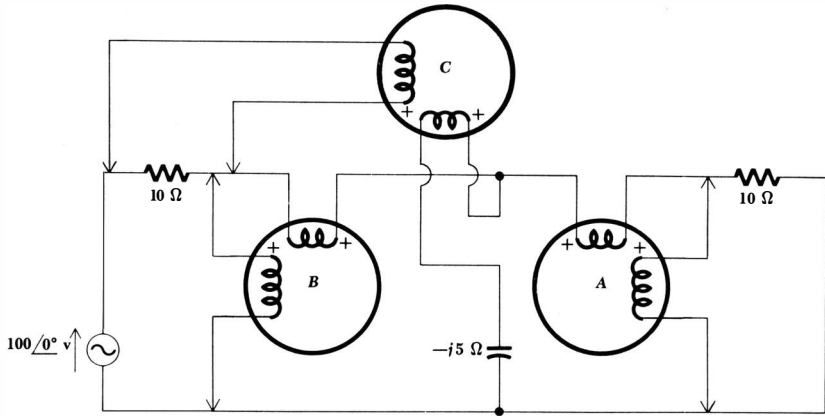

Fig. 12-8 See Drill Prob. 12-8.

and thus the absorbed power is

$$P = \frac{1}{2}(100)(11.18) \cos(0^\circ - 153.4^\circ) = -500 \text{ watts}$$

The pointer therefore rests against the downscale stop. The potential coil may be reversed more quickly in practice, and this reversal provides an upscale reading of 500 watts.

Drill Problem

12-8 In the circuit shown in Fig. 12-8, determine whether or not the potential coil must be reversed to obtain an upscale reading and find that reading for: (a) wattmeter A; (b) wattmeter B; (c) wattmeter C.

Ans. reversed, 250 watts; reversed, 62.5 watts; as is, 62.5 watts

12-5 EFFECTIVE VALUES OF CURRENT AND VOLTAGE

Most of us are aware that the voltage available at the power outlets in our homes is a sinusoidal voltage having a frequency of 60 cps and a “voltage” of 115 volts. But what is meant by “115 volts”? This is certainly not the instantaneous value of the voltage, for the voltage is not a constant. The value of 115 volts is also not the maximum value which we have been symbolizing as E_m ; if we displayed the voltage waveform on a calibrated cathode-ray oscilloscope, we should find that the maximum value of this voltage at one of our a-c outlets is $115\sqrt{2}$ or 162.6 volts. We also cannot fit the concept of an average value to the 115 volts because the average value of the sine wave is zero. We might come a little closer by trying the magnitude of the average over a positive or negative half cycle; by using a rectifier-type voltmeter at the outlet, we should measure

103.5 volts. As it turns out, however, the 115 volts is the *effective value* of this sinusoidal voltage. This value is a measure of the effectiveness of a voltage source in delivering power to a resistive load.

Let us now proceed to define the effective value of any periodic waveform representing either a current or voltage. We shall consider the sinusoidal waveform as only a special, albeit practically important, case. Let us arbitrarily define effective value in terms of a current waveform, although a voltage could equally well be selected. The *effective value* of any periodic current is equal to the value of the direct current which, flowing through a resistance R , delivers the same power to R as the periodic current does. In other words, we allow the given periodic current to flow through an arbitrary resistance R , determine the instantaneous power i^2R , and then find the average value of i^2R over a period; this is the average power. We then cause a direct current to flow through this same resistance and adjust the value of the direct current until the same value of average power is obtained. The magnitude of the direct current is equal to the effective value of the given periodic current.

The general mathematical expression for the effective value of $i(t)$ is now easily obtained. The average power delivered to the resistor by the periodic current $i(t)$ is

$$P = \frac{1}{T} \int_0^T i^2 R dt = \frac{R}{T} \int_0^T i^2 dt$$

where the period of $i(t)$ is T . The power delivered by the direct current is

$$P = I^2 R = I_{\text{eff}}^2 R$$

Equating the power expressions and solving for I_{eff} ,

$$I_{\text{eff}} = \sqrt{\frac{1}{T} \int_0^T i^2 dt} \quad (12-18)$$

The result is independent of the resistance R , as it must be to provide us with a worthwhile concept. A similar expression is obtained for the effective value of a periodic voltage by replacing i and I_{eff} by e and E_{eff} , respectively.

Notice that the effective value is obtained by first squaring the time function, then taking the average value of the squared function over a period, and finally taking the square root of the average of the squared function. In abbreviated language, the operation involved in finding an effective value is the (square) *root of the mean of the square*; for this reason, the effective value is often called the *root-mean-square* value, or simply the rms value.

The most important special case is that of the sinusoidal waveform. Let us select the sinusoidal current

$$i(t) = I_m \cos(\omega t - \theta)$$

which has a period

$$T = \frac{2\pi}{\omega}$$

and substitute into Eq. (12-18) to obtain the effective value

$$\begin{aligned} I_{\text{eff}} &= \sqrt{\frac{1}{T} \int_0^T I_m^2 \cos^2(\omega t - \theta) dt} \\ &= I_m \sqrt{\frac{\omega}{2\pi} \int_0^{2\pi/\omega} [\frac{1}{2} + \frac{1}{2} \cos(2\omega t - 2\theta)] dt} \\ &= I_m \sqrt{\frac{\omega}{4\pi} [t]_0^{2\pi/\omega}} = \frac{I_m}{\sqrt{2}} \end{aligned}$$

Thus the effective value of a sinusoidal current is a real quantity which is independent of the phase angle and numerically equal to 0.707 times its maximum value. A current $\sqrt{2} \cos(\omega t - \theta)$, therefore, has an effective value of 1 amp and will deliver the same power to any resistor as will a direct current of 1 amp.

The use of the effective value also simplifies slightly the expression for the average power delivered by a sinusoidal current or voltage. For example, the average power delivered to a resistance R by a sinusoidal current is

$$P = \frac{1}{2} I_m^2 R$$

If we replace I_m by $\sqrt{2} I_{\text{eff}}$, the average power may be written

$$P = I_{\text{eff}}^2 R \quad (12-19)$$

The other familiar power expressions may also be written in terms of effective values:

$$P = E_{\text{eff}} I_{\text{eff}} \cos \theta \quad (12-20)$$

$$\text{and} \quad P = \frac{E_{\text{eff}}^2}{R} \quad (12-21)$$

The fact that the effective value is defined in terms of an equivalent d-c quantity provides us with average power formulas for resistive circuits which are identical with those used in d-c analysis.

Although we have succeeded in eliminating the factor of one-half from our average-power relationships, we must now take care to determine whether a sinusoidal quantity is expressed in terms of its maximum value or its effective value. In practice, the effective value is usually used in the fields of power transmission or distribution and of rotating machinery; in the areas of electronics and communications, the maximum value is more often used. We shall assume that the maximum value is specified unless the term rms is explicitly used.

In the sinusoidal steady state, phasor voltages and currents may be given as either effective values or maximum values; the two expressions differ only by a factor $\sqrt{2}$. The voltage $50/30^\circ$ volts is expressed in terms of a maximum value; as an rms voltage, we should write $35.35/30^\circ$ volts rms.

In order to determine the effective value of a periodic or nonperiodic waveform which is composed of the sum of a number of sinusoids of different frequencies, we may use the appropriate average power relationship (12-17)

354 Sinusoidal Analysis

developed in the previous section, rewritten in terms of the effective values of the several components,

$$P = (I_{1\text{eff}}^2 + I_{2\text{eff}}^2 + \cdots + I_{N\text{eff}}^2)R \quad (12-22)$$

These results indicate that if a sinusoidal current of 5 amp rms at 60 cps flows through a 2-ohm resistor, an average power of 50 watts is absorbed by the resistor; if a second current, say 3 amp rms at 120 cps, is also present, the absorbed power is 68 watts; however, if the second current is also at 60 cps, then the absorbed power may have any value between 8 and 128 watts, depending on the relative phase of the two current components.

We therefore have found the effective value of a current which is composed of any number of sinusoidal currents of *different* frequencies,

$$I_{\text{eff}} = \sqrt{I_{1\text{eff}}^2 + I_{2\text{eff}}^2 + \cdots + I_{N\text{eff}}^2} \quad (12-23)$$

The total current may or may not be periodic; the result is the same. The effective value of the sum of the 60- and 120-cps currents in the example above is 5.83 amp; the effective value of the sum of the two 60-cps currents may have any value between 2 and 8 amp.

Drill Problems

12-9 Let $I_1 = 10$ amp in each of the three waveforms shown in Fig. 12-6. Find the effective value of each current.

Ans. 4.08 amp; 10 amp; 7.07 amp

12-10 Find the effective value of each of the voltages described in Drill Prob. 12-6.

Ans. 6.96 volts; 7.00 volts; 7.07 volts

12-11 Find the effective value of each of the voltage waveforms described below.

(a) $e = 15$ volts, $0 < t \leq 0.01$; $e = 30$ volts, $0.01 < t \leq 0.02$; $T = 0.02$

(b) $e = 80$ volts, $0 < t \leq 0.01$; $e = 0$, $0.01 < t \leq 0.1$; $T = 0.1$

(c) $e = 50e^{-4t}$ volts, $0 < t \leq 0.5$; $T = 0.5$

Ans. 23.7 volts; 24.8 volts; 25.3 volts

12-6 APPARENT POWER AND POWER FACTOR

Historically, the introduction of the concepts of apparent power and power factor can be traced to the electric-power industry, where large amounts of electrical energy must be transferred from one point to another; the efficiency with which this transfer is effected is related directly to the cost of the electrical energy, which is eventually paid by the consumer. A customer who provides

a load which results in a relatively poor transmission efficiency must pay a greater price for each kilowatthour of electrical energy he actually receives and uses. In a similar way, a customer who requires a costlier investment in transmission and distribution equipment by the power company will also pay more for each kilowatthour.

Let us first define apparent power and power factor and then show briefly how these terms are related to the economic situations mentioned above. We shall assume that the sinusoidal voltage

$$e = E_m \cos(\omega t + \alpha)$$

is applied to a network, and the resultant sinusoidal current is

$$i = I_m \cos(\omega t + \beta)$$

The phase angle by which the voltage leads the current is therefore

$$\theta = \alpha - \beta$$

The average power delivered to the network, assuming a passive sign convention at its input terminals, may be expressed either in terms of the maximum values,

$$P = \frac{1}{2} E_m I_m \cos \theta$$

or in terms of the effective values,

$$P = E_{eff} I_{eff} \cos \theta$$

If our applied voltage and current responses had been d-c quantities, the average power delivered to the network would have been given simply by the product of the voltage and the current. Applying this d-c technique to the sinusoidal problem, we should obtain a value for the absorbed power which is "apparently" given by the product $E_{eff} I_{eff}$. This product of the effective values of the voltage and current is not the average power; we define it as the *apparent power*. Dimensionally, apparent power must be measured in the same units as real power, since $\cos \theta$ is dimensionless, but in order to avoid confusion the term volt-amperes, or va, or kva is applied to apparent power. Since $\cos \theta$ cannot have a magnitude greater than unity, it is evident that the magnitude of the real power can never be greater than the magnitude of the apparent power.

Apparent power is not a concept which is limited to sinusoidal forcing functions and responses. It may be determined for any current and voltage wave-shape by simply taking the product of the effective values of the current and voltage. This extension of the definition of apparent power need not concern us now, but it will receive further amplification in connection with general periodic functions when Fourier analysis is discussed in the final chapter.

The ratio of the real or average power to the apparent power is called the *power factor*, symbolized by P.F. Hence,

$$\text{P.F.} = \frac{\text{average power}}{\text{apparent power}} = \frac{P}{E_{eff} I_{eff}}$$

In the sinusoidal case, the power factor is simply $\cos \theta$, where θ is the angle by which the voltage leads the current. This relationship is the reason why the angle θ is often referred to as the *power-factor angle*.

For a purely resistive load, the voltage and current are in phase, θ is zero, and the power factor is unity. The apparent power and the average power are equal. A unity power factor, however, may also be achieved for loads which contain both inductance and capacitance if the element values and the operating frequency are selected to provide an input impedance having a zero phase angle.

A purely reactive load, that is, one containing no resistance, will cause a phase difference between the voltage and current of either plus or minus 90° , and the power factor is therefore zero.

Between these two extreme cases there are the general networks for which the power factor can range from zero to unity. A power factor of 0.5, for example, indicates a load having an input impedance with a phase angle of either 60° or -60° ; the former describes an inductive load, since the voltage leads the current by 60° , while the latter refers to a capacitive load. The ambiguity in the exact nature of the load is resolved by referring to a leading power factor or a lagging power factor, the term leading or lagging referring to the *phase of the current with respect to the voltage*. Thus, an inductive load will have a lagging power factor and a capacitive load a leading power factor.

The practical importance of these new terms is shown by the several examples which follow. Let us first assume that we have a sinusoidal a-c generator, which is a rotating machine driven by some other device whose output is a mechanical torque such as a steam turbine, an electric motor, or an internal-combustion engine. We shall let our generator produce an output voltage of 200 volts rms at 60 cps. Suppose now that an additional rating of the generator is stated as a maximum power output of 1 kw. The generator would therefore be capable of delivering an rms current of 5 amp to a resistive load. If, however, a load requiring 1 kw at a lagging power factor of 0.5 is connected to the generator, then an rms current of 10 amp is necessary. As the power factor decreases, greater and greater currents must be delivered to the load if operation at 200 volts and 1 kw is maintained. If our generator were correctly and economically designed to furnish safely a maximum current of 5 amp, then these greater currents would cause unsatisfactory operation. The rating of the generator is more informatively given in terms of apparent power in volt-amperes. Thus a 1000-va rating at 200 volts indicates that the generator can deliver a maximum current of 5 amp at rated voltage; the power it delivers depends on the load, and in an extreme case might be zero. An apparent power rating is equivalent to a current rating when operation is at a constant voltage.

When electric power is being supplied to large industrial consumers by a power company, the company will frequently include a power-factor clause in its rate schedules. Under this clause, an additional charge is made to the consumer whenever his power factor drops below a certain specified value, usually about 0.85 lagging. Very little industrial power is consumed at leading power factors because of the nature of the typical industrial loads. There are

several reasons that force the power company to make this additional charge for low power factors. In the first place, it is apparent that larger current-carrying capacity must be built into its generators in order to provide the larger currents that go with lower power-factor operation at constant power and constant voltage. Another reason is found in the increased losses in its transmission and distribution system.

As an example, let us suppose that a certain consumer is using an average power of 11 kw at unity power factor and 220 volts rms. We may also assume a total resistance of 0.2 ohm in the transmission lines through which the power is delivered to the consumer. An rms current of 50 amp therefore flows in the load and in the lines, producing a line loss of 500 watts. In order to supply 11 kw to the consumer, the power company must generate 11.5 kw (at the higher voltage, 230 volts). Since the energy is necessarily metered at the location of each consumer, this consumer would be billed for 95.6 per cent of the energy which the power company actually produced.

Now let us hypothesize another consumer, also requiring 11 kw, but at a power-factor angle of 60° lagging. This consumer forces the power company to push 100 amp through his load and (of particular interest to the company) through the line resistance. The line losses are now found to be 2 kw, and the customer's meter indicates only 84.6 per cent of the actual energy generated. This figure departs from 100 per cent by more than the power company will tolerate; this costs it money. Of course, the transmission losses might be reduced by using heavier transmission lines which have lower resistance, but this costs more money too. The power company's solution to this problem is to encourage operation at power factors which exceed 0.9 lagging by offering slightly reduced rates and to discourage operation at power factors which are less than 0.85 lagging by invoking increased rates.

The power drawn by most homes is used at reasonably high power factors (and reasonably small power levels); no charge is customarily made for low power-factor operation.

Besides paying for the actual energy consumed and for operation at excessively low power factors, industrial consumers are also billed for inordinate *demand*. An energy of 100 kwhr is delivered much more economically as 5 kw for 20 hr than it is as 20 kw for 5 hr.

Drill Problems

12-12 Find the power factor which is associated with a load: (a) drawing 10 kva and 8 kw; (b) requiring 23 kw at 230 volts rms and 150 amp rms; (c) composed of a resistor R in parallel with a $100\text{-}\mu\text{f}$ capacitor, the combination using 3 kva at 230 volts rms, 60 cps.

Ans. 0.8; 0.667; 0.748

12-13 A load consists of a resistance R in parallel with a reactance X . Find X if: (a) $R = 10$ ohms and P.F. = 0.5 lagging; (b) the load draws 2 kva from a 100-volt rms 60-cps system at a leading power fac-

tor of 0.8; (c) the load current is 20 amp rms, the load voltage is 200 volts rms, and the load power factor is 0.707 leading.

Ans. -8.33 ohms; -14.14 ohms; 5.77 ohms

12-7 COMPLEX POWER

Some simplification in power calculations is achieved if power is considered to be a complex quantity. The magnitude of the complex power will be found to be the apparent power, and the real part of the complex power will be shown to be the (real) average power. The new quantity, the imaginary part of the complex power, we shall call *reactive power*.

We shall define complex power with reference to a general sinusoidal voltage $\mathbf{E}_{eff} = E_{eff}/\theta_e$ across a pair of terminals and a general sinusoidal current $\mathbf{I}_{eff} = I_{eff}/\theta_i$ flowing into one of the terminals in such a way as to satisfy the passive sign convention. The average power P absorbed by the two-terminal network is thus

$$P = E_{eff}I_{eff} \cos(\theta_e - \theta_i)$$

Complex nomenclature is next introduced by making use of Euler's formula in the same way as we did in introducing phasors. We express P as

$$P = E_{eff}I_{eff} \operatorname{Re}[\epsilon^{j(\theta_e - \theta_i)}]$$

$$\text{or } P = \operatorname{Re}[E_{eff}\epsilon^{j\theta_e}I_{eff}\epsilon^{-j\theta_i}]$$

The phasor voltage may now be recognized as the first term within the brackets in the equation above, but the second term does not quite correspond to the phasor current because the angle includes a minus sign which is not present in the expression for the phasor current. In other words, the phasor current is

$$\mathbf{I}_{eff} = I_{eff}\epsilon^{j\theta_i}$$

and we therefore must make use of conjugate notation,

$$\mathbf{I}_{eff}^* = I_{eff}\epsilon^{-j\theta_i}$$

Hence

$$P = \operatorname{Re}(\mathbf{E}_{eff}\mathbf{I}_{eff}^*)$$

and we may now let power become complex by defining the complex power \mathbf{P} as

$$\mathbf{P} = \mathbf{E}_{eff}\mathbf{I}_{eff}^* \quad (12-24)$$

If we first inspect the polar or exponential form of the complex power

$$\mathbf{P} = E_{eff}I_{eff}\epsilon^{j(\theta_e - \theta_i)}$$

it is evident that the magnitude of \mathbf{P} is the apparent power, and the angle of \mathbf{P} is the power-factor angle, that is, the angle by which the voltage leads the current. In rectangular form,

$$\mathbf{P} = P + jQ \quad (12-25)$$

Fig. 12-9 The current phasor \mathbf{I}_{eff} is resolved into two components, one in phase with the voltage phasor \mathbf{E}_{eff} and the other 90° out of phase with the voltage phasor. This latter component is called a quadrature component.

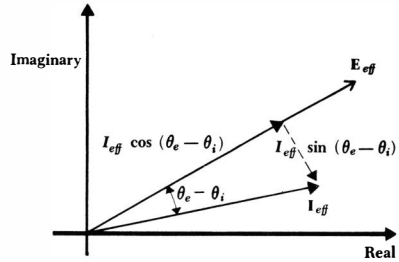

where P is the real average power, as before.¹ The imaginary part of the complex power is symbolized as Q and is termed the *reactive power*. The dimensions of Q are obviously the same as those of the real power P , the complex power \mathbf{P} , and the apparent power $|\mathbf{P}|$. In order to avoid confusion with these other quantities, the units of Q are defined as *vars*, standing for volt-amperes reactive. From Eq. (12-24), it is seen that

$$Q = E_{eff} I_{eff} \sin(\theta_e - \theta_i)$$

Another interpretation of the reactive power may be seen by constructing a phasor diagram containing \mathbf{E}_{eff} and \mathbf{I}_{eff} , as shown in Fig. 12-9. If the phasor current is resolved into two components, one in phase with the voltage, having a magnitude $I_{eff} \cos(\theta_e - \theta_i)$, and one 90° out of phase with the voltage, with magnitude $I_{eff} \sin(\theta_e - \theta_i)$, then it is clear that the real power is given by the product of the magnitude of the voltage phasor and the component of the phasor current which is in phase with the voltage. Moreover, the product of the magnitude of the voltage phasor and the component of the phasor current which is 90° out of phase with the voltage is the reactive power Q . It is common to speak of the component of a phasor which is 90° out of phase with some other phasor as a *quadrature component*. Thus Q is simply E_{eff} times the quadrature component of \mathbf{I}_{eff} ; Q is also known as the quadrature power.

The sign of the reactive power characterizes the nature of a passive load at which \mathbf{E}_{eff} and \mathbf{I}_{eff} are specified. If the load is inductive, then $\theta_e - \theta_i$ is an angle between 0 and 90° , the sine of this angle is positive, and the reactive power is positive. A capacitive load results in a negative reactive power.

Just as a wattmeter reads the average real power drawn by a load, a varmeter will read the average reactive power Q drawn by the load. Both quantities may be metered simultaneously. In addition, watt-hour-meters and var-hour-meters may be used simultaneously to record real and reactive energy used by any consumer during any desired time interval. From these records the average power factor may be determined and the consumer's bill may be adjusted accordingly.

It is easy to show that the complex power delivered to several interconnected loads is the sum of the complex powers delivered to each of the individual loads,

¹ It should be noted that P is not the magnitude of \mathbf{P} , although such nomenclature has been used previously. For example, E_{eff} is the magnitude of \mathbf{E}_{eff} , Z_L is the magnitude of \mathbf{Z}_L , and so forth.

Fig. 12-10 A circuit used to show that the complex power drawn by two parallel loads is the sum of the complex powers drawn by the individual loads.

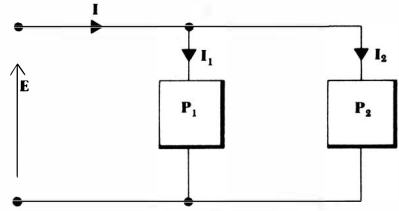

no matter how the loads are interconnected. For example, consider the two loads shown connected in parallel in Fig. 12-10. If rms values are assumed, the complex power drawn by the combined loads is

$$\mathbf{P} = \mathbf{E}\mathbf{I}^* = \mathbf{E}(\mathbf{I}_1 + \mathbf{I}_2)^* = \mathbf{E}(\mathbf{I}_1^* + \mathbf{I}_2^*)$$

and thus

$$\mathbf{P} = \mathbf{E}\mathbf{I}_1^* + \mathbf{E}\mathbf{I}_2^*$$

as stated.

These new ideas can be clarified by a practical numerical example. Let us suppose that an industrial consumer is operating a 1-kw induction motor at a lagging power factor of 0.8. In order to obtain lower electrical rates, he wishes to raise his power factor to 0.95 lagging. Although the power factor might be raised by increasing his real power and maintaining the reactive power constant, this would not result in a lower bill; this cure therefore does not interest the consumer. A purely reactive load must be added to the system, and it is clear that it must be added in parallel, since the supply voltage to the induction motor must not change. The circuit of Fig. 12-10 is thus applicable if we interpret \mathbf{P}_1 as the induction motor power and \mathbf{P}_2 as the complex power drawn by the corrective device. Let us assume a voltage of $200\angle 0^\circ$ volts rms.

The complex power supplied to the induction motor must have a real part of 1000 watts and an angle of $\cos^{-1}(0.8)$. Hence,

$$\mathbf{P}_1 = \frac{1000/\cos^{-1}(0.8)}{0.8} = 1000 + j750$$

In order to achieve a power factor of 0.95, the total complex power must become

$$\mathbf{P} = \frac{1000}{0.95} \angle \cos^{-1}(0.95) = 1000 + j329$$

Thus, the complex power drawn by the corrective load is

$$\mathbf{P}_2 = -j421$$

The necessary load impedance \mathbf{Z}_2 may be found in several simple steps. The current drawn by \mathbf{Z}_2 is

$$\mathbf{I}_2^* = \frac{\mathbf{P}_2}{\mathbf{E}} = \frac{-j421}{200} = -j2.105$$

or $\mathbf{I}_2 = j2.105$

361 Average Power and RMS Values

and, therefore,

$$Z_2 = \frac{E}{I_2} = \frac{200}{j2.105} = -j95.0 \text{ ohms}$$

If the operating frequency is 60 cps, this load can be provided by a 27.9- μ f capacitor. The load may also be simulated by a synchronous capacitor, a type of rotating machine, although this is usually economical only for much smaller capacitive reactances. Whatever device is selected, its initial costs, maintenance, and depreciation must be covered by the reduction in the electric bill.

Drill Problem

12-14 Find the complex power delivered to a load: (a) absorbing 100 watts at a power factor of 0.08 leading; (b) requiring 2 kva at a power factor of 0.9 lagging; (c) having an impedance of $15 + j10$ ohms and operating at an rms voltage of 230 volts.

Ans. $1800 + j870$ va; $100 - j1246$ va; $2440 + j1627$ va

Problems

- 1 Determine and graph the instantaneous power delivered by the source in each circuit shown in Fig. 12-11.
- ◆2 A unit-step voltage source is connected to the series combination of a 1-ohm resistor and a 1-farad capacitor. (a) Find the instantaneous power $p(t)$. (b) Find the average power delivered in a 1-sec interval beginning at: (1) $t = 0$; (2) $t = 1$ sec; (3) $t = 10$ sec.
- 3 Find the average power delivered by the source in each of the circuits shown in Fig. 12-12. Work each problem first in such a way as to obtain the total average power directly; then determine independently the power absorbed by each element and add to check the total.
- ◆4 Each of the resistive loads shown in the circuit of Fig. 12-13a draws 1.5 watts average power. If $R_2 = 7500$ ohms, find R_1 and $|\mathbf{E}_s|$.
- 5 Find the average power being delivered to the 2-ohm resistor in the circuit of Fig. 12-13b.
- ◆6 Find the frequency at which the average power delivered to the resistor in the circuit of Fig. 12-14a is a maximum. Also determine the maximum power.

Fig. 12-11 See Prob. 1.

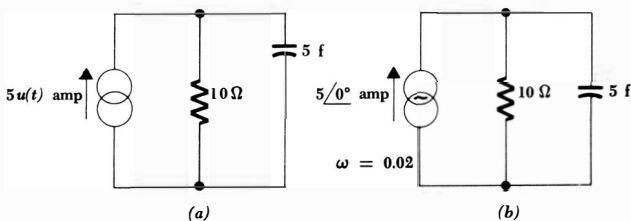

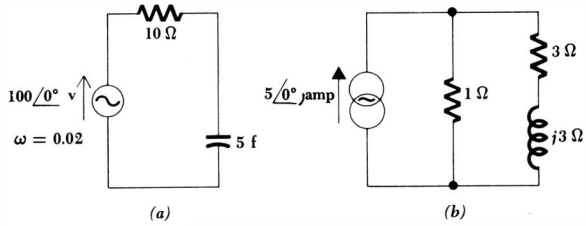

Fig. 12-12 See Prob. 3.

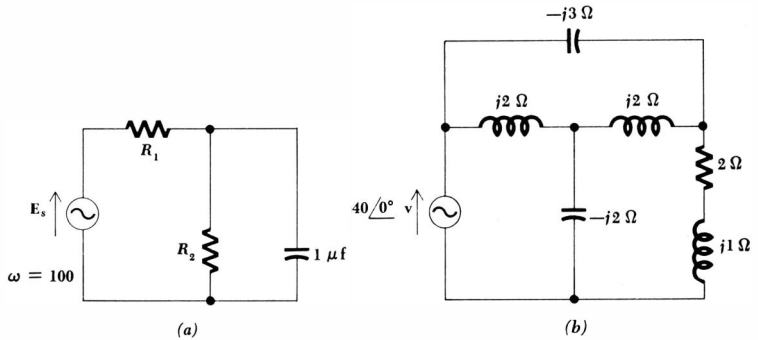

Fig. 12-13 (a) See Prob. 4. (b) See Prob. 5.

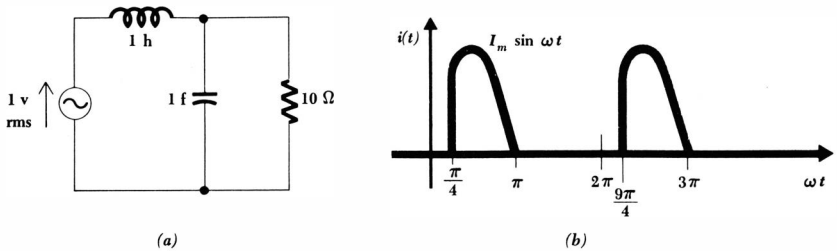

Fig. 12-14 (a) See Prob. 6. (b) See Prob. 7.

- 7 Determine both the effective value and the average value of the current waveform shown in Fig. 12-14b.
- 8 If $i_1(t) = 10 \cos 2\omega_0 t + 20 \cos 5\omega_0 t$ and $i_2(t) = I_0 + 5 \cos \omega_0 t$, find two values for I_0 such that $I_1 \text{ eff} = I_2 \text{ eff}$.
- 9 A resistor R and a reactance X are in series with an ideal sinusoidal voltage source. A good laboratory a-c voltmeter indicates 150 volts across the source and 100 volts across the reactance. A good wattmeter is used to find the average power delivered by the source, 100 watts. Find R , X , and the rms current.

- ◆10 In the circuit shown in Fig. 12-15a, $E_s = 10$ volts rms and $E_2 = 6$ volts rms. What average power is being delivered by the source?
- 11 The elements in the circuit of Fig. 12-15b which are identified as A_1 and A_2 are ideal a-c ammeters. A_1 reads 5 amp rms, and A_2 reads 2 amp rms. A wattmeter connected to the source indicates a generated power of 100 watts. Find C .
- ◆12 The current whose waveshape is shown in Fig. 12-16a is applied as a current source to the circuit of Fig. 12-16b. (a) Find the rms value of $i(t)$. (b) Find the average power absorbed by the resistor. (c) Assume that the capacitor is uncharged at $t = 0$ and sketch $e_c(t)$ for the interval $0 < t < 3$.
- 13 In the circuit shown in Fig. 12-17, assume that $\mathbf{E}_{L1} = E_L/0^\circ$, $\mathbf{E}_{L2} = E_L/120^\circ$, and $\mathbf{E}_{L3} = E_L/240^\circ$, where E_L is an rms voltage. If $\mathbf{Z}_L = \mathbf{Z}_L/\theta$, show that the magnitudes of the three currents \mathbf{I}_{L1} , \mathbf{I}_{L2} , and \mathbf{I}_{L3} are equal. If this rms magnitude is denoted as I_L , then show that the total power delivered to the three impedances is $\sqrt{3}E_L I_L \cos \theta$.
- ◆14 Find the rms phasor current drawn by the load of Fig. 12-18a if the power factor is: (a) 0.5 leading; (b) 0.5 lagging; (c) 0.01 lagging.
- 15 Find the two possible values of inductive reactance which will cause the circuit of Fig. 12-18b to have unity power factor.
- ◆16 It is known that the magnitude of the impedance \mathbf{Z} in the circuit shown in Fig. 12-19a is 20 ohms and that it absorbs an average power of 6400 watts. If the total average power generated by the source is 7200 watts, find: (a) $|\mathbf{I}|$ rms; (b) $|\mathbf{E}_L|$ rms; (c) the power factor of the impedance \mathbf{Z} .

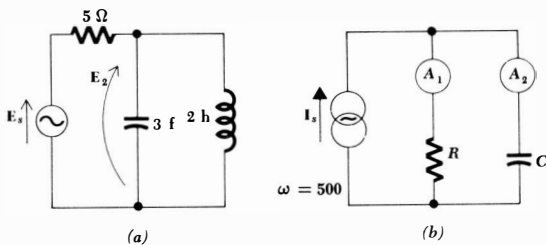

Fig. 12-15 (a) See Prob. 10. (b) See Prob. 11.

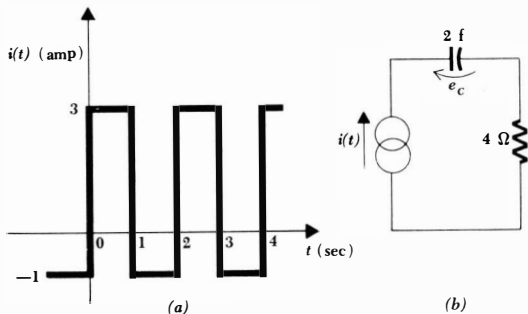

Fig. 12-16 See Prob. 12.

364 Sinusoidal Analysis

- 17 An industrial concern draws an average power of 100 kw at a lagging power factor of 0.7 from a 2300-volt rms 60-cps system. What size capacitor should be added across the load to raise the power factor to: (a) 0.85; (b) 0.90; (c) 1?
- 18 Find the complex power generated by the source of the circuit of Fig. 12-19*b* and the complex power delivered to each of the three passive circuit elements.
- 19 The phasor voltage and current are given for several different elements in Fig. 12-20. Find for each element: (a) whether the element is active or passive; (b) if passive, whether inductive or capacitive; (c) if active, whether it is acting into an inductive or a capacitive load; (d) the average power involved.

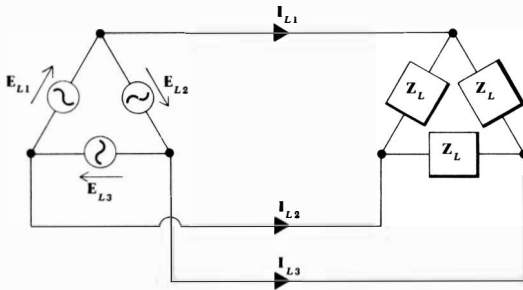

Fig. 12-17 See Prob. 13.

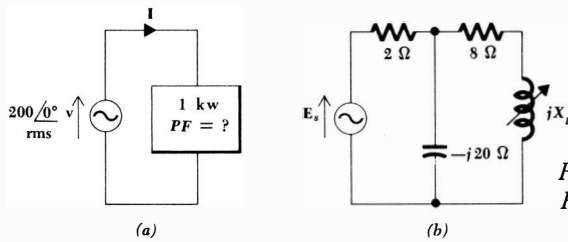
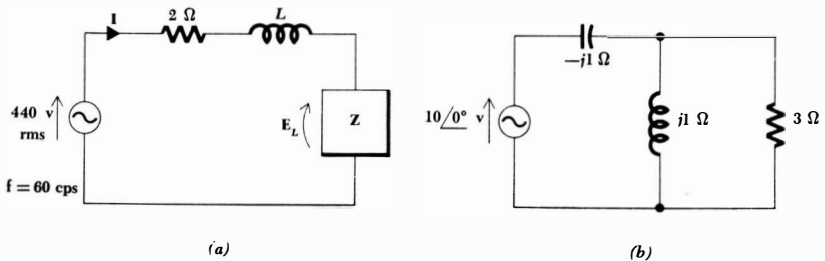

Fig. 12-18 (a) See Prob. 14. (b) See Prob. 15.

Fig. 12-19 (a) See Prob. 16. (b) See Prob. 18.



- 20 Find the complex power delivered by each source and absorbed by each element in the circuit of: (a) Fig. 12-21a; (b) Fig. 12-21b.
- ◆21 Find the average power furnished by the left current source in the circuit shown in Fig. 12-22a.
- 22 Determine the reading of the wattmeter in the circuit of Fig. 12-7b if the inductor is replaced by a capacitor having a reactance of -5 ohms. Is it necessary to reverse the potential coil to obtain an upscale reading?
- 23 For the circuit shown in Fig. 12-22b: (a) find the impedance which the source faces; (b) draw the equivalent time-domain circuit if $\omega = 10^5$; (c) find I_L and $i_L(t)$; (d) determine the Thévenin equivalent of the network to the left of the right inductor; (e) show that the power dissipated in the Thévenin equivalent is not the same as the power dissipated in the original network; (f) show that the power dissipated in the right inductor is the same

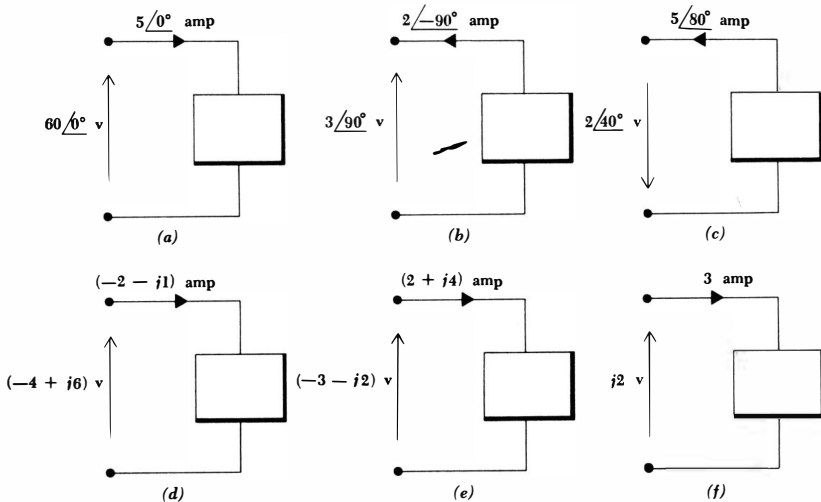
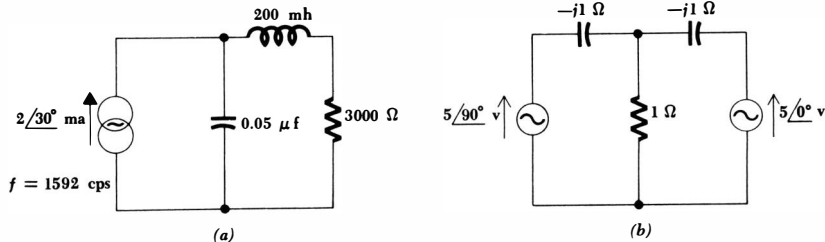

Fig. 12-20 See Prob. 19.

Fig. 12-21 See Prob. 20.



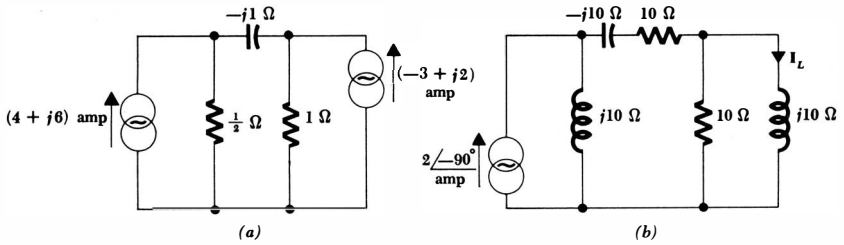

Fig. 12-22 (a) See Prob. 21. (b) See Prob. 23.

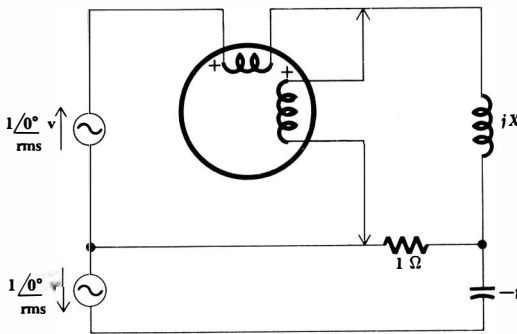

Fig. 12-23 See Prob. 26.

- in both circuits; (g) sketch a phasor diagram showing all currents and voltages throughout the Thévenin equivalent circuit; (h) find the reactive power delivered to the right inductor.
- ◆24 An ideal sinusoidal source $E_s = 100/30^\circ$ volts rms supplies two loads connected in parallel. One load requires 100 watts at an 0.8 lagging power factor, and the other draws 200 watts at unity power factor. (a) Find the average power delivered by the source. (b) Find the reactive power delivered by the source. (c) Find the phasor current through the source.
 - 25 An ideal voltage source $e_s(t) = 100 \cos 10^3t$ volts is in series with a 100-mh inductor and a 100-ohm resistor. (a) What is the rms source voltage? (b) What is the average value of the source current? (c) What average power is delivered by the source? (d) What complex power is delivered by the source? (e) What is the maximum instantaneous value of the power absorbed by the inductor? (f) By the resistor?
 - ◆26 For the circuit shown in Fig. 12-23: (a) What value of inductive reactance X will cause zero deflection of the wattmeter? (b) What value of inductive reactance will produce an upscale reading of 1 watt? (c) What value of inductive reactance will cause an initial downscale reading and, upon reversal of the potential coil, an upscale reading of 0.2 watt?

Part

Four:

Complex

Frequency

Chapter *13* *The Exponential Forcing Function*

13-1 INTRODUCTION

We are now about to begin the fourth major portion of our study of circuit analysis, a discussion of the concept of complex frequency. This, we shall see, is a remarkably unifying concept which will enable us to tie together all our previously developed analytical techniques into one neat package. Resistive circuit analysis, steady-state sinusoidal analysis, transient analysis, the forced response, the complete response, and the analysis of circuits excited by exponential forcing functions and exponentially damped sinusoidal forcing functions will all become special cases of the general techniques which are associated with the complex-frequency concept.

Complex frequency itself will not be introduced until the next chapter. We shall first take the more gradual step of considering the forced and complete response of circuits excited with an exponential forcing function. This short chapter will conclude with a discussion of the variation of the response of a circuit with frequency.

When the sinusoidal forcing function was introduced, the justification for its early study was based on the fact that it had already appeared as a natural response, on its mathematical simplicity, its practicality, and its later use in Fourier series. We are now about to select the exponential forcing function as the next functional form to consider. This is also a function which we have found to arise naturally; it is the typical response of the single time-constant circuit. The mathematical analysis, moreover, is considerably easier than the sinusoidal steady-state analysis. Phasors are unnecessary, and we need deal only with real quantities. The basic reason for the mathematical ease is apparent when the exponential function is differentiated or integrated; the result is an exponential function of the same form. If it were not for the relatively rare occurrence of an exponential forcing function in practice and for our need of extensive practice with phasor algebra, we should certainly have considered the

exponential function before the sinusoidal function. The Fourier series justification cannot be extended easily to include the exponential forcing function; instead, we shall let this forcing function lead us directly to the concept of a complex frequency.

We shall consider forcing functions of the form

$$E_m e^{\sigma t}$$

where σ (sigma) is a real quantity and is usually negative. Our work with the simplest natural responses also indicates that σ is the negative of the exponential damping coefficient. If we compare this function with the complex representation of a sinusoidal forcing function

$$E_m e^{j\omega t}$$

it is apparent that the two functions have much in common. Their only difference is in the presence of a real and an imaginary exponent. The similarity between the two functions is emphasized by describing σ as a "frequency." This choice of terminology will be discussed in detail in the following chapter, and at the present time we need merely note that σ is specifically termed the real part of the complex frequency. It should not be called the "real frequency," however, for this is a term which is more suitable for f (or, loosely, for ω). We shall also refer to σ as the *neper frequency*, the name arising from the dimensionless unit of the exponent of e . Thus, given e^{2t} , the dimensions of $2t$ are nepers, and 2 is the neper frequency in nepers per second. The neper itself was named after Napier and his Napierian logarithm system; the spelling of his name is historically uncertain.

13-2 STEADY-STATE RESPONSE TO EXPONENTIAL FORCING FUNCTIONS

In the last four chapters we have expended considerable effort in developing a simplified method for determining the steady-state response due to a sinusoidal forcing function. Now we shall see that, with very little modification, this method is equally applicable to the exponential forcing function and its response. The slight differences which occur tend to simplify the procedure.

In order to develop a simple analytical method for the exponential forced response, let us briefly review our approach to sinusoidal analysis. Our concern was with the forced or steady-state response, that part of the response which has the same mathematical form as the forcing function itself, its derivatives, and integrals. The sinusoidal forcing function thus produces a sinusoidal forced response at the same radian frequency, but with a magnitude and phase angle which depend upon the network as well as the forcing function. We therefore found that we need determine only this magnitude and phase angle in order to specify the response exactly.

These two quantities were most easily obtained by analyzing the circuit in the frequency domain rather than the time domain. We replaced a real forcing

function, such as $E_m \cos(\omega t + \theta)$, by a complex forcing function $E_m \epsilon^{j(\omega t + \theta)}$ whose real part was identical with the given time-domain forcing function. After writing the appropriate network equations, it was possible to avoid writing $\epsilon^{j\omega t}$ since it was a common factor of every term. The forcing function became the phasor $E_m \epsilon^{j\theta}$ or $E_m \angle \theta$, and a general current response, such as $I_m \cos(\omega t + \phi)$, became $I_m \angle \phi$.

The unknown magnitude and phase angle of the desired response were obtained by defining an impedance as the phasor-voltage to phasor-current ratio across each type of element and by showing that Kirchhoff's laws, mesh analysis, nodal analysis, and all the other methods developed for resistive circuits were also applicable to circuits described in terms of phasors and impedances.

Now let us consider applying this same procedure when an exponential forcing function is applied to a general *RLC* network. The forced response is desired. Let us assume that a voltage forcing function is applied,

$$e(t) = E_m \epsilon^{\sigma t}$$

where E_m , the value of $e(t)$ at $t = 0$, may be termed once again the amplitude of the exponential voltage forcing function and σ is the real part of the complex frequency. A knowledge of E_m and σ enables us to describe $e(t)$ completely; in the sinusoidal case, the three quantities E_m , θ , and ω were required. Suppose that this voltage is applied¹ to a series *RLC* circuit, and we wish to find the resultant current $i(t)$. Because the derivatives and integrals of an exponential function are unchanged in form, the desired forced response must be describable as

$$i(t) = I_m \epsilon^{\sigma t}$$

where only one quantity is unknown, the magnitude I_m . Let us first find it by writing the loop equations for this circuit:

$$e(t) = Ri + L \frac{di}{dt} + \frac{1}{C} \int i dt$$

It should be noted that an integration constant is not necessary since the form of the forced response is already known; it does not and cannot contain a constant term. Substituting the known form of $i(t)$ into the single loop equation, we obtain

$$E_m \epsilon^{\sigma t} = RI_m \epsilon^{\sigma t} + LI_m \sigma \epsilon^{\sigma t} + \frac{I_m}{\sigma C} \epsilon^{\sigma t}$$

We now suppress $\epsilon^{\sigma t}$ and obtain the trivial real algebraic equation

$$E_m = RI_m + \sigma LI_m + \frac{I_m}{\sigma C}$$

¹ If $\sigma < 0$, it is apparent that this voltage could not have been applied at $t = -\infty$; if it were, then the voltage would have been infinite. We shall consider the accompanying natural response shortly.

371 The Exponential Forcing Function

from which the desired value of I_m is readily determined,

$$I_m = \frac{E_m}{R + \sigma L + 1/\sigma C}$$

By comparing the above procedure with the earlier procedure used for sinusoidal steady-state analysis, the last result may be described as the frequency-domain solution. The equivalent time-domain expression is evidently

$$i(t) = \frac{E_m}{R + \sigma L + 1/\sigma C} \epsilon^{\sigma t}$$

The above method of solution may be extended to apply to any general linear network excited by the single forcing function $E_m \epsilon^{\sigma t}$ or by a current source of similar form if desired. Our solution would begin by writing a number of mesh or nodal equations, each term of which would contain the common factor $\epsilon^{\sigma t}$. When this term is suppressed, the forcing function or response is transformed to the frequency domain. Specifically, then, the time-domain quantity

$$e(t) = E_m \epsilon^{\sigma t}$$

is transformed to the frequency domain by merely suppressing $\epsilon^{\sigma t}$,

$$E = E_m$$

Comparing this transformation with that used in the sinusoidal steady-state case where it was necessary to convert the time-domain description into the real part of a complex exponential representation, drop the real-part operator, and suppress $\epsilon^{j\omega t}$, we should see that these steps which were necessary in the sinusoidal steady state *are still applicable* to the exponential case; however, they are *not necessary* since we are now dealing with consistently real quantities. Thus, we might transform from the time domain to the frequency domain by these steps:

$$e(t) = E_m \epsilon^{\sigma t} = \text{Re} (E_m \epsilon^{\sigma t})$$

and thus

$$E = E_m$$

but it is apparent that the second step is a waste of time; we may immediately suppress $\epsilon^{\sigma t}$.

The frequency-domain description of an exponential forcing function is a (positive or negative) real number. The transformation back to the time domain is achieved by replacing the missing $\epsilon^{\sigma t}$ factor.

The impedance concept is also applicable to the exponential response. Let us define the impedance $Z(\sigma)$ as the ratio of the frequency-domain voltage to the frequency-domain current. A passive sign convention is assumed. The impedances of the three simple elements are easily found. For the resistor,

$$\begin{aligned} e(t) &= Ri(t) \\ E_m \epsilon^{\sigma t} &= RI_m \epsilon^{\sigma t} \\ E &= IR \end{aligned}$$

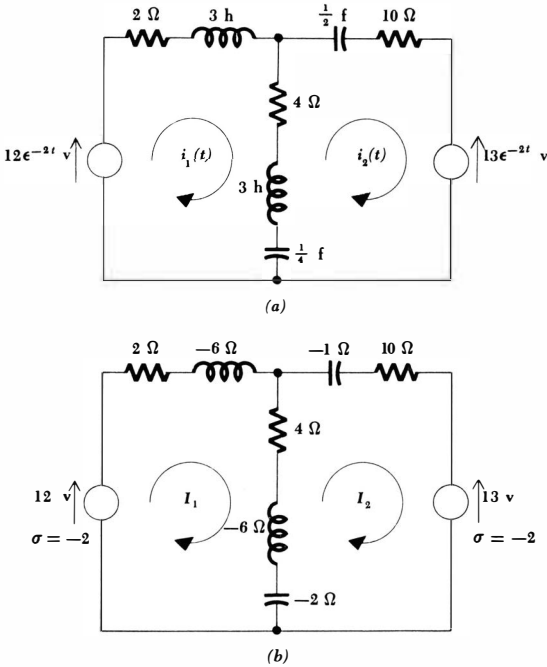

Fig. 13-1 (a) A circuit containing two exponential forcing functions is shown in the time domain. (b) The frequency-domain circuit.

and thus

$$Z(\sigma) = R$$

In the case of the inductor,

$$e(t) = L \frac{di}{dt}$$

$$E_m e^{\sigma t} = \sigma L I_m e^{\sigma t}$$

$$E_m = \sigma L I_m$$

$$E = \sigma L I$$

and, therefore,

$$Z(\sigma) = \frac{E}{I} = \sigma L$$

A similar analysis of the capacitor yields the impedance

$$Z(\sigma) = \frac{1}{\sigma C}$$

The close similarity between these impedances and the corresponding sinusoidal steady-state impedances can hardly go unnoticed. The only difference lies in the interchange of $j\omega$ and σ . Since we have already anticipated complex fre-

371 The Exponential Forcing Function

from which the desired value of I_m is readily determined,

$$I_m = \frac{E_m}{R + \sigma L + 1/\sigma C}$$

By comparing the above procedure with the earlier procedure used for sinusoidal steady-state analysis, the last result may be described as the frequency-domain solution. The equivalent time-domain expression is evidently

$$i(t) = \frac{E_m}{R + \sigma L + 1/\sigma C} \epsilon^{\sigma t}$$

The above method of solution may be extended to apply to any general linear network excited by the single forcing function $E_m \epsilon^{\sigma t}$ or by a current source of similar form if desired. Our solution would begin by writing a number of mesh or nodal equations, each term of which would contain the common factor $\epsilon^{\sigma t}$. When this term is suppressed, the forcing function or response is transformed to the frequency domain. Specifically, then, the time-domain quantity

$$e(t) = E_m \epsilon^{\sigma t}$$

is transformed to the frequency domain by merely suppressing $\epsilon^{\sigma t}$,

$$E = E_m$$

Comparing this transformation with that used in the sinusoidal steady-state case where it was necessary to convert the time-domain description into the real part of a complex exponential representation, drop the real-part operator, and suppress $\epsilon^{j\omega t}$, we should see that these steps which were necessary in the sinusoidal steady state *are still applicable* to the exponential case; however, they are *not necessary* since we are now dealing with consistently real quantities. Thus, we might transform from the time domain to the frequency domain by these steps:

$$e(t) = E_m \epsilon^{\sigma t} = \text{Re} (E_m \epsilon^{\sigma t})$$

and thus

$$E = E_m$$

but it is apparent that the second step is a waste of time; we may immediately suppress $\epsilon^{\sigma t}$.

The frequency-domain description of an exponential forcing function is a (positive or negative) real number. The transformation back to the time domain is achieved by replacing the missing $\epsilon^{\sigma t}$ factor.

The impedance concept is also applicable to the exponential response. Let us define the impedance $Z(\sigma)$ as the ratio of the frequency-domain voltage to the frequency-domain current. A passive sign convention is assumed. The impedances of the three simple elements are easily found. For the resistor,

$$\begin{aligned} e(t) &= Ri(t) \\ E_m \epsilon^{\sigma t} &= RI_m \epsilon^{\sigma t} \\ E &= IR \end{aligned}$$

quency by calling σ the real part of the complex frequency, we might suspect that the radian frequency ω is the imaginary part of the complex frequency. In the case of the inductor, for example, the impedance in the sinusoidal steady state is the inductance times the purely imaginary frequency $j\omega$, and the impedance in the exponential steady state is the inductance times the purely real frequency σ . It would be a reasonable guess that the impedance of an inductor at a complex frequency is $(\sigma + j\omega)L$.

In Chap. 11 we spent a considerable amount of time showing that Kirchhoff's laws, the techniques of mesh and nodal analysis, Thévenin's and Norton's theorems, superposition, and so forth, were all applicable to phasors. It should be apparent by now that this is also true for analysis problems in which exponential forcing functions are used and described in the frequency domain. We could simply go back through our previous proofs, replace $j\omega$ by σ , and reach the same conclusions as before. Let us assume that this has been done, thus avoiding a dreary evening. We shall use these several techniques to analyze various circuits in the exponential steady state.

A time-domain circuit containing two exponential forcing functions (of the same neper frequency $\sigma = -2$) is shown in Fig. 13-1*a*. The circuit should be analyzed in the frequency domain, however. The impedance of each passive element is determined at $\sigma = -2$, the ϵ^{-2t} factor is suppressed in each forcing function, and two mesh currents I_1 and I_2 are assigned, as shown in the frequency-domain equivalent of Fig. 13-1*b*. Kirchhoff's voltage law is next applied to the first mesh:

$$(2 - 6 + 4 - 6 - 2)I_1 - (4 - 6 - 2)I_2 = 12$$

$$\text{or} \quad -8I_1 + 4I_2 = 12$$

For the right mesh, we obtain

$$-(4 - 6 - 2)I_1 + (-2 - 6 + 4 - 1 + 10)I_2 = -13$$

$$\text{or} \quad 4I_1 + 5I_2 = -13$$

Solution by determinants or elimination of variables enables us to find

$$I_1 = -2 \quad I_2 = -1$$

The time-domain currents are easily written by reinserting the missing exponential factors

$$i_1(t) = -2\epsilon^{-2t} \quad i_2(t) = -1\epsilon^{-2t}$$

Other analysis methods may be used once the frequency-domain circuit is determined. For example, we may first simplify the frequency-domain circuit by combining the series impedances, obtaining the equivalent circuit shown in Fig. 13-2. The superposition principle now allows us to find I_1 as the sum of two partial responses. With the 13-volt source dead,

$$I_{1a} = \frac{12}{-4 + (-4)(9)/(-4 + 9)} = -\frac{15}{14}$$

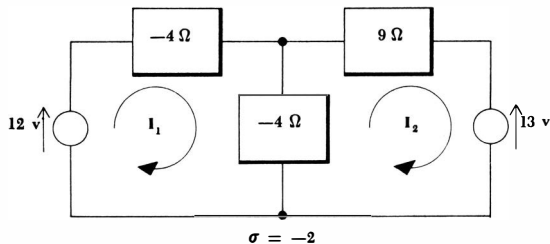

Fig. 13-2 A simplified equivalent of the frequency-domain circuit of Fig. 13-1b.

while the 13-volt source acting alone provides

$$I_{1b} = -\frac{13}{9 + (-4)(-4)/(-4 - 4)} \frac{-4}{-4 - 4} = -\frac{13}{14}$$

Once again,

$$I_1 = I_{1a} + I_{1b} = -2$$

The analysis of this same circuit through the use of source transformations and nodal analysis, and also by using Thévenin's theorem, is requested in problems at the end of the chapter.

One point is worth elaboration. The impedance of the central branch of the above circuit was found to be -4 ohms. In our study of the resistive circuit we learned that a negative resistance is associated with a device which is capable of delivering energy to the remainder of the circuit. This negative 4-ohm impedance is also delivering energy to the rest of the circuit. For example, the current flowing downward through this central branch is

$$i_1(t) - i_2(t) = -1\epsilon^{-2t}$$

The voltage across the branch, reference arrowhead at the top, is

$$E = -4(I_1 - I_2) = 4$$

or
$$e(t) = 4\epsilon^{-2t}$$

The power absorbed by the branch is therefore

$$p = ei = -4\epsilon^{-4t}$$

The absorbed power is negative for all time, and thus this branch continuously delivers energy to the remainder of the circuit. Certainly, as time increases the forcing functions decay exponentially, the forced responses decay exponentially, and all the stored energy disappears. It seems plausible that, say, a series RL circuit may act as a source if the power delivered by the inductor is greater than that absorbed by the resistor. In other words, if

$$p_R = i^2 R = I_m^2 R \epsilon^{2\sigma t}$$

plus

$$\begin{aligned} p_L &= ei = iL \frac{di}{dt} \\ &= I_m^2 \sigma L \epsilon^{2\sigma t} \end{aligned}$$

375 *The Exponential Forcing Function*

is negative, we have an energy source. This obviously occurs if $(\sigma L + R)$ is negative, or if $Z(\sigma) < 0$.

Let us now use our new knowledge of the forced response to find the complete response of a simple circuit. A series RC circuit including a switch which closes at $t = 0$ is shown in Fig. 13-3a. An exponential forcing function is applied, and the complete response

$$i(t) = i_n(t) + i_f(t)$$

is desired. The forced response may be specified exactly,

$$I = \frac{30}{3 - 2\frac{2}{3}} = -6$$

and, therefore,

$$i_f(t) = -6\epsilon^{-3t}$$

The natural response is characterized by the time constant of the RC circuit,

$$i_n(t) = A\epsilon^{-8t}$$

and the complete response is

$$i = A\epsilon^{-8t} - 6\epsilon^{-3t}$$

Since the initial value of the current is obviously 10 amp, we obtain the final result

$$i = 16\epsilon^{-8t} - 6\epsilon^{-3t}$$

This response is sketched in Fig. 13-3b. Again it should be noted how the natural response serves to connect smoothly the required initial value with the required forced response. After about one-third of a second, the natural response has a negligible amplitude, and the complete response is essentially equal to the forced response. As a matter of fact, the forced response might be determined

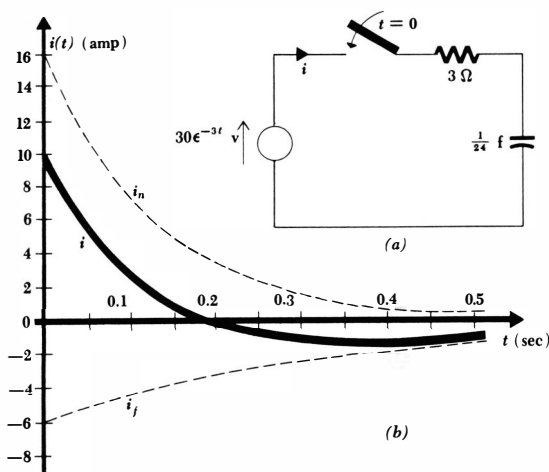

Fig. 13-3 (a) A series RC circuit which is excited by an exponential forcing function. (b) The complete current response of this circuit.

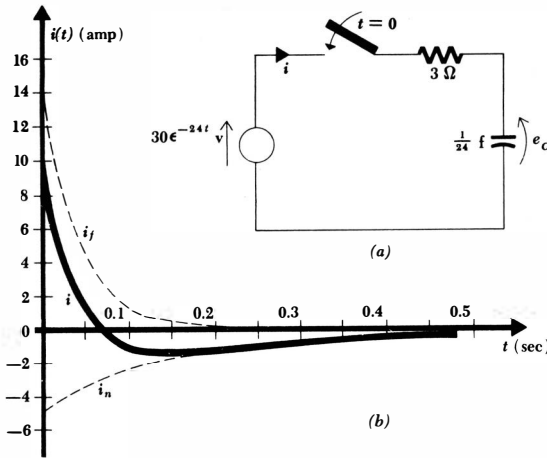

Fig. 13-4 (a) The neper frequency of the exponential source in the circuit of Fig. 13-3a is changed to $\sigma = -24$. (b) The resultant current response exhibits a natural response which overwhelms the forced response.

experimentally by closing the switch, waiting several time constants (about $\frac{1}{3}$ sec) for the natural response to disappear, and then observing or recording the response.

The question arises: Can the time constant be sufficiently large that the natural response decays so slowly that it obscures the forced response? It can. Suppose that we change the neper frequency of the forcing function and now apply $30e^{-24t}$, as shown in Fig. 13-4a. The forced response is now

$$i_f = 15e^{-24t}$$

and the natural response has the form

$$i_n = Ae^{-8t}$$

as before. The complete response is determined by again realizing that $i(0)$ is 10 amp,

$$i = -5e^{-8t} + 15e^{-24t}$$

After about $\frac{1}{8}$ sec, the forced response now has a negligible amplitude, as is apparent in the sketch of Fig. 13-4b. No amount of waiting will enable us

Fig. 13-5 (a) See Drill Prob. 13-1. (b) See Drill Prob. 13-2.

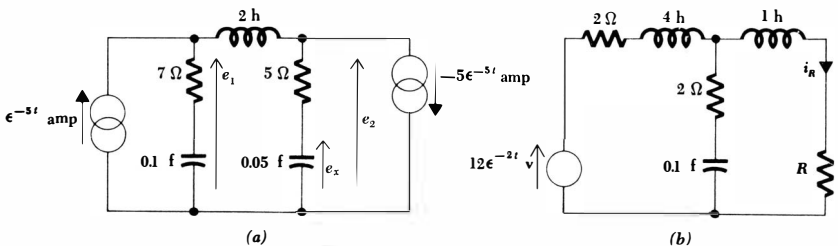

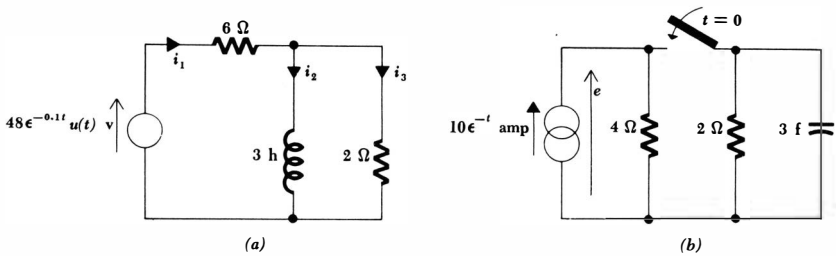

Fig. 13-6 (a) See Drill Prob. 13-3. (b) See Drill Prob. 13-4.

to obtain an experimental waveform which represents the forced response. There is a way out of our difficulties, however; we may provide the proper initial voltage across the capacitor to eliminate the natural response completely. In this circuit, we may cause A to be zero if we can force the initial current to be 15 amp. This initial current will flow if the initial value of e_c (as indicated in Fig. 13-4a) is -15 volts. We might think of the capacitor as being in parallel with a 15-volt battery which is removed at some time prior to $t = 0$. The *complete* response would then be

$$i = 15e^{-24t}$$

The initial capacitor voltage might also be provided more exotically by placing the voltage-step function $15u(t)$ volts in series with the capacitor or the impulse source $0.625\delta(t)$ amp in parallel with the source; the proper polarity must be selected.

The natural response may always be eliminated completely by a judicious selection of initial conditions.

Drill Problems

13-1 In the circuit shown in Fig. 13-5a, find the time-domain forced response: (a) e_1 ; (b) e_2 ; (c) e_x .

Ans. $-20e^{-5t}$ volts; $5e^{-5t}$ volts; $5e^{-5t}$ volts

13-2 Replace the portion of the circuit of Fig. 13-5b which is to the left of R by its Thévenin equivalent. (a) What value of R will cause i_R to be $-5e^{-2t}$ amp? (b) What value of R will cause i_R to be $5e^{-2t}$ amp? (c) What value of R will cause i_R to have a maximum amplitude?

Ans. 3.2 ohms; 4.0 ohms; 4.8 ohms

13-3 In the circuit shown in Fig. 13-6a, find the complete response: (a) $i_1(t)$; (b) $i_2(t)$; (c) $i_3(t)$.

Ans. $(7.5e^{-0.5t} - 1.5e^{-0.1t})u(t)$ amp
 $(-10e^{-0.5t} + 10e^{-0.1t})u(t)$ amp
 $(-2.5e^{-0.5t} + 8.5e^{-0.1t})u(t)$ amp

13-4 In the circuit shown in Fig. 13-6b, find $e(t)$ at: (a) $t = 0^-$; (b) $t = 0^+$; (c) $t = 2$ sec.

Ans. 0; 40; 2.09 volts

13-3 RESPONSE AS A FUNCTION OF σ

When an exponential forcing function is applied at one point in a circuit and an exponential forced response is observed at another point in the circuit, it is apparent that the magnitude of the response is a function of the neper frequency σ of the forcing function. Again, this is a simpler phenomenon to investigate than it is for a sinusoidal forcing function; an exponential response is completely characterized by its amplitude (which may be positive or negative) and its neper frequency, while a sinusoidal response requires an amplitude, a phase angle, and a radian frequency for a complete description. Stated another way, the exponential response may be described by a single real number and a (neper) frequency, but a sinusoidal response must be described by a complex number and a (radian) frequency. Let us investigate the variation of the exponential forced response with frequency² and determine an easy way to obtain it and a clear way to present the result.

As an example, we may select a series RL circuit excited by the voltage $E_m e^{\sigma t}$. The current is obtained by working first in the frequency domain:

$$I = \frac{E_m}{R + \sigma L}$$

$$\text{or } I = \frac{E_m}{L} \frac{1}{\sigma + R/L} \quad (13-1)$$

and then transforming to the time domain:

$$i(t) = \frac{E_m}{R + \sigma L} e^{\sigma t} \quad (13-2)$$

The necessary information about the response, however, is all contained in the frequency-domain description (13-1). As the frequency σ varies, a qualitative description of the response is easily provided. When σ is a large negative number, corresponding to a rapidly decreasing exponential function, the current response (13-1) is negative and relatively small in amplitude; it is, of course, also a rapidly decreasing (in magnitude) exponential function. As σ increases, becoming a smaller negative number, the magnitude of the negative response increases. When σ is exactly equal to $-R/L$, the response is infinite. An infinite-magnitude response is termed a *pole*, and the frequency at which an infinite-magnitude response occurs is also termed a pole. From Eq. (13-1), the only pole of the response is that one at $\sigma = -R/L$.

As σ continues to increase, the next noteworthy point occurs when $\sigma = 0$.

² When no opportunity for confusion exists, we may shorten "neper frequency" to "frequency."

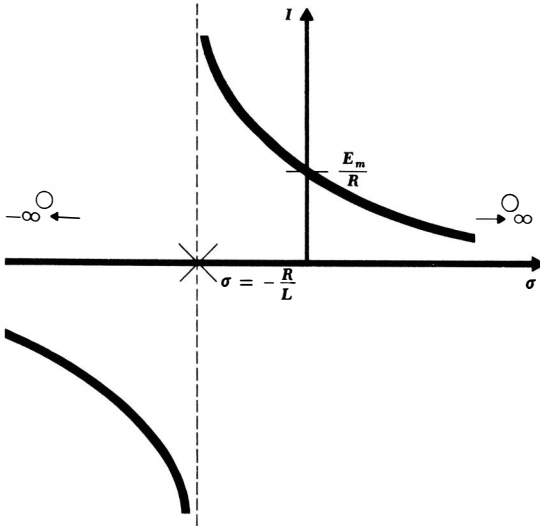

Fig. 13-7 A plot of current I versus frequency σ for a series RL circuit excited by an exponential voltage forcing function. The only pole is located at $\sigma = -R/L$; the zero occurs at $\sigma = \pm\infty$.

Since $e = E_m$, we are now faced with the d-c case, and the response is obviously E_m/R , which agrees with the response indicated by Eq. (13-1). Positive values of σ must all provide positive amplitude responses, the larger amplitudes arising when σ is smaller. Finally, an infinite value of σ provides a zero-amplitude response. A zero-amplitude response (and the frequency at which a zero-amplitude response is obtained) is called a *zero*, and it is evident that $\sigma = \pm\infty$ is a zero.³ Poles and zeros are termed *critical frequencies*.

This information may be presented quite easily by plotting I , the current amplitude, as a function of σ , as shown in Fig. 13-7. The information provided in the graph is frequency-domain information. All poles at finite frequencies are indicated by *crosses* on the σ axis, and all zeros at finite frequencies are identified by small *circles* on the frequency axis. Poles or zeros at $\sigma = \pm\infty$ should be indicated by an arrow near the axis, as shown in Fig. 13-7. The actual drawing of the graph is made easier by adding broken lines as asymptotes at each pole location.

Let us now turn our attention to the two critical frequencies of this response. The only finite critical frequency is the pole at $\sigma = -R/L$. It is worth our while to determine why an infinite response is obtained when the circuit is excited at this frequency by the voltage

$$e = E_m e^{-Rt/L} \tag{13-3}$$

The forcing function (13-3) has a familiar form; it has all the characteristics of the natural response. As a matter of fact, if we reduce the amplitude of this

³ It is customary to consider plus infinity and minus infinity as being the same point. The response at very large positive and negative values of σ is not the same, however.

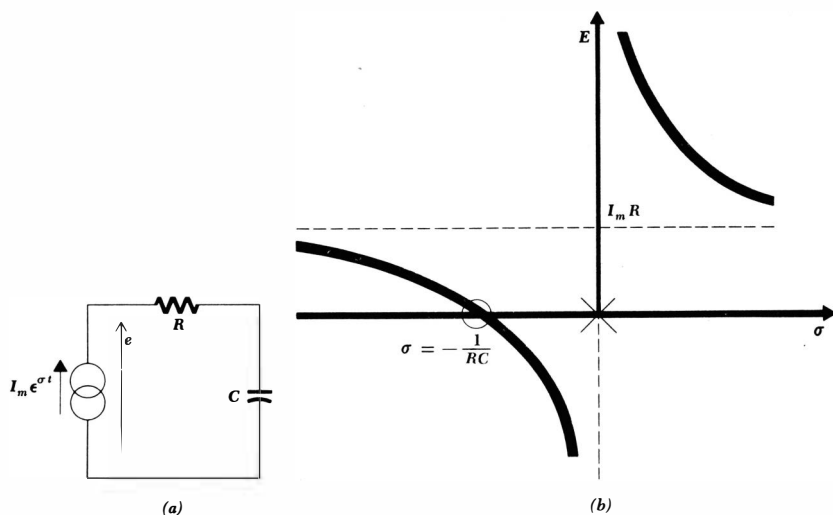

Fig. 13-8 (a) A series RC circuit excited by an exponential current source. (b) The voltage response possesses a pole at $\sigma = 0$ and a zero at $\sigma = -1/RC$.

forcing function to zero, thus “exciting” the circuit by a short circuit, then the current

$$i = I_0 e^{-Rt/L} \quad (13-4)$$

would flow if an initial current I_0 is assumed. Although this is a natural response, it is informative to interpret the result as a forced response; we find that a zero-amplitude forcing function then produces a non-zero-amplitude response. Since the circuit is linear, a non-zero-amplitude forcing function must produce an infinite response.

We shall find that this result is quite general; when any circuit is excited at a frequency which is a pole of the response, then an infinite response must result; the frequencies of the poles and zeros are directly related to the natural response of the circuit. This relationship will be seen to arise in several examples discussed in this chapter, but we shall not discuss it thoroughly until the following chapter.

As a second example, let us consider the circuit drawn in Fig. 13-8a. The exponential current source

$$i = I_m e^{\sigma t}$$

is applied to a series RC circuit. The voltage across the source is given by

$$E = IZ(\sigma) = I_m \left(R + \frac{1}{\sigma C} \right)$$

$$\text{or} \quad E = I_m R \frac{\sigma + 1/RC}{\sigma} \quad (13-5)$$

381 The Exponential Forcing Function

This last form of the voltage response, written as a constant times the ratio of factors having the form $(\sigma + \sigma_1)$, is obviously well suited for the quick determination of the poles and zeros of the response. The voltage response indicates a pole at $\sigma = 0$ and a zero at $\sigma = -1/RC$; infinite frequency is not a critical frequency. The response E is plotted as a function of frequency in Fig. 13-8b. The reason for the pole at direct current may again be explained on physical grounds; if $I_m = 0$, the current source is effectively an open circuit and the response is the constant initial capacitor voltage; a nonzero I_m must therefore produce an infinite voltage response. In other words, if a constant current has been applied to the network forever, then the capacitor must have charged to an infinite voltage. All poles are of course a consequence of the ideal models we are assuming to represent the physical devices; a real capacitor would only permit the voltage to increase to some large value before its dielectric broke down.

A more complicated response curve is obtained for the circuit shown in Fig. 13-9a. The current is easily found:

$$I = \frac{100}{6 + \sigma + 5/\sigma}$$

or

$$I = 100 \frac{\sigma}{(\sigma + 1)(\sigma + 5)} \quad (13-6)$$

Fig. 13-9 (a) A series RLC circuit is driven by an exponential forcing function. (b) The resultant current-response curve shows zeros at $\sigma = 0$ and $\sigma = \pm\infty$, and poles at $\sigma = -5$ and -1 .

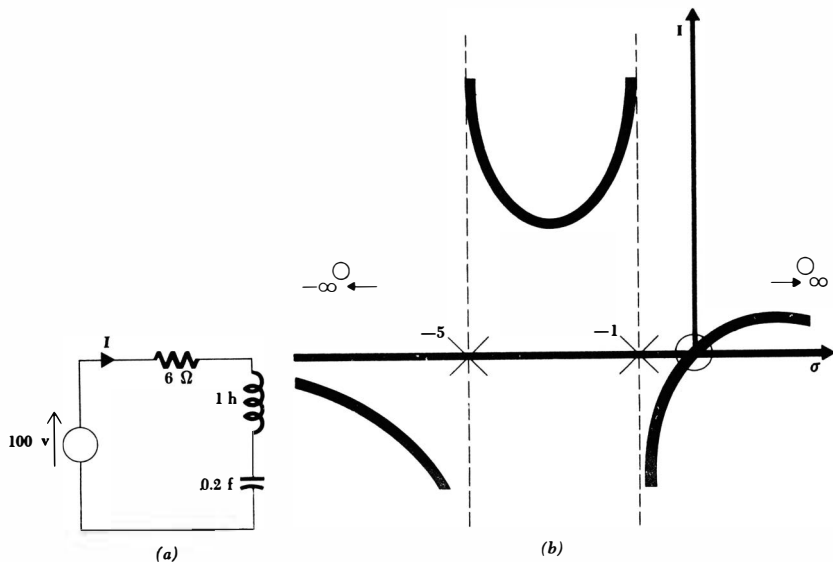

The response curve is most easily obtained by first indicating the locations of all poles and zeros on the σ axis, placing vertical asymptotes at the poles, and then determining the algebraic sign of the response in the intervals between the critical frequencies. When this is done, we find that a minimum of the response must exist between the two poles, and a maximum must be present at some frequency greater than zero. By differentiation, the locations of this minimum and maximum may be determined as $\sigma = -\sqrt{5}$ and $\sigma = \sqrt{5}$, respectively. The value of the response at the minimum turns out to be 0.655 and that of the maximum, 0.0955. To emphasize the relationship between the time domain and frequency domain once again, the response at $\sigma = -3$ is found from Eq. (13-6) to be 75 amp; hence, excitation of the network by the forcing function $e(t) = 100e^{-3t}$ produces the forced current response $i(t) = 75e^{-3t}$.

The two poles may again be identified as the natural resonant frequencies of the circuit. That is, the transient response of an *RLC* circuit has the form

$$i_n = A_1 e^{s_1 t} + A_2 e^{s_2 t}$$

where s_1 and s_2 are given by

$$\begin{aligned} s_{1,2} &= -\frac{R}{2L} \pm \sqrt{\left(\frac{R}{2L}\right)^2 - \frac{1}{LC}} \\ &= -1 \text{ and } -5 \end{aligned}$$

Thus, a zero-amplitude forcing function at either of these two frequencies $\sigma = -1$ or $\sigma = -5$ is associated with a finite amplitude response, the natural response of the circuit; a non-zero-amplitude forcing function provides an infinite response or a pole.

Drill Problems

13-5 If I_s represents an exponential forcing function, find all critical frequencies of the voltage response E of the circuit shown in Fig. 13-10a, and sketch E versus σ .

Ans. -1.229 nepers/sec; -0.4 nepers/sec; -0.271 nepers/sec; 0 nepers/sec

13-6 Assume exponential excitation of the circuit shown in Fig. 13-10b, find all critical frequencies of the response I_L , and sketch I_L versus σ .

Ans. -10 nepers/sec; $-1\frac{1}{2}$ nepers/sec; 0 nepers/sec; $\pm\infty$ nepers/sec

13-7 A two-terminal network is driven by the source $80e^{\sigma t}$ volts. The current through the source is the response, and it has a zero at $\sigma = -2$ and poles at $\sigma = -1$ and -3 . When $\sigma = 0$, $I = 8$ amp. Write an expression for $I(\sigma)$ and evaluate it at: (a) $\sigma = -4$; (b) $\sigma = -2.5$; (c) $\sigma = \pm\infty$.

Ans. -8 amp; 0 amp; 8 amp

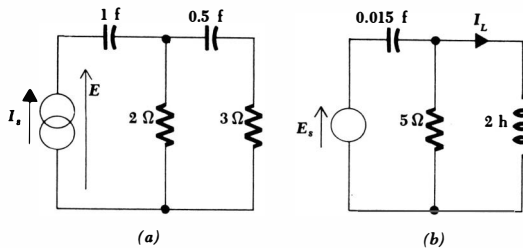

Fig. 13-10 (a) See Drill Prob. 13-5. (b) See Drill Prob. 13-6.

13-8 The impedance $Z(\sigma)$ may be viewed as a response by considering it as the voltage produced by a current of unit amplitude. Assume that $Z(\sigma)$ has a pole at $\sigma = -5$ and a zero at $\sigma = -1$; the impedance at infinite frequency is 20 ohms. Find: (a) $Z(0)$; (b) $Z(-3)$; (c) $Z(-6)$.

Ans. -20 ohms; 4 ohms; 100 ohms

13-4 RESPONSE AS A FUNCTION OF ω

Although this chapter is supposedly devoted to the exponential forcing function, we shall find that we can obtain a better appreciation of the interrelationships between the exponential, the sinusoidal, and the damped sinusoidal forcing functions of the next chapter if we carry our discussion of frequency response over into the realm of the radian frequency ω . We have actually done very little work with the response of a sinusoidally excited circuit as a function of frequency.⁴ Our neglect has not been caused by any lack of importance. With the possible exception of the 60-cps power area in which frequency is a constant and the load is the variable, sinusoidal frequency response is extremely important in almost every branch of electrical engineering, as well as in the theory of mechanical vibrations. We have simply had other subjects which were more conveniently studied first. Now we shall consider the methods of obtaining and presenting the response of a circuit with sinusoidal excitation as a function of the radian frequency ω .

Let us suppose that we have a circuit which is excited by a single source $E_s = E_s/\theta$. This phasor voltage may also be transformed into the time-domain source voltage $E_s \cos(\omega t + \theta)$. Somewhere in the circuit exists the desired response, the current I . As we know, this phasor response is a complex number, and its value cannot be specified in general without the use of two quantities: either a real part and an imaginary part or a magnitude and a phase angle. The latter pair of quantities is more easily determined experimentally, and it is the information which we shall obtain analytically as a function of frequency. The data may be presented as two curves, the magnitude of the response as a function of ω and the phase angle of the response as a function of ω . We often normalize the curves by plotting the magnitude of the current-voltage ratio and

⁴The term "frequency" may be used for "radian frequency" when the meaning is clear.

the phase angle of the current-voltage ratio versus ω . It is evident that an alternative description of the resultant curves is the magnitude and phase angle of an admittance as a function of frequency. A normalized voltage response may be similarly presented as the magnitude and phase angle of an impedance versus ω . Other possibilities are voltage-voltage ratios (voltage gains) or current-current ratios (current gains). Let us consider the details of this process by thoroughly discussing several examples.

For the first example, let us select the series RL circuit used as the initial example in discussing the response to an exponential forcing function as a function of the real part of the complex frequency σ . The phasor voltage \mathbf{E}_s is therefore applied to this simple circuit, and the phasor current \mathbf{I} is selected as the desired response. We are dealing with the forced response only, and the familiar phasor methods enable the current to be obtained:

$$\mathbf{I} = \frac{\mathbf{E}_s}{R + j\omega L}$$

Let us immediately express this result in normalized form as a ratio of current to voltage, that is, as an input admittance:

$$\mathbf{Y} = \frac{\mathbf{I}}{\mathbf{E}_s}$$

$$\text{or } \mathbf{Y} = \frac{1}{R + j\omega L} \quad (13-7)$$

If we like, we may consider the admittance as the current produced by a source voltage $1/\underline{0}^\circ$ volt. The magnitude of the response is

$$|\mathbf{Y}| = \frac{1}{\sqrt{R^2 + \omega^2 L^2}} \quad (13-8)$$

while the angle of the response is found to be

$$\text{ang } \mathbf{Y} = -\tan^{-1} \frac{\omega L}{R} \quad (13-9)$$

Equations (13-8) and (13-9) are the analytical expressions for the magnitude and phase angle of the response as a function of ω ; we now desire to present this same information graphically.

We shall first consider the magnitude curve. The first important factor to note is that we are plotting the absolute magnitude of some quantity versus ω , and the entire curve must therefore lie *above* the ω axis. Once this characteristic is firmly established, we should look for the poles and zeros of the response. In the form in which Eq. (13-8) is presented, this information is slightly more difficult to obtain than it is for the exponential case; the introduction of the complex-frequency concept in the following chapter will simplify the procedure. However, for the simple circuit and simple expression which we have, the only real value of ω at which either an infinite-amplitude or a zero-amplitude response

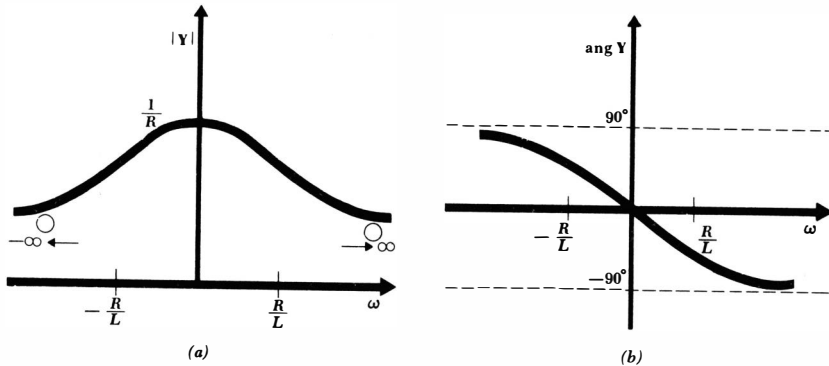

Fig. 13-11 (a) The magnitude of Y and (b) the angle of Y are plotted as functions of ω for a series RL circuit with sinusoidal excitation.

is obtained is infinite frequency, which represents a zero. No pole exists. The response curve is constructed by noting that the value of the response at zero frequency is $1/R$, that the initial slope is zero, and that the response decreases as frequency increases; the graph of the magnitude of the response as a function of ω is shown in Fig. 13-11a.

For the sake of generality and completeness, the response is shown for both positive and negative values of frequency; the symmetry results from the fact that Eq. (13-8) indicates that $|Y|$ has the same value when ω is replaced by $(-\omega)$. The physical interpretation of a negative radian frequency, such as $\omega = -100$, depends on the time-domain function, and it may always be obtained by inspection of the time-domain expression. Suppose, for example, that we consider the voltage $e(t) = 50 \cos(\omega t + 30^\circ)$. At $\omega = 100$, the voltage is $e(t) = 50 \cos(100t + 30^\circ)$, while at $\omega = -100$, $e(t) = 50 \cos(-100t + 30^\circ)$ or $50 \cos(100t - 30^\circ)$. Any sinusoidal response may be treated in a similar manner.

The second part of the response, the phase angle of Y versus ω , is an inverse tangent function. The tangent function itself is quite familiar, and we should have no difficulty in turning that curve on its side; asymptotes of plus and minus 90° are helpful. The response curve is shown in Fig. 13-11b. The points at which $\omega = \pm R/L$ are marked on both the magnitude and phase curves. At these frequencies the magnitude is 0.707 of the maximum magnitude at zero frequency and the phase angle has a magnitude of 45° . It is not very strange that $\omega = R/L$ is identified as a *half-power frequency*.

As a second example, let us select a parallel LC circuit driven by a sinusoidal current source, as illustrated in Fig. 13-12a. The voltage response E is easily obtained:

$$E = I_s \frac{(j\omega L)(1/j\omega C)}{j\omega L - j(1/\omega C)}$$

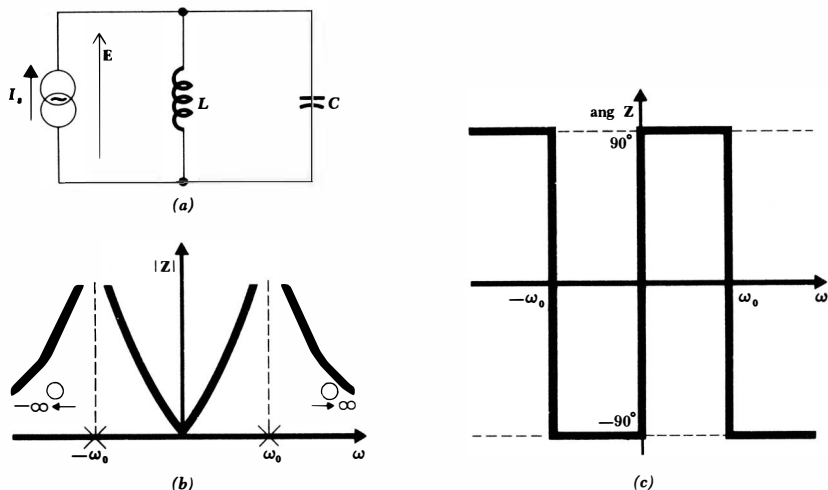

Fig. 13-12 (a) A sinusoidally excited parallel LC circuit. (b) The magnitude of the input impedance and (c) the phase angle of the input impedance are plotted as functions of ω to the same ω scale.

and it may be expressed as an input impedance

$$Z = \frac{E}{I_s} = \frac{L/C}{j(\omega L - 1/\omega C)}$$

$$\text{or } Z = -j \frac{1}{C} \frac{\omega}{\omega^2 - 1/LC} \quad (13-10)$$

The magnitude of the impedance may be written in a form which displays the poles and zeros clearly:

$$|Z| = \frac{1}{C} \frac{|\omega|}{|(\omega - \omega_0)(\omega + \omega_0)|} \quad (13-11)$$

where

$$\omega_0 = \frac{1}{\sqrt{LC}}$$

The use of the absolute-magnitude signs is necessary since one of the factors may be negative for a certain range of positive frequencies, and the other two factors may be negative when ω is negative. Two poles, at $\omega = \pm\omega_0$, and two zeros, at $\omega = 0$ and $\pm\infty$, are apparent. After constructing asymptotes at the locations of the poles, the magnitude versus ω response curve shown in Fig. 13-12b is quickly constructed. The slope at the origin is *not* zero.

An inspection of Eq. (13-10) shows that the phase angle of the input impedance must be either $+90^\circ$ or -90° ; no other values are possible, as must apparently be the case for any circuit composed entirely of inductors and capaci-

tors. An analytical expression for $\text{ang } Z$ would therefore consist of a series of statements that the angle is $+90^\circ$ or -90° in certain frequency ranges. It is simpler merely to present the information graphically, as shown in Fig. 13-12c. Although this curve is a simple collection of vertical and horizontal straight lines, errors are often made in its construction, and it is a good idea to make certain that it can be drawn directly from an inspection of Eq. (13-10).

The two poles of the impedance may once again be related to the natural response of the circuit. If the amplitude of the current source is reduced to zero, it is effectively an open circuit, and the natural response $e_n(t)$ may be written in terms of s_1 and s_2 as before:

$$e_n(t) = A_1 e^{s_1 t} + A_2 e^{s_2 t}$$

where, from the results obtained in Chap. 8,

$$s_{1,2} = \pm j \frac{1}{\sqrt{LC}} \quad \text{or} \quad s_{1,2} = \pm j\omega_0$$

We shall meet this response form in Sec. 14-2, but we may conclude now that the natural response occurs at the radian frequency $\omega = \omega_0$. Initial conditions determine A_1 and A_2 , and the magnitude and phase of the response are found from them. In summary, a zero-amplitude current source is thus associated with non-zero-amplitude responses at the frequencies of the poles; a non-zero-amplitude source must therefore cause an infinite response at these two frequencies. They are thus poles.

After the complex-frequency plane is introduced in the following chapter, we shall see that the response plots we have been making in this section and in the previous section as functions of σ or ω are but two different aspects of the same problem.

Drill Problems

13-9 Find all the critical frequencies and sketch the magnitude and phase angle of the input admittance versus ω for the networks shown in Fig. 13-13a, b, and c.

Ans. -3 radians/sec, -2 radians/sec, 0 radians/sec, $+2$ radians/sec, $+3$ radians/sec, $\pm \infty$ radians/sec

Fig. 13-13 See Drill Probs. 13-9 and 13-10.

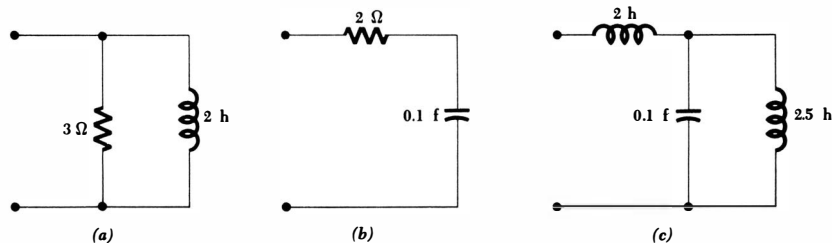

13-10 Repeat Drill Prob. 13-9 for the input impedance.

Ans. -3 radians/sec, -2 radians/sec, 0 radians/sec, $+2$ radians/sec, $+3$ radians/sec, $\pm \infty$ radians/sec

13-11 In the circuit shown in Fig. 13-14, consider the voltage gain E_2/E_1 as the normalized response. Find all critical frequencies of this response and sketch the magnitude and phase angle of the response as functions of ω .

Ans. -1.618 radians/sec, -0.618 radian/sec, 0.618 radian/sec, 1.618 radians/sec, $\pm \infty$ radians/sec

Problems

- ◆1 For each of the one-port networks shown in Fig. 13-15a, b, and c: (a) find the general expression for $Z(\sigma)$ and evaluate at $\sigma = -3$; (b) find the general expression for $Z(j\omega)$ and evaluate at $\omega = 2$.
- ◆2 Associate each of the voltage sources in the circuit of Fig. 13-1b with a suitable series impedance and then transform to a current source. Use nodal methods to obtain the steady-state current through the 4-ohm resistor.
- 3 Find the current requested in Prob. 2 by applying Thévenin's theorem to the network faced by the 4-ohm resistor.

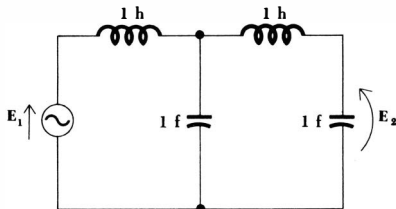
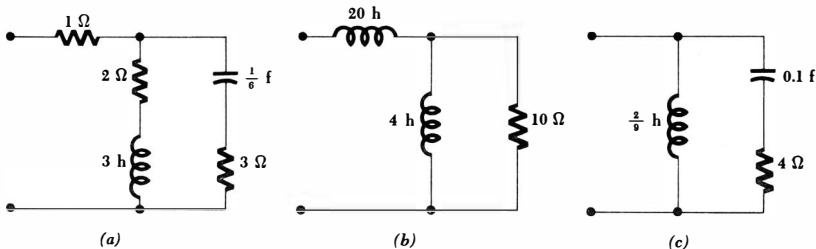

Fig. 13-14 See Drill Prob. 13-11.

Fig. 13-15 See Prob. 1.



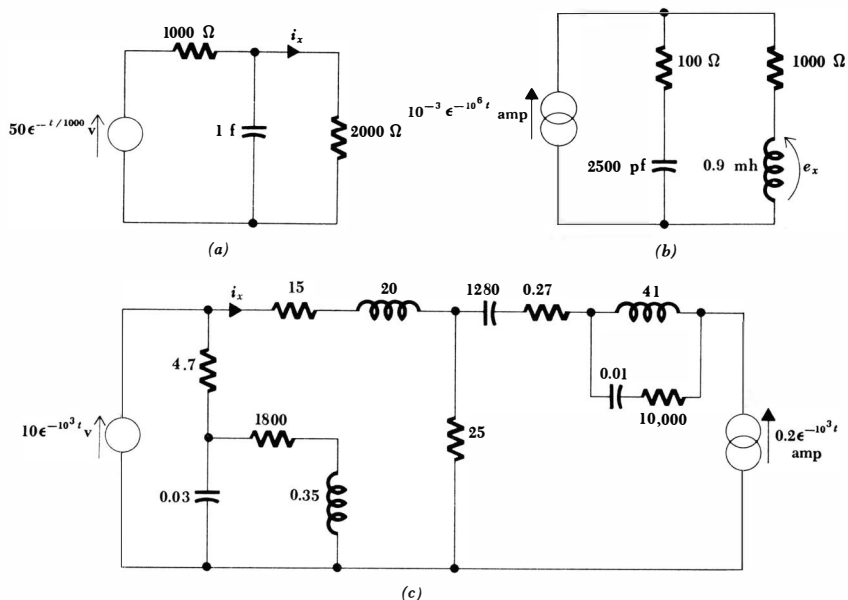

Fig. 13-16 (a) See Prob. 4. (b) See Prob. 5. (c) See Prob. 6.

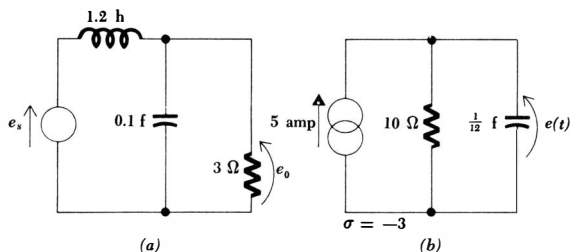

Fig. 13-17 (a) See Prob. 7. (b) See Prob. 8.

- 4 Find $i_x(t)$ in the circuit shown in Fig. 13-16a.
- 5 Find $e_x(t)$ in the circuit shown in Fig. 13-16b.
- 6 Find $i_x(t)$ in the circuit shown in Fig. 13-16c. The values of the circuit elements are given in ohms, millihenrys, and microfarads, and the problem only looks hard.
- 7 In the circuit shown in Fig. 13-17a, $e_s(t) = 4e^{-5t}$ volts. Find the steady-state output voltage $e_0(t)$.
- 8 In the circuit shown in Fig. 13-17b, find $e(t)$ at $t = -0.5$ and $t = 0.5$ sec.
- 9 The Thévenin equivalent of a circuit in the exponential steady state consists of an open-circuit voltage of 10 volts amplitude at a frequency $\sigma = -4$ in series with an impedance $Z(\sigma) = -10$ ohms. Using two resistors,

one capacitor, and a 20-volt exponential source, synthesize a circuit which will offer the above Thévenin equivalent. This problem does not have a unique answer.

- 10 An ideal voltage source e_s is in series with a 10-ohm resistor, a 2-henry inductor, and a 0.4-farad capacitor. Find the forced current response if e_s is:
 ♦(a) $5\epsilon^{-2t}$ volts; (b) $5\epsilon^{-2t} + 5\epsilon^{2t}$ volts; (c) $10 \cosh 2t$ volts.
- 11 Find $i(t)$ in the circuit shown in Fig. 13-18a.
- ♦12 The two sources in the circuit shown in Fig. 13-18b are: $e_s = 4\epsilon^{-3t}$ volts, $i_s = 8 \cos 5t$ amp. Find the steady-state current $i(t)$.

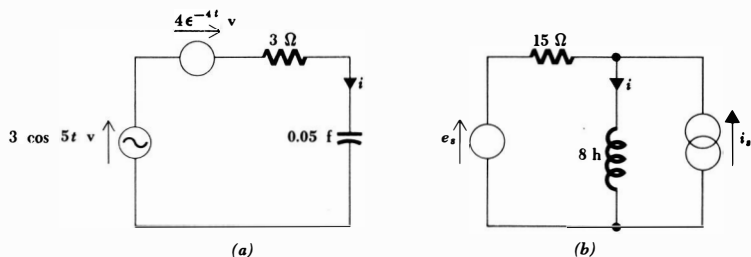

Fig. 13-18 (a) See Prob. 11. (b) See Prob. 12.

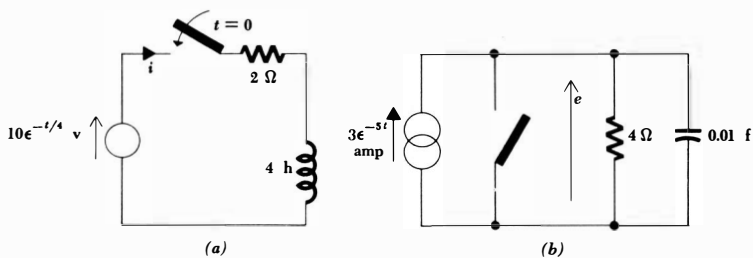
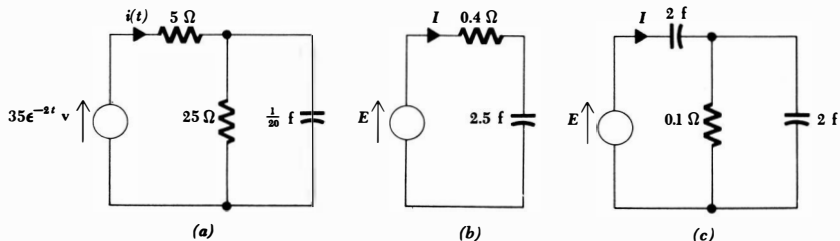

Fig. 13-19 (a) See Prob. 13. (b) See Prob. 14.

Fig. 13-20 (a) See Prob. 15. (b) and (c) See Prob. 16.



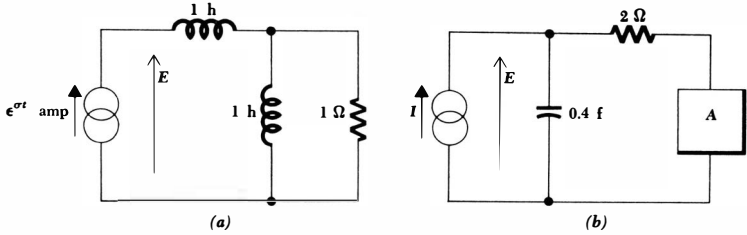

Fig. 13-21 (a) See Prob. 17. (b) See Prob. 18.

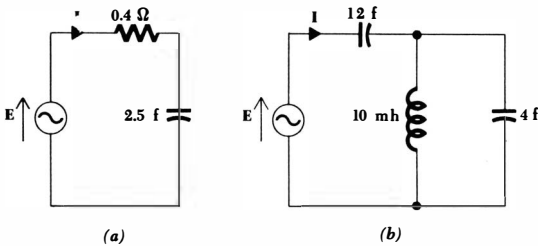

Fig. 13-22 See Prob. 21.

- 13 Find $i(t)$ for $t < 0$ and $t > 0$ in the circuit shown in Fig. 13-19a.
- ◆14 With reference to the circuit of Fig. 13-19b: (a) The switch has been open for a long time (but t is *not* infinite); find $e(t)$. (b) The switch is now closed and left closed for a long time. At $t = 0$ it is opened. Find $e(t)$ for $t > 0$.
- 15 With reference to the circuit shown in Fig. 13-20a: (a) The voltage source has been connected to the circuit for a very long time (but t is *not* infinite); find $i(t)$. (b) The voltage source is connected to the network at $t = 0$. If the capacitor is initially uncharged, find $i(t)$, $t > 0$.
- 16 Sketch I/E versus σ in the range $-10 < \sigma < 10$ for the circuit shown in: (a) Fig. 13-20b; (b) Fig. 13-20c.
- 17 Sketch E as a function of σ for the circuit shown in Fig. 13-21a. State the location of all poles and zeros.
- 18 For the circuit shown in Fig. 13-21b, locate all the critical frequencies of the response E/I and plot E/I versus σ if network A is: (a) a 1-ohm resistor; (b) a 1-farad capacitor; (c) a 0.3-henry inductor.
- ◆19 What are the characteristics of a general impedance $Z(\sigma)$ if $Z(\sigma)$ has: (a) a zero at $\sigma = 0$? (b) a pole at $\sigma = 0$? (c) a zero at $\sigma = \infty$? (d) a pole at $\sigma = \infty$?
- ◆20 An impedance $Z(\sigma)$ has one finite critical frequency, a pole at $\sigma = -3$. If $Z(0) = 9$ ohms, determine $Z(\sigma)$ at: (a) $\sigma = -3$; (b) $\sigma = -1$; (c) $\sigma = 1$; (d) $\sigma = \pm \infty$.
- 21 Sketch the magnitude and phase of the input admittance of the networks shown in Fig. 13-22a and b as functions of ω in the range $-10 < \omega < 10$.

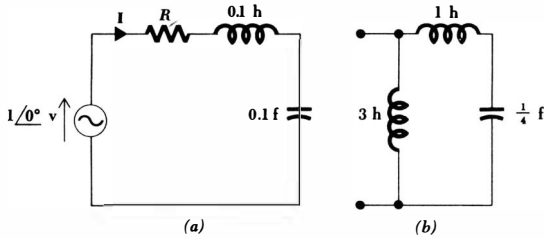

Fig. 13-23 (a) See Prob. 22. (b) See Prob. 24.

- 22 In the circuit shown in Fig. 13-23a, sketch $|\mathbf{I}|$ versus ω if: (a) $R = 0$; (b) $R = 1$ ohm; (c) $R = 2$ ohms.
- 23 What are the characteristics of a general impedance $\mathbf{Z}(j\omega)$ if $\mathbf{Z}(j\omega)$ has: (a) a zero at $\omega = 0$? (b) a pole at $\omega = 0$? (c) a zero at $\omega = \infty$? (d) a pole at $\omega = \infty$?
- 24 Sketch the magnitude and phase angle of the input impedance of the network shown in Fig. 13-23b as a function of ω .
- 25 A resistor R is in series with the parallel combination of another resistor R and an inductor L . (a) Write the analytical expression for the magnitude of the input impedance. (b) Sketch the magnitude of the input impedance versus ω if $R = 1$ ohm and $L = 1$ henry.
- 26 A 1-henry inductor and a 1-farad capacitor are in parallel. A 1-ohm resistor is in series with the parallel combination. This network is excited by a source $1\angle 0^\circ$ volt. Sketch $|\mathbf{I}|$ and $\text{ang } \mathbf{I}$ versus ω , if \mathbf{I} is the source current.

Chapter 14 Complex Frequency

14-1 INTRODUCTION

The forcing functions which we may now apply to an electrical network, with every hope of finding the forced response successfully, include the constant (direct current), the sinusoid, and the exponential. We should perhaps suspect that these three functions have some basic similarity. For example, almost all the methods we developed for sinusoidal analysis in the frequency domain we have found to be still suitable for the exponential function in its frequency domain. The similarity in the methods of analysis arises from the fact that these three functions are all special cases of the exponentially damped sinusoid, the most general type of function to which the basic frequency-domain methods may be applied.¹

Let us assume an exponentially damped sinusoidal function to represent, say, a voltage

$$e(t) = E_m e^{\sigma t} \cos(\omega t + \theta) \quad (14-1)$$

Although we refer to this function as being “damped,” it is possible that the function may increase if σ is positive; the more practical case is that of the damped function.

We may first construct a constant voltage by letting both σ and ω be zero,

$$e(t) = E_m \cos \theta = E_0$$

If we set only σ equal to zero, then we obtain a general sinusoidal voltage

$$e(t) = E_m \cos(\omega t + \theta)$$

And if $\omega = 0$, we have the exponential voltage

$$e(t) = E_m \cos \theta e^{\sigma t} = E_0 e^{\sigma t}$$

¹ The basic methods are extended in Chap. 20 to cover still other functions.

Thus, the exponentially varying sinusoid (14-1) may be used to represent any of the three types of functions we have previously considered; we need only set $\sigma = 0$, $\omega = 0$, or both $\sigma = 0$ and $\omega = 0$.

The response of a network to this general function (14-1) is found very simply by using a method almost identical with that used for the sinusoidal and exponential forcing functions; we shall discuss the method in Sec. 14-4. When we are able to find the response to this damped sinusoid, we should realize that we shall also have found the response to a d-c voltage, an exponential voltage, and a sinusoidal voltage. Now let us see how we may consider σ and ω as the real and imaginary parts of a complex frequency.

14-2 COMPLEX FREQUENCY

Let us first provide ourselves with a purely mathematical definition of complex frequency and then gradually develop a physical interpretation in the next few sections. We shall say that any function which may be written in the form

$$f(t) = \mathbf{K}e^{st} \quad (14-2)$$

where \mathbf{K} and s are complex constants (independent of time), is characterized by the *complex frequency* s . The complex frequency s is therefore simply the factor which multiplies t in this complex exponential representation. Until we are able to determine the complex frequency of a given function by inspection, it is necessary to write the function in the form of Eq. (14-2).

We may apply this definition first to the more familiar forcing functions. For example, a constant voltage

$$e(t) = E_0$$

may be written in the form

$$e(t) = E_0 e^{(0)t}$$

The complex frequency of a d-c voltage or current is thus zero; $s = 0$. The next simple case is the exponential function

$$e(t) = E_0 e^{\sigma t}$$

which is already in the required form; the complex frequency of this voltage is therefore σ ; $s = \sigma + j0$. Finally, let us consider a sinusoidal voltage, one which may provide a slight surprise. Given

$$e(t) = E_m \cos(\omega t + \theta)$$

it is necessary to find an equivalent expression in terms of the complex exponential. From our past experience, we therefore use the identity we derived from Euler's formula,

$$\cos(\omega t + \theta) = \frac{1}{2}(e^{j(\omega t + \theta)} + e^{-j(\omega t + \theta)})$$

395 Complex Frequency

and obtain

$$e(t) = \frac{1}{2}E_m[e^{j(\omega t + \theta)} + e^{-j(\omega t + \theta)}]$$

or
$$e(t) = (\frac{1}{2}E_m e^{j\theta})e^{j\omega t} + (\frac{1}{2}E_m e^{-j\theta})e^{-j\omega t}$$

We have the *sum* of two complex exponentials, and *two* complex frequencies are therefore present, one for each term. The complex frequency of the first term is $s = s_1 = j\omega$ and that of the second term is $s = s_2 = -j\omega$. These two values of s are conjugates, or $s_2 = s_1^*$, and the two values of \mathbf{K} are also conjugates. The entire first term and the entire second term are therefore conjugates, which we should expect inasmuch as their sum must be a real quantity.

Now let us determine the complex frequency or frequencies associated with the exponentially damped sinusoidal function (14-1). We again use Euler's formula to obtain a complex exponential representation:

$$\begin{aligned} e(t) &= E_m e^{\sigma t} \cos(\omega t + \theta) \\ &= \frac{1}{2}E_m e^{\sigma t} (e^{j(\omega t + \theta)} + e^{-j(\omega t + \theta)}) \end{aligned}$$

and thus

$$e(t) = \frac{1}{2}E_m e^{j\theta} e^{(\sigma + j\omega)t} + \frac{1}{2}E_m e^{-j\theta} e^{(\sigma - j\omega)t}$$

We therefore find once again that a conjugate complex pair of frequencies is required to describe the exponentially damped sinusoid, $s_1 = \sigma + j\omega$, and $s_2 = s_1^* = \sigma - j\omega$. In general, neither σ nor ω is zero, and we see that the exponentially varying sinusoidal waveform is the general case; the constant, sinusoidal, and exponential waveforms are special cases.

As numerical illustrations, we should now recognize at sight the complex frequencies associated with these voltages:

$$\begin{array}{ll} e(t) = 100 & s = 0 \\ e(t) = 5e^{-2t} & s = -2 + j0 \\ e(t) = 2 \sin 500t & \begin{cases} s_1 = j500 \\ s_2 = s_1^* = -j500 \end{cases} \\ e(t) = 4e^{-3t} \sin(6t + 10^\circ) & \begin{cases} s_1 = -3 + j6 \\ s_2 = s_1^* = -3 - j6 \end{cases} \end{array}$$

The reverse type of example is also worth consideration. Given a complex frequency or a pair of conjugate complex frequencies, we must be able to identify the nature of the function with which they are associated. The most special case, $s = 0$, defines a constant or d-c function. With reference to the defining functional form (14-2), it is apparent that the constant \mathbf{K} must be real if the function is to be real.

Let us next consider real values of s . A positive real value, such as $s = 5 + j0$, identifies an exponentially increasing function $\mathbf{K}e^{5t}$, where again \mathbf{K} must be real if the function is to be a physical one. A negative real value for s , such as $s = -5 + j0$, refers to an exponentially decreasing function $\mathbf{K}e^{-5t}$.

A purely imaginary value of s , for example, $j10$, can never be associated with

a real quantity; the functional form is $\mathbf{K}\epsilon^{10t}$, which can also be written as $\mathbf{K}(\cos 10t + j \sin 10t)$, and obviously possesses both real and imaginary parts. Each part is sinusoidal in nature. In order to construct a real function, it is necessary to consider conjugate values of s , such as $s_{1,2} = \pm j10$, with which must be associated conjugate values of \mathbf{K} . Loosely speaking, however, we may identify either of the complex frequencies $s_1 = j10$ or $s_2 = -j10$ with a sinusoidal voltage at the radian frequency of 10 radians/sec. The presence of the conjugate complex frequency is understood. The amplitude and phase angle of the sinusoidal voltage will depend on the choice of \mathbf{K} for each of the two frequencies. Thus, selecting $s_1 = j10$ and $\mathbf{K}_1 = 6 - j8$, where $s_2 = s_1^*$ and $\mathbf{K}_2 = \mathbf{K}_1^*$, we obtain the real sinusoid $20 \cos(10t - 53.1^\circ)$.

In a similar manner, a general value for s , such as $3 - j5$, can be associated with a real quantity only if it is accompanied by its conjugate $3 + j5$. Speaking loosely again, we may think of either of these two conjugate frequencies as describing an exponentially increasing sinusoidal function $\epsilon^{3t} \cos 5t$; the specific amplitude and phase angle will again depend on the specific values of the conjugate complex \mathbf{K} 's.

By now we should have achieved some appreciation of the physical nature of the complex frequency s ; in general, it describes an exponentially varying sinusoid. The real part of s is associated with the exponential variation; if it is negative, the function decays; if positive, the function increases; and if it is zero, the sinusoidal amplitude is constant. The imaginary part of s describes the sinusoidal variation; it is specifically the radian frequency.

It is customary to call the real part of s , σ , and the imaginary part ω (*not* $j\omega$):

$$s = \sigma + j\omega \quad (14-3)$$

Our previous discussion of the waveform associated with the various values of s shows that σ may still be identified with the neper frequency of the previous chapter and that ω is still the radian frequency or angular frequency.

The radian frequency is sometimes referred to as the "real frequency," but this terminology can be very confusing when we find that we must then say that "the real frequency is the imaginary part of the complex frequency"! When we need to be specific, we shall call s the complex frequency, σ the neper frequency, ω the radian frequency, and f the cyclic frequency; when no confusion seems likely, it is permissible to use "frequency" to refer to any of these four quantities. The neper frequency is measured in nepers per second, radian frequency is measured in radians per second, and complex frequency s is measured in units which are variously termed complex nepers per second or complex radians per second. Perhaps it is sufficient that we recognize the dimensions of σ , ω , f , and s as $[T^{-1}]$.

Drill Problems

14-1 Determine all the complex frequencies associated with the current waveform: (a) $i(t) = 12(1 - \epsilon^{-0.1t})$; (b) $i(t) = 3 \sin(2\pi 60t - \pi/3)$; (c) $i(t) = 10\epsilon^{-0.1t}(\cos 2\pi 60t - 0.8 \sin 2\pi 60t)$.

Ans. $-j377, j377 \text{ sec}^{-1}; 0, -0.1 \text{ sec}^{-1}; -0.1 + j377, -0.1 - j377 \text{ sec}^{-1}$

14-2 A 5-ohm resistor and an initially charged 0.05-farad capacitor are in series with a voltage source $e_s(t)$ and a switch which closes at $t = 0$. What complex frequencies are associated with the current response if: (a) $e_s(t) = 0$; (b) $e_s(t) = 10e^{-2t}$; (c) $e_s(t) = 10 \cos 2t$?

Ans. -4 sec^{-1} ; $-4, j2$, $-j2 \text{ sec}^{-1}$; -4 , -2 sec^{-1}

14-3 A FURTHER INTERPRETATION OF COMPLEX FREQUENCY

The preceding discussion has shown us that the real and imaginary parts of the complex frequency describe, respectively, the exponential and sinusoidal variation of an exponentially varying sinusoid. It is apparent that the significance of a complex frequency is more general than is that of the everyday variety of frequency which describes the number of times some phenomenon repeats itself per unit time. Our ordinary concept of frequency, however, actually carries with it another connotation in addition to "repetitions per second." It also tells us something about the *rate of change* of the function being considered. That is, high frequency means "rapidly varying." Let us see if we can relate this connotation of frequency to the complex frequency of a complex exponential function of time. We again take

$$f(t) = \mathbf{K}e^{st} \quad (14-4)$$

After obtaining the time rate of change of $f(t)$,

$$\frac{df}{dt} = s\mathbf{K}e^{st}$$

we normalize by dividing by $f(t)$,

$$\frac{df/dt}{f} = s \quad (14-5)$$

This normalized rate of change is a constant, independent of time; it is identically equal to the complex frequency s . Thus, we may also interpret complex frequency as the *normalized time rate of change* of the complex exponential function (14-4). The use of this alternative definition of s on familiar functions which are *not* in the form of the complex exponential function (14-4) may lead to some curious results. Thus, although the complex frequency associated with the function e^{j5t} is $s = j5$, the normalized rate of change associated with $\cos 5t$ must be $(-5) \tan 5t$. If we try to treat this result, which is a function of time, as a complex frequency, then we are led to a complex frequency which is a function of time. The correct answer to our problem is obtained only when we recognize that a conjugate *pair* of complex frequencies is required to characterize $\cos 5t$; one complex frequency is insufficient.

Drill Problem

14-3 A network is composed of four different resistors and one inductor in some configuration which is immaterial to this problem. No sources

are present, but initial energy is present in the inductor. The voltage waveform across the inductor is displayed on an oscilloscope. At $t = 0.12$ sec, the inductor voltage is 20 volts, and it is decreasing at the rate of 100 volts/sec. After finding the complex frequency which characterizes this voltage, write a suitable functional form for the voltage and determine the instant of time at which: (a) the inductor voltage is 10 volts; (b) the rate of change of the inductor voltage is -10 volts/sec; (c) the rate of change of the inductor voltage is -1000 volts/sec.

Ans. -0.340 sec; 0.259 sec; 0.580 sec

14-4 THE DAMPED SINUSOIDAL FORCING FUNCTION

We have devoted enough time to the definition and introductory interpretation of complex frequency; it is now time to put this concept to work and become familiar with it by seeing what it will do and how it is used.

The general exponentially varying sinusoid, which we may represent as a voltage for the moment,

$$e(t) = E_m e^{\sigma t} \cos(\omega t + \theta) \quad (14-6)$$

is expressible in terms of the complex frequency s by making use of Euler's identity as before:

$$e(t) = \text{Re}(E_m e^{\sigma t} e^{j(\omega t + \theta)}) \quad (14-7)$$

$$\text{or } e(t) = \text{Re}(E_m e^{\sigma t} e^{j(-\omega t - \theta)}) \quad (14-8)$$

Either representation is suitable, and the two expressions should remind us that a pair of conjugate complex frequencies is associated with a sinusoid or an exponentially damped sinusoid. Equation (14-7) is more directly related to the given damped sinusoid, and we shall concern ourselves principally with it. Collecting factors,

$$e(t) = \text{Re}(E_m e^{j\theta} e^{(\sigma + j\omega)t})$$

we now substitute $s = \sigma + j\omega$, and obtain

$$e(t) = \text{Re}(E_m e^{j\theta} e^{st}) \quad (14-9)$$

Before we apply a forcing function of this form to any circuit, we should note the resemblance of this last representation of the damped sinusoid to the corresponding representation of the *undamped* sinusoid,

$$\text{Re}(E_m e^{j\theta} e^{j\omega t})$$

The only difference is that we now have s where we previously had $j\omega$. Instead of restricting ourselves to sinusoidal forcing functions and their angular frequencies, we have now extended our notation to include the damped sinusoidal forcing function at a complex frequency. It should be no surprise at all to see later in this section and the following one that we shall develop a *frequency-domain*

description of the exponentially damped sinusoid in exactly the same way that we did for the sinusoid; we shall simply omit the Re notation and suppress ϵ^{st} .

We are now ready to apply the exponentially damped sinusoid, as given by Eq. (14-6), (14-7), (14-8), or (14-9), to an electrical network. The forced response, say a current in some branch of the network, is the desired response. Since the forced response has the form of the forcing function, its integral, and its derivatives, the response may be assumed as

$$i(t) = I_m \epsilon^{\sigma t} \cos(\omega t + \phi)$$

or
$$i(t) = \text{Re} (I_m \epsilon^{j\phi} \epsilon^{st})$$

where the complex frequency of the source and the response must be identical.

If we now recall that the real part of a complex forcing function produces the real part of the response, while the imaginary part of the complex forcing function causes the imaginary part of the response, then we are again led to the application of a *complex* forcing function to our network. We shall obtain a complex response whose real part is the desired real response. Actually, we shall work with the Re notation omitted, but we should realize that it may be reinserted at any time and that it *must* be reinserted whenever we desire the time-domain response. Thus, given the real forcing function

$$e(t) = \text{Re} (E_m \epsilon^{j\theta} \epsilon^{st})$$

we apply the complex forcing function $E_m \epsilon^{j\theta} \epsilon^{st}$; the resultant complex response $I_m \epsilon^{j\phi} \epsilon^{st}$ must have as its real part the desired time-domain response

$$i(t) = \text{Re} (I_m \epsilon^{j\phi} \epsilon^{st})$$

The solution of our circuit-analysis problem must consist of the determination of the unknown response amplitude I_m and phase angle ϕ .

Before we actually carry out the details of an analysis problem and see how exactly the procedure follows that used in the sinusoidal and exponential frequency-domain analyses, it is worthwhile outlining the steps of the basic method. We must first characterize the circuit with a set of mesh or nodal integrodifferential equations. The given forcing functions, in complex form, and the assumed responses, also in complex form, are then substituted into the equations and the indicated integrations and differentiations performed. Each term in every equation will then contain the same factor ϵ^{st} . We shall therefore divide throughout by this factor, or “suppress ϵ^{st} ,” understanding that it must be reinserted if a time-domain description of any response function is desired. Now that the Re symbol and the ϵ^{st} factor have disappeared, we have converted all the voltages and currents from the time domain to the frequency domain. The integrodifferential equations have become algebraic equations, and their solution is obtained just as easily as they were in the sinusoidal steady state. Let us illustrate the basic method by a numerical example.

We shall apply the forcing function

$$e(t) = 60\epsilon^{-t} \cos(2t + 10^\circ)$$

400 Complex Frequency

to the series *RLC* circuit shown in Fig. 14-1, and we desire the forced response

$$i(t) = I_m \epsilon^{-t} \cos(2t + \phi)$$

We first express the forcing function in Re notation,

$$\begin{aligned} e(t) &= 60 \epsilon^{-t} \cos(2t + 10^\circ) \\ &= \text{Re}(60 \epsilon^{-t} \epsilon^{j(2t+10^\circ)}) \\ &= \text{Re}(60 \epsilon^{10^\circ} \epsilon^{(-1+j2)t}) \end{aligned}$$

or $e(t) = \text{Re}(\mathbf{E} \epsilon^{st})$

where

$$\mathbf{E} = 60/10^\circ \quad \text{and} \quad s = -1 + j2$$

After dropping Re, we are left with the complex forcing function

$$60/10^\circ \epsilon^{st}$$

In a similar manner, we represent the unknown response by the complex quantity

$$\mathbf{I} \epsilon^{st}$$

where

$$\mathbf{I} = I_m / \phi$$

Since we have not as yet extended the impedance concept to the exponentially damped sinusoid and complex frequency, our next step must be the integro-differential equation for our circuit. From Kirchhoff's voltage law we obtain

$$\begin{aligned} e(t) &= Ri + L \frac{di}{dt} + \frac{1}{C} \int i dt \\ &= 2i + \frac{di}{dt} + 2 \int i dt \end{aligned}$$

and we substitute the given complex forcing function and the assumed complex response into this equation,

$$60/10^\circ \epsilon^{st} = 2\mathbf{I} \epsilon^{st} + s\mathbf{I} \epsilon^{st} + \frac{2}{s} \mathbf{I} \epsilon^{st}$$

The common factor ϵ^{st} is next suppressed:

$$60/10^\circ = 2\mathbf{I} + s\mathbf{I} + \frac{2}{s} \mathbf{I}$$

and
$$\mathbf{I} = \frac{60/10^\circ}{2 + s + 2/s}$$

Before we evaluate this complex current, it is worth examining the form of this equation. The left side of the equation is a current, the numerator of the right side is a voltage, and the denominator must therefore have the dimensions of

Fig. 14-1 A series RLC circuit to which a damped sinusoidal forcing function is applied. A frequency-domain solution for $i(t)$ is desired.

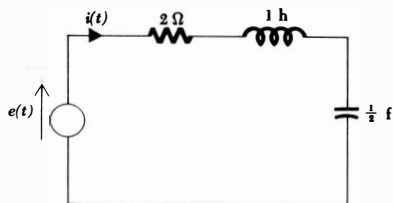

ohms; it is apparent that we shall soon interpret it as an impedance. Moreover, we might make some pretty astute guesses as to the impedance of each of the three passive elements at a complex frequency s . The impedance of the 2-ohm resistor is simply 2 ohms; the impedance of the 1-henry inductor is $1s$ or Ls ; and the impedance of the 0.5-farad capacitor is $2/s$ or $1/Cs$. These statements will be proved in the following section.

Going back to our numerical example, we now let $s = -1 + j2$ in the last equation and solve for the complex current I :

$$I = \frac{60/10^\circ}{2 + (-1 + j2) + 2/(-1 + j2)}$$

After manipulating the complex numbers for a few minutes, we find

$$I = 44.8/-53.4^\circ$$

Thus, I_m is 44.8 amp and ϕ is -53.4° . The desired forced response is thus

$$i(t) = 44.8e^{-t} \cos(2t - 53.4^\circ)$$

Now we must show that the impedance concept may be extended to complex frequencies. Except for the presence of complex numbers, the actual solution of the circuit equations will then be no different than the procedure used for purely resistive circuits.

Drill Problems

14-4 Express each of the following currents in the frequency domain:

(a) $5e^{-3t} \cos(10t - 30^\circ)$; (b) $-5e^{3t} \cos(100t + 60^\circ)$; (c) $5 \sin(15t + 120^\circ)$.

Ans. $5/30^\circ$ amp; $5/-30^\circ$ amp; $5/-120^\circ$ amp

14-5 Find the value at $t = 0.01$ sec of the frequency-domain voltage $100/30^\circ$ if: (a) $s = -50 + j50$; (b) $s = -50 - j50$; (c) $s = j50$.

Ans. 31.5 volts; 52.0 volts; 60.6 volts

14-6 Find the value of the frequency-domain current $10/45^\circ$ amp at $t = 1$ sec if: (a) $s = j\pi$; (b) $s = -1$; (c) $s = 0$.

Ans. 2.60 amp; 7.07 amp; -7.07 amp

14-5 *Z(s) AND Y(s)*

In order to apply Kirchhoff's laws directly to the complex forcing functions and complex responses, it is necessary to know the constant of proportionality between the complex voltage across an element and the complex current through it. This proportionality constant is the impedance or admittance of the element; it is easily determined for the resistor, inductor, and capacitor.

Let us consider the inductor carefully and then merely present the results for the other elements. Suppose that a voltage source

$$e(t) = E_m \epsilon^{\sigma t} \cos(\omega t + \theta)$$

is applied to an inductor L ; the current response must have the form

$$i(t) = I_m \epsilon^{\sigma t} \cos(\omega t + \phi)$$

The passive sign convention is employed, as indicated in Fig. 14-2*a*, the time-domain circuit. If we represent the voltage as

$$e(t) = \text{Re}(E_m \epsilon^{j\theta} \epsilon^{st}) = \text{Re}(\mathbf{E} \epsilon^{st})$$

and the current as

$$i(t) = \text{Re}(I_m \epsilon^{j\phi} \epsilon^{st}) = \text{Re}(\mathbf{I} \epsilon^{st})$$

then the substitution of these expressions into the defining equation of an inductor,

$$e(t) = L \frac{di(t)}{dt}$$

leads to

$$\text{Re}(\mathbf{E} \epsilon^{st}) = \text{Re}(sL \mathbf{I} \epsilon^{st})$$

We now drop Re , thus considering the complex response to a complex forcing function, and suppress the superfluous factor ϵ^{st} :

$$\mathbf{E} = sL \mathbf{I}$$

Fig. 14-2 (a) The time-domain inductor voltage and current are related by $e = L di/dt$. (b) The (complex) frequency-domain inductor voltage and current are related by $\mathbf{E} = sL \mathbf{I}$.

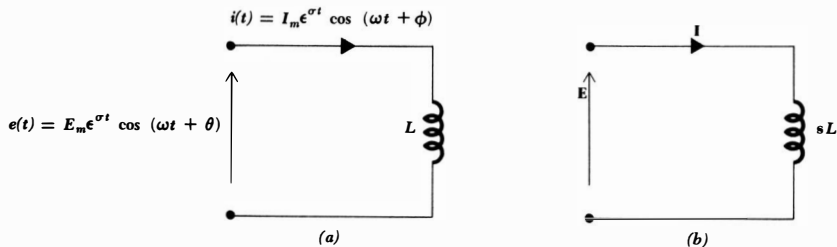

403 Complex Frequency

The ratio of the complex voltage to the complex current is once again the impedance. Since it depends in general upon the complex frequency s , this functional dependence is sometimes indicated by writing

$$\mathbf{Z}(s) = \frac{\mathbf{E}}{\mathbf{I}} = sL$$

In a similar manner, the admittance of an inductor L is

$$\mathbf{Y}(s) = \frac{1}{sL}$$

We shall still call \mathbf{E} and \mathbf{I} *phasors*. These complex quantities have an amplitude and phase angle which, along with a specific complex-frequency value, enable us to characterize the exponentially varying sinusoidal waveform completely. The phasor is still a frequency-domain description, but its application is not limited to the realm of radian frequencies. The frequency-domain equivalent of Fig. 14-2a is shown in Fig. 14-2b; phasor currents, phasor voltages, and impedances or admittances are now used.

The impedances of a resistor R and a capacitor C at a complex frequency s are obtained by a similar sequence of steps. Without going through the details, the results for a resistor are

$$\mathbf{Z}(s) = R \quad \mathbf{Y}(s) = G = \frac{1}{R}$$

and for a capacitor

$$\mathbf{Z}(s) = \frac{1}{sC} \quad \mathbf{Y}(s) = sC$$

If we now reconsider the series RLC example of Fig. 14-1 in the frequency domain, the source voltage

$$e(t) = 60e^{-t} \cos(2t + 10^\circ)$$

is transformed to the phasor voltage

$$\mathbf{E} = 60/10^\circ$$

a phasor current \mathbf{I} is assumed, and the impedance of each element at the complex frequency $s = -1 + j2$ is determined and placed on a frequency-domain diagram, Fig. 14-3. The unknown current is now easily obtained by dividing the phasor voltage by the sum of the three impedances:

$$\mathbf{I} = \frac{60/10^\circ}{2 + (-1 + j2) + 2/(-1 + j2)}$$

Thus, the previous result is obtained, but much more easily and rapidly.

It is hardly necessary to say that all the techniques which we have used in the past to simplify frequency-domain analysis, such as superposition, source transformations, duality, Thévenin's theorem, and Norton's theorem, are still

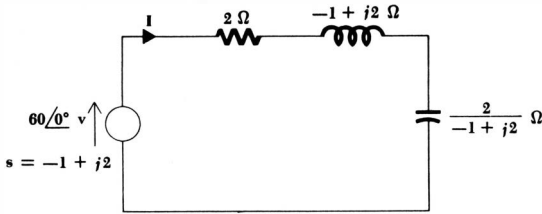

Fig. 14-3 The frequency-domain equivalent of the series RLC circuit shown in Fig. 14-1.

valid and useful. For example, the Thévenin equivalent of the network shown in Fig. 14-4a is obtained as follows:

The complex frequency is

$$s = -5 + j10$$

The frequency-domain source voltage is

$$\mathbf{E}_s = 100\angle 0^\circ$$

The inductor impedance is

$$\mathbf{Z}_L(s) = 4(-5 + j10) = -20 + j40$$

The resistor impedance is

$$\mathbf{Z}_R(s) = 20$$

The Thévenin impedance is the parallel equivalent of \mathbf{Z}_L and \mathbf{Z}_R :

$$\mathbf{Z}_{th} = \frac{20(-20 + j40)}{20 - 20 + j40} = 20 + j10$$

The open-circuit voltage is

$$\mathbf{E}_{oc} = 100\angle 0^\circ \frac{20}{20 - 20 + j40} = -j50$$

The frequency-domain Thévenin equivalent network is thus as shown in Fig. 14-4b. The return to the time domain is taken after some desired response

Fig. 14-4 (a) A given two-terminal network. (b) The frequency-domain Thévenin equivalent.

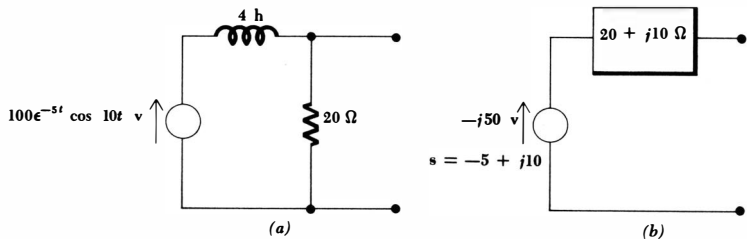

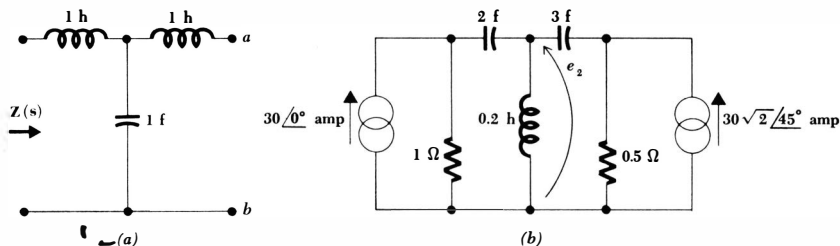

Fig. 14-5 (a) See Drill Probs. 14-7 and 14-8. (b) See Drill Prob. 14-9.

has been determined in the frequency domain. If another 4-henry inductor is placed across the open circuit, for example, the frequency-domain current is

$$\mathbf{I} = \frac{-j50}{20 + j10 - 20 + j40} = -1$$

corresponding to the time-domain current

$$i(t) = -e^{-5t} \cos 10t$$

Drill Problems

14-7 Find $\mathbf{Z}(s)$ for the network shown in Fig. 14-5a if terminals a and b are: (a) left open-circuited; (b) short-circuited; (c) terminated in a 1-ohm resistor.

$$\text{Ans. } \frac{s(s^2 + 2)}{s^2 + 1} \text{ ohms; } \frac{s^3 + s^2 + 2s + 1}{s^2 + s + 1} \text{ ohms; } \frac{s^2 + 1}{s} \text{ ohms}$$

14-8 For part b of Drill Prob. 14-7, find $\mathbf{Z}(s)$ at: (a) $s = -1$; (b) $s = j2$; (c) $s = -1 + j2$.

$$\text{Ans. } -1.3 + j1.6 \text{ ohms; } -1.5 \text{ ohms; } j1.333 \text{ ohms}$$

14-9 In the circuit shown in Fig. 14-5b, find $e_2(t)$ if: (a) $s = -1 + j1$; (b) $s = -1$; (c) $s = j1$.

$$\text{Ans. } -60e^{-t} \sin t \text{ volts; } 50e^{-t} \text{ volts; } -13.0 \cos(t - 64.3^\circ) \text{ volts}$$

14-6 THE COMPLEX-FREQUENCY PLANE

We have already considered circuit response as a function of frequency, where the frequency was either the neper frequency σ or the radian frequency ω . Quantities such as impedance, admittance, specific voltages or currents, voltage gain and current gain, and transfer impedances and admittances have been written as functions of σ or ω , their poles and zeros determined, and the graphical response has been presented. Let us now consider how we may

develop a more general graphical presentation by graphing quantities as functions of s ; that is, we wish to show the response simultaneously as functions of both σ and ω .

Such a graphical portrayal of the response as a function of the complex frequency s is a useful, enlightening technique in the analysis of circuits, as well as in the design or synthesis of circuits. After we have developed the concept of the complex-frequency plane, or s plane, we shall see how quickly the behavior of a circuit can be approximated from a graphical representation of its critical frequencies in this s plane. The converse procedure is also very useful; if we are given a desired response curve (the frequency response of a filter, for example), it will be possible to decide upon the necessary location of its poles and zeros in the s plane and then to synthesize the filter. This synthesis problem is a subject for detailed study in subsequent courses and is not one which we shall do more than briefly examine here. The s plane is also the basic tool with which the possible presence of undesired oscillations is investigated in feedback amplifiers and automatic control systems. In fact, if any recently (post World War II) developed concept of circuit analysis were to be singled out and called revolutionary, it might well be the introduction of the concept of complex frequency and the use of the s plane.

Let us develop a method of obtaining circuit response as a function of s by extending the methods we have been using to find the response as a function of either σ or ω . To review these methods, let us obtain the driving-point impedance of a network composed of a 3-ohm resistor in series with a 4-henry inductor. As a function of s , we have

$$\mathbf{Z}(s) = 3 + 4s$$

If we wish to obtain a graphical interpretation of the impedance variation with σ , we let $s = \sigma + j0$,

$$\mathbf{Z}(\sigma) = 3 + 4\sigma$$

and recognize a zero at $\sigma = -\frac{3}{4}$ and a pole at infinity. These critical frequencies are marked on a σ axis, and after identifying the value of $\mathbf{Z}(\sigma)$ at some convenient noncritical frequency [perhaps $\mathbf{Z}(0) = 3$], it is easy to plot $\mathbf{Z}(\sigma)$ versus σ .

In order to plot the response as a function of the radian frequency ω , we let $s = 0 + j\omega$,

$$\mathbf{Z}(j\omega) = 3 + j4\omega$$

and then obtain both the magnitude and phase angle of $\mathbf{Z}(j\omega)$ as functions of ω :

$$|\mathbf{Z}(j\omega)| = \sqrt{9 + 16\omega^2}$$

$$\text{ang } \mathbf{Z}(j\omega) = \tan^{-1} \frac{4\omega}{3}$$

The magnitude function shows a single pole at infinity and a minimum at $\omega = 0$; it can be readily sketched as a curve of $|\mathbf{Z}(j\omega)|$ versus ω . The phase

angle is an inverse tangent function, zero at $\omega = 0$ and $\pm 90^\circ$ at $\omega = \pm\infty$; it is also easily presented as a plot of $\text{ang } Z(j\omega)$ versus ω .

In graphing the response as a function of the neper frequency σ , we are able to present all the information on a single two-dimensional graph, $Z(\sigma)$ versus σ . When sinusoidal excitation is assumed, however, two two-dimensional plots are required, magnitude and phase angle as functions of ω . Of course, we might also have used two curves to display $Z(\sigma)$ versus σ , magnitude versus σ , and phase angle, which is either 0 or 180° , versus σ . The important point to note is that there is only one independent variable, σ in the case of exponential excitation and ω in the sinusoidal case. Now let us consider what alternatives are available to us if we wish to plot a response as a function of s .

The complex frequency s requires two parameters σ and ω for its complete specification. The response is also a complex function, and we must therefore consider sketching both the magnitude and phase angle as functions of s . Either of these quantities, for example, the magnitude, is a function of the two parameters σ and ω , and we can only plot it in two dimensions as a family of curves, such as magnitude versus ω , with σ as parameter. Conversely, we could also show the magnitude versus σ , with ω as the parameter. Such a family of curves represents a tremendous amount of work, however, and this is what we are trying to avoid; it is also questionable whether we could ever draw any useful conclusions from the family of curves even after they were obtained.

A better method of representing the magnitude of some complex response graphically involves using a *three-dimensional* model. Although such a model is difficult to draw on a two-dimensional sheet of paper, we shall find that the model is not difficult to visualize; most of the drawing will be done mentally, where few supplies are needed and construction, correction, and erasures are quickly accomplished. Let us think of a σ axis and a $j\omega$ axis, perpendicular to each other, laid out on a horizontal surface such as the floor. The floor now represents a *complex-frequency plane*, or *s plane*, as sketched in Fig. 14-6. To each point in this plane there corresponds exactly one value of s , and to each value of s we may associate a single point in this complex plane.

Since we are already quite familiar with the type of time-domain function associated with a particular value of the complex frequency s , it is now possible to associate the functional form of a forcing function or a response with the various regions in the s plane. The origin, for example, must represent a d-c

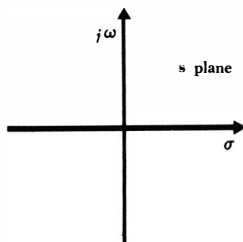

Fig. 14-6 The complex-frequency plane, or s plane.

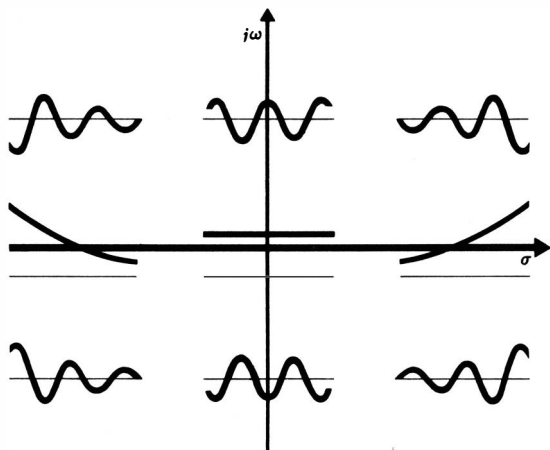

Fig. 14-7 The nature of the time-domain function is sketched in the region of the complex-frequency plane to which it corresponds.

quantity. Points lying on the σ axis must represent exponential functions, decaying for $\sigma < 0$ and rising for $\sigma > 0$. Pure sinusoids are associated with points on the positive or negative $j\omega$ axis. The right half of the s plane, usually referred to simply as the RHP, contains points describing frequencies with positive real parts and thus corresponds to time-domain quantities which are exponentially increasing sinusoids, except on the σ axis. Correspondingly, points in the left half of the s plane (LHP) describe the frequencies of exponentially decreasing sinusoids, again with the exception of the negative σ axis. Figure 14-7 summarizes the relationship between the time domain and the various regions of the s plane.

Let us now return to our search for an appropriate method of representing a response graphically as a function of the complex frequency s . The magnitude of the response may be represented by constructing, say, a plaster model whose height above the floor at every point corresponds to the magnitude of the response at that value of s . In other words, we have added a third axis, perpendicular to both the σ axis and the $j\omega$ axis and passing through the origin; this axis is labeled $|Z|$, $|Y|$, $|E_2/E_1|$, or with whatever symbol is appropriate. The response magnitude is determined for every value of s , and the resultant plot is a *surface* lying above (or just touching) the s plane.

Let us try out these preliminary ideas by seeing what such a plaster model might look like. As an example, we may consider the admittance of the series combination of a 1-henry inductor and a 3-ohm resistor,

$$Y(s) = \frac{1}{s + 3}$$

In terms of both σ and ω we have, as the magnitude,

$$|Y(s)| = \frac{1}{\sqrt{(\sigma + 3)^2 + \omega^2}}$$

When $s = -3 + j0$, the response magnitude is infinite; and when s is infinite, the magnitude of $\mathbf{Y}(s)$ is zero. Thus our model must be infinitely high over the point $(-3 + j0)$, and it must be zero height at all points infinitely far away from the origin. A cutaway view of such a model is shown in Fig. 14-8a.

Once the model is constructed, it is simple to visualize the variation of $|\mathbf{Y}|$ as a function of ω (with $\sigma = 0$) by cutting the model with a perpendicular plane containing the $j\omega$ axis. The model shown in Fig. 14-8a happens to be cut along this plane, and the desired plot of $|\mathbf{Y}|$ versus ω can be seen; the curve is also drawn in Fig. 14-8b. In a similar manner, a vertical plane containing the σ axis enables us to obtain $|\mathbf{Y}|$ versus σ (with $\omega = 0$), shown in Fig. 14-8c.

How might we obtain some qualitative response information without doing all this work? After all, most of us have neither the time nor the inclination to be good plasterers, and some more practical method is needed. Let us visualize the s plane once again as the floor and then imagine a larger rubber sheet laid on it. We now fix our attention on all the poles and zeros of the response. At each zero, the response is zero, the height of the sheet must be zero, and we therefore tack the sheet to the floor. At the value of s corresponding to each pole, we may prop up the sheet with a thin vertical rod. Zeros and poles at infinity must be treated by using a large radius clamping ring or a high circular fence, respectively. If we have used an infinitely large, weightless, perfectly elastic sheet, tacked down with vanishingly small tacks, and propped up with infinitely long, zero-diameter rods, then the rubber sheet assumes a height which is exactly proportional to the magnitude of the response. These rubber-sheet

Fig. 14-8 (a) A cutaway view of a plaster model whose top surface represents $|\mathbf{Y}(s)|$ for the series combination of a 1-henry inductor and a 3-ohm resistor. (b) $|\mathbf{Y}(s)|$ as a function of ω . (c) $|\mathbf{Y}(s)|$ as a function of σ .

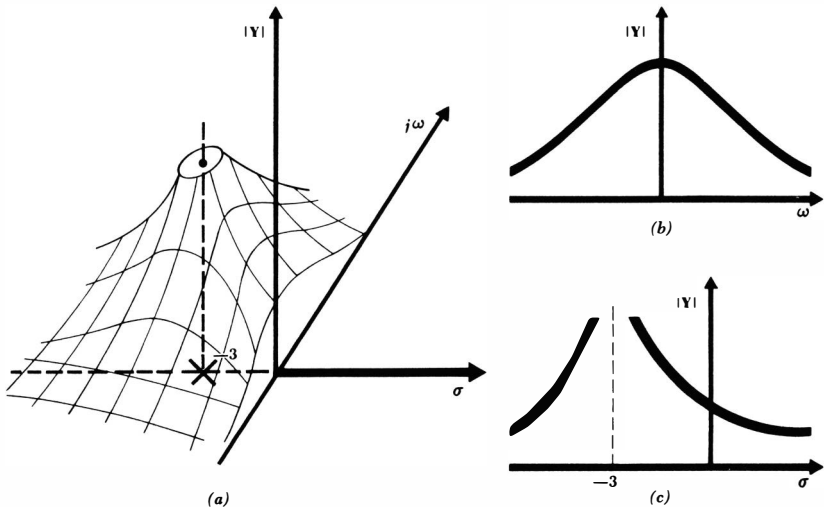

410 Complex Frequency

models may actually be constructed in the laboratory, but their main advantage lies in the ease by which their construction may be visualized from a knowledge of the pole-zero locations of the response.

These comments may be illustrated by considering the configuration of the poles and zeros, sometimes called a *pole-zero constellation*, which locates all the critical frequencies of some frequency-domain quantity, say the impedance $\mathbf{Z}(s)$. Such a pole-zero constellation is shown in Fig. 14-9a. If we visualize a rubber-sheet model, tacked down at $s = -2 + j0$ and propped up at $s = -1 + j5$ and $-1 - j5$, we should see a terrain whose distinguishing features are two mountains and one conical crater or depression. The portion of the model for the upper left half of the s plane is shown in Fig. 14-9b.

Let us now build up the expression for $\mathbf{Z}(s)$ which leads to this pole-zero configuration. The zero requires a factor of $(s + 2)$ in the numerator, and the two poles require the factors $(s + 1 - j5)$ and $(s + 1 + j5)$ in the denominator. Except for a multiplying constant k , we now know the form of $\mathbf{Z}(s)$:

$$\mathbf{Z}(s) = k \frac{s + 2}{(s + 1 - j5)(s + 1 + j5)}$$

$$\text{or } \mathbf{Z}(s) = k \frac{s + 2}{s^2 + 2s + 26} \quad (14-10)$$

Let us select k by assuming a single additional fact about $\mathbf{Z}(s)$; let $\mathbf{Z}(0) = 1$. By direct substitution in Eq. (14-10), we find that k is 13, and therefore

$$\mathbf{Z}(s) = 13 \frac{s + 2}{s^2 + 2s + 26} \quad (14-11)$$

Fig. 14-9 (a) The pole-zero configuration of some impedance $\mathbf{Z}(s)$. (b) A portion of the rubber-sheet model of the magnitude of $\mathbf{Z}(s)$.

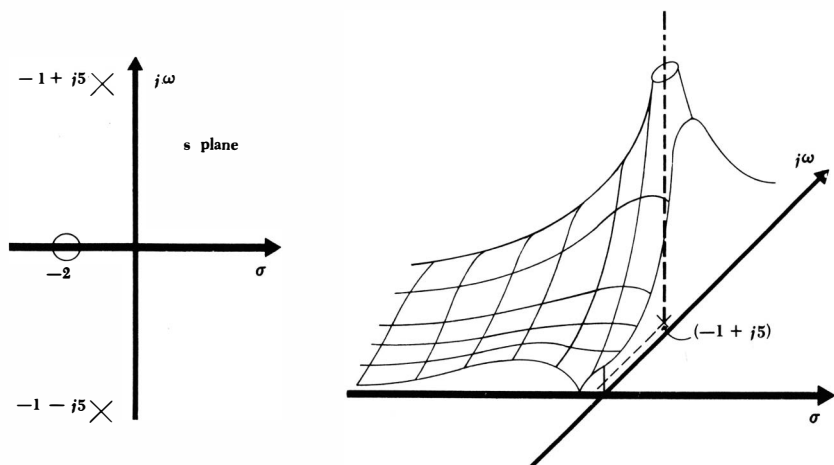

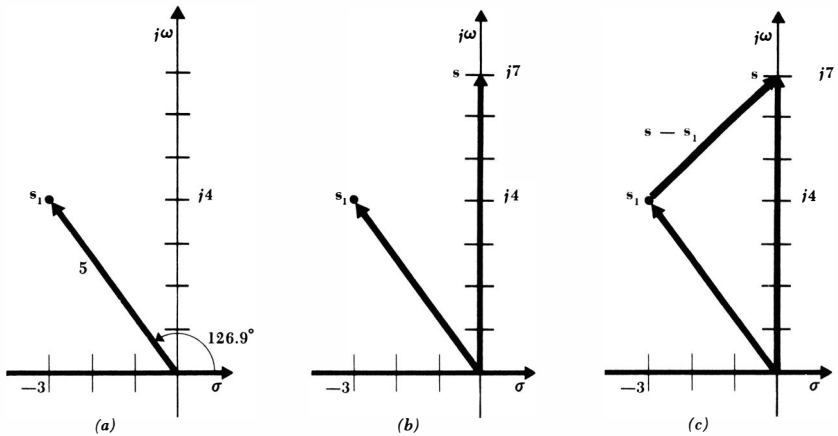

Fig. 14-10 (a) The complex frequency $s_1 = -3 + j4$ is indicated by drawing an arrow from the origin to s_1 . (b) The frequency $s = j7$ is also represented vectorially. (c) The difference $s - s_1$ is represented by the vector drawn from s_1 to s .

The plots $|Z(\sigma)|$ versus σ and $|Z(j\omega)|$ versus ω may be obtained exactly from Eq. (14-11), but the general form of the function is apparent from the pole-zero configuration and the rubber-sheet analogy. Portions of these two curves appear at the sides of the model shown in Fig. 14-9b.

Thus far, we have been using the s plane and the rubber-sheet model to obtain *qualitative* information about the variation of the *magnitude* of the frequency-domain function with frequency. It is possible, however, to get *quantitative* information concerning the variation of both the *magnitude* and *phase angle*. The method provides us with a powerful new tool.

Consider the representation of a complex frequency in polar form, as suggested by an arrow drawn from the origin of the s plane to the complex frequency under consideration. The length of the arrow is the magnitude of the frequency, and the angle that the arrow makes with the positive direction of the σ axis is the angle of the complex frequency. The frequency $s_1 = -3 + j4 = 5/126.9^\circ$ is indicated in Fig. 14-10a.

It is also necessary to represent the difference between two values of s as an arrow or vector on the complex plane. Let us select a value of s that corresponds to a sinusoid $s = j7$ and indicate it also as a vector, as shown in Fig. 14-10b. The *difference* $s - s_1$ is seen to be the vector drawn from the last-named point s_1 to the first-named point s ; the vector $s - s_1$ is drawn in Fig. 14-10c. Note that $s_1 + (s - s_1) = s$. Numerically, $s - s_1 = j7 - (-3 + j4) = 3 + j3 = 4.24/45^\circ$, and this value agrees with the graphical difference.

Let us see how this graphical interpretation of the difference $(s - s_1)$ enables us to determine frequency response. Consider the admittance

$$Y(s) = s + 2$$

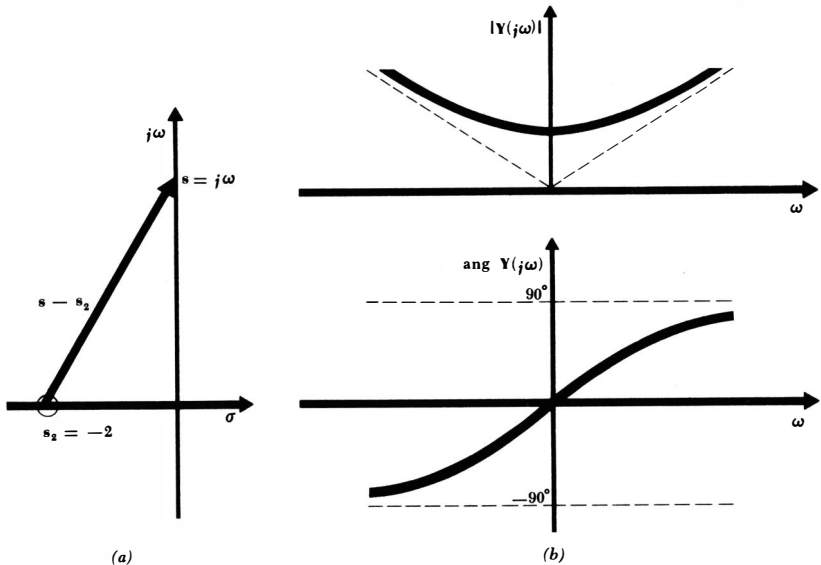

Fig. 14-11 (a) The vector representing the admittance $Y(s) = s + 2$ is shown for $s = j\omega$. (b) Sketches of $|Y(j\omega)|$ and $\text{ang } Y(j\omega)$ as they might be obtained from the performance of the vector as s moves up the $j\omega$ axis from the origin.

This expression may be interpreted as the difference between some frequency of interest s and a zero location. Thus, the zero is present at $s_2 = -2 + j0$, and the factor $s + 2$, which may be written as $s - s_2$, is represented by the vector drawn from the zero location s_2 to the frequency s at which the response is desired. If the sinusoidal response is desired, s must lie on the $j\omega$ axis, as illustrated in Fig. 14-11a. The magnitude of $s + 2$ may now be visualized as ω varies from zero to infinity. When s is zero, the vector has a magnitude of 2 and an angle of 0° . Thus $Y(0) = 2$. As ω increases, the magnitude increases, slowly at first, and then almost linearly with ω ; the phase angle increases almost linearly at first, and then gradually approaches 90° as ω becomes infinite. At $\omega = 7$, $Y(j7)$ has a magnitude of $\sqrt{2^2 + 7^2}$ and has a phase angle of $\tan^{-1}(3.5)$. The magnitude and phase of $Y(s)$ are sketched as functions of ω in Fig. 14-11b.

Let us now construct a more realistic example by considering a frequency-domain function given by the quotient of two factors,

$$E(s) = \frac{s + 2}{s + 3}$$

We again select a value of s which corresponds to sinusoidal excitation and draw the vectors $s + 2$ and $s + 3$, the first from the zero to the chosen point on the $j\omega$

413 **Complex Frequency**

axis and the second from the pole to the chosen point. The two vectors are sketched in Fig. 14-12a. The quotient of these two vectors has a magnitude equal to the quotient of the magnitudes and a phase angle equal to the difference of the numerator and denominator phase angles. An investigation of the variation of the magnitude of $E(s)$ versus ω is made by allowing s to move from the origin up the $j\omega$ axis and considering the ratio of the distance from the zero to $s = j\omega$ and the distance from the pole to the same point on the $j\omega$ axis. The ratio evidently is $\frac{2}{3}$ at $\omega = 0$ and approaches unity as ω becomes infinite. A consideration of the difference of the two phase angles shows that $\text{ang } E(j\omega)$ is 0° at $\omega = 0$, increases at first as ω increases since the angle of the vector $s + 2$ is greater than that of $s + 3$, and then decreases with a further increase in ω , finally approaching 0° at infinite frequency, where both vectors possess 90° angles. These results are sketched in Fig. 14-12b. Although no quantitative markings are present on these sketches, it is important to note that they may be obtained easily. For example, the complex response at $s = j4$ must be given by the ratio

$$E(j4) = \frac{\sqrt{4 + 16} / \tan^{-1}(\frac{4}{2})}{\sqrt{9 + 16} / \tan^{-1}(\frac{4}{3})}$$

$$E(j4) = \frac{\sqrt{20} \angle \tan^{-1} 2 - \tan^{-1}(\frac{4}{3})}{\sqrt{25} \angle \tan^{-1} 2 - \tan^{-1}(\frac{4}{3})}$$

$$= 0.894 / 10.3^\circ$$

Fig. 14-12 (a) Vectors are drawn from the two critical frequencies of the voltage response $E(s) = (s + 2)/(s + 3)$. (b) Sketches of the magnitude and phase of $E(j\omega)$ as obtained from the quotient of the two vectors shown in (a).

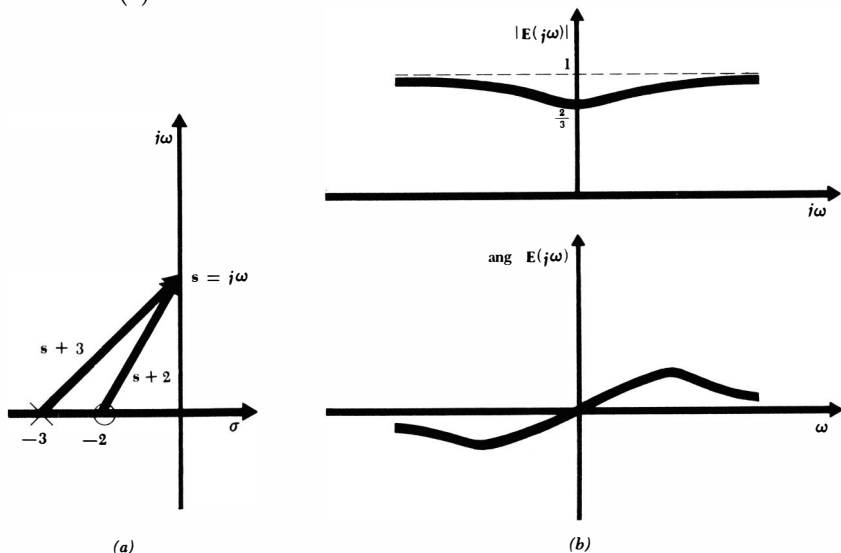

In designing networks to produce some desired response, the behavior of the vectors drawn from each critical frequency to a general point on the $j\omega$ axis is an important aid. For example, if it were necessary to increase the hump in the phase response of Fig. 14-12*b*, we can see that we must provide a greater difference in the angles of the two vectors. This may be achieved in Fig. 14-12*a* either by moving the zero closer to the origin or by locating the pole farther from the origin, or both.

The ideas we have been discussing to help in the graphical determination of the magnitude and angular variation of some frequency-domain function with frequency will be needed in the following chapter when we investigate the frequency performance of highly selective filters, or resonant circuits. These concepts are fundamental in obtaining a quick, clear understanding of the behavior of electrical networks and other engineering systems. The procedure is briefly summarized as follows:

1. Draw the pole-zero configuration of the frequency-domain function under consideration in the s plane, and locate a test point corresponding to the frequency at which the function is to be evaluated.
2. Draw an arrow from each pole and zero to the test point.
3. Determine the length of each pole arrow and zero arrow and the value of each pole-arrow angle and zero-arrow angle.
4. Divide the product of the zero-arrow lengths by the product of the pole-arrow lengths. This quotient is the magnitude of the frequency-domain function for the assumed frequency of the test point [within a multiplying constant, since $F(s)$ and $kF(s)$ have the same pole-zero constellations].
5. Subtract the sum of the pole-arrow angles from the sum of the zero-arrow angles. The resultant difference is the angle of the frequency-domain function, evaluated at the frequency of the test point. The angle does not depend upon the value of the real multiplying constant k .

Fig. 14-13 See Drill Probs. 14-10 and 14-12.

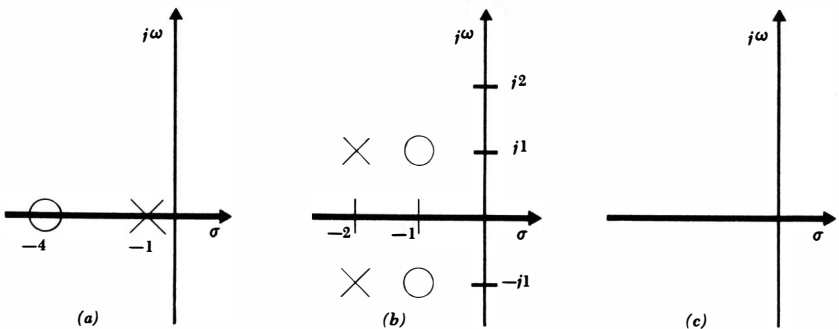

Drill Problems

14-10 Each of the pole-zero configurations shown in Fig. 14-13 is associated with an admittance having a value of 4 mhos at infinite frequency. Write each $Y(s)$ as the ratio of two polynomials in s .

Ans. $\frac{4s + 16}{s + 1}$ mhos; 4 mhos; $\frac{4s^2 + 8s + 8}{s^2 + 4s + 5}$ mhos

14-11 For the network of Fig. 14-14a, draw the pole-zero configuration of the voltage transfer function: (a) E_4/E_1 ; (b) E_3/E_1 ; (c) E_2/E_1 .

Ans. $-0.5 \pm j1.5 \text{ sec}^{-1}$; $-0.5 \pm j1.5, -5 \text{ sec}^{-1}$; $-0.5 \pm j1.5, -0.25 \pm j1.561 \text{ sec}^{-1}$

14-12 Use a graphical interpretation to find the value of the admittance whose pole-zero plot is shown in Fig. 14-13a, remembering that $Y(\infty) = 4$, at: (a) $s = -2 + j0$; (b) $s = -10 + j0$; (c) $s = 0 + j3$.

Ans. $6.32/\underline{-34.7^\circ}$ mhos; 2.67 mhos; $8/\underline{180^\circ}$ mhos

14-13 Use the pole-zero configuration shown in Fig. 14-14b to estimate the positive radian frequency at which the response: (a) magnitude is a maximum; (b) magnitude is a minimum; (c) phase angle is $+90^\circ$

Ans. $\omega \doteq 5, (5.43)$; $\omega \doteq 2, (1.876)$; $\omega \doteq 5, (4.85)$

Fig. 14-14 (a) See Drill Prob. 14-11. (b) See Drill Prob. 14-13.

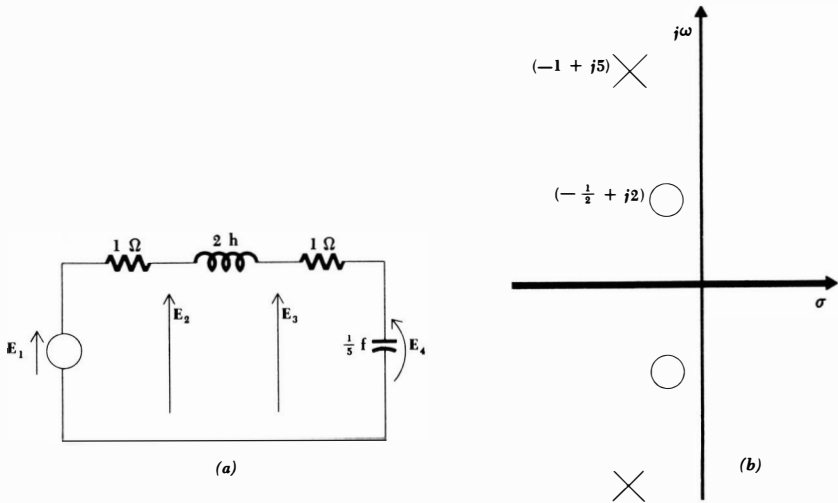

14-7 NATURAL RESPONSE AND THE s PLANE

There is a tremendous amount of information contained in the pole-zero plot of some response in the s plane. We shall find out how the complete current response, natural plus forced, produced by an arbitrary voltage forcing function can be quickly written from the pole-zero configuration of the impedance offered to the voltage source and from the initial conditions; the method is similarly effective for the dual problem, the complete voltage response produced by a current source.

Let us introduce the method by considering the simplest example, a series RL circuit as shown in Fig. 14-15. A general voltage source $e(t)$ causes the current $i(t)$ to flow after closure of the switch at $t = 0$. The complete response $i(t)$ is composed of a natural response and a forced response:

$$i(t) = i_n(t) + i_f(t) \quad (14-12)$$

We may find the forced response by working in the frequency domain, assuming, of course, that $e(t)$ has a functional form which we can transform to the frequency domain; if $e(t) = t^2$, we must proceed as best we can from the basic differential equation for the circuit. We therefore have

$$\mathbf{I}_f(s) = \frac{\mathbf{E}(s)}{R + sL}$$

or

$$\mathbf{I}_f(s) = \frac{1}{L} \frac{\mathbf{E}(s)}{s + R/L} \quad (14-13)$$

and $i_f(t)$ is obtained by replacing s , L , and R by their values, reinserting e^{st} , and taking the real part. The answer may even be obtained as a function of a general ω , σ , R , and L if desired.

Now let us consider the natural response. Of course, we know that the form will be a decaying exponential with the time constant L/R , but we may pretend that we are finding it for the first time. The natural response or *source-free* response is, by definition, of a form independent of the forcing function; the forcing function contributes, along with the other initial conditions, only to the magnitude of the natural response. In order to find the proper form, we replace all sources by their internal impedances; here, $e(t)$ is replaced by a short circuit. Now let us try to obtain this natural response as a limiting case of the forced response; we return to the frequency-domain expression (14-13) and obediently

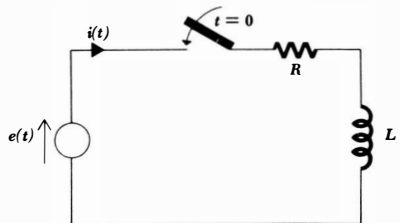

Fig. 14-15 An example which illustrates the determination of the complete response through a knowledge of the critical frequencies of the impedance faced by the source.

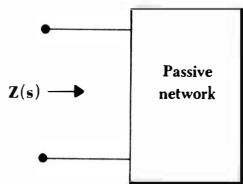

Fig. 14-16 The zeros of $Z(s)$ determine the form of the natural response of the current which would flow in a short circuit across the input terminals.

set $E(s) = 0$. On the surface, it appears that $I(s)$ must also be zero, but this is not necessarily true; the denominator may be zero. In other words, if we apply no voltage at the frequency $s = -R/L$, some current at this frequency may flow. It is of course necessary that there be some energy stored initially in the circuit for this to occur.

Let us inspect this new idea from a slightly different vantage point. The forced response to the given voltage source is

$$I_f(s) = \frac{E(s)}{Z(s)}$$

If we happen to apply a voltage at the exact frequency of one of the zeros of $Z(s)$, then an infinite current will flow. This is true even though only $1 \mu\text{v}$ is applied. We then conclude that a finite current at this frequency may flow even though no voltage is applied. Since the circuit is now source-free, that current is of the form of the source-free or natural response.

Returning to our series RL circuit, we see by Eq. (14-13) that infinite current results when the operating frequency is $s = -R/L + j0$. A finite current at this frequency thus represents the natural response

$$I(s) = A \quad \text{at } s = -\frac{R}{L} + j0$$

Transforming this natural response to the time domain,

$$i_n(t) = \text{Re} (A\epsilon^{-Rt/L})$$

or
$$i_n(t) = A\epsilon^{-Rt/L}$$

To complete this example, the total response is then

$$i(t) = A\epsilon^{-Rt/L} + i_f(t)$$

and A may be determined once the initial conditions are specified for this circuit.

Now let us generalize these results. Figure 14-16 shows a general RLC passive network with one pair of input terminals. The input impedance at these terminals may be written in a form which displays all the critical frequencies:

$$Z(s) = k \frac{(s - s_1)(s - s_3) \cdots}{(s - s_2)(s - s_4) \cdots} \quad (14-14)$$

It is customary to designate the zeros of an impedance or the poles of an admittance by odd-numbered subscripts; impedance poles and admittance zeros re-

ceive even-numbered subscripts. Hence, the zeros of $Z(s)$ occur at $s = s_1$, $s = s_3$, etc., and if a voltage is applied to the input terminals at any of these frequencies, infinite current will flow. Thus, a finite current at each of these frequencies must be a possible functional form for the natural response. Therefore, we think of a zero-volt source (which is just a short circuit) applied to the input terminals; the natural response which occurs when the input terminals are short-circuited must thus have the form

$$i_n(t) = A_1 e^{s_1 t} + A_3 e^{s_3 t} + \dots$$

where the A 's must be evaluated in terms of the initial conditions (including the initial value of any voltage source applied at the input terminals).

Let us now consider the dual of this problem. Again we may refer to the passive network shown in Fig. 14-16, but let us suppose for the moment that a current source is applied at the input terminals. The input voltage response is then

$$E(s) = I(s)Z(s)$$

If we happen to apply a current at the frequency of one of the poles of $Z(s)$, an infinite-amplitude input voltage results; it follows then that if we apply a zero-amplitude current (an open circuit) at this frequency, a finite response may be present at the same frequency. This is a source-free response, and it is identifiable as the natural response. Hence, if we assume the input impedance is expressed in the form of Eq. (14-14), then the functional form of the natural voltage response across the open-circuited input terminals must be

$$e_n(t) = A_2 e^{s_2 t} + A_4 e^{s_4 t} + \dots$$

The open-circuit natural voltage response is composed of a sum of terms at the frequencies of the poles of the input impedance or, stated slightly differently, at the frequencies of the zeros of the input admittance. The short-circuit natural current response is composed of a sum of terms at the frequencies of the zeros of the input impedance or the poles of the input admittance.

Let us now try out these techniques on two examples. The first circuit is shown in Fig. 14-17, and it is identical with that of Fig. 5-17, a network whose natural response was found earlier with a great deal of difficulty. Let us again find the form of i_1 and i_2 . Considering i_1 first, we must find a suitable location for the short circuit through which this current flows; let us use the points marked x and x' . The input impedance viewed from these terminals when they are open-circuited is

$$Z(s) = 2s + 1 + \frac{6s}{3s + 2}$$

$$\text{or } Z(s) = 2 \frac{(s + 2)(s + \frac{1}{6})}{s + \frac{2}{3}}$$

Thus, i_1 must be of the form

$$i_1(t) = A_1 e^{-2t} + A_3 e^{-t/6}$$

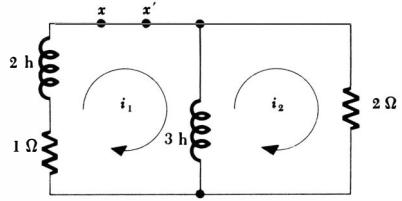

Fig. 14-17 The circuit shown in Fig. 5-17 is redrawn here. The natural responses i_1 and i_2 are desired.

The solution is completed by using the given initial conditions (i_1 and i_2 are both 11 amp at $t = 0$) to establish the values of A_1 and A_3 . Although we have been able to obtain the *form* of the solution much more rapidly than we did before, we cannot shorten the procedure for obtaining the initial conditions; any saving in effort here must come later with a study of the Laplace transform. For practice, let us complete the solution for i_1 . Since $i_1(0)$ is given as 11, then

$$11 = A_1 + A_3$$

The necessary additional equation is obtained by differentiating i_1 :

$$\left. \frac{di_1}{dt} \right|_{t=0} = -2A_1 - \frac{1}{6}A_3$$

But $2di_1/dt$ is the voltage across the 2-henry inductor, and Kirchhoff's voltage law shows that this must be the sum of the initial voltages across the two resistors. Thus

$$\left. \frac{di_1}{dt} \right|_{t=0} = \frac{11 + 22}{2} = -2A_1 - \frac{1}{6}A_3$$

Thus, $A_1 = 3$ and $A_3 = 8$, and the desired solution is

$$i_1(t) = 3e^{-2t} + 8e^{-t/6}$$

The solution for i_2 obtained in Chap. 5 may be checked by inspecting the impedance obtained when the right-hand mesh is broken.

As our last example we shall find the complete response $e(t)$ of the circuit shown in Fig. 14-18. The switch is closed prior to $t = 0$, and thus all currents and voltages to the right of the switch are initially zero. At $t = 0$ the switch is

Fig. 14-18 A circuit whose complete response is to be found through an investigation of its critical frequencies.

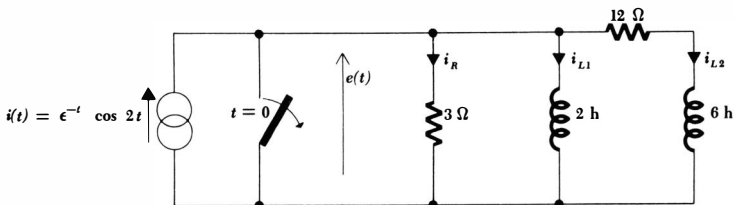

opened, and the voltage across the switch is to be found. This response is composed of both a forced and a natural response,

$$e(t) = e_n(t) + e_f(t)$$

Each may be found through a knowledge of the pole-zero configuration of the input impedance or admittance of the portion of the network to the right of the switch. Remembering that an inactive current source is an open circuit, and that the switch is also an open circuit for $t > 0$, the natural response $e_n(t)$ is thus composed of a sum of terms, each term corresponding to a pole of the input impedance or a zero of the input admittance. We have for $\mathbf{Y}(s)$

$$\mathbf{Y}(s) = \frac{1}{3} + \frac{1}{2s} + \frac{1}{6s + 12}$$

or, after combining and factoring,

$$\mathbf{Y}(s) = \frac{1}{3} \frac{(s + 1)(s + 3)}{s(s + 2)} \quad (14-15)$$

The form of the natural response may now be written

$$e_n(t) = A_2 e^{-t} + A_4 e^{-3t}$$

In order to find the forced response, the frequency-domain current source $\mathbf{I}(s) = 1$ at $s = -1 + j2$ may be divided by the input admittance, evaluated at $s = -1 + j2$,

$$\begin{aligned} \mathbf{E}(s) &= \frac{\mathbf{I}(s)}{\mathbf{Y}(s)} = \frac{1}{\mathbf{Y}(-1 + j2)} \\ &= 3 \frac{(-1 + j2)(1 + j2)}{j^2(1 + j2)} \end{aligned}$$

and thus

$$\mathbf{E}(s) = 1.875 \sqrt{2} \angle 45^\circ$$

Transforming to the time domain, we have

$$e_f(t) = 1.875 \sqrt{2} e^{-t} \cos(2t + 45^\circ)$$

The complete response is therefore

$$e(t) = A_2 e^{-t} + A_4 e^{-3t} + 1.875 \sqrt{2} e^{-t} \cos(2t + 45^\circ)$$

Since the current through both inductors is initially zero, the initial source current of 1 amp must flow through the 3-ohm resistor. Thus

$$e(0) = 3 = A_2 + A_4 + \frac{1.875 \sqrt{2}}{\sqrt{2}} \quad (14-16)$$

Again it is necessary to differentiate and then to obtain an initial condition for de/dt . We first find

$$\left. \frac{de}{dt} \right|_{t=0} = 1.875 \sqrt{2} \left(-\frac{2}{\sqrt{2}} - \frac{1}{\sqrt{2}} \right) - A_2 - 3A_4$$

421 Complex Frequency

or
$$\left. \frac{de}{dt} \right|_{t=0} = -5.625 - A_2 - 3A_4 \quad (14-17)$$

The initial value of this rate of change is obtained by analyzing the circuit. However, those rates of change which are most easily found are the derivatives of the inductor currents, for $e = L di/dt$, and the initial values of the inductor voltages should not be difficult to find. We therefore express the response $e(t)$ in terms of the resistor current,

$$e(t) = 3i_R$$

and then apply Kirchhoff's current law,

$$e(t) = 3i - 3i_{L1} - 3i_{L2}$$

Now we may take the derivative,

$$\frac{de}{dt} = 3 \frac{di}{dt} - 3 \frac{di_{L1}}{dt} - 3 \frac{di_{L2}}{dt}$$

Differentiation of the source function and evaluation at $t = 0$ provide a value of -3 volts/sec for the first term; the second term is numerically $\frac{3}{2}$ of the initial voltage across the 2-henry inductor, or -4.5 volts/sec; and the last term is -1.5 volts/sec. Thus,

$$\left. \frac{de}{dt} \right|_{t=0} = -9$$

and we may now use Eqs. (14-16) and (14-17) to determine the unknown amplitudes

$$A_2 = 0 \quad A_4 = 1.125$$

The complete response is therefore

$$e(t) = 1.125\epsilon^{-3t} + 1.875\sqrt{2}\epsilon^{-t} \cos(2t + 45^\circ)$$

In spite of the detailed process which we must pursue to evaluate the amplitude coefficients of the natural response, except in those cases where the initial values of the desired response and its derivatives are obvious, we should not lose sight of the ease and rapidity with which the form of the natural response can be obtained.

Drill Problems

14-14 Consider the circuit shown in Fig. 14-19a. Assume that the series combination of a battery and a switch which closes at $t = 0$ is connected in series with one of the branches of the circuit. Determine the frequency components present in the natural response of the battery current if the battery and switch are placed in: (a) branch ab ; (b) branch bc ; (c) branch cf .

Ans. $-3, -30 \text{ sec}^{-1}; -3, -30 \text{ sec}^{-1}; -3, -30 \text{ sec}^{-1}$

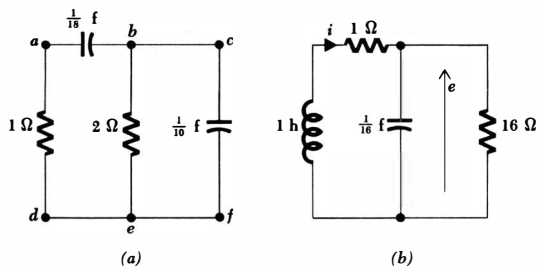

Fig. 14-19 (a) See Drill Probs. 14-14, 14-15, 14-16, and 14-17. (b) See Drill Prob. 14-18.

14-15 The network shown in Fig. 14-19a contains stored energy at $t = 0$. At $t = 0$, one of the branches is suddenly opened and the voltage determined across the open circuit. Find the frequency components present in this natural response if the opened branch is: (a) branch ab ; (b) branch be ; (c) branch cf .

Ans. 0, -28 sec^{-1} ; 0, -5 sec^{-1} ; 0, -6 sec^{-1}

14-16 The parallel combination of a constant current source and a switch which opens at $t = 0$ is connected between two points of the circuit shown in Fig. 14-19a. Find the frequency components present in the voltage across the opened switch if the combination is placed across: (a) points a and d ; (b) points b and e ; (c) points a and b .

Ans. -3 , -30 sec^{-1} ; -3 , -30 sec^{-1} ; -3 , -30 sec^{-1}

14-17 The technique of obtaining the form of the natural response by an inspection of immittance poles and zeros is also applicable to transfer immittances. Let a battery and switch which closes at $t = 0$ be placed in series in branch ad of Fig. 14-19a. Determine the frequency components of the natural response: (a) current in branch be ; (b) voltage across branch ab ; (c) voltage across branch cf .

Ans. -3 , -30 sec^{-1} ; -3 , -30 sec^{-1} ; -3 , -30 sec^{-1}

14-18 Find $i(t)$ for $t > 0$ in the circuit shown in Fig. 14-19b if the following initial conditions are given: (a) $i(0^+) = 1 \text{ amp}$; $\frac{di}{dt}\bigg|_{0^+} = 3$

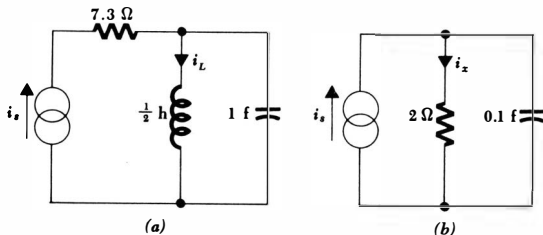

Fig. 14-20 (a) See Prob. 5. (b) See Prob. 7.

amp/sec; (b) $i(0^+) = 0$; $e(0^+) = 10$ volts; (c) $e(0^+) = 10$ volts; $\left. \frac{de}{dt} \right|_{0^+} = -6$ volts/sec.

Ans. $2.52\epsilon^{-t} \cos(4t + 84.3^\circ)$ amp; $1.414\epsilon^{-t} \cos(4t - 45^\circ)$ amp; $2.50\epsilon^{-t} \cos(4t + 90^\circ)$ amp

Problems

- ◆1 Write the time-domain voltage which is represented in complex form by $\mathbf{K}_1\epsilon^{s_1 t} + \mathbf{K}_2\epsilon^{s_2 t}$, where: (a) $\mathbf{K}_1 = \mathbf{K}_2^* = 1 + j3$ and $s_1 = s_2^* = j20$; (b) $\mathbf{K}_1 = \mathbf{K}_2^* = 60/30^\circ$ and $s_1 = s_2^* = -3 + j20$.
- 2 Find $i(t)$ if $s = -100 + j1000$ and: (a) $\mathbf{I} = 3$; (b) $\mathbf{I} = 0.02s$; (c) $\mathbf{I} = 1.1 + 0.001s$.
- 3 The current $i(t) = 2\epsilon^{-2t} \cos(4t + 30^\circ)$ amp is applied to the parallel combination of a 2-ohm resistor, a 1-henry inductor, and a $\frac{1}{8}$ -farad capacitor. The voltage $e(t)$ across the source is desired. Write a suitable integrodifferential equation for the circuit, express $i(t)$ as a complex forcing function and assume a complex response function, substitute these functions into the equation, obtain the complex voltage response, and from this determine the time-domain response $e(t)$.
- ◆4 The voltage $e_s = 100\epsilon^{\sigma t} \cos \omega t$ is applied to an impedance $\mathbf{Z}(s) = 3 + 0.4s$. Find the resultant current $i(t)$ if: (a) $\sigma = -20$, $\omega = 0$; (b) $\sigma = 0$, $\omega = 10$; (c) $\sigma = -15$, $\omega = 10$.
- ◆5 In the circuit shown in Fig. 14-20a, let $i_s = 12\epsilon^{-t/2} \cos(1.5t + 30^\circ)$ amp be the source current. Find $i_L(t)$.
- 6 The voltage $100\epsilon^{-10^5 t} \cos 10^5 t$ volts is applied to a 1- μf capacitor. Find the steady-state capacitor current $i(t)$.
- ◆7 The circuit shown in Fig. 14-20b is in the steady state. If the source current is $i_s = 20\epsilon^{-8t} \cos(4t + 30^\circ)$, find $i_x(t)$.
- 8 A current source of complex frequency s is connected to each of the three networks shown in Fig. 14-21. The voltage across the network is the response. Find all the values of s which are poles or zeros of the response, and identify each as a pole or zero.

Fig. 14-21 See Prob. 8.

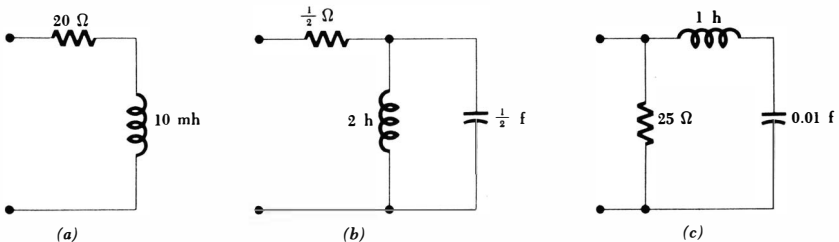

- 9 Locate all the poles and zeros of the impedances given below, and indicate the position of these critical frequencies (except for $s = \infty$) on the s plane:

(a) $Z(s) = 10 + \frac{2}{s}$

(b) $Z(s) = \frac{10}{s} + \frac{20}{s+4}$

(c) $Z(s) = \frac{10s^2 + 70s + 60}{s^2 + 4s}$

◆(d) $Z(s) = s + 4 + \frac{20}{s}$

(e) $Z(s) = \frac{10s^3 + 60s^2 + 100s}{2s^2 + 6s + 10}$

- ◆10 Locate all the poles and zeros of the input admittance for each network shown in Fig. 14-22. Indicate the positions on the s plane.
- 11 With reference to the circuit of Fig. 14-23a, $e_0(t)$ is desired for $t > 0$. Assume that the voltage across C_2 is zero for $t < 0$. The box labeled K is an ideal amplifier having these properties: $Z_{in} = \infty$, $Z_{out} = 0$, $e_2(t) = Ke_1(t)$. The circuit of Fig. 14-23b is a simplified equivalent circuit. (a) Find $e_1(t)$, given $E_0 = 60$ volts, $L_1 = 10$ henrys, $C_1 = 1/40.1$ farad, $R_1 = 2$ ohms. (b) Find $e_2(t)$ if $K = -10$. (c) The voltage response $e_0(t)$ is composed of both a forced and a natural response. Find the forced response if $R_2 = 1$ ohm and $C_2 = 1/40.1$ farad. (d) Select the proper form for the natural response, evaluate the necessary constants, and show that $e_0(t) = 3e^{-40.1t} - 3e^{-0.1t} \cos 2t$.
- ◆12 A 0.1-mho conductance and a 0.02-farad capacitor are in parallel. Make a pole-zero plot on the s plane of the admittance of the network, and de-

Fig. 14-22 See Prob. 10.

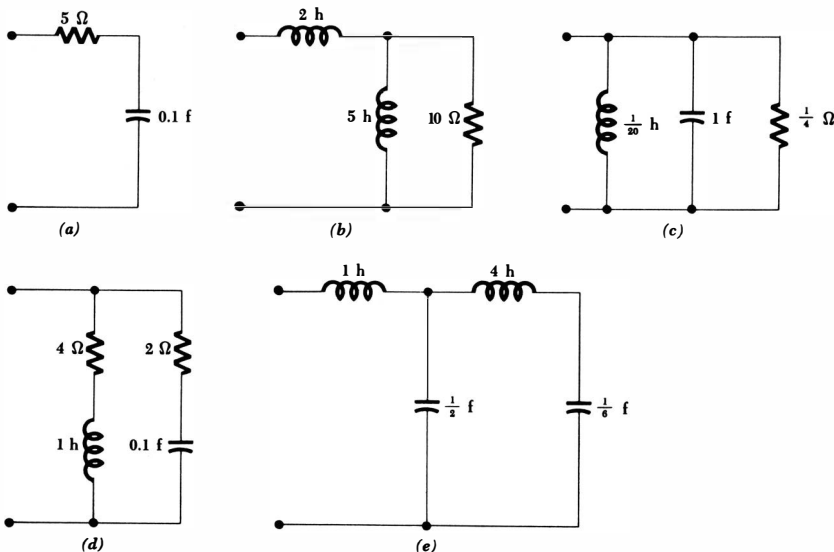

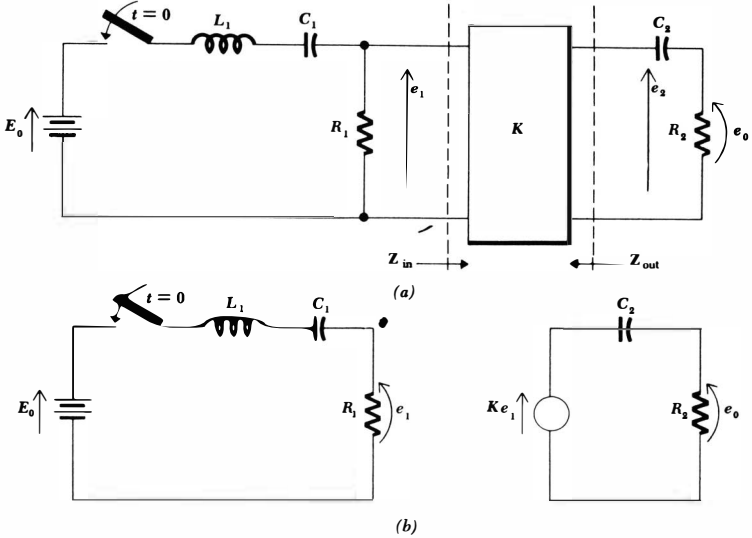

Fig. 14-23 See Prob. 11.

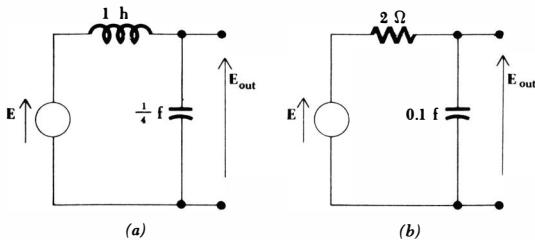

Fig. 14-24 See Prob. 14.

termine qualitatively from the plot $|Y|$ versus ω , $\text{ang } Y$ versus ω , and $|Y|$ versus σ .

- 13 Rework Prob. 12 in terms of the impedance of the same network.
- 14 For the networks shown in Fig. 14-24, determine E_{out}/E as a function of s , plot the poles and zeros of E_{out}/E in the s plane, and sketch $|E_{\text{out}}/E|$ and the phase angle of E_{out}/E versus ω .
- ◆15 Two pole-zero plots on the s plane are shown in Fig. 14-25. (a) Assume that each applies to an impedance $Z(s)$, and write an expression for $Z(s)$ except for a multiplying factor. (b) Repeat if the plots apply to an admittance $Y(s)$. (c) Determine the multiplying factors for parts a and b if $|Z| = 100$ ohms at $s = j\omega$, $\omega = 10$, for Fig. 14-25a.
- 16 The pole-zero configuration for the input admittance of a certain network consists of a single zero at $s = -3$ and a single pole at $s = -1$. It is also known that $Y(0) = 1.5$ mhos. (a) What is the phase angle of the imped-

- ance $Z(s)$ if a sinusoidal forcing function having $\omega = 3$ is applied? (b) What is the complete numerical expression for $Y(s)$?
- ◆17 An impedance $Z(s)$ possesses a pole-zero plot on the s plane which shows one zero at $s = -10$ and one pole at $s = -10\sqrt{3}$. If $Z(\infty) = 2$, find: (a) $Z(j10)$; (b) $Z(-j10)$; (c) $Z(-10 + j1)$.
- 18 For the network shown in Fig. 14-26a: (a) find $Z(-1)$; (b) find $Z(j1)$; (c) find $Z(1 + j1)$; (d) list all the poles and zeros of $Z(s)$; (e) show the location of the poles and zeros of $Z(s)$ on the s plane; (f) sketch $|Z(j\omega)|$ versus ω . Be accurate for $\omega = 0$ and for $\omega \rightarrow \infty$.
- 19 Sketch $|Y(j\omega)|$ versus ω and $\text{ang } Y(j\omega)$ versus ω for the admittance whose pole-zero configuration is shown in Fig. 14-13a. $Y(\infty) = 4$ mhos.
- 20 Sketch $Y(\sigma)$ versus σ for the admittance having the critical frequencies indicated in Fig. 14-13b. $Y(\infty) = 4$ mhos.

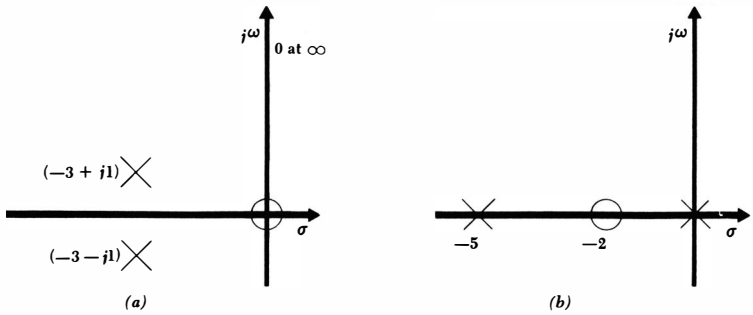
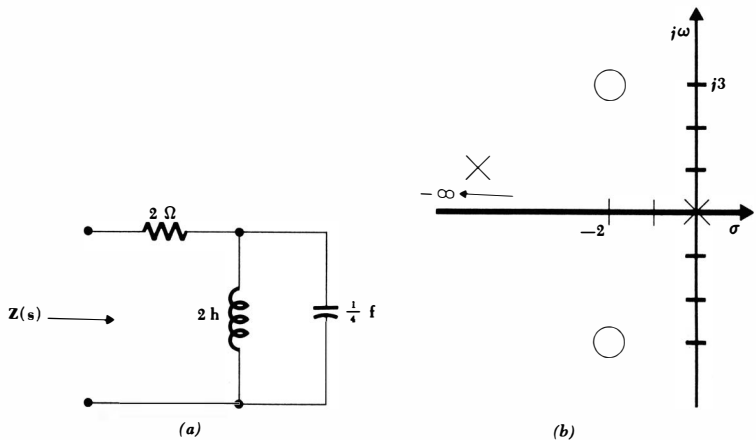

Fig. 14-25 See Prob. 15.

Fig. 14-26 (a) See Prob. 18. (b) See Prob. 21.



- 21 The pole-zero plot of a certain impedance is shown in Fig. 14-26*b*. Let $Z(-1) = -10$. ♦(a) Write an expression for $Z(s)$. (b) Express $Z(s)$ in the form $k_1s + k_2 + 1/k_3s$, where the k 's are positive real constants, and by inspection draw the circuit, including element values, whose impedance is $Z(s)$.
- 22 A certain impedance has a pole at the origin and a zero at $s = -5$. (a) Write an expression for $Z(s)$, including a multiplying constant K . (b) Evaluate K if $Z(-1) = -20$. (c) Sketch $|Z(j\omega)|$ versus ω . (d) By inspection of the expression for $Z(s)$, draw a circuit which will provide this $Z(s)$. (e) Discuss the paths (loci) followed by the pole and zero as each element is decreased in value to zero and increased in value.
- 23 All the critical frequencies of an admittance $Y(s)$ are shown on the pole-zero plot of Fig. 14-27*a*. Write an expression for $Y(s)$, including a multiplying factor K . If $|Y(-1)| = 400$: ♦(a) express $Y(s)$ as a constant times the ratio of two polynomials in s with real coefficients; (b) sketch $|Y(j\omega)|$ versus ω , $-50 \leq \omega \leq 50$; (c) by inspection of the expression for $Y(s)$, draw a network which will provide this $Y(s)$.
- 24 For the circuit shown in Fig. 14-27*b*, $Z(s) = 8(s + 4)/(s + 2)$. (a) Determine the form for $i(t)$, $t > 0$, except for unknown amplitudes. (b) If $i(0) = 10$ and $\left. \frac{di}{dt} \right|_{t=0} = 5$, determine $i(t)$ exactly for $t > 0$. (c) If the switch has been closed for a very long time and is opened at $t = 0$, write the functional form for $e(t)$, $t > 0$. (d) Determine the exact form for $e(t)$, $t > 0$, if $e(0) = 400$ volts. (e) By using the expression for $Z(s)$ and a little ingenuity

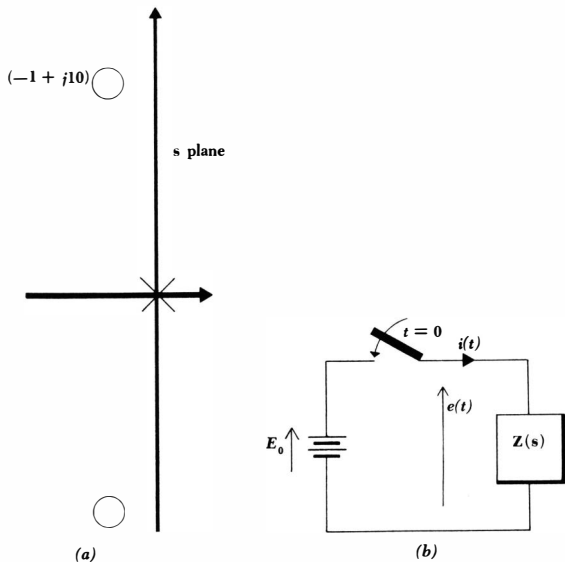
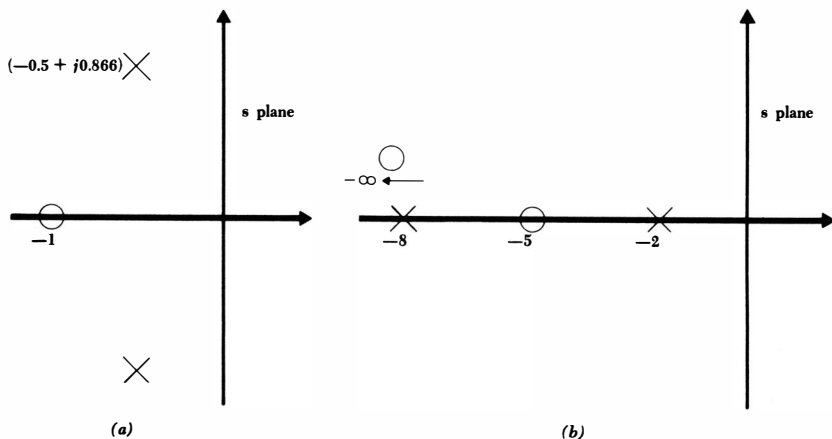

Fig. 14-27 (a) See Prob. 23. (b) See Prob. 24.

(for example, dividing the denominator into the numerator) the form of the expression can be changed until a specific network having this $Z(s)$ can be recognized. Draw such a network.

- ◆25 The pole-zero plot of a certain impedance $Z(s)$ shows a single pole at $s = -4$ and a single zero at $s = -1$. It is also known that $Z(s) \rightarrow 3$ as $s \rightarrow \infty$. (a) Write an expression for $Z(s)$. (b) A 6-volt battery and a switch are placed in series with $Z(s)$. The switch is closed at $t = 0$. Find the battery current $i(t)$ if $i(0) = 2$ amp.
- 26 The pole-zero configuration of an input admittance is shown in Fig. 14-28a. A 1-volt battery is connected in parallel with this admittance at $t = 0$. The battery current $i(t)$ is zero at $t = 0$, and its time rate of change at this time is 1 amp/sec. Find the complete response $i(t)$ if $Y(0) = 1$.
- ◆27 The pole-zero constellation of an impedance is shown in Fig. 14-28b. Assume $Z(0) = \frac{5}{6}$. Internal energy storage within the network causes the open-circuit voltage $e(t)$ to be 10 volts at $t = 0$ and to have an initial rate of change of -8 volts/sec. Find the complete response $e(t)$ for $t > 0$.
- 28 The circuit shown in Fig. 14-29a has been in the condition shown for a very long time. At $t = 0$, the switch is opened. Find $e(t)$ for $t > 0$, and sketch $e(t)$ versus t .
- ◆29 The switch shown in the circuit of Fig. 14-29b has been open for a long time. It is closed at $t = 0$. Find $i(t)$ for $t > 0$.
- 30 With reference to the network shown in Fig. 14-30a: (a) Find $Z(s)$. (b) Plot the poles and zeros of $Z(s)$ on the s plane, determine $Z(s)$ as $s \rightarrow \infty$, and then visualize a rubber-sheet model and sketch $|Z|$ versus ω , $s = j\omega$. (c) From an accurate pole-zero plot, use a scale and protractor to determine $|s - s_1|$, $\text{ang}(s - s_1)$, etc., for $s = j\omega$, where $\omega = 0, 1, 2, 3, 5, 10$, and 20. From these data calculate and plot $|Z|$ and $\text{ang} Z$ versus ω . (d) Let $s = j\omega$ and calculate and plot $|Z|$ and $\text{ang} Z$ versus ω by direct evaluation

Fig. 14-28 (a) See Prob. 26. (b) See Prob. 27.



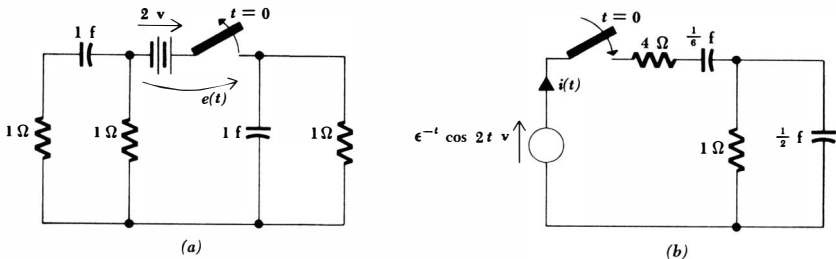

Fig. 14-29 (a) See Prob. 28. (b) See Prob. 29.

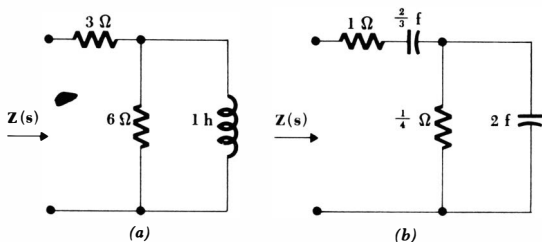

Fig. 14-30 (a) See Prob. 30. (b) See Prob. 31.

- of $Z(j\omega)$. Use the values of ω given above. (e) Comment on the work involved and the accuracy achieved with the three methods used above to obtain $|Z|$ and $\text{ang } Z$ versus ω . (f) Let the current flowing down in the 6-ohm resistor be $i(t)$. From the knowledge of the poles and zeros of $Z(s)$, specify the form of $i(t)$ if the input terminals are short-circuited and the inductance contains stored energy. (g) If the energy in the inductor is 50 joules at $t = 0$, find $i(t)$. (h) Specify the form of $i(t)$ if the input terminals are left open-circuited. (i) If the energy in the inductor is 50 joules at $t = 0$, find $i(t)$.
- 31 (a) Find $Z(s)$ for the network shown in Fig. 14-30b. (b) Locate all poles and zeros of $Z(s)$ on the s plane and specify the performance as $s \rightarrow \infty$. (c) Sketch $|Z(\sigma)|$ versus σ , $-10 \leq \sigma \leq 10$. (d) If each capacitor is initially charged and the input terminals are short-circuited at $t = 0$, write the form of the current flowing through the short circuit for $t > 0$. Arbitrary amplitude constants should be used. (e) What is the form of this short-circuit current if each capacitor is initially charged to 100 volts, with their common terminal positive?

Chapter **15** *Frequency Response*

15-1 INTRODUCTION

Frequency response is a subject which has come up for consideration often in the preceding two chapters. After the exponential forcing function and the neper frequency σ were introduced in Chap. 13, we discussed plots of admittance, impedance, current, and voltage as functions of σ , and the pole-zero concept was introduced as an aid in constructing and interpreting response curves. Response as a function of the radian frequency ω was also discussed from the same standpoint. In the last chapter, we broadened our concept of frequency and introduced the complex frequency s and the s plane. We found that a plot of the critical frequencies of a response on the complex-frequency plane enabled us to tie together the forced response and the natural response; the critical frequencies themselves presented us almost directly with the form of the natural response, and the visualization of a three-dimensional rubber-sheet model or the performance of vectors drawn from each critical frequency to some test frequency gave us valuable information concerning the variation of the forced response with frequency.

In this chapter, we shall concentrate again on the forced response, and we shall particularly consider its variation with the radian frequency ω .

Why should we be so interested in the response to sinusoidal forcing functions when we so seldom encounter them in practice as such? The electric power industry is an exception, for the sinusoidal waveform appears throughout, although it is sometimes necessary to consider other frequencies introduced by the non-linearity of some devices. But in most other electrical systems, the forcing functions and responses are not sinusoidal. In any system in which information is to be transmitted, the sinusoid by itself is almost valueless; it contains no information because its future values are exactly predictable from its past values.

We have learned earlier, however, that periodic nonsinusoidal functions can be represented as the sum of an infinite number of sinusoids by the use of the Fourier series, which will be the subject of Chap. 20. Superposition, therefore,

enables us to find the response of a network to nonsinusoidal waveforms from a knowledge of the sinusoidal waveforms of which they are composed. As a hypothetical example, let us suppose that a certain forcing function is found to contain sinusoidal components having frequencies within the range of 10 to 100 cps. Now let us imagine this forcing function being applied to a network which has the property that all sinusoidal voltages with frequencies from zero to 200 cps applied at the input terminals appear doubled in magnitude at the output terminals, with no change in phase angle. The output function is therefore an undistorted facsimile of the input function, but with twice the amplitude. If, however, the network has a frequency response such that the magnitudes of input sinusoids between 10 and 50 cps are multiplied by a different factor than are those between 50 and 100 cps, then the output would in general be distorted; it would no longer be a magnified version of the input. This distorted output might be desirable in some cases and undesirable in others. That is, the network frequency response might be chosen deliberately to reject some frequency components of the forcing function, or to emphasize others.

The importance of frequency response is not limited to electrical systems, however; an understanding of electrical frequency response is certainly helpful in analyzing the frequency response of, say, a mechanical system. Suppose that we consider the launching of an interplanetary spacecraft from the surface of the earth (or moon). The booster will subject the spacecraft to extreme nonsinusoidal vibration, the mechanical forcing function, with frequency components from a few cycles per second up to perhaps 50 cps. The structural members of the spacecraft will be deflected or distorted, the mechanical response, by an amount which depends on the sinusoidal components of the vibrational forces and on the frequency response of the spacecraft. From this information, a prediction as to whether or not the spacecraft can survive the rigors of the launch operation can be made. If the mechanical response at some vibration frequency is found to be excessive, then that component of the booster vibration must be reduced, a redesign of the spacecraft must be undertaken, or some vibration dampers (filters) must be provided. Failure to pay attention to the frequency response may cause the entire interplanetary mission to be aborted.

This example should not make us think that it is undesirable to have the network response at some particular frequency be much larger than the response at all other frequencies. Such behavior is characteristic of tuned circuits or resonant circuits, as we shall see in this chapter. In discussing resonance we shall be able to apply all the methods we have discussed in presenting frequency response.

15-2 IMMITTANCE LOCI

In plotting impedances and admittances as functions of frequency, we have had to draw two curves, one of the magnitude and the other of the phase angle. The alternative possibility of giving the real part and imaginary part was also avail-

able. Two curves were required, however, and we are now ready to discuss how this information can be presented on a single curve. In doing so, we might suspect that we have to lose somewhere, and it will turn out that we shall not be able to see quite as clearly the exact variation of the response with frequency.

Any immittance function, say the impedance $Z(s)$, can be described in terms of its real part and imaginary part. Thus, at the radian frequency ω we may write

$$Z(j\omega) = r + jx$$

where r and x are both real functions of ω . Now let us construct a *complex impedance plane*, or Z plane, having an abscissa r and an ordinate jx , as shown in Fig. 15-1a. At a given radian frequency, the impedance is then indicated by a single point in the Z plane. As the radian frequency changes, the position of the point changes and traces out a path or *locus* on the Z plane. In this section we shall discuss the easiest methods of obtaining these loci for both impedances and admittances; the loci may then be used as additional aids in determining the characteristics of the frequency response. Other types of loci useful in the analysis of systems containing feedback will also be mentioned.

Let us now consider the impedance locus of a series RL network consisting of a 1-ohm resistor and a 2-henry inductor. We have

$$Z(s) = 1 + 2s$$

or
$$Z(j\omega) = 1 + j2\omega$$

At $\omega = 1$, the impedance is $1 + j2$, as indicated by the point located on the Z plane of Fig. 15-1b. Sometimes an arrow is drawn from the origin to the point on the Z plane, but we cannot keep such a procedure up for long when we allow the point to trace a continuous curve in the plane; there simply is not room for all the arrows.

In order to obtain the locus, we recognize

$$r = 1 \quad jx = j2$$

No matter what value of ω is selected, r is equal to 1, and thus the locus must be some portion of the vertical straight line 1 unit to the right of the jx axis. As ω increases from zero to infinity, the point traces out a semi-infinite straight line¹ extending upward from the r axis, as shown in Fig. 15-2a. It is apparent that all values of ω cannot be marked on the locus, but the points at which $\omega = 0$ and $\omega = \infty$ should be indicated, and the direction of traverse as ω increases should be indicated by placing an arrow on the locus itself. Any special frequencies should also be marked, such as the frequency ω_1 at which the impedance phase angle is 45° .

The variation of the magnitude and the phase angle of $Z(j\omega)$ with ω is now clear from the locus, for the vector drawn from the origin to any point on the locus has a length and an angle which correspond to the magnitude and phase angle of the impedance. As frequency increases from zero, the impedance mag-

¹A semi-infinite straight line is a straight line extending from a finite point to infinity.

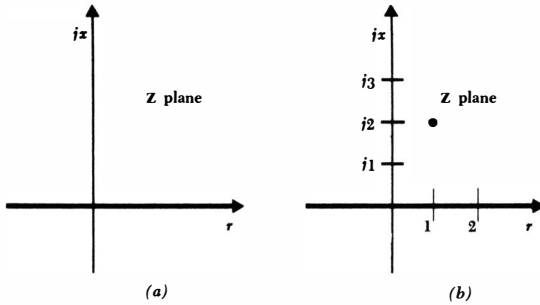

Fig. 15-1 (a) The Z plane. (b) The specific impedance $Z = 1 + j2$ is indicated on the Z plane.

nitude increases slowly from its initial value of 1 ohm and finally approaches an infinite magnitude as ω approaches ∞ . The phase angle begins at 0° and eventually approaches 90° .

A series RC circuit is described by

$$Z(s) = R + \frac{1}{sC} \quad Z(j\omega) = R - j\frac{1}{\omega C}$$

and therefore also has a semi-infinite straight line as its locus, shown in Fig. 15-2b.

Now let us consider an admittance locus for a parallel RLC circuit. We have

$$Y(j\omega) = \frac{1}{R} + j\left(\omega C - \frac{1}{\omega L}\right)$$

and we plot this locus on a Y plane having the g axis for its abscissa and the jb axis for its ordinate; that is,

$$Y(j\omega) = g + jb$$

where g and b are real functions of ω . Once again, the real part of this locus is a constant and the locus must be some portion of a straight line. The susceptance b is given by

$$b = \omega C - \frac{1}{\omega L}$$

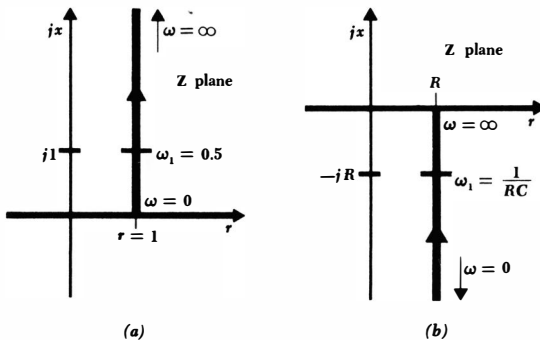

Fig. 15-2 (a) The impedance locus of a series network containing a 1-ohm resistor and a 2-h inductor. (b) The impedance locus of a series RC circuit.

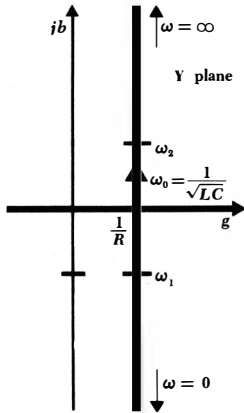

Fig. 15-3 The admittance locus of a parallel RLC circuit. The resonant frequency ω_0 and the two half-power frequencies ω_1 and ω_2 are marked.

and thus b takes on all values from $-\infty$ (when $\omega = 0$) to $+\infty$ (when $\omega = \infty$). The locus is therefore the complete straight line shown in Fig. 15-3. There are several special frequencies which are of interest; these frequencies will each be carefully defined in Sec. 15-4. The resonant frequency, at which the admittance is a pure conductance, is designated as ω_0 and is evidently equal to $1/\sqrt{LC}$. The lower and upper half-power frequencies ω_1 and ω_2 are the frequencies at which the admittance phase angle is -45° or $+45^\circ$; we shall obtain expressions for them later.

The loci we have constructed have all been straight lines. Now let us consider a slightly more difficult example by determining the admittance locus of the series RC circuit. Before writing any analytical expressions, we may construct the locus by purely geometrical methods; that is, the Z locus is given in Fig. 15-2b, admittance is the reciprocal of impedance, and we should certainly be able to obtain the reciprocal of the complex number representing any point on the Z locus. For example, the impedance phase angle goes from 0 to -90° , and the admittance phase angle therefore goes from 0 to $+90^\circ$; the impedance magnitude goes from R to infinity, and the admittance magnitude must change from $1/R$ to zero; the impedance locus is entirely in the fourth quadrant

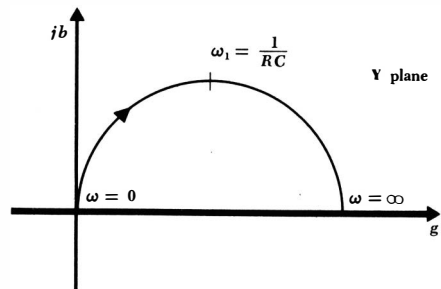

Fig. 15-4 The Y locus of a series RC circuit is a semicircle in the first quadrant.

435 Frequency Response

($-90^\circ \leq \text{ang } \mathbf{Z} \leq 0^\circ$), and the admittance locus must lie completely in the first quadrant ($0^\circ \leq \text{ang } \mathbf{Y} \leq +90^\circ$). These conclusions should be checked with the admittance locus shown in Fig. 15-4.

Analytically, the admittance of a series RC circuit is

$$\mathbf{Y}(j\omega) = \frac{1}{R + 1/j\omega C}$$

and therefore

$$g = \frac{R}{R^2 + 1/\omega^2 C^2} = \frac{\omega^2 C^2 R}{1 + \omega^2 C^2 R^2} \quad (15-1)$$

$$b = \frac{1/\omega C}{R^2 + 1/\omega^2 C^2} = \frac{\omega C}{1 + \omega^2 C^2 R^2} \quad (15-2)$$

The analytical expression for the curve or locus is obtained by eliminating ω between these two equations. Dividing Eq. (15-1) by (15-2) and solving for ω ,

$$\omega = \frac{g}{bRC} \quad (15-3)$$

we substitute the result into the first equation,

$$g = \frac{g^2}{Rb^2 + Rg^2}$$

simplify, and complete the square:

$$\left(g - \frac{1}{2R}\right)^2 + b^2 = \left(\frac{1}{2R}\right)^2$$

The result is an equation of a circle with center at $(1/2R, 0)$ and radius $1/2R$. The locus is not the full circle, however, for Eq. (15-3) shows that g and b must have the same sign; besides, we already decided that the locus must lie in the first quadrant. The admittance locus of the series RC circuit is therefore the semicircle shown in Fig. 15-4.

Since the impedance locus of the series RC circuit, a semi-infinite straight line, transforms into an admittance locus which is a semicircle, we should logically ask whether an infinite straight line will transform into a full circle. As a specific example, the admittance locus of the parallel RLC circuit is such an infinite straight line; is the impedance locus of this network a full circle? It should not require much thought to determine that it is. The half of the straight line extending downward from the real axis will certainly transform into a semicircle in the first quadrant, and a symmetry argument is sufficient to show that the upper half of the straight line will transform into a semicircle in the fourth quadrant. Both the impedance locus and admittance locus for this parallel RLC circuit are shown in Fig. 15-5.

The general subject to which this example serves as an introduction is called the *mapping* of functions of a complex variable. Given a locus in one complex plane, what form does the locus take when it is mapped onto another complex plane which has a specific functional relationship to the first complex plane?

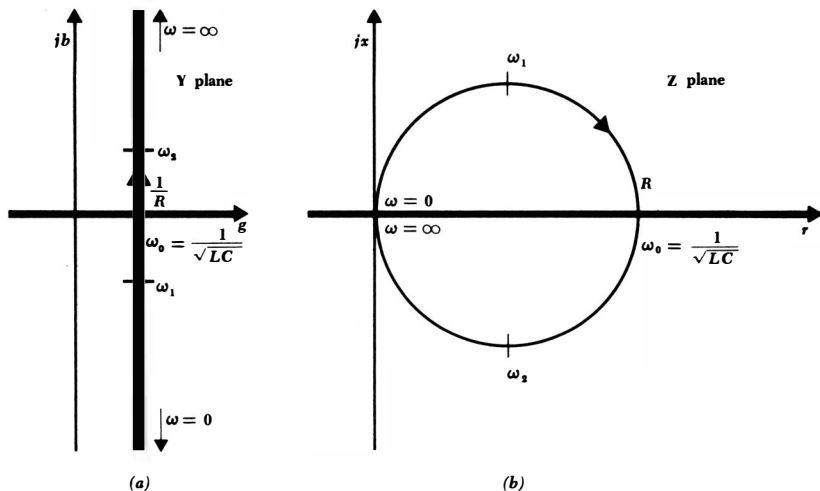

Fig. 15-5 (a) The admittance locus of a parallel RLC circuit. (b) The impedance locus of this same circuit.

In our example, $Z = 1/Y$ is the functional relationship between the two planes. One of the theorems of this branch of mathematics states that circles always map into circles if the two planes are related by a general bilinear transformation. In stating this theorem, it is understood that an infinite straight line is to be interpreted as a circle having an infinite radius with a center at infinity. Furthermore, the general bilinear transformation, expressed in terms of our two complex functions Y and Z , is

$$Z = \frac{aY + b}{cY + d}$$

where a , b , c , and d are arbitrary complex constants. In our case, the necessary relationship between Z and Y forces us to select a and d as zero and the ratio b/c as unity.

The proof of a restricted form of this theorem for the transformation $Z = 1/Y$ is outlined and left for completion as Prob. 3 at the end of this chapter. The statement to be proved is that any circle in one plane with its center on the real axis maps into a circle in the other plane, also centered on the real axis, under the transformation $Z = 1/Y$. A corollary of this theorem is then proved; it states that a *vertical* straight line will map into a circle with center on the real axis and passing through the origin. If we have to map a semi-infinite straight line, it is apparent that we shall obtain a semicircle. We shall consider an example of the use of these mapping theorems as the first topic in the following section.

Drill Problems

15-1 Sketch the impedance locus of each two-element network described below and determine the frequency at which $\text{ang } \mathbf{Z}$ is $\pm 45^\circ$:
(a) 5 ohms and 2 henrys in parallel; **(b)** 20 ohms and 0.01 farad in series; **(c)** 20 ohms and 0.01 farad in parallel.

Ans. 5 radians/sec; 2.5 radians/sec; 5 radians/sec

15-2 Sketch the admittance locus of each two-element network described below and determine the frequency at which $\text{ang } \mathbf{Y} = \pm 45^\circ$: **(a)** 5 ohms and 2 henrys in series; **(b)** 5 ohms and 2 henrys in parallel; **(c)** 20 ohms and 0.01 farad in series.

Ans. 5 radians/sec; 2.5 radians/sec; 2.5 radians/sec

15-3 A parallel RLC circuit contains the following element values: $R = 1$ ohm, $L = 1$ henry, $C = 1$ farad. Suppose that the circular impedance locus has a radius of 1 in. Determine the (shorter) arc length in inches between the point at which: **(a)** $\omega = 1$ and $\omega = 2$; **(b)** $\omega = 2$ and $\omega = 3$; **(c)** $\omega = 10$ and $\omega = 11$.

Ans. 0.0185 in.; 0.459 in.; 1.964 in.

15-3 FURTHER CONSIDERATIONS OF IMMITTANCE LOCI

Let us use the mapping theorems introduced in the previous section, as well as the knowledge we can obtain from the complex-frequency plane, to obtain loci on the \mathbf{Z} plane and \mathbf{Y} plane for the specific series RLC circuit shown in Fig. 15-6a. Since

$$\mathbf{Z}(s) = 4 + 2s + \frac{20}{s}$$

and
$$\mathbf{Z}(j\omega) = 4 + j\left(2\omega - \frac{20}{\omega}\right)$$

the impedance locus will obviously have a constant real part and will thus be a straight line. Specifically, we have

$$r = 4 \quad x = 2\omega - \frac{20}{\omega}$$

The \mathbf{Z} locus must therefore be an infinite vertical straight line, passing through the r axis at $r = 4$. The locus is shown in Fig. 15-6b. Several interesting frequencies may be specifically indicated, such as that occurring when the real axis is crossed (the resonant frequency ω_0) and the two frequencies (the half-power frequencies ω_1 and ω_2) at which the phase angle is $\pm 45^\circ$. Although these frequencies will be determined by general formulas later, and although

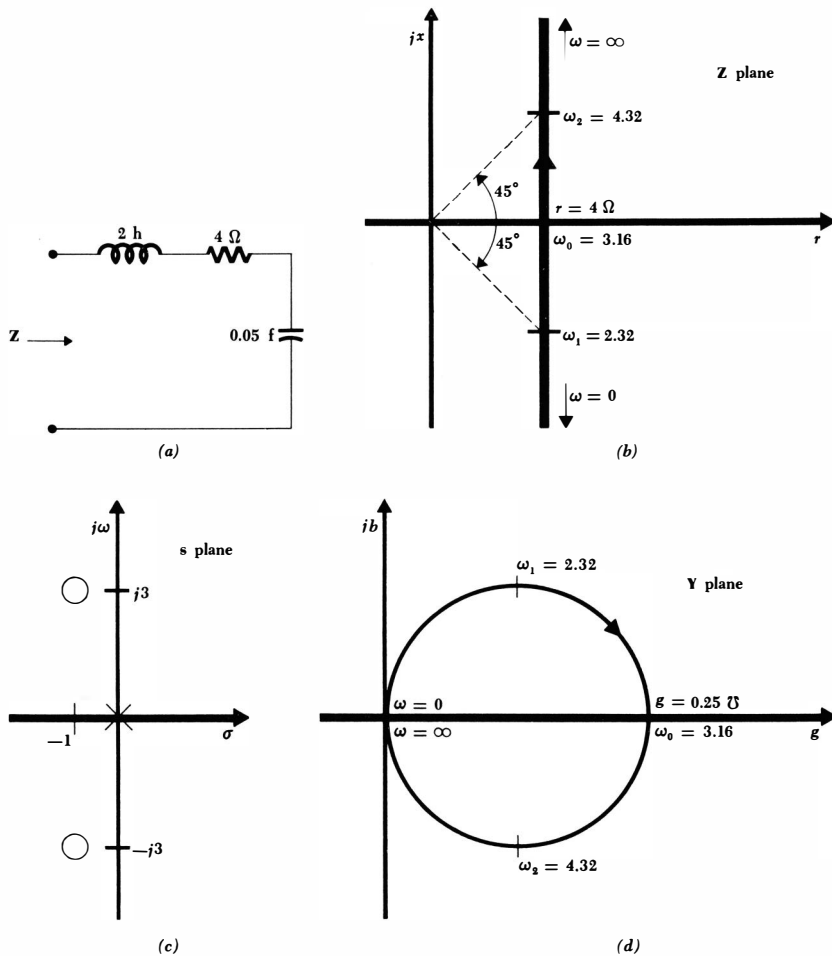

Fig. 15-6 (a) A series RLC circuit used as an example. (b) The Z locus of this circuit. (c) The pole-zero configuration on the s plane. (d) The corresponding Y locus.

they might be obtained by manipulating the expressions for r and x algebraically, let us instead obtain as much of this information as we can from an inspection of the pole-zero constellation in the s plane. In factored form $Z(s)$ becomes

$$Z(s) = 2 \frac{(s + 1 + j3)(s + 1 - j3)}{s}$$

The two zeros and the single pole are indicated on the s plane, as shown in Fig. 15-6c.

Let us try to estimate the position of the point on the $j\omega$ axis which corresponds to the resonant frequency by examining the pole-zero constellation. The impedance angle must be zero at this frequency. Hence if we draw vectors from the pole and the two zeros to the proposed point, the sum of the two zero-vector angles must be equal to the pole-vector angle (measured relative to the σ axis, of course). Considering only positive values of ω , this obviously (?) must occur near $\omega = 3$; a more careful inspection shows that the angle of the vector from the upper zero must be slightly positive, and thus a resonant frequency slightly greater than $\omega = 3$ is indicated. The exact value is $\omega_0 = 3.16$. An impedance phase angle of -45° is our next goal. Since the phase angle is almost -90° for very small values of ω , and 0° at resonance, a -45° phase angle must occur somewhere between $\omega = 0$ and $\omega_0 = 3.16$. Furthermore, the angle from the pole is 90° , the angle from the lower zero looks like about 80° , and therefore the angle from the upper zero must be approximately -35° . Now the upper vector must have an angle of -45° at $\omega = 2$, and thus ω_1 must be slightly larger than 2; the exact value is 2.32. By similar arguments, an estimate may be made for ω_2 as slightly larger than $\omega = 4$; the exact value is 4.32. These values are marked on the impedance locus of Fig. 15-6b.

Now let us apply the mapping theorem from the previous section. The impedance locus is a vertical infinite straight line, and the admittance locus is therefore a full circle, center on the real axis and passing through the origin. Since the *minimum* value of the impedance is 4 ohms, the *maximum* value of the admittance is 0.25 mho. The two extremities of the circle on the real axis are thus located, the origin and $g = 0.25$. The circle is now easily sketched, and the three interesting frequencies are indicated on it in Fig. 15-6d.

We have now constructed the loci of most of the simple RL , RC , and RLC circuits, and we should look at more complicated circuits. As an example of one simple class of networks which contain any number of resistors but only one energy-storage element, let us consider the network shown in Fig. 15-7a. The admittance locus may be obtained in several different ways. We could obtain the expression for $Y(j\omega)$ and evaluate it at a sufficient number of points to draw a smooth locus, or we could determine both $g(j\omega)$ and $b(j\omega)$, eliminate ω , and try to recognize the resultant equation through a familiarity with analytic geometry. Both these methods require too much work and defeat one of the purposes of loci construction, the collection of maximum information with minimum labor. Instead, let us build up the finished locus in gradual steps, beginning with the energy-storage element and the resistor with which it is in parallel. The Y locus of this parallel RC network is familiar, and it is drawn in Fig. 15-7b. Also shown next to it is the corresponding Z locus. In building up the given network, we must next include a series 4-ohm resistor. Since impedances add directly, the Z locus of this new network must be the Z locus of the parallel RC network with *every point shifted to the right by 4 ohms*. This partial network, its Z locus, and the corresponding Y locus

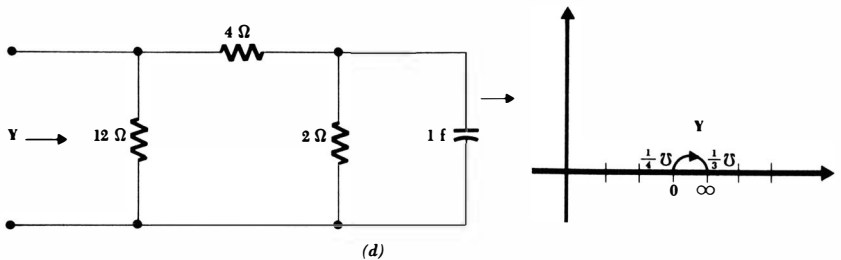
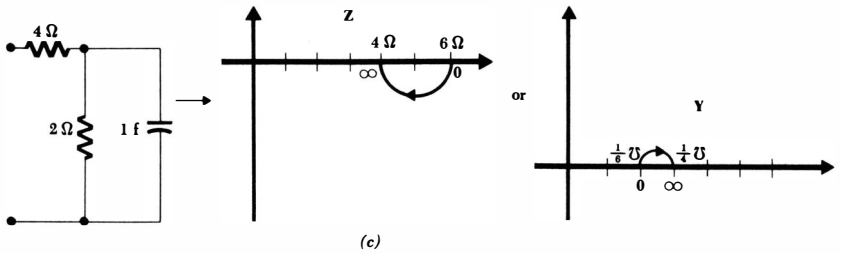
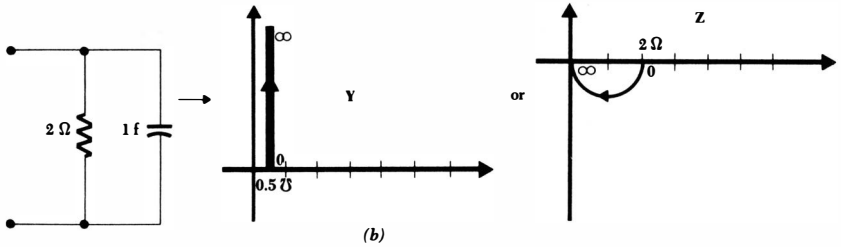
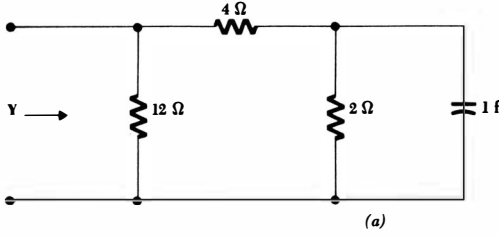

Fig. 15-7 (a) A given capacitive network. (b) The Z locus and Y locus of the elementary portion of the network containing the reactive element. (c) The series addition of a 4-ohm resistor shifts the Z locus to the right by 4 ohms; the corresponding Y locus is also shown. (d) The parallel 12-ohm resistor shifts the Y locus $\frac{1}{12}$ mho to the right; this is the desired result.

are shown in Fig. 15-7*c*. The final step requires a 12-ohm resistor to be combined in parallel; thus, a conductance of $\frac{1}{2}$ mho is added to the entire \mathbf{Y} locus of Fig. 15-7*c*. The final \mathbf{Y} locus is therefore that shown in Fig. 15-7*d*.

In retrospect, is there any simpler method by which this locus might now be obtained? The method whereby we constructed the locus should suggest that the final locus must be a semicircle if only one energy-storage element is present, for the locus of the initially used portion of the network can be no more complicated than a semicircle, and "circles transform into circles." Adding a constant resistance or conductance merely shifts the locus along the real axis. This initial assumption of a semicircular locus, centered on the real axis and lying entirely in the first or fourth quadrant, does simplify the construction. We merely need to determine the maximum and minimum values of the admittance (or impedance), decide whether the locus is in the first or fourth quadrant, and draw the semicircle. In the example above, the maximum admittance must occur when X_C is zero, or at infinite frequency. Replacing the capacitor by a short circuit, we find that $\mathbf{Y} = \frac{1}{3}$ mho. The minimum admittance occurs at $\omega = 0$ and is $\mathbf{Y} = \frac{1}{4}$ mho. Since the network is capacitive, the admittance phase angle is positive, and the final locus shown in Fig. 15-7*d* can be drawn quite quickly.

This method is applicable in general to any network containing either a single capacitor or a single inductor; it is of course also applicable to networks containing several capacitors or inductors that may be combined into a single equivalent element.

We may also extend this technique to include any network containing one inductor and one capacitor in series or one inductor and one capacitor in parallel. The locus will be a full circle, centered on the real axis. As an example, the network shown in Fig. 15-8*a* contains a series LC network. The minimum impedance occurs when the impedance of the LC arm is a minimum. By inspection, this impedance is zero at $\omega = 1$, and the input impedance is then 3 ohms. The maximum impedance occurs when the impedance of the LC arm is a maximum, at $\omega = 0$ or ∞ , and this maximum impedance is 7 ohms. With two points on the real axis known, the circular locus may be drawn very easily, Fig. 15-8*b*. The direction of travel on the locus as frequency increases may be determined by considering a frequency close to zero. There the inductive impedance is very small and the network must look capacitive; the phase angle is therefore negative, and the locus swings down into the fourth quadrant as it leaves the point at which $\omega = 0$.

Problem 13 at the end of this chapter is built around several networks for which careless inspection might indicate the presence of series or parallel LC arms. Neither is present, however, and the loci are *not* circles.

There are very few other networks for which loci of simple geometrical forms are applicable. As a rule it will be necessary to perform a few more calculations for more involved networks. Let us consider the single example indicated in Fig. 15-9*a*. We may think of this network as the parallel combination of a series RL network and a parallel RC network, both of which individually possess simple admittance loci. The desired admittance locus is the sum of these two

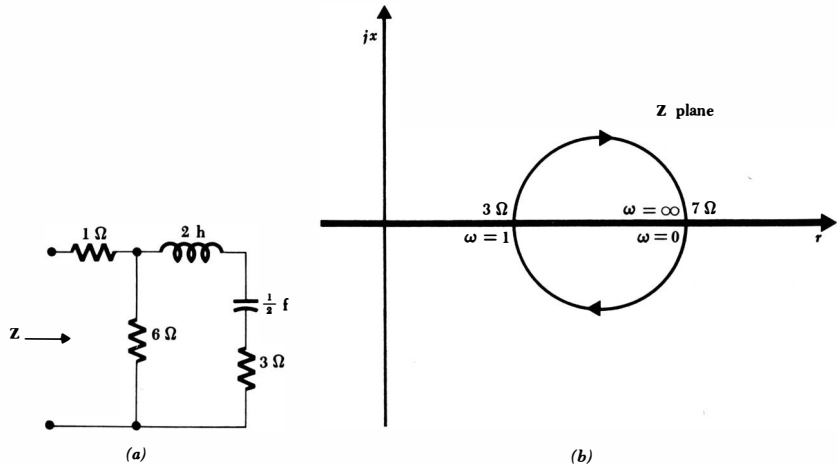

Fig. 15-8 (a) A given network which contains a single LC series arm. (b) The resultant circular impedance locus.

simpler loci, but the sum must be obtained by adding admittance values point by point at corresponding frequencies. It is thus necessary to identify a number of frequencies accurately on both of the simpler loci, as shown in Fig. 15-9*b* and *c*. The desired locus may now be obtained by adding the admittances of the two subnetworks at corresponding frequencies. Graphical addition is fairly rapid but somewhat inaccurate; it is certainly sufficient for qualitative results. The desired locus shown in Fig. 15-9*d* was obtained by numerically evaluating the input admittance at $\omega = 1, 2, 3, 4,$ and 5 .

It is important to note that the shape of a locus which must be obtained by combining corresponding points of two partial loci is very sensitive to the size of the energy-storage elements. For example, if the capacitor is increased by a factor of 10 (from 0.5 to 5 farads), then each of the marked frequencies on the locus of Fig. 15-9*c* must be replaced with a frequency one-tenth as large. In obtaining the locus of the complete network by combining corresponding points, it is apparent that the contribution from the locus of the capacitive arm is now the more dominant at the lower frequencies. This shows up in the completed locus of Fig. 15-10*a*. On the other hand, if the capacitor is replaced with one having a capacitance of $\frac{1}{20}$ farad, the locus of Fig. 15-10*b* is obtained. This is the drawing that a ten-year-old might produce if told to "add the two pictures" of Fig. 15-9*b* and *c*.

Some of the information we have just absorbed about impedance loci and admittance loci is also applicable to loci which display a transfer impedance, transfer admittance, voltage gain, or current gain. The locus may represent the ratio of a current or voltage at one point in a circuit to a current or voltage at any other point in the circuit. We should not conclude that the locus of the

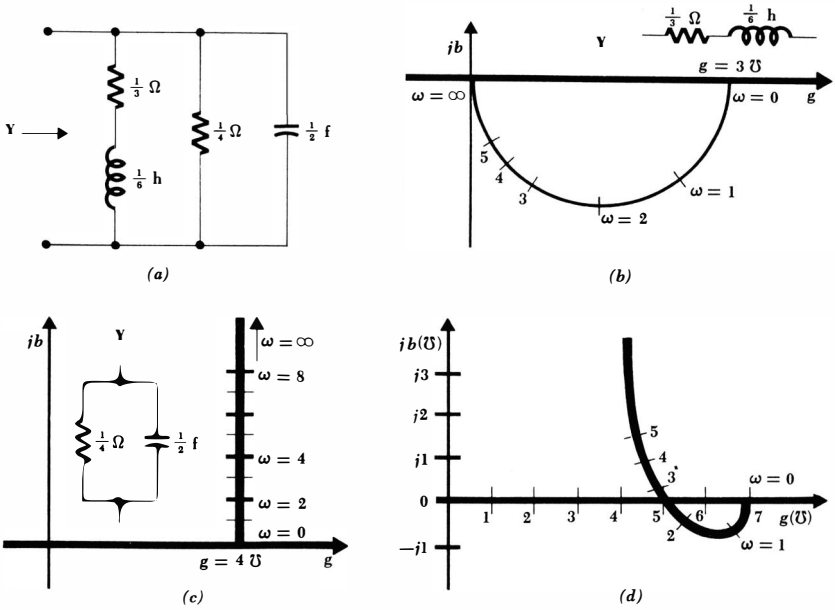
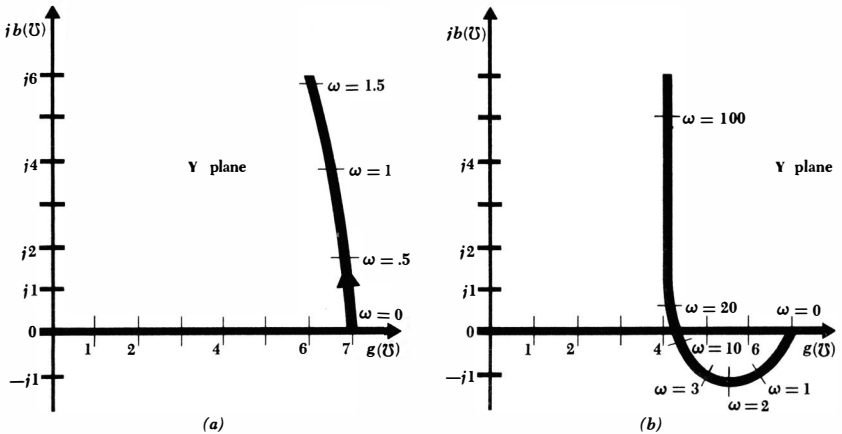

Fig. 15-9 (a) A given RLC network. (b) The Y locus of the series RL subnetwork. (c) The Y locus of the parallel RC subnetwork. (d) The Y locus of the complete network may be obtained by point-by-point addition of the subloci.

Fig. 15-10 The locus shown in Fig. 15-9d for the network of Fig. 15-9a changes markedly as either reactive element changes. The locus shown as (a) applies for $C = 5$ farads, and that in (b) for $C = 0.05$ farad.



ratio of the output voltage to the input voltage of any network containing only one energy-storage element must be a semicircle centered on the real axis, but instead we should write down the voltage gain as a function of $j\omega$ and inspect it carefully to determine whether a straight-line locus may be applicable. It is also possible that the *reciprocal* of the gain function will provide a straight-line locus, and if such is the case, we may then make use of the mapping theorem presented in the previous section. The opportunity to try out our skill on such loci is made available in a number of the problems at the end of this chapter.

Before leaving the subject of loci, we should also note that it is not necessary that frequency be the parameter whose variation leads to a locus in a complex plane. It may also be desirable to obtain the locus *at a constant frequency* as some single element in the network varies. Loci for these *adjustable* networks are not difficult to construct; several examples are offered in the problems.

Drill Problems

15-4 For the network shown in Fig. 15-11a, show that the Z locus is a semicircle, construct the locus, and determine the radius (in ohms) of the semicircle if: (a) $R = 2$ ohms; (b) $R = 10$ ohms; (c) $R = 50$ ohms.

Ans. 0.83 ohm; 2.5 ohms; 4.17 ohms

15-5 For the network shown in Fig. 15-11a, show that the Y locus is a semicircle, construct the locus, and determine the radius (in mhos) of the semicircle if: (a) $R = 2$ ohms; (b) $R = 10$ ohms; (c) $R = 50$ ohms.

Ans. 4.83 mmhos; 19.8 mmhos; 52.5 mmhos

15-6 For the network shown in Fig. 15-11b, construct the Z locus and then determine the maximum value of the *input reactance* if: (a) $R = 1$ ohm; (b) $R = 10$ ohms; (c) $R = 100$ ohms.

Ans. 0.5 ohm; 5 ohms; 50 ohms

Fig. 15-11 (a) See Drill Probs. 15-4 and 15-5. (b) See Drill Probs. 15-6 and 15-7. (c) See Drill Prob. 15-8.

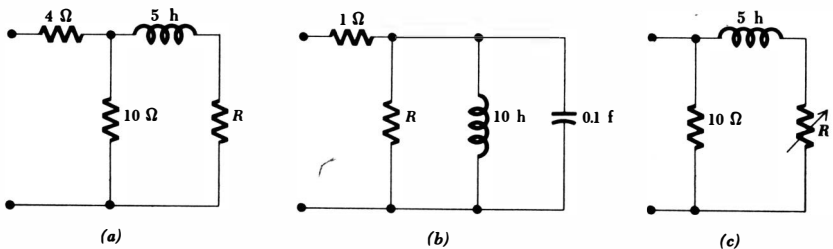

15-7 By graphical methods, determine the minimum value of the phase angle of the input admittance of the network shown in Fig. 15-11*b* if: (a) $R = 1$ ohm; (b) $R = 10$ ohms; (c) $R = 100$ ohms.

Ans. -20° ; -56° ; -79°

15-8 Draw the Y locus of the network shown in Fig. 15-11*c* at $\omega = 2$ as R is adjusted continuously from 0 to ∞ ohms. From the resultant locus determine: (a) $|Y|_{\min}$; (b) $|G_{\text{in}}|_{\max}$; (c) $|B_{\text{in}}|_{\max}$.

Ans. 0.1 mho; 0.1 mho; 0.15 mho

15-4 PARALLEL RESONANCE

In this section we shall begin the study of a very important phenomenon which may occur in circuits containing both inductors and capacitors. The phenomenon is called resonance, and it may be loosely described as the condition existing in any physical system when a fixed-amplitude sinusoidal forcing function produces a response of maximum amplitude. However, we often speak of resonance as occurring even when the forcing function is not sinusoidal. The resonant system may be electrical, mechanical, hydraulic, acoustic, or some other kind, but we shall restrict our attention to electrical systems. We shall define resonance more exactly below.

Resonance is a familiar phenomenon. By jumping up and down on the bumper of an automobile, for example, the vehicle can be put into rather large oscillatory motion if the jumping is done *at the proper frequency* (about one jump per second), and if the shock absorbers are somewhat decrepit. However, if the jumping frequency is increased or decreased, the vibrational response of the automobile will be considerably less than it was before. A further illustration is furnished in the case of an opera singer who is able to shatter crystal goblets by means of a well-formed note *at the proper frequency*. In each of these examples, we are thinking of frequency as being adjusted until resonance occurs; it is also possible to adjust the size, shape, and material of the mechanical object being vibrated, but this may not be so easily accomplished physically.

The condition of resonance may or may not be desirable, depending upon the purpose which the physical system is to serve. In the automotive example above, a large amplitude of vibration may help to separate locked bumpers, but it would be somewhat disagreeable at 60 miles an hour.

Let us now define resonance more carefully. In a two-terminal electrical network containing at least one inductor and one capacitor, *resonance* is the condition which exists when the input impedance of the network is purely resistive. Thus, a network is said to be in resonance when the voltage and current at the network input terminals are in phase. We shall also find that a maximum-amplitude response is produced in the network when it is in the resonant condition or *almost in the resonant condition*.

Fig. 15-12 The parallel combination of a resistor, an inductor, and a capacitor, often referred to as a parallel resonant circuit.

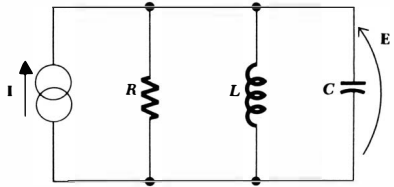

We shall apply the definition of resonance to the parallel RLC network shown in Fig. 15-12. In many practical situations, this circuit is a very good approximation to the circuit we might build in the laboratory by connecting a physical inductor in parallel with a physical capacitor, where this parallel combination is driven by an energy source having a very high output impedance. The admittance offered to the ideal current source is

$$\mathbf{Y} = \frac{1}{R} + j\left(\omega C - \frac{1}{\omega L}\right) \quad (15-4)$$

and thus resonance occurs when

$$\omega C - \frac{1}{\omega L} = 0$$

The resonant condition may be achieved by adjusting L , C , or ω ; we shall devote our attention to the case for which ω is the variable. Hence, the resonant frequency ω_0 is

$$\omega_0 = \frac{1}{\sqrt{LC}} \quad (15-5)$$

or
$$f_0 = \frac{1}{2\pi\sqrt{LC}} \quad (15-6)$$

The pole-zero configuration of the admittance function can also be used to considerable advantage here. Given $\mathbf{Y}(s)$,

$$\mathbf{Y}(s) = \frac{1}{R} + \frac{1}{Ls} + Cs$$

or
$$\mathbf{Y}(s) = C \frac{s^2 + s/RC + 1/LC}{s} \quad (15-7)$$

we may display the zeros of $\mathbf{Y}(s)$ by factoring the numerator,

$$\mathbf{Y}(s) = C \frac{(s + \alpha - j\omega_d)(s + \alpha + j\omega_d)}{s}$$

where α and ω_d represent the same quantities that they did when we discussed the natural response of the parallel RLC circuit in Sec. 8-2. That is, α is the exponential damping coefficient,

$$\alpha = \frac{1}{2RC}$$

447 **Frequency Response**

and ω_d is the natural resonant frequency (not the resonant frequency ω_0),

$$\omega_d = \sqrt{\omega_0^2 - \alpha^2}$$

The pole-zero constellation shown in Fig. 15-13a follows directly from the factored form.

In view of the relationship among α , ω_d , and ω_0 , it is apparent that the distance from the origin of the s plane to one of the admittance zeros is numerically equal to ω_0 . Given the pole-zero configuration, the resonant frequency may therefore be obtained by purely graphical methods. We merely swing an arc, using the origin of the s plane as a center, through one of the zeros. The intersection of this arc and the positive $j\omega$ axis locates the point $s = j\omega_0$. It is evident that ω_0 is slightly greater than the natural resonant frequency ω_d , but their ratio approaches unity as the ratio of ω_d to α increases.

Next let us examine the magnitude of the response, the voltage $E(s)$ indicated in Fig. 15-12, as the frequency of the forcing function is varied. If we assume a constant-amplitude sinusoidal current source, the voltage response is proportional to the input impedance. This response can therefore be obtained from the pole-zero plot of the impedance $Z(s)$, shown in Fig. 15-13b. The response obviously starts at zero, reaches a maximum value in the vicinity of the natural resonant frequency, and then drops again to zero as ω becomes infinite. The frequency response is sketched in Fig. 15-14. The maximum value of the response is indicated as R times the amplitude of the source current, implying that the maximum value of the circuit impedance is simply R ohms; moreover, the response maximum is shown to occur *exactly* at the resonant frequency ω_0 . The two frequencies ω_1 and ω_2 , which we shall see later will give us a measure of the width of the response curve, are also identified. Let us first show that the maximum impedance is R ohms and that this maximum impedance occurs at resonance.

The admittance, as specified by Eq. (15-4), possesses a constant conductance and a susceptance which has a minimum magnitude (zero) at resonance. The

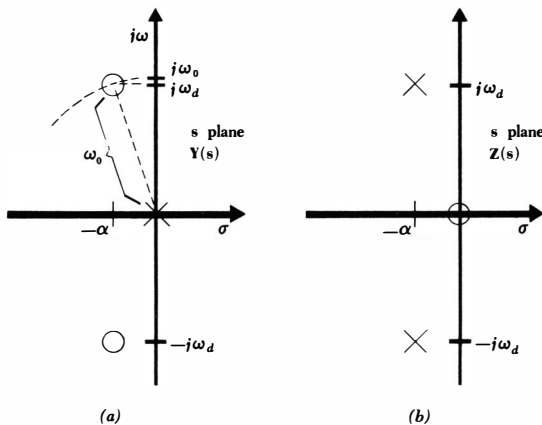

Fig. 15-13 (a) The pole-zero constellation of the input admittance of a parallel resonant circuit is shown on the s plane. The relationship between α , ω_d , and ω_0 is apparent. (b) The pole-zero constellation of the input impedance.

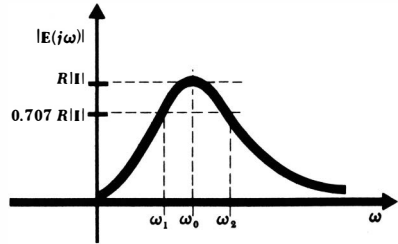

Fig. 15-14 The magnitude of the voltage response of a parallel resonant circuit is shown as a function of frequency.

minimum admittance magnitude therefore occurs at resonance, and it is $1/R$ mhos. Hence, the maximum impedance magnitude is R ohms, and it occurs at resonance.

The maximum value of the response magnitude and the frequency at which it occurs are not always found so easily. In less standard resonant circuits, we may find it necessary to express the magnitude of the response in analytical form, usually as the square root of the sum of the real part squared and the imaginary part squared; then we should differentiate this expression with respect to frequency, equate the derivative to zero, solve for the frequency of maximum response, and finally substitute this frequency into the magnitude expression to obtain the maximum-amplitude response. This procedure may be carried out for this simple case merely as a corroborative exercise, but as we have seen, it is not necessary.

It should be emphasized that, although the height of the response curve of Fig. 15-14 depends only upon the value of R for constant-amplitude excitation, the width of the curve or the steepness of the sides depends upon the other two element values also. We shall shortly relate the "width of the response curve" to a more carefully defined quantity, the bandwidth, but it will be helpful to express this relationship in terms of a very important parameter, the *quality factor* Q .

We shall find that the sharpness of the response curve of any resonant circuit is determined by the maximum amount of energy that can be stored in the circuit, compared with the energy that is lost during one complete period of the response. We define Q as

$$Q = 2\pi \frac{\text{maximum energy stored}}{\text{total energy lost per period}} \quad (15-8)$$

The proportionality constant 2π is included in the definition in order to simplify the more useful expressions for Q which we shall now obtain. Since energy can be stored only in the inductor and the capacitor, and can be lost only in the resistor, we may express Q in terms of the instantaneous energy associated with each of the reactive elements and the average power dissipated in the resistor:

$$Q = 2\pi \frac{(W_L + W_C)_{\max}}{P_R T}$$

Now let us apply this definition to the parallel RLC circuit and determine the value of Q at the resonant frequency. This value of Q is denoted by Q_0 .

449 Frequency Response

We select the current forcing function

$$i(t) = I_m \cos \omega_0 t$$

and obtain the corresponding voltage response at resonance,

$$e(t) = Ri(t) = RI_m \cos \omega_0 t$$

Then the energy stored in the capacitor is

$$W_C = \frac{1}{2} C e^2 = \frac{I_m^2 R^2 C}{2} \cos^2 \omega_0 t$$

The instantaneous energy stored in the inductor becomes

$$W_L = \frac{1}{2} L i^2 = \frac{1}{2} L \left(\frac{1}{L} \int_0^t e \, dt \right)^2$$

Thus

$$W_L = \frac{I_m^2 R^2 C}{2} \sin^2 \omega_0 t$$

The total *instantaneous* stored energy is therefore constant

$$W = W_L + W_C = \frac{I_m^2 R^2 C}{2}$$

and this constant value must also be the maximum value. In order to find the energy lost in the resistor in one period, we take the average power absorbed by the resistor,

$$P_R = \frac{1}{2} I_m^2 R$$

and multiply by one period, obtaining

$$P_R T = \frac{1}{2 f_0} I_m^2 R$$

We thus find the quality factor at resonance:

$$Q_0 = 2\pi \frac{I_m^2 R^2 C / 2}{I_m^2 R / 2 f_0}$$

$$\text{or} \quad Q_0 = 2\pi f_0 RC = \omega_0 RC \quad (15-9)$$

Equivalent expressions for Q_0 which are often quite useful may be obtained by simple substitution:

$$Q_0 = R \sqrt{\frac{C}{L}} = \frac{R}{X_{C0}} = \frac{R}{X_{L0}} \quad (15-10)$$

It is apparent that Q_0 is a dimensionless constant which is a function of all three circuit elements in the parallel resonant circuit. The concept of Q , however, is not limited to electric circuits or even to electrical systems; it is useful in describing any resonant phenomenon. For example, let us consider a bouncing golf ball. If we assume a weight of W newtons and release the golf ball from a height of h_1 meters above a very hard (lossless) horizontal surface, then

450 Complex Frequency

the ball rebounds to some lesser height h_2 . The energy stored initially is Wh_1 , and the energy lost in one period is $W(h_1 - h_2)$. The Q_0 is therefore

$$Q_0 = 2\pi \frac{h_1 W}{(h_1 - h_2)W} = \frac{2\pi h_1}{h_1 - h_2}$$

A perfect golf ball would rebound to its original height and have an infinite Q_0 ; a more typical value is 35. It should be noted that the Q in this mechanical example has been calculated from the natural response and not from the forced response. The Q of an electric circuit may also be determined from a knowledge of the natural response, as illustrated by Probs. 31 and 32.

Let us now relate the various parameters which we have associated with a parallel resonant circuit. The three parameters α , ω_d , and ω_0 were introduced much earlier in connection with the natural response. Resonance, by definition, is fundamentally associated with the forced response since it is defined in terms of a purely resistive input impedance, a sinusoidal steady-state concept. The two most important parameters of a resonant circuit are perhaps the resonant frequency ω_0 and the quality factor Q_0 . Both the exponential damping coefficient and the natural resonant frequency may be expressed in terms of ω_0 and Q_0 :

$$\alpha = \frac{1}{2RC} = \frac{1}{2(Q_0/\omega_0 C)C}$$

$$\text{or} \quad \alpha = \frac{\omega_0}{2Q_0} \quad (15-11)$$

$$\text{and} \quad \omega_d = \sqrt{\omega_0^2 - \alpha^2}$$

$$\text{or} \quad \omega_d = \omega_0 \sqrt{1 - \left(\frac{1}{2Q_0}\right)^2} \quad (15-12)$$

In terms of these two resonance parameters, the natural response of the parallel resonant circuit

$$e(t) = A\epsilon^{-\alpha t} \cos \omega_d t$$

becomes

$$e(t) = A\epsilon^{-(\omega_0/2Q_0)t} \cos \omega_0 \sqrt{1 - \left(\frac{1}{2Q_0}\right)^2} t$$

The three critical frequencies (of the input admittance, for example) may also be expressed in terms of ω_0 and Q_0 . We have the pole at the origin,

$$s_1 = 0$$

and the pair of conjugate complex zeros,

$$s_{2,4} = -\alpha \pm j\omega_d$$

$$\text{or} \quad s_{2,4} = -\frac{\omega_0}{2Q_0} \pm j\omega_0 \sqrt{1 - \left(\frac{1}{2Q_0}\right)^2}$$

The resonance parameters ω_0 and Q_0 may therefore be used to describe the natural response in either the time domain or the frequency domain. The knowledge provided by these same two parameters about the pole-zero constellation also leads to a further interpretation of the settling time and the oscillatory behavior of the parallel *RLC* circuit. For example, we know that the settling time, which is the time taken for the natural response to “die out,” is approximately inversely proportional to α ; to the same degree of approximation, then, the settling time is directly proportional to Q_0 . If both ω_0 and Q_0 are increased by the same factor, however, no appreciable change in settling time can occur. It is also evident that large values of Q_0 cause the natural resonant frequency and the resonant frequency to be nearly equal.

Let us now interpret Q_0 in terms of the pole-zero locations of the admittance $Y(s)$ of the parallel *RLC* circuit. We shall keep ω_0 constant; this may be done, for example, by changing R while holding L and C constant. As Q_0 is increased, the relationship between α , Q_0 , and ω_0 indicates that the two zeros must move closer to the $j\omega$ axis. The relationship between ω_d , ω_0 , and Q_0 shows that the zeros must simultaneously move away from the σ axis. The exact nature of the movement becomes clearer when we remember that the point at which $s = j\omega_0$ could be located on the $j\omega$ axis by swinging an arc, centered at the origin, through one of the zeros and over to the positive $j\omega$ axis; since ω_0 is to be held constant, the radius must be constant, and the zeros must therefore move along this arc toward the positive $j\omega$ axis as Q_0 increases. It is evident that ω_d and ω_0 are becoming more nearly equal; if Q_0 is 5, these two frequencies differ by about one-half of 1 per cent.

The “width” of the resonant response curve, such as the one shown in Fig. 15-14, may now be defined more carefully and related to Q_0 . Let us first define the two *half-power frequencies* ω_1 and ω_2 as those frequencies at which the magnitude of the input admittance of a parallel resonant circuit is greater than the magnitude at resonance by a factor of $\sqrt{2}$. Since the response curve of Fig. 15-14 displays the voltage produced across the parallel circuit by a sinusoidal current source as a function of frequency, the half-power frequencies also locate those points at which the voltage response is $1/\sqrt{2}$, or 0.707, times its maximum value. A similar relationship holds for the impedance magnitude. We shall select ω_1 as the *lower half-power frequency* and ω_2 as the *upper half-power frequency*. These names arise from the fact that a voltage which is 0.707 times the resonant voltage is equivalent to a squared voltage which is *one-half* the squared voltage at resonance.

The bandwidth of a resonant circuit is defined as the difference of these two half-power frequencies,

$$\mathfrak{B} = \omega_2 - \omega_1 \quad (15-13)$$

We think of the bandwidth as the “width” of the response curve, even though the curve actually extends from $\omega = 0$ to $\omega = \infty$. More exactly, the bandwidth is measured by that portion of the response curve which is equal to or greater than 70.7 per cent of the maximum value.

Now let us express the bandwidth \mathfrak{B} in terms of Q_0 and the resonant fre-

quency. In order to do so, we first express the admittance of the parallel *RLC* circuit,

$$Y = \frac{1}{R} + j\left(\omega C - \frac{1}{\omega L}\right)$$

in terms of Q_0 ,

$$Y = \frac{1}{R} + j\frac{1}{R}\left(\frac{\omega\omega_0 CR}{\omega_0} - \frac{\omega_0 R}{\omega\omega_0 L}\right)$$

$$\text{or } Y = \frac{1}{R} \left[1 + jQ_0 \left(\frac{\omega}{\omega_0} - \frac{\omega_0}{\omega} \right) \right] \quad (15-14)$$

We note again that the magnitude of the admittance at resonance is $1/R$, and then realize that an admittance magnitude of $\sqrt{2}/R$ can occur only when a frequency is selected such that the imaginary part of the bracketed quantity has a magnitude of unity. Thus

$$Q_0 \left(\frac{\omega_2}{\omega_0} - \frac{\omega_0}{\omega_2} \right) = 1 \quad \text{and} \quad Q_0 \left(\frac{\omega_1}{\omega_0} - \frac{\omega_0}{\omega_1} \right) = -1$$

Solving, we have

$$\omega_1 = \omega_0 \left[\sqrt{1 + \left(\frac{1}{2Q_0} \right)^2} - \frac{1}{2Q_0} \right] \quad (15-15)$$

$$\omega_2 = \omega_0 \left[\sqrt{1 + \left(\frac{1}{2Q_0} \right)^2} + \frac{1}{2Q_0} \right] \quad (15-16)$$

Although these expressions are somewhat unwieldy, their difference provides a very simple formula for the bandwidth:

$$\mathfrak{B} = \omega_2 - \omega_1 = \frac{\omega_0}{Q_0} \quad (15-17)$$

Circuits possessing a higher Q_0 have a narrower bandwidth, or a sharper response curve; they have greater *frequency selectivity*.

Many resonant circuits are deliberately designed to have a large Q_0 in order to take advantage of the narrow bandwidth and high-frequency selectivity associated with such circuits. When Q_0 is larger than about 5, it is possible to make some very useful approximations in the expressions for the upper and lower half-power frequencies and in the general expressions for the response in the neighborhood of resonance. Let us arbitrarily refer to a *high- Q* circuit as one in which Q_0 is equal to or greater than 5. The pole-zero configuration of $Y(s)$ for a parallel *RLC* circuit having a Q_0 of about 5 is shown in Fig. 15-15. Since

$$\alpha = \frac{\omega_0}{2Q_0}$$

then

$$\alpha = \frac{1}{2} \mathfrak{B}$$

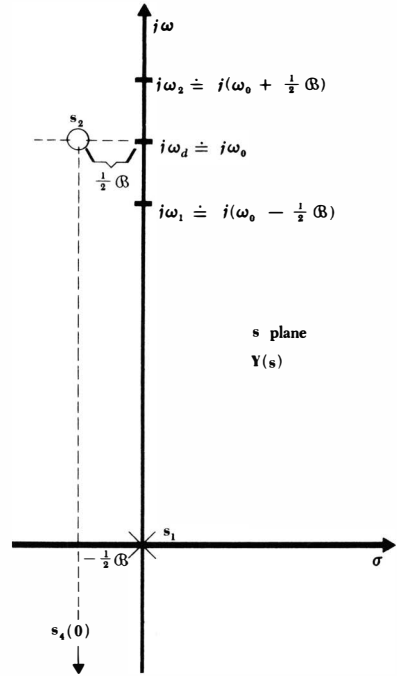

Fig. 15-15 The pole-zero configuration of $Y(s)$ for a parallel RLC circuit. The two zeros are exactly $\frac{1}{2}B$ radians/sec to the left of the $j\omega$ axis and approximately $j\omega_0$ radians/sec from the σ axis. The upper and lower half-power frequencies are separated exactly by B radians/sec, and each is approximately $\frac{1}{2}B$ radians/sec away from the resonant frequency and the natural resonant frequency.

and the locations of the two zeros may be approximated:

$$s_{2,4} \doteq -\frac{1}{2}B \pm j\omega_0$$

Moreover, the locations of the two half-power frequencies (on the positive $j\omega$ axis) may also be determined in a concise approximate form:

$$\omega_{1,2} = \omega_0 \left[\sqrt{1 + \left(\frac{1}{2Q_0}\right)^2} \mp \frac{1}{2Q_0} \right] \doteq \omega_0 \left(1 \mp \frac{1}{2Q_0} \right)$$

or
$$\omega_{1,2} = \omega_0 \mp \frac{1}{2}B \tag{15-18}$$

In a high- Q circuit, therefore, each half-power frequency is located approximately one-half bandwidth from the resonant frequency; this is indicated in Fig. 15-15.

Now let us visualize a test point slightly above $j\omega_0$ on the $j\omega$ axis. In order to determine the admittance offered by the parallel RLC network at this frequency, we construct the three vectors from the critical frequencies to the test point. If the test point is close to $j\omega_0$, then the vector from the pole is approximately $j\omega_0$ and that from the lower zero is nearly $j2\omega_0$. The admittance is therefore given approximately by

$$Y(s) \doteq C \frac{(j2\omega_0)(s - s_2)}{j\omega_0} \doteq 2C(s - s_2) \tag{15-19}$$

454 Complex Frequency

where the multiplicative constant C is determined from Eq. (15-7). In order to determine a useful approximation for the vector $(s - s_2)$, let us consider an enlarged view of that portion of the s plane in the neighborhood of the zero s_2 (Fig. 15-16). We define the angle of the admittance as θ_Y ,

$$\theta_Y = \text{ang } \mathbf{Y}$$

and note from Eq. (15-19) that θ_Y may also be identified approximately as the angle of $s - s_2$. Thus

$$s - s_2 \doteq \frac{1}{2}\mathfrak{B} + j\frac{1}{2}\mathfrak{B} \tan \theta_Y \doteq \frac{1}{2}\mathfrak{B}(1 + j \tan \theta_Y)$$

or
$$s - s_2 \doteq \frac{1}{2}\mathfrak{B} \sqrt{1 + \tan^2 \theta_Y} / \theta_Y$$

Finally

$$\mathbf{Y}(s) \doteq 2C \frac{1}{2}\mathfrak{B} \sqrt{1 + \tan^2 \theta_Y} / \theta_Y$$

or
$$\mathbf{Y}(s) \doteq \frac{1}{R} \sqrt{1 + \tan^2 \theta_Y} / \theta_Y \quad (15-20)$$

where

$$\theta_Y \doteq \tan^{-1} \frac{\omega - \omega_0}{\frac{1}{2}\mathfrak{B}} \quad (15-21)$$

Thus, the angle of the admittance at a given frequency near resonance is obtained by calculating the number of half bandwidths by which the frequency is off resonance and then taking the inverse tangent of this number, being careful to preserve the algebraic sign. The magnitude of the admittance at this frequency is given approximately by the product of the conductance $1/R$ and the square root of one plus the square of the number of half bandwidths off resonance.

As an example of the use of these approximations, let us determine the approximate value of the admittance of a parallel RLC network for which $R = 25$ ohms, $L = 1$ henry, and $C = \frac{1}{25}$ farad. We find that $Q_0 = 5$, $\omega_0 = 5$, $\mathfrak{B} = 1$, and $\mathfrak{B}/2 = 0.5$. Let us evaluate the admittance at $\omega = 5.25$, a frequency which is one-half of a half bandwidth above resonance. Thus,

$$\theta_Y \doteq \tan^{-1} (0.5) = 26.6^\circ$$

and
$$\mathbf{Y}(j5.25) \doteq 0.04 \sqrt{1 + (0.5)^2} / 26.6^\circ \doteq 0.0447 / 26.6^\circ$$

An exact calculation of the admittance shows that

$$\mathbf{Y}(j5.25) = 0.0445 / 26.0^\circ$$

The approximate method therefore leads to values of admittance magnitude and angle that are too high by about 0.5 and 2 per cent, respectively.

Our intention is to use these approximations for high- Q circuits near resonance. We have already agreed that we shall let "high- Q " infer $Q_0 \geq 5$, but how near is "near"? It can be shown that the error in magnitude or phase is less than 5 per cent if $Q_0 \geq 5$ and $0.9\omega_0 \leq \omega \leq 1.1\omega_0$. Although this narrow band of frequencies may seem to be prohibitively small, it is usually more than sufficient to contain the band of frequencies in which we are most interested.

Fig. 15-16 An enlarged portion of the pole-zero constellation for $Y(s)$ of a high- Q_0 parallel RLC circuit.

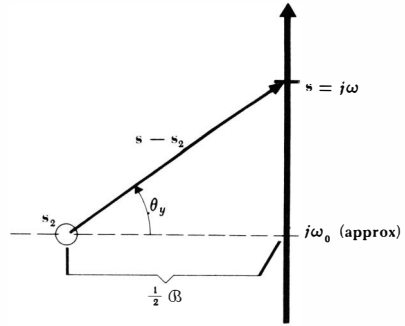

For example, a home radio may contain a circuit tuned to a resonant frequency of 455 kc with a half-power bandwidth of 10 kc. This circuit must then have a value of 45.5 for Q_0 , and the half-power frequencies are about 450 and 460 kc. Our approximations, however, are valid from 409.5 to 500.5 kc (with errors less than 5 per cent), a range which covers essentially all the peaked portion of the response curve; only in the remote “tails” of the response curve do the approximations lead to reasonably large errors.²

Let us conclude our coverage of the parallel resonant circuit by reviewing the various conclusions we have reached. The resonant frequency ω_0 is the frequency at which the imaginary part of the input admittance becomes zero or the admittance angle θ_Y becomes zero. Then, $\omega_0 = 1/\sqrt{LC}$. The circuit’s figure of merit Q_0 is defined as 2π times the ratio of the maximum energy stored in the circuit to the energy lost each period in the circuit. From this definition, we find that $Q_0 = \omega_0 RC$. The two half-power frequencies ω_1 and ω_2 are defined as the frequencies at which the admittance magnitude is $\sqrt{2}$ times the minimum admittance magnitude. These are also the frequencies at which the voltage response is 70.7 per cent of the maximum response. The exact and approximate (for high Q_0) expressions for these two frequencies are

$$\omega_{1,2} = \omega_0 \left[\sqrt{1 + \left(\frac{1}{2Q_0}\right)^2} \mp \frac{1}{2Q_0} \right] \doteq \omega_0 \mp \frac{1}{2} \mathfrak{B}$$

where \mathfrak{B} is the difference between the upper and the lower half-power frequencies. This half-power bandwidth is given by

$$\mathfrak{B} = \omega_2 - \omega_1 = \frac{\omega_0}{Q_0}$$

The input admittance may also be expressed in an exact or approximate (for high Q_0) form

$$Y = \frac{1}{R} \sqrt{1 + \tan^2 \theta_Y} \angle \theta_Y \doteq \frac{1}{R} \sqrt{1 + \left(\frac{\omega - \omega_0}{\frac{1}{2} \mathfrak{B}}\right)^2} \angle \tan^{-1} [(\omega - \omega_0) / \frac{1}{2} \mathfrak{B}]$$

² At frequencies remote from resonance, we are often satisfied with very rough results; greater accuracy is not always necessary.

The approximations are valid for frequencies which do not differ from the resonant frequency by more than one-tenth of the resonant frequency.

Drill Problems

15-9 Determine the resonant frequency of a parallel resonant circuit in which: **(a)** $R = 100$ ohms, $C = 0.01$ farad, $L = 1$ henry; **(b)** $\alpha = 0.5$, $\omega_d = 0.866$, $C = 1$ farad; **(c)** $\alpha = 0.01$, $R = 100$ ohms, $L = 0.5$ henry.

Ans. 1 radian/sec; 2 radians/sec; 10 radians/sec

15-10 Determine Q_0 for each network described in Drill Prob. 15-9.

Ans. 1; 10; 100

15-11 Determine Q_0 for a parallel RLC circuit: **(a)** having admittance zeros at $-0.03 \pm j 1.5$; **(b)** whose natural response is a voltage waveform in which each positive maximum is 2 per cent less than the previous positive maximum; **(c)** driven by a 10-ma sinusoidal current source and providing a sinusoidal inductor current at resonance of 0.5 amp.

Ans. 25; 50; 155

15-12 For the circuit of Drill Prob. 15-9a, determine: **(a)** \mathfrak{B} ; **(b)** ω_1 ; **(c)** ω_2 .

Ans. 9.5 radians/sec; 10.5 radians/sec; 1 radian/sec

15-13 For the circuit of Drill Prob. 15-9b, determine: **(a)** \mathfrak{B} ; **(b)** ω_1 ; **(c)** ω_2 .

Ans. 0.618 radian/sec; 1 radian/sec; 1.618 radians/sec

15-14 For a parallel RLC circuit in which $R = 10,000$ ohms, $Q_0 = 100$, and $\omega_0 = 10^7$ radians/sec, determine the amplitude of the sinusoidal voltage produced across the network by a 5-ma sinusoidal current source at a frequency: **(a)** $\omega = 10^7$ radians/sec; **(b)** $\omega = 0.995 \times 10^7$ radians/sec; **(c)** $\omega = 0.9 \times 10^7$ radians/sec.

Ans. 50 volts; 35.4 volts; 2.5 volts

15-5 SERIES RESONANCE

Although we probably find less use for the series RLC circuit than we do for the parallel RLC circuit, it is still worthy of our attention. We shall consider the circuit shown in Fig. 15-17. It should be noted that the various circuit elements are given s (for series) subscripts for the time being in order to avoid confusing them with the parallel elements when the circuits are to be compared.

Our discussion of parallel resonance required a section of considerable length. We could now give the series RLC circuit the same kind of treatment, but it is

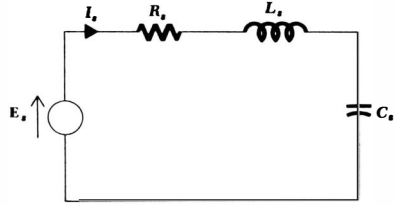

Fig. 15-17 A series resonant circuit.

much cleverer to avoid such needless repetition and use the duality principle. For simplicity, let us concentrate on the conclusions presented in the last paragraph of the preceding section on parallel resonance. The important results are contained there, and the use of dual language enables us to transcribe this paragraph to present the important results for the series *RLC* circuit.

Let us conclude our coverage of the series resonant circuit by summarizing the more important conclusions. The resonant frequency ω_{0s} is the frequency at which the imaginary part of the input impedance becomes zero or the impedance phase angle θ_z becomes zero. Then, $\omega_{0s} = 1/\sqrt{L_s C_s}$. The circuit's figure of merit Q_{0s} is defined as 2π times the ratio of the maximum energy stored in the circuit to the energy lost each period in the circuit. From this definition, we find that $Q_{0s} = \omega_{0s} L_s / R_s$. The two half-power frequencies ω_{1s} and ω_{2s} are defined as the frequencies at which the impedance magnitude is $\sqrt{2}$ times the minimum impedance magnitude. These are also the frequencies at which the current response is 70.7 per cent of the maximum response. The exact and approximate (for high Q_{0s}) expressions for these two frequencies are

$$\omega_{1s, 2s} = \omega_{0s} \left[\sqrt{1 + \left(\frac{1}{2Q_{0s}}\right)^2} \mp \frac{1}{2Q_{0s}} \right] \doteq \omega_{0s} \mp \frac{1}{2} \mathfrak{B}_s$$

where \mathfrak{B}_s is the difference between the upper and the lower half-power frequencies. This half-power bandwidth is given by

$$\mathfrak{B}_s = \omega_{2s} - \omega_{1s} = \frac{\omega_{0s}}{Q_{0s}}$$

The input impedance may also be expressed in an exact or approximate (for high Q_{0s}) form

$$\mathbf{Z}_s = R_s \sqrt{1 + \tan^2 \theta_z} / \theta_z \doteq R_s \sqrt{1 + \left(\frac{\omega - \omega_{0s}}{1/2 \mathfrak{B}_s}\right)^2} \angle \tan^{-1} [(\omega - \omega_{0s}) / 1/2 \mathfrak{B}_s]$$

The approximations are valid for frequencies which do not differ from the resonant frequency by more than one-tenth of the resonant frequency.

The series resonant circuit is characterized by a low impedance at resonance, while the parallel resonant circuit produces a high resonant impedance. The latter circuit provides inductor currents and capacitor currents at resonance which have amplitudes Q_0 times as great as the source current; the series resonant circuit provides inductor voltages and capacitor voltages which are greater than the source voltage by the factor Q_{0s} .

Drill Problems

15-15 Three series resonant circuits are defined below; no special subscripts are used. Find the lower half-power frequency for each circuit. (a) $C = 100 \mu\text{f}$, $R = 100 \text{ ohms}$, $\beta = 1 \text{ radian/sec}$; (b) $\omega_0 = 10 \text{ radians/sec}$, $Q_0 = 100$, $C = 10 \mu\text{f}$; (c) $R = 100 \text{ ohms}$, $L = 5 \text{ henrys}$, $C = 0.002 \text{ farad}$.

Ans. 4.14 radians/sec; 9.5 radians/sec; 9.95 radians/sec

15-16 Find the input impedance of each of the three circuits described in Drill Prob. 15-15 at 9 radians/sec. Use approximations where applicable.

Ans. $101/\underline{-6^\circ}$ ohms; $224/\underline{-63.4^\circ}$ ohms; $2000/\underline{-87.1^\circ}$ ohms

15-17 A series circuit consists of a variable-frequency $1/\underline{0^\circ}$ volt source, a 2-ohm resistor, a 4-henry inductor, and a $1/8$ -farad capacitor. Determine the maximum magnitude of each voltage listed below and the frequency at which the maximum occurs. (a) E_R ; (b) E_C ; (c) E_L .

Ans. 3.04 volts, 1.457 radians/sec; 3.04 volts, 1.544 radians/sec; 1 volt, 1.5 radians/sec

15-6 OTHER RESONANT FORMS

The parallel and series RLC circuits of the previous two sections represent *idealized* resonant circuits; they are no more than useful approximate representations of a physical circuit which might be constructed by combining a coil of wire, a carbon resistor, and a tantalum capacitor in parallel or series. The degree of accuracy with which the idealized model fits the actual circuit depends on the operating frequency range, the Q of the circuit, the materials present in the physical elements, the element sizes, and many other factors. We are not studying the techniques of determining the best model for a given physical circuit, for this requires some knowledge of electromagnetic field theory and the properties of materials; we are, however, concerned with the problem of reducing a more complicated model to one of the two simpler models with which we are more familiar.

The network shown in Fig. 15-18a is a reasonably accurate model for the parallel combination of a physical inductor, capacitor, and resistor. The resistor R_1 represents the ohmic losses, core losses, and radiation losses of the physical coil. The losses in the dielectric within the physical capacitor are accounted for by the resistor R_2 , whose resistance is sometimes large enough that it may be considered infinite. In this model, there is no way to combine elements and produce a simpler model which is equivalent to the original model *for all frequencies*. We shall show, however, that a simpler equivalent may be constructed which is valid over a frequency band which is usually large enough to

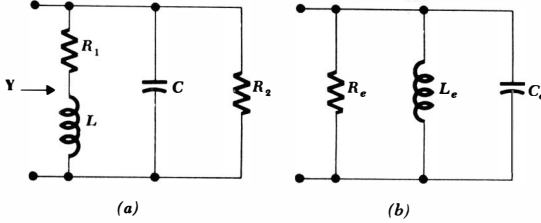

Fig. 15-18 (a) A useful model of a physical network which consists of a physical inductor, capacitor, and resistor in parallel. (b) A network which can be equivalent to (a) over a narrow frequency band.

include all frequencies of interest. The equivalent will take the form of the network shown in Fig. 15-18b.

Before we learn how to develop such an equivalent circuit, let us first consider the given circuit, Fig. 15-18a. The resonant frequency for this network is *not* $1/\sqrt{LC}$, although if R_1 is sufficiently small it may be very close to this value. The definition of resonance is unchanged, and we may determine the resonant frequency by setting the imaginary part of the input admittance equal to zero:

$$\text{Im} [\mathbf{Y}(j\omega)] = \text{Im} \left(\frac{1}{R_2} + j\omega C + \frac{1}{R_1 + j\omega L} \right) = 0$$

Thus,

$$C = \frac{L}{R_1^2 + \omega^2 L^2}$$

and
$$\omega_0 = \sqrt{\frac{1}{LC} - \left(\frac{R_1}{L}\right)^2}$$

We note that ω_0 is less than $1/\sqrt{LC}$, but sufficiently small values of the ratio R_1/L may result in a negligible difference between ω_0 and $1/\sqrt{LC}$.

The maximum magnitude of the input impedance also deserves consideration. It is *not* R_2 , and it does *not* occur at ω_0 (or at $\omega = 1/\sqrt{LC}$). The proof of these statements will not be shown because the expressions soon become algebraically cumbersome; the theory, however, is straightforward. Let us be content with a numerical example. We select $R_1 = 2$ ohms, $L = 1$ henry, $C = 1/8$ farad, and $R_2 = 3$ ohms, and find the resonant frequency

$$\omega_0 = 2 \text{ radians/sec}$$

and the input impedance at resonance

$$\mathbf{Z}(j2) = 1.714 \text{ ohms}$$

At the frequency which would be the resonant frequency *if* R_1 were zero,

$$\frac{1}{\sqrt{LC}} = 2.83 \text{ radians/sec}$$

the input impedance is

$$\mathbf{Z}(j2.83) = 1.947 \angle -13.26^\circ \text{ ohms}$$

However, the frequency at which the maximum impedance magnitude occurs, indicated by ω_m , is found to be

$$\omega_m = 3.26 \text{ radians/sec}$$

and the impedance having the maximum magnitude is

$$\mathbf{Z}(j3.26) = 1.98 \angle -21.4^\circ \text{ ohms}$$

The impedance magnitude at resonance and the maximum magnitude differ by about 13 per cent. Although it is true that such an error may be neglected occasionally in practice, it is too large to neglect on a test. The later work in this section will show that the Q of the inductor-resistor combination at 2 radians/sec is unity; this low value accounts for the 13 per cent discrepancy.

In order to transform the given circuit of Fig. 15-18a into an equivalent of the form of that shown in Fig. 15-18b, we must discuss the Q of a simple series or parallel combination of a resistor and a reactor (inductor or capacitor). We first consider the series circuit shown in Fig. 15-19a. The Q of this network is again defined as 2π times the ratio of the maximum stored energy to the energy lost each period, but the Q may be evaluated at any frequency we choose. In other words, Q is a function of ω . It is true that we shall choose to evaluate it at a frequency which is, or apparently is, the resonant frequency of some network of which the series arm is a part. This frequency, however, is not known until a more complete circuit is available. In Prob. 60 at the end of the chapter we are offered the opportunity to show that the Q of this series arm is $|X_s|/R_s$, whereas the Q of the parallel network of Fig. 15-19b is $R_p/|X_p|$.

Let us now carry out the details necessary to find values for R_p and X_p so that the parallel network of Fig. 15-19b is equivalent to the series network of Fig. 15-19a at some single specific frequency. We equate \mathbf{Y}_s and \mathbf{Y}_p ,

$$\mathbf{Y}_s = \frac{1}{R_s + jX_s} = \frac{R_s - jX_s}{R_s^2 + X_s^2} = \mathbf{Y}_p = \frac{1}{R_p} - j\frac{1}{X_p}$$

Fig. 15-19 (a) A given network which consists of a resistor R_s and an inductor or capacitor with reactance X_s may be transformed into a parallel network (b) such that $\mathbf{Y}_s = \mathbf{Y}_p$ at one specific frequency. The reverse transformation is also possible.

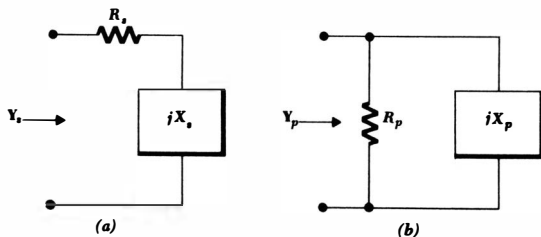

461 Frequency Response

and obtain

$$R_p = \frac{R_s^2 + X_s^2}{R_s} \quad X_p = \frac{R_s^2 + X_s^2}{X_s}$$

Dividing these two expressions, we find

$$\frac{R_p}{X_p} = \frac{X_s}{R_s}$$

It follows that the Q 's of the series and parallel networks must be equal:

$$Q_p = Q_s = Q$$

The transformation equations may therefore be simplified:

$$R_p = R_s(1 + Q^2) \quad (15-22)$$

$$X_p = X_s \left(1 + \frac{1}{Q^2}\right) \quad (15-23)$$

It is apparent that R_s and X_s may also be found if R_p and X_p are the given values; the transformation in either direction may be performed.

If $Q \geq 5$, little error is introduced by using the approximate relationships

$$R_p \doteq Q^2 R_s \quad (15-24)$$

$$X_p \doteq X_s \quad (C_p \doteq C_s \text{ or } L_p \doteq L_s) \quad (15-25)$$

As an example, consider the series combination of a 100-mh inductor and a 5-ohm resistor. We shall perform the transformation at a frequency of 1000 radians/sec, a value selected because it is approximately the resonant frequency of the network (not shown) of which this series arm is a part. We find that X_s is 100 ohms and Q is 20. Since the Q is sufficiently high, we use Eqs. (15-24) and (15-25) to obtain

$$R_p \doteq Q^2 R_s = 2000 \text{ ohms} \quad L_p \doteq L_s = 100 \text{ mh}$$

The conclusion is that a 100-mh inductor in series with a 5-ohm resistor provides essentially the same input impedance as does a 100-mh inductor in parallel with a 2000-ohm resistor *at the frequency* 1000 radians/sec. In order to check the accuracy of the equivalence, let us evaluate the input impedance for each network at 1000 radians/sec. We find

$$\mathbf{Z}_s(j1000) = 5 + j100 = 100.1/\underline{87.1^\circ}$$

$$\mathbf{Z}_p(j1000) = \frac{2000(j100)}{2000 + j100} = 99.9/\underline{87.1^\circ}$$

and conclude that the approximation is exceedingly accurate at the transformation frequency. The accuracy at 900 radians/sec is also reasonably accurate, because

$$\mathbf{Z}_s(j900) = 90.1/\underline{86.8^\circ}$$

$$\mathbf{Z}_p(j900) = 89.9/\underline{87.4^\circ}$$

If this inductor and series resistor had been used as part of a series RLC circuit for which the resonant frequency was 1000 radians/sec, then the half-power bandwidth would have been

$$\mathfrak{B} = \frac{\omega_0}{Q_0} = \frac{1000}{20} = 50$$

and the frequency of 900 radians/sec would have represented a frequency that was 4 half bandwidths off resonance. Thus the equivalent networks that we have evaluated above would have been adequate for reproducing essentially all the peaked portion of the response curve.

As a further example of the replacement of a more complicated resonant circuit by an equivalent series or parallel RLC circuit, let us consider a problem in electronic instrumentation. The simple series RLC network in Fig. 15-20a is excited by a sinusoidal voltage source at the resonant frequency. The effective value of the source voltage is 0.5 volt, and we wish to measure the effective value of the voltage across the capacitor with a vacuum-tube voltmeter (VTVM) having an internal resistance of 100,000 ohms. That is, an equivalent representation of the vacuum-tube voltmeter is an ideal voltmeter in parallel with a 100,000-ohm resistor.

Before the vacuum-tube voltmeter is connected, we find that the resonant frequency is 10^5 radians/sec, $Q_0 = 50$, the current is 25 ma, and the rms capacitor voltage is 25 volts. As indicated at the end of Sec. 15-5, this voltage is Q_0 times the applied voltage. Thus, if the vacuum-tube voltmeter were ideal, it would read 25 volts when connected across the capacitor.

However, when the actual vacuum-tube voltmeter is connected, the circuit shown in Fig. 15-20b results. In order to obtain a series RLC circuit, it is now necessary to replace the parallel RC network by a series RC network. Let us assume that the Q of this RC network is sufficiently high so that the equivalent series capacitor will be the same as the given parallel capacitor. We do this in order to approximate the resonant frequency of the final series RLC circuit. Thus, if the series RLC circuit also contains a 0.01- μ f capacitor, the resonant frequency remains 10^5 radians/sec. We need to know this estimated resonant frequency in order to calculate the Q of the parallel RC network; it is

$$Q = \frac{R_p}{|X_p|} = \omega R_p C_p = 10^5(10^5)(10^{-8}) = 100$$

Since this value is greater than 5, our vicious circle of assumptions is justified, and the equivalent series RC network consists of the capacitor

$$C_s = 0.01 \mu\text{f}$$

and the resistor

$$R_s = \frac{R_p}{Q^2} = 10 \text{ ohms}$$

Hence, the equivalent circuit of Fig. 15-20c is obtained. The resonant Q of this circuit is now only 33.3, and thus the voltage across the capacitor in the circuit of Fig. 15-20c is 16⅔ volts. But we need to find $|\mathbf{E}'_c|$, the voltage across the series

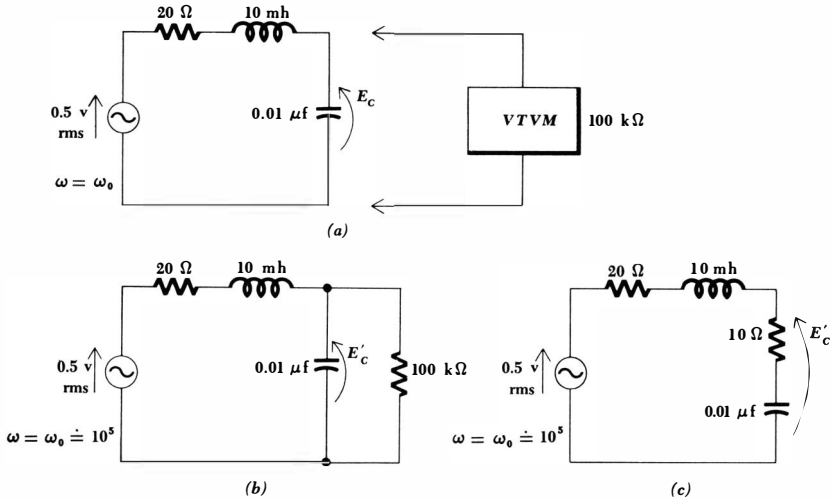

Fig. 15-20 (a) A given series resonant circuit in which the capacitor voltage is to be measured by a nonideal vacuum-tube voltmeter. (b) The effect of the vacuum-tube voltmeter is included in the circuit; the vacuum-tube voltmeter reads E'_c volts. (c) A series resonant circuit is obtained when the parallel RC network in (b) is replaced by the series RC network which is equivalent at 10^5 radians/sec.

RC combination; we obtain

$$|E'_c| = \frac{0.5}{30} |10 - j1000| = 16.7 \text{ volts}$$

The capacitor voltage and $|E'_c|$ are essentially equal since the voltage across the 10-ohm resistor is quite small.

The final conclusion must be that an apparently good voltmeter may produce a severe effect on the response of a high- Q resonant circuit. A similar effect may occur when a nonideal ammeter is inserted in the circuit.

Drill Problems

15-18 Find a two-element parallel equivalent network at $\omega = 10$ for the series network consisting of: (a) $R_s = 10$ ohms, $L_s = 10$ henrys; (b) $R_s = 10$ ohms, $C_s = 100 \mu\text{f}$; (c) $R_s = 100$ ohms, $L_s = 5$ henrys.

Ans. 1000 ohms, 10 henrys; 125 ohms, 25 henrys; 100 kilohms, 100 μf

15-19 Find a two-element series equivalent network at $\omega = 2$ for the parallel network consisting of: (a) $R_p = 5$ ohms, $L_p = 0.1$ henry; (b) $R_p = 5$ ohms, $L_p = 2$ henrys; (c) $R_p = 5$ ohms, $L_p = 25$ henrys.

Ans. 1.95 ohms, 1.22 henrys; 4.95 ohms, 0.248 henry; 0.008 ohm, 0.1 henry

15-20 Find the Q_0 for the circuit shown in Fig. 15-18a if: (a) $L = 1$ henry, $C = 1$ farad, $R_1 = 0$, $R_2 = 10$ ohms; (b) $L = 1$ henry, $C = 1$ farad, $R_1 = 0.1$ ohm, $R_2 = \infty$; (c) $L = 1$ henry, $C = 1$ farad, $R_1 = 0.1$ ohm, $R_2 = 10$ ohms.

Ans. 5; 10; 10

15-7 SCALING

The greater number of the examples and problems which we have been solving have involved circuits containing element values ranging around a few ohms, a few henrys, and a few farads. The applied frequencies usually were a few radians per second. These particular numerical values were used not because they are those commonly met in practice, but because mathematical manipulations are so much easier than they would be if it were necessary to carry along various powers of 10 throughout the calculations. The scaling procedures that will be discussed in this section enable us to analyze networks composed of practical-sized elements by scaling the element values to permit more convenient numerical calculations. We shall consider both magnitude scaling and frequency scaling.

Let us select the parallel resonant circuit shown in Fig. 15-21a as our example. The impractical element values lead to the unlikely response curve drawn as Fig. 15-21b; the maximum impedance is 5 ohms, the resonant frequency is 1 radian/sec, Q_0 is 10, and the bandwidth is 0.1 radian/sec. These numerical values are much more characteristic of the electrical analog of some mechanical system than they are of any basically electrical device. We have convenient numbers with which to calculate but an impractical circuit to construct.

Let us assume that our goal is to scale this network in such a way as to provide an impedance maximum of 10,000 ohms at a resonant frequency of 5×10^6 radians/sec, or 796 kc. In other words, we may use the same response curve

Fig. 15-21 (a) A parallel resonant circuit used as an example to illustrate magnitude and frequency scaling. (b) The magnitude of the impedance is shown as a function of frequency.

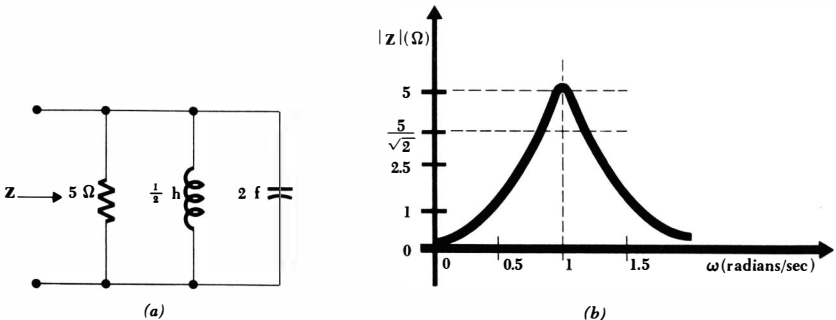

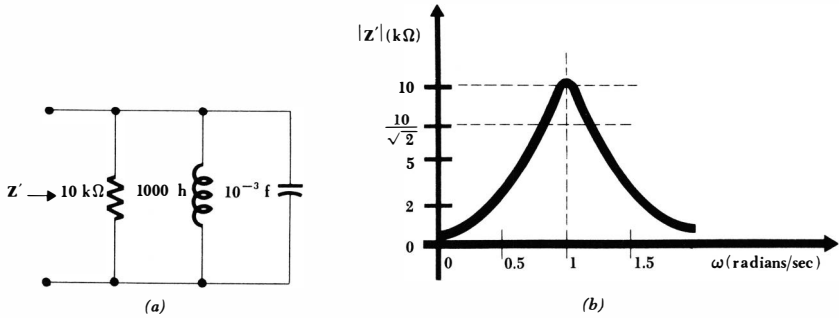

Fig. 15-22 (a) The network of Fig. 15-21a after being scaled in magnitude by a factor $K_m = 2000$. (b) The corresponding response curve.

shown in Fig. 15-21b if every number on the ordinate scale is increased by a factor of 2000 and every number on the abscissa scale is increased by a factor of 5×10^6 . We shall treat this as two problems: (1) scaling in magnitude by a factor of 2000 and (2) scaling in frequency by a factor of 5×10^6 .

Magnitude scaling is defined as the process by which the *impedance* of a two-terminal network is increased by a factor of K_m , the frequency remaining constant. The factor K_m is real and positive; it may be greater or smaller than unity. We shall understand that the shorter statement, “the network is scaled in magnitude by a factor of 2,” infers that the impedance of the new network is to be *twice* that of the old network at any frequency. Let us now determine how we must scale each type of passive element. To increase the input impedance of a network by a factor of K_m , it is sufficient to increase the impedance of each element in the network by this same factor. Thus, a resistor R must be replaced by a resistor $K_m R$. Each inductor must also exhibit an impedance which is K_m times as great at any frequency. In order to increase an impedance sL by a factor of K_m when s remains constant, the inductor L must be replaced by an inductor $K_m L$. In a similar manner, each capacitor C must be replaced by a capacitor C/K_m . In summary, these changes will produce a network which is scaled in magnitude by a factor of K_m :

$$\left. \begin{aligned} R &\rightarrow K_m R \\ L &\rightarrow K_m L \\ C &\rightarrow \frac{C}{K_m} \end{aligned} \right\} \text{magnitude scaling}$$

When each element in the network of Fig. 15-21a is scaled in magnitude by a factor of 2000, the network shown in Fig. 15-22a results. The response curve shown in Fig. 15-22b indicates that no change in the previously drawn response curve need be made other than a change in the scale of the ordinate.

Let us now take this new network and scale it in frequency. We define *frequency scaling* as the process by which the frequency at which any impedance

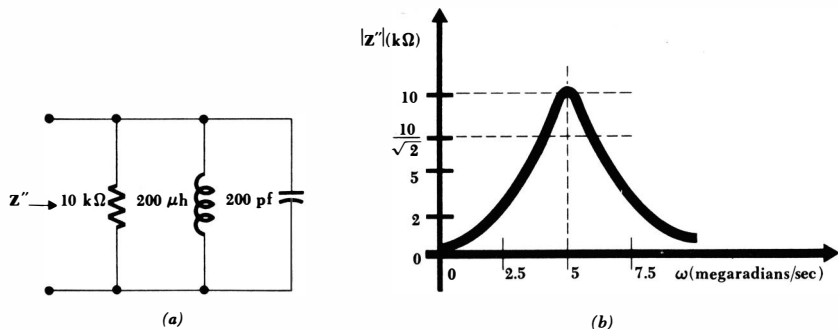

Fig. 15-23 (a) The network of Fig. 15-22a after being scaled in frequency by a factor $K_f = 5 \times 10^6$. (b) The corresponding response curve.

occurs is increased by a factor of K_f . Again, we shall make use of the shorter expression, “the network is scaled in frequency by a factor of 2,” to infer that the same impedance is now obtained at a frequency twice as great. Again, frequency scaling is accomplished by scaling each passive element in frequency. It is apparent that no resistor is affected. The impedance of any inductor is sL , and if this same impedance is to be obtained at a frequency K_f times as great, then the inductor L must be replaced by one having an inductance of L/K_f . Similarly, a capacitor C is to be replaced by one having a capacitance C/K_f . Thus, if a network is to be scaled in frequency by a factor of K_f , then the changes necessary in each passive element are

$$\left. \begin{array}{l} R \rightarrow R \\ L \rightarrow \frac{L}{K_f} \\ C \rightarrow \frac{C}{K_f} \end{array} \right\} \text{frequency scaling}$$

When each element of the magnitude-scaled network of Fig. 15-22a is scaled in frequency by a factor of 5×10^6 , the network of Fig. 15-23a is obtained. The corresponding response curve is shown in Fig. 15-23b.

The circuit elements in this last network have values which are easily achieved in physical circuits; the network can actually be built and tested. It follows that, if the original network of Fig. 15-21a were actually an analog of some mechanical resonant system, we could have scaled this analog in both magnitude and frequency in order to achieve a network which we might construct in the laboratory; tests that are expensive or inconvenient to run on the mechanical system could then be made on the scaled electrical system, and the results should then be “unscaled” and converted into mechanical units to complete the analysis.

The effect of magnitude scaling or frequency scaling on the pole-zero constel-

lation of an impedance is not very difficult to ascertain, but its determination offers such an excellent opportunity to review the meaning and significance of a pole-zero plot in the s plane that it is called for in one of the drill problems below.

An impedance which is given as a function of s may also be scaled in magnitude or frequency, and this may be done without any knowledge of the specific elements out of which the two-terminal network is composed. In order to scale $\mathbf{Z}(s)$ in magnitude, the definition of magnitude scaling shows that it is only necessary to multiply $\mathbf{Z}(s)$ by K_m in order to obtain the magnitude-scaled impedance. Thus, the impedance of the parallel resonant circuit shown in Fig. 15-21a is

$$\mathbf{Z}(s) = \frac{s}{2s^2 + 0.2s + 2}$$

or
$$\mathbf{Z}(s) = 0.5 \frac{s}{(s + 0.05 + j0.999)(s + 0.05 - j0.999)}$$

The impedance $\mathbf{Z}'(s)$ of the magnitude-scaled network is

$$\mathbf{Z}'(s) = K_m \mathbf{Z}(s)$$

and, therefore,

$$\mathbf{Z}'(s) = 1000 \frac{s}{(s + 0.05 + j0.999)(s + 0.05 - j0.999)}$$

If $\mathbf{Z}'(s)$ is now to be scaled in frequency by a factor of 5×10^6 , then $\mathbf{Z}''(s)$ and $\mathbf{Z}'(s)$ are to provide identical values of impedance if $\mathbf{Z}''(s)$ is evaluated at a frequency K_f times that at which $\mathbf{Z}'(s)$ is evaluated. After some careful cerebral activity, this conclusion may be stated concisely in functional notation:

$$\mathbf{Z}''\left(\frac{s}{K_f}\right) = \mathbf{Z}'(s)$$

Remember that the correspondence results when a larger value of s is used in \mathbf{Z}'' (assuming that $K_f > 1$). In other words, we obtain $\mathbf{Z}''(s)$ by replacing every s in $\mathbf{Z}'(s)$ by s/K_f . The analytic expression for the impedance of the network shown in Fig. 15-23a must therefore be

$$\mathbf{Z}''(s) = 1000 \frac{s/(5 \times 10^6)}{[s/(5 \times 10^6) + 0.05 + j0.999][s/(5 \times 10^6) + 0.05 - j0.999]}$$

or

$$\mathbf{Z}''(s) =$$

$$5 \times 10^9 \frac{s}{(s + 0.25 \times 10^6 + j4.994 \times 10^6)(s + 0.25 \times 10^6 + j4.994 \times 10^6)}$$

Drill Problems

15-21 Find the input impedance at resonance and the bandwidth of a series resonant circuit consisting of a 10-ohm resistor, a 10-henry in-

ductor, and a 0.1-farad capacitor after this given network is: (a) scaled in frequency by a factor of 10; (b) scaled in magnitude by a factor of 10; (c) scaled in magnitude and frequency by factors of 10.

Ans. 100 ohms, 1 radian/sec; 10 ohms, 10 radians/sec; 100 ohms, 10 radians/sec

15-22 A given parallel resonant circuit has an impedance of 60 ohms at resonance, a Q_0 of 12, and a bandwidth of 8 radians/sec. Determine the new Q_0 and new capacitance if the circuit is: (a) scaled in magnitude by a factor of 2; (b) scaled in frequency by a factor of 2; (c) scaled in magnitude and frequency by factors of 2.

Ans. 12, 520 μf ; 12, 1040 μf ; 12, 1040 μf

15-23 One of the zeros of an impedance is located at $s_1 = -2 + j6$. Determine the location of this zero if the impedance is: (a) scaled in magnitude by a factor of 2; (b) scaled in frequency by a factor of 2; (c) scaled in magnitude and frequency by factors of 2.

Ans. $-4 + j12$ radians/sec; $-4 + j12$ radians/sec; $-2 + j6$ radians/sec

15-24 Given an admittance $Y(s) = (2s^2 + 8s + 4)/(3s + 2)$, write the analytical form for this admittance after the impedance has been: (a) scaled in frequency by a factor of 2; (b) scaled in magnitude by a factor of 2; (c) scaled in magnitude and frequency by factors of 2.

Ans. $\frac{s^2 + 4s + 2}{3s + 2}$ mhos; $\frac{0.5s^2 + 4s + 4}{1.5s + 2}$ mhos; $\frac{0.25s^2 + 2s + 2}{1.5s + 2}$ mhos

Problems

- 1 Prepare a useful table in which both the impedance locus and admittance locus are shown for each of the six networks described below. On each locus indicate $\omega = 0$, $\omega = \infty$, the direction of traversal as ω increases, and for the first four networks the point and value of ω at which the immittance phase angle is $\pm 45^\circ$. For the last two networks, locate ω_1 , ω_2 , and ω_0 . (a) The series combination of R_1 and L_1 . (b) The series combination of R_1 and C_1 . (c) The parallel combination of R_1 and L_1 . (d) The parallel combination of R_1 and C_1 . (e) The series combination of R_1 , L_1 , and C_1 . (f) The parallel combination of R_1 , L_1 , and C_1 .
- 2 (a) Draw the impedance locus for an impedance which has a single zero on the negative σ axis (and, of course, a pole at $s = \infty$). (b) Repeat for a pole on the negative σ axis.
- 3 Prove that any circle in the Z plane with its center on the real axis maps into a circle in the Y plane with center on the real axis, and vice versa.

One method of proving this statement involves writing the equation of a general circle in the Z plane which is centered on the r axis, expressing r and x as functions of g and b , substituting these expressions into the equation of the circle, and simplifying the resultant expression until the desired equation of a circle in the Y plane is apparent.

- 4 Prove that a vertical straight line in the Z plane will map into a circle in the Y plane, centered on the real axis and passing through the origin. One method of proof proceeds as follows: Let $r = a$; show that $r = g/(g^2 + b^2)$ and then that $(g - 1/2a)^2 + b^2 = (1/2a)^2$.
- 5 Draw the impedance locus for each network shown in Fig. 15-24.
- 6 Draw the admittance locus for each network shown in Fig. 15-25.
- 7 Draw the impedance locus for the network shown in Fig. 15-26a.
- 8 Find the admittance locus for the network shown in Fig. 15-26b, and use the locus to determine the resonant frequency ($\text{ang } Y = 0^\circ, 0 < \omega_0 < \infty$).
- 9 (a) For the circuit shown in Fig. 15-26c, draw the locus of the impedance seen by the source. Identify the more interesting frequencies. (b) Draw the exact dual of this circuit. (c) For this dual circuit, draw the locus of the impedance seen by the source.
- 10 (a) A 2-ohm resistor is in parallel with the series combination of a 4-ohm resistor and a 10-farad capacitor. Draw the locus of the admittance offered to a current source connected across the 2-ohm resistor. (b) Construct the exact dual of this circuit and then draw the locus of the impedance offered to the dual of the current source.
- 11 The pole-zero configuration of an impedance for which $Z(0) = 5$ is shown in Fig. 15-27a. (a) Sketch the impedance locus and admittance locus.

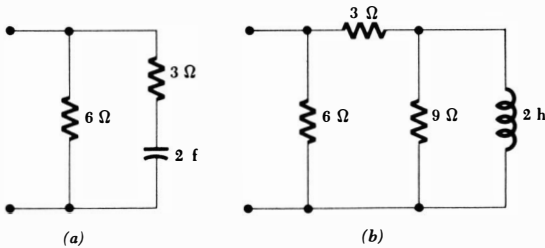

Fig. 15-24 See Prob. 5.

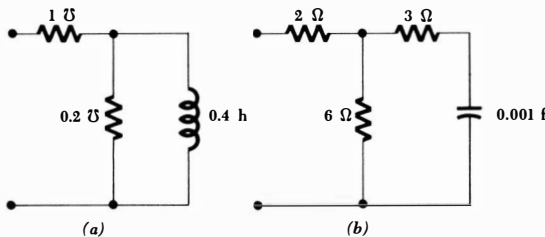

Fig. 15-25 See Prob. 6.

470 **Complex Frequency**

- ♦(b) From the Z locus, determine graphically the maximum value of the impedance phase angle. ♦(c) From the pole-zero constellation, estimate the frequency at which this maximum phase angle occurs.
- 12 The admittance locus of a two-element network is shown in Fig. 15-27b. Determine the exact network and draw its impedance locus.
- 13 Find the Z locus for the network shown in Fig. 15-28a and the Y locus for the network shown in Fig. 15-28b.

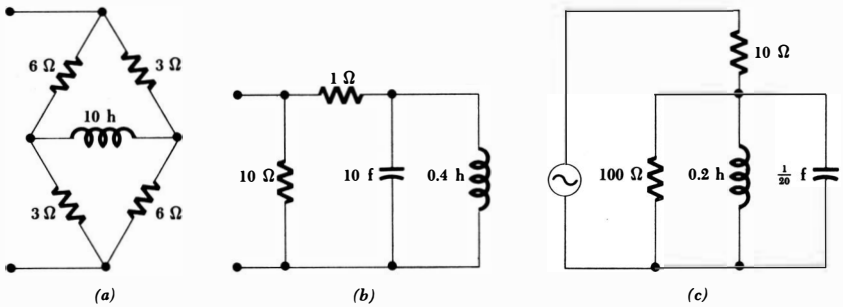

Fig. 15-26 (a) See Prob. 7. (b) See Prob. 8. (c) See Prob. 9.

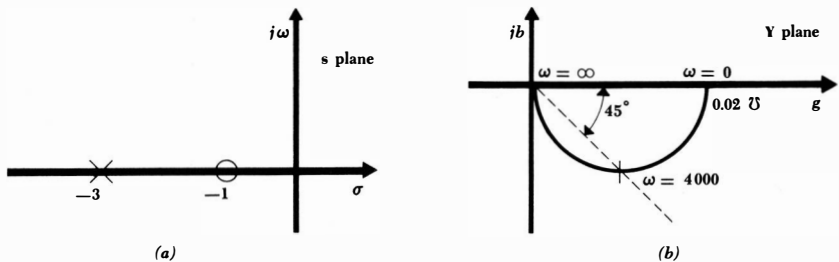

Fig. 15-27 (a) See Prob. 11. (b) See Prob. 12.

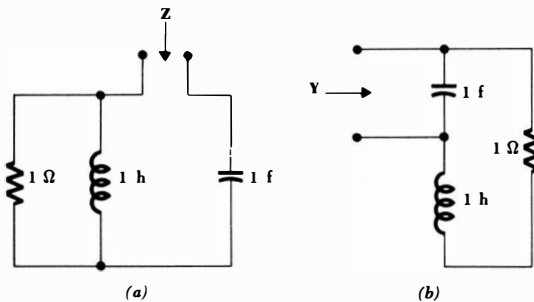

Fig. 15-28 See Prob. 13.

471 *Frequency Response*

- ◆14 The voltage E_s is applied to the series combination of a 2-ohm resistor, a 0.1-farad capacitor, and a 10-henry inductor. Draw the locus of the ratio of the resistor voltage to E_s ; indicate all interesting points.
- 15 Construct the impedance locus for each of the networks shown in Fig. 15-29.
- ◆16 For the network shown in Fig. 15-30a, make an accurate impedance locus; from the locus, determine the resonant frequency and the minimum value of the impedance magnitude.
- 17 Sketch the locus of the impedance of the network shown in Fig. 15-11a as R varies from zero to infinity. Let $\omega = 2$.
- 18 Plot the locus of E_0/E for the network shown in Fig. 15-30b.
- ◆19 Draw the locus of E_0/E for the network shown in Fig. 15-31a.
- 20 Draw the locus of E_0/E for the network shown in Fig. 15-31b.

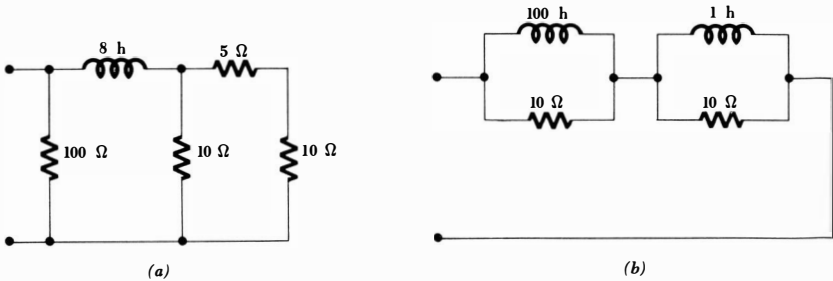

Fig. 15-29 See Prob. 15.

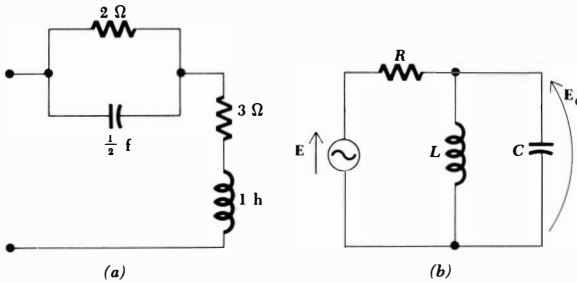

Fig. 15-30 (a) See Prob. 16. (b) See Prob. 18.

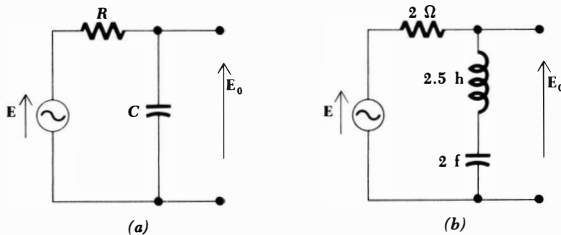

Fig. 15-31 (a) See Prob. 19. (b) See Prob. 20.

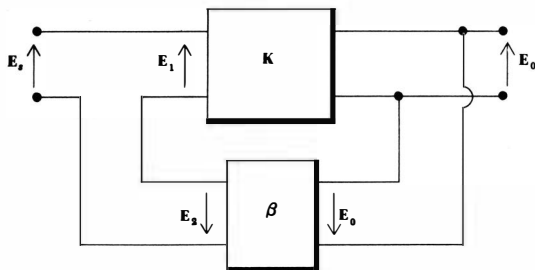

Fig. 15-32 See Prob. 22.

- 21 A black box has two pairs of terminals. The voltage \mathbf{E} is applied at one pair of terminals, and the voltage \mathbf{E}_0 is measured as a response at the second pair of terminals. If $\mathbf{E}_0/\mathbf{E} = (s^2 + 6s + 5)/(s + 1)$, sketch the locus of \mathbf{E}_0/\mathbf{E} .
- 22 A feedback amplifier is shown in block form in Fig. 15-32. The forward gain \mathbf{K} is $\mathbf{E}_0/\mathbf{E}_1$, and the gain of the feedback network is $\beta = \mathbf{E}_2/\mathbf{E}_0$. The gain of the feedback amplifier is known to be $\mathbf{G} = \mathbf{E}_0/\mathbf{E}_s = \mathbf{K}/(1 - \beta\mathbf{K})$. The theory of feedback amplifiers shows that the amplifier will become unstable and oscillate if the locus of $\beta\mathbf{K}$ encircles the point $1 + j0$ on the complex $\beta\mathbf{K}$ plane. Plot the $\beta\mathbf{K}$ loci (called Nyquist diagrams) for the amplifiers described below and determine whether or not they are stable:

$$(a) \mathbf{K} = -\frac{10s}{s+1}, \beta = 1 \quad (b) \mathbf{K} = \left(-\frac{s}{s+1}\right)^3, \beta = 10$$

- 23 An inductor L is in series with an adjustable resistor R . Sketch the loci of the impedance and admittance as R is varied from zero to infinity.
- 24 A variable resistor R and a variable inductor L are in parallel. Draw the locus of the impedance of this parallel combination if: (a) ω is the parameter; (b) R is the parameter; (c) L is the parameter. Also construct the three corresponding admittance loci.
- 25 Repeat Prob. 24 if the variable inductor is replaced with a variable capacitor C .
- 26 A sinusoidal current source drives the parallel combination of an adjustable capacitor C and the series combination of a 10-ohm resistor and a 0.01-henry inductor. (a) Sketch the \mathbf{Y} locus with C as parameter. (b) Determine the value of C which will cause the impedance magnitude to be a maximum.
- 27 A sinusoidal voltage source drives the parallel combination of a 100- μf capacitor and the series combination of a 0.1-mh inductor and an adjustable resistor R . Draw the \mathbf{Y} locus with R as the parameter at a constant frequency of 10,000 radians/sec.
- 28 A 3-ohm resistor, a $\frac{1}{4}$ -henry inductor, and a $\frac{1}{9}$ -farad capacitor are in parallel. Find: (a) ω_0 ; (b) f_0 ; (c) Q_0 ; (d) α ; (e) ω_d ; (f) $s_{2,4}$.

473 **Frequency Response**

- 29 A sinusoidal current $2 \cos \omega_0 t$ amp is applied to the network described in Prob. 28. Find: (a) E ; (b) I_R ; (c) I_L ; (d) I_C ; (e) P_R ; (f) w_L ; (g) w_C ; (h) the ratio of $|I_L|$ to the magnitude of the source current; (i) the ratio of $|I_C|$ to the magnitude of the source current.
- 30 In a parallel resonant circuit find R , L , and C if: (a) $f_0 = 60$ cps, $Q_0 = 20$, $R = 10$ ohms; (b) $C = 0.01 \mu\text{f}$, $\alpha = 1000$, $Q_0 = 100$; (c) $I_s = 5$ amp, $P_{R0} = 2$ watts, $W_0 = 100$ joules, $Q_0 = 5$.
- 31 The Q of a parallel RLC network may be obtained by applying the definition of Q to the natural response. Assume a high- Q network and a natural response of the form $e(t) = E_0 e^{-\alpha t} \cos \omega_d t$. Determine the stored energy at $t = 0$ and $t \doteq 2\pi/\omega_d \doteq 2\pi/\omega_0$, the time at which e has its first maximum after $t = 0$. From these facts, find Q_0 .
- 32 The source-free response of a parallel RLC network, as displayed on an oscilloscope, indicates successive positive maxima of 81 and 80 divisions. The maxima are separated $1.2 \mu\text{sec}$. Find Q_0 .
- 33 A microphone connected through an amplifier to a cathode-ray oscilloscope is placed next to a xylophone. Middle C is struck sharply several times, and each time the cathode-ray-oscilloscope sweep speed is changed and the result photographed. Two such photographs are "shown" in Fig. 15-33a and b with time-scale calibrations by 500- and 5-cps sine waves.
- 34 A resonant circuit loses 1.2 per cent of its stored energy every period after it has been set into a source-free response. Find Q_0 .
- 35 For the circuit shown in Fig. 15-34a: (a) Find Q_0 and I_L . (b) An r-f ammeter having a resistance of 2 ohms is placed in series with the inductor; assume that the currents and voltages throughout the circuit are essentially unaltered and find the power input to the ammeter. (c) By what percentage does this change the total power drawn by the circuit and the Q_0 ?
- 36 Find the bandwidth and upper and lower half-power frequencies for the resonant circuit shown in Fig. 15-34b.
- 37 A microwave cavity is resonant at 9500 mc with a Q_0 of 10,000. These are typical values for good equipment. Without identifying the ordinate

Fig. 15-33 See Prob. 33.

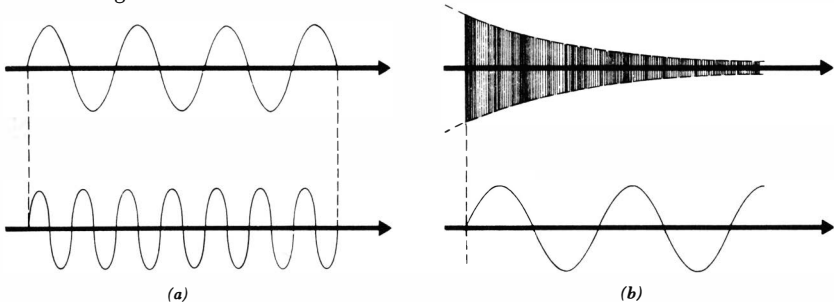

474 **Complex Frequency**

as current, voltage, impedance, or admittance, draw a response curve for this resonant circuit with a maximum value of unity. Locate three points of the curve carefully.

- 38 A current source I_s is in parallel with a parallel RLC network. (a) Show the maximum amplitude of the inductor current is $Q_0 |I_s| / \sqrt{1 - 1/4Q_0^2}$ and that it occurs at $\omega_0 \sqrt{1 - 1/2Q_0^2}$ radians/sec. (b) Show that the maximum capacitor current equals the maximum inductor current, but that it occurs at $\omega_0 / \sqrt{1 - 1/2Q_0^2}$ radians/sec.
- 39 A parallel circuit containing $R = 1$ ohm, $C = 0.2$ farad, $L = 0.05$ henry has a 10-amp sinusoidal signal applied. Find the maximum magnitude of each of the following quantities and the frequency at which that maximum occurs: Z , E , I_R , I_C , and I_L .
- ◆40 In the circuit shown in Fig. 15-35, find $|I_L|$. The easy method of solution is recommended.
- 41 Design a parallel circuit that is resonant at 1 mc, with a 10-kc bandwidth. Assume that the dielectric between the capacitor plates has a total resistance of 10,000 ohms, and use no additional resistors or lossy elements.
- ◆42 A parallel resonant circuit has $Q_0 = 50$ at $\omega_0 = 10^8$ radians/sec; $R = 1000$ ohms. Let θ_Y be the angle of the admittance $Y = |Y| \angle \theta_Y$. (a) Find $\frac{1}{2}\beta_B$ (in radians per second). (b) Compute $(\omega - \omega_0) / \frac{1}{2}\beta_B$ for $\omega / 10^6 = 90, 95, 99, 100, 101, 105, 110$. (c) Compute $\tan \theta_Y$ for the same frequencies. (d) Compare the results of parts b and c. Which set of calculations was easier? (e) Show that $Y = (1/R) \sqrt{1 + \tan^2 \theta_Y / \theta_Y}$ and thus that

$$Y \doteq \frac{1}{R} \sqrt{1 + \left(\frac{\omega - \omega_0}{\frac{1}{2}\beta_B} \right)^2} \angle \tan^{-1} \frac{\omega - \omega_0}{\frac{1}{2}\beta_B}$$

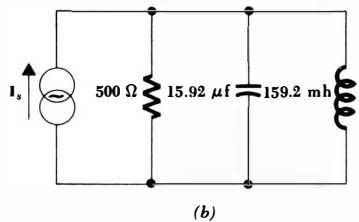
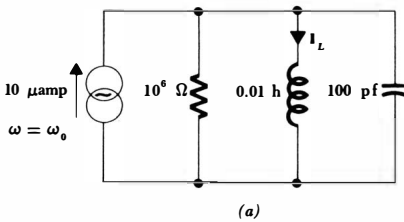

Fig. 15-34 (a) See Prob. 35. (b) See Prob. 36.

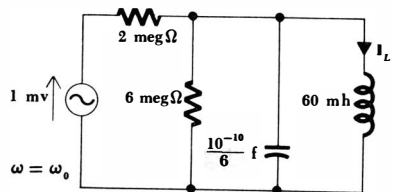

Fig. 15-35 See Prob. 40.

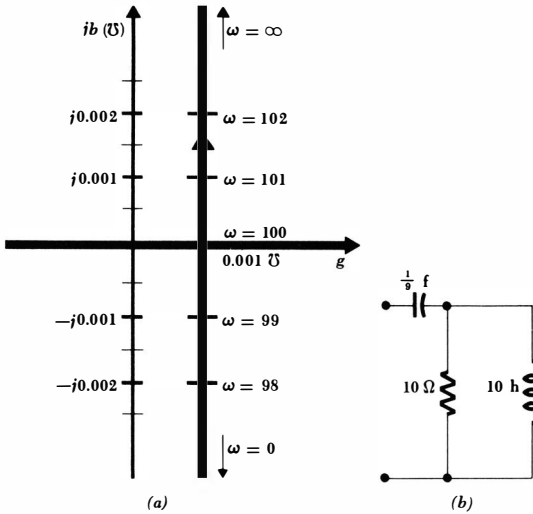

Fig. 15-36 (a) See Prob. 46. (b) See Prob. 47.

- 43 A parallel resonant circuit has $f_0 = 60$ cps, $Q_0 = 15$, $R = 500$ ohms. Use approximate methods to calculate $|Y|$ and $\text{ang } Y$ at 2-cps intervals near resonance. Compute only those points for which the approximation is reasonably valid, and sketch the resultant curves.
- 44 A parallel circuit is composed of R_1 , L_1 , and C_1 . A new circuit with R_2 , L_2 , and C_2 is to be constructed having different, although related, characteristics. Find R_2 , L_2 , and C_2 in terms of R_1 , L_1 , and C_1 if: (a) the resonant frequency is doubled without changing Q_0 or the admittance at resonance; (b) Q_0 is doubled without changing the resonant frequency or the admittance at resonance; (c) the admittance at resonance is doubled without changing Q_0 or the resonant frequency; (d) the resonant frequency is doubled without changing Q_0 or the bandwidth.
- 45 Design a parallel resonant circuit to produce a pure conductance of 25 μmhos at 1 mc and an admittance magnitude of 50 μmhos at frequencies 10 kc above and below 1 mc.
- 46 The locus of the input admittance of a resonant circuit is shown in Fig. 15-36a. (a) What is the resonant frequency of this circuit? (b) Find Q_0 . (c) Sketch a suitable three-element network having the given input admittance. Give all element values.
- 47 For the circuit shown in Fig. 15-36b, evaluate the exact resonant frequency.
- 48 Given R , L , and C in series, find Q_0 if: (a) $R = 2$ ohms, $L = 1$ mh, $C = 1000$ pf; (b) $L = 100 \mu\text{h}$, $C = 100$ pf, $\mathcal{B} = 20$ kc; (c) $\omega_0 = 10$ radians/sec, $C = 10$ farads, $R = 0.1$ ohm.
- 49 For each series combination in Prob. 48, find ω_1 and Z at ω_1 .
- 50 Given $Y(s) = (s + 2)(s + 10,000)/(s^2 + 3s + 10,000)$: (a) plot the poles and zeros of Y on the s plane; (b) using only the pole-zero plot, determine the approximate values of ω at which the phase angle of $Y(j\omega)$ is zero.

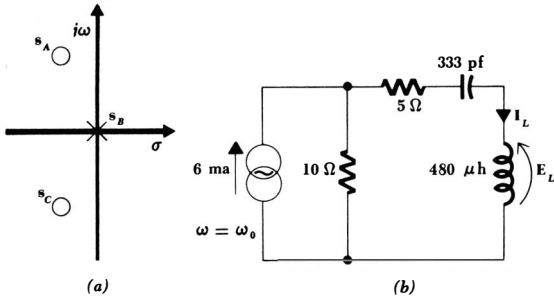

Fig. 15-37 (a) See Prob. 51. (b) See Prob. 52.

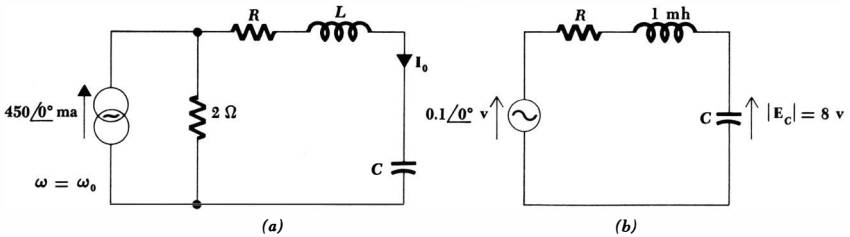

Fig. 15-38 (a) See Prob. 53. (b) See Prob. 54.

- ◆51 For the pole-zero configuration shown in Fig. 15-37a: (a) Does this represent the impedance of a series-resonant or a parallel-resonant circuit? (b) If $s_{A,C} = -100 \pm j 10,000$, find the ratio of Z at a frequency 20 cps above resonance to the impedance at resonance.
- 52 For the circuit shown in Fig. 15-37b, find $|I_L|$ and $|E_L|$.
- ◆53 Determine R , L , and C in the circuit of Fig. 15-38a so that the output current magnitude is 300 ma and the resonant frequency is 10^6 radians/sec. The half-power bandwidth is to be 10^4 radians/sec.
- 54 For the circuit shown in Fig. 15-38b, the source is at the resonant frequency $\omega_0 = 10^5$. (a) Find C . (b) Find R . (c) Find Z at $\omega = 98,500$ radians/sec.
- ◆55 A series-resonant circuit is resonant at 1000 cps with a Q_0 of 2000 (this is physically possible only if positive feedback is applied). If $R = 10$ ohms, find Z at 999.5 cps.
- 56 A certain series RLC circuit contains an inductance of 1 henry. The impedance has a pole at $s = 0$ and zeros at $s = -5 \pm j 100$. (a) Determine the resistance, the resonant frequency, and the half-power frequencies. (b) Draw an accurate sketch of the admittance locus.
- ◆57 Given a series RLC circuit for which $\mathfrak{B} = 5$ radians/sec, $Q_0 = 3$, $L = 1$ henry, find C , R , ω_1 , and ω_2 .
- 58 Find the input impedance at a frequency 8.66 radians/sec above resonance for the series network: $R = 1000$ ohms, $L = 100$ henrys, $C = \frac{1}{2} \mu\text{f}$.

- 59 A series RLC network has $R = 100$ ohms. The impedance has a pole at $s = 0$ and zeros at $s = -1 \pm j10$. Find $Z(j11)$.
- 60 (a) By applying the definition of Q to a series RL and a series RC network, show that $Q_s = |X_s|/R_s$. (b) Show that $Q_p = R_p/|X_p|$ for a parallel RL or RC network.
- 61 For each of the series combinations and operating frequencies shown in Fig. 15-39: (a) find Q_0 ; (b) find the equivalent parallel combination; (c) state whether or not the two representations are reasonably equivalent in the vicinity of the operating frequency.
- 62 For each resonant circuit shown in Fig. 15-40, determine whether or not a simpler equivalent circuit will be valid near resonance and, if so, find the Q_0 of the resultant resonant circuit.

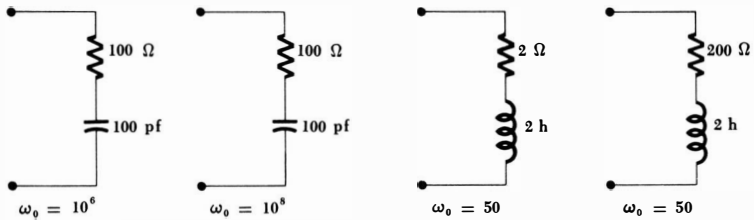
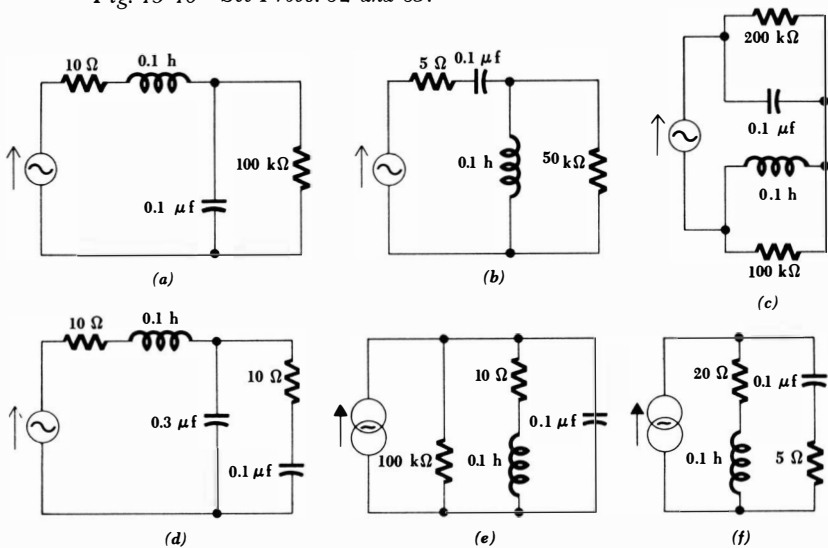

Fig. 15-39 See Prob. 61.

Fig. 15-40 See Probs. 62 and 63.



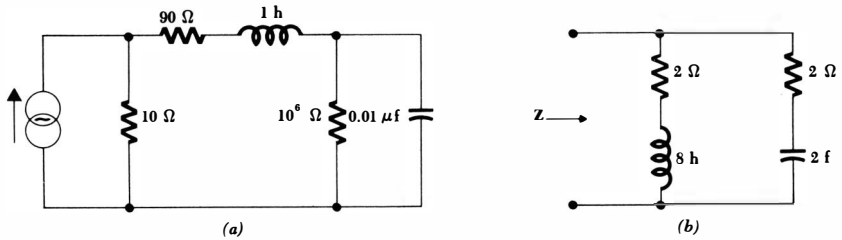

Fig. 15-41 (a) See Prob. 65. (b) See Prob. 66.

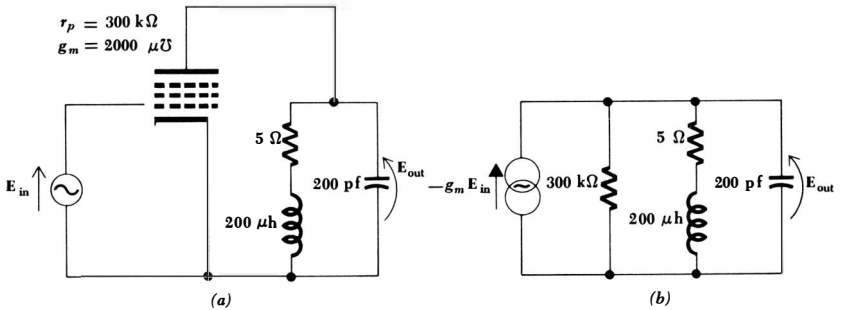

Fig. 15-42 See Prob. 67.

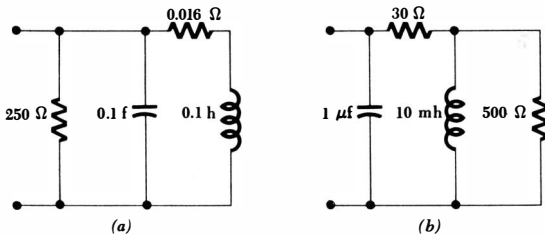

Fig. 15-43 See Probs. 68, 69, 70, and 71.

- 63 For the circuit of Fig. 15-40e, sketch the magnitude of the voltage across the source versus ω , $9500 \leq \omega \leq 10,500$. $I_s = 1$ ma.
- 64 A physical inductor represented by L and R_L in series has a high Q , Q_{0L} . A physical capacitor represented by C and R_C in parallel also has a high Q , Q_{0C} . These two physical elements are connected in series. Show that Q_0 for the resultant series circuit is $Q_0 = Q_{0L}Q_{0C}/(Q_{0L} + Q_{0C})$.
- ◆65 For the circuit shown in Fig. 15-41a, determine: (a) the approximate resonant frequency and (b) the effective Q_0 .
- 66 The network shown in Fig. 15-41b has some surprising characteristics. Find $Z(s)$. What is the bandwidth?

- ◆67 The basic circuit of a vacuum-tube radio-frequency amplifier is shown in Fig. 15-42*a*. In Fig. 15-42*b* the pentode has been replaced by its Norton equivalent circuit (valid only for relatively small voltages and currents). Find $E_{\text{out}}/E_{\text{in}}$ at resonance, and determine the half-power bandwidth (over which $|E_{\text{out}}/E_{\text{in}}| \geq 0.707$ times its resonant value).
- 68 Find the bandwidth of the network shown in Fig. 15-43*a*.
- 69 For each network shown in Fig. 15-43, it is desired that the impedance be increased by a factor of 20 at all frequencies. Determine the new element values in: ◆(a) Fig. 15-43*a* and (b) Fig. 15-43*b*.
- 70 For each network shown in Fig. 15-43, it is desired that the same impedance be obtained at a frequency 100 times greater. Determine the new element values in: ◆(a) Fig. 15-43*a* and (b) Fig. 15-43*b*.
- 71 For each network shown in Fig. 15-43, it is desired that an impedance 50 times as large be obtained at a frequency 20 times greater. Determine the new element values in: ◆(a) Fig. 15-43*a* and (b) Fig. 15-43*b*.
- 72 For each $Z(s)$ given below: (a) scale $Z(s)$ in magnitude by a factor of 20; (b) scale $Z(s)$ in frequency by a factor of 10; (c) scale $Z(s)$ to obtain an impedance 50 times greater at a frequency 20 times greater.

$$Z_1(s) = s + 1 \quad Z_2(s) = \frac{10s^2 + 70s + 60}{s^2 + 4s} \quad Z_3(s) = \frac{s^3 + 6s^2 + 10s}{s^2 + 3s + 5}$$

- 73 A voltage source E is connected in series with a 4-ohm resistor and the parallel combination of a 1-ohm resistor and a 0.1-farad capacitor; the voltage E_0 is across the capacitor. (a) Determine E_0/E as a function of s . (b) If each element now has its impedance scaled by a factor of 5 in magnitude, find E_0/E . (c) If each element of the original network now has its impedance scaled in frequency by a factor of 10, find E_0/E . (d) Do the scaling operations of parts b and c result in scaling E_0/E by factors of 5 and 10 in magnitude and frequency, respectively?

Part
Five:
Special
Topics

Chapter *16* *Magnetically Coupled Circuits*

16-1 INTRODUCTION

Several hundred pages ago the inductor was introduced as a circuit element and defined in terms of the voltage across it and the time rate of change of the current through it. Strictly speaking, our definition was of “self-inductance,” but, loosely speaking, “inductance” is the commonly used term. Now we need to consider mutual inductance, a property which is associated mutually with two or more coils which are physically close together. A circuit element called the “mutual inductor” does not exist; furthermore, mutual inductance is not a property which is associated with a single pair of terminals, but instead is defined in terms of two pairs of terminals.

Mutual inductance results through the presence of a common magnetic flux which links two coils. It may be defined in terms of this common magnetic flux, just as we might have defined self-inductance in terms of the magnetic flux about the single coil. However, we have agreed to confine our attention to circuit concepts, and such quantities as magnetic flux and flux linkages are mentioned only in passing; we cannot define these quantities easily or accurately at this time, and we must accept them as nebulous concepts which are useful in establishing some background only.

The physical device whose operation is based inherently on mutual inductance is the transformer. The 60-cps power systems use many transformers, ranging in size from the dimensions of a living room to those of the living-room wastebasket. They are used to change the magnitude of the voltage, increasing it for more economical transmission, and then decreasing it for safer operation of home or industrial electrical equipment. Most radios contain one or more transformers, as do television receivers, audio systems, some telephones, automobiles, and electrified railroads (Pennsylvania and Lionel both).

We must next define mutual inductance and study the methods whereby its effects are included in the circuit equations. We shall conclude with a study of

the important characteristics of an air-core transformer and an important approximation to a good iron-core transformer which is known as an ideal transformer. A more detailed analysis of the general iron-core transformer may be undertaken in a subsequent course.

16-2 MUTUAL INDUCTANCE

When we defined inductance, we did so by specifying the relationship between the terminal voltage and current,

$$e(t) = L \frac{di(t)}{dt}$$

We did learn, however, that the physical basis for such a current-voltage characteristic rests upon (1) the production of a magnetic flux by a current, the flux being proportional to the current in linear inductors; and (2) the production of a voltage by the time-varying magnetic field, the voltage being proportional to the time rate of change of the magnetic field or the magnetic flux. The proportionality between voltage and time rate of change of current thus becomes evident.

Mutual inductance results from a slight extension of this same argument. A current flowing in one coil establishes a magnetic flux about that coil and also about a second coil which is in its vicinity; the time-varying flux surrounding the second coil produces a voltage across the terminals of this second coil; this voltage is proportional to the time rate of change of the current flowing through the first coil. Figure 16-1a shows a simple model of two coils L_1 and L_2 sufficiently close together that the flux produced by a current $i_1(t)$ flowing through L_1 establishes an open-circuit voltage $e_2(t)$ across the terminals of L_2 . Without considering the proper algebraic sign for the relationship, we define the *coefficient of mutual inductance*, or simply *mutual inductance* M_{21} ,

$$e_2(t) = M_{21} \frac{di_1(t)}{dt} \quad (16-1)$$

Fig. 16-1 (a) A current i_1 at L_1 produces an open-circuit voltage e_2 at L_2 .
(b) A current i_2 at L_2 produces an open-circuit voltage e_1 at L_1 .

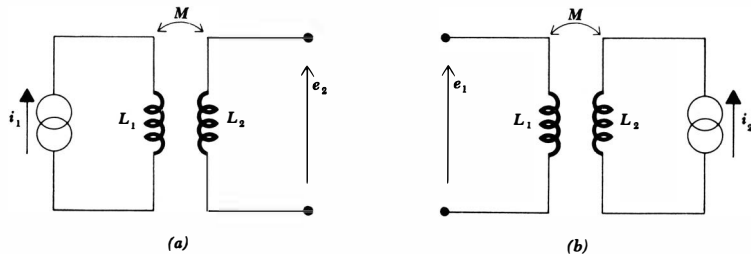

The order of the subscripts on M_{21} indicates that a voltage response is produced at L_2 by a current source at L_1 . If the system is reversed, as indicated in Fig. 16-1*b*, and a voltage response is produced at L_1 by a current source at L_2 , then we have

$$e_1(t) = M_{12} \frac{di_2(t)}{dt} \quad (16-2)$$

Two coefficients of mutual inductance are not necessary, however; we shall use energy relationships a little later to prove that M_{12} and M_{21} are equal. Thus, $M_{12} = M_{21} = M$. The existence of mutual coupling between two coils is indicated by a double-headed arrow, as shown in Fig. 16-1*a* and *b*.

Mutual inductance is measured in henrys and, like resistance, inductance, and capacitance, is always positive.¹ The voltage $M di/dt$, however, may appear as either a positive or a negative quantity in the same way that $e = -iR$ is useful.

The inductor is a two-terminal element, and we are able to use the passive sign convention in order to select the correct sign for the voltage $L di/dt$, $j\omega LI$, or sLI . If the current enters the terminal at which the voltage arrowhead is located, then the positive sign is used. Mutual inductance, however, cannot be treated in exactly the same way because four terminals are involved. The choice of a correct sign is established by use of one of several possibilities which include the "dot convention," or an extension of the dot convention which involves the use of a larger variety of special symbols, or by an examination of the particular way in which each coil is wound. We shall use the dot convention and merely look briefly at the physical construction of the coils; the use of other special symbols is not necessary when only two coils are coupled.

The dot convention makes use of a large dot placed at one end of each of the two coils which are mutually coupled. A current entering the dotted terminal of one coil produces an open-circuit voltage between the terminals of the second coil which is sensed in the direction indicated by a voltage arrowhead at the dotted terminal of this second coil. Thus, in Fig. 16-2*a*, i_1 enters the dotted terminal of L_1 , e_2 is sensed by a voltage arrowhead at the dotted terminal of L_2 , and thus $e_2 = M di_1/dt$. We have found previously that it is often possible to select voltages or currents throughout a circuit so that the passive sign convention is everywhere satisfied; the same situation arises with mutual coupling. For example, it may be more convenient to represent e_2 by a voltage arrowhead at the undotted terminal, as shown in Fig. 16-2*b*: then $e_2 = -M di_1/dt$. Currents which enter the dotted terminal are also not always available, as indicated by Fig. 16-2*c* and *d*. Such a current provides a voltage which is positive at the undotted terminal of the second coil.

We have as yet considered only a mutual voltage present across an *open-circuited* coil. In general, a nonzero current will be flowing in each of the two coils, and a mutual voltage will be produced in each coil because of the current flow-

¹ Mutual inductance is not universally assumed to be positive. It is particularly convenient to allow it to "carry its own sign" when three or more coils are involved and each coil interacts with each other coil. We shall restrict our attention to the more important simple case of two coils.

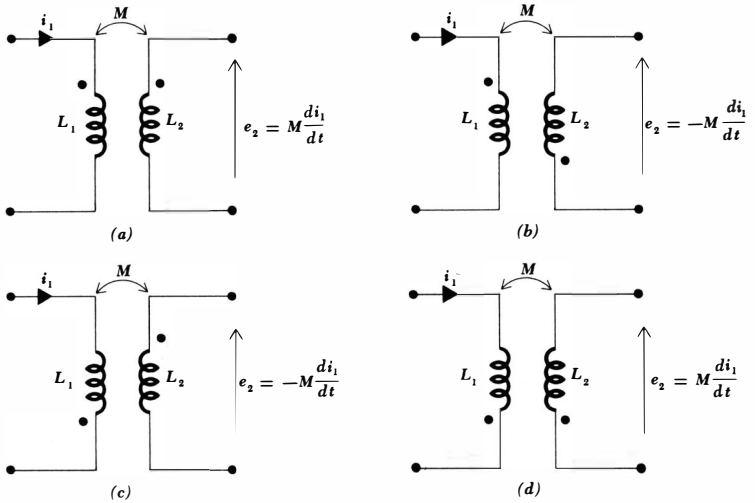
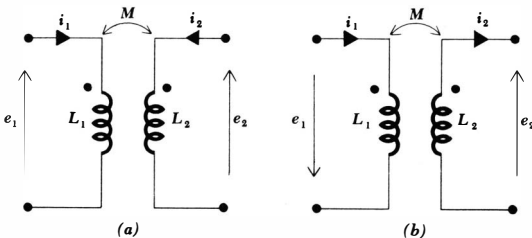

Fig. 16-2 Current entering the dotted terminal of one coil produces a voltage which is sensed positively at the dotted terminal of the second coil. Current entering the undotted terminal of one coil produces a voltage which is sensed positively at the undotted terminal of the second coil.

Fig. 16-3 (a) Since the pairs e_1, i_1 and e_2, i_2 each satisfy the passive sign convention, the voltages of self-induction are both positive; since i_1 and i_2 each enter dotted terminals, and since e_1 and e_2 are both positively sensed at the dotted terminals, the voltages of mutual induction are also both positive. (b) Since the pairs e_1, i_1 and e_2, i_2 are not sensed according to the passive sign convention, the voltages of self-induction are both negative; since i_1 enters the dotted terminal and e_2 is positively sensed at the dotted terminal, the mutual term of e_2 is positive; and since i_2 enters the undotted terminal and e_1 is positively sensed at the undotted terminal, the mutual term of e_1 is also positive.



ing in the other coil. *This mutual voltage is present independently of any voltage of self-induction.* In other words, the voltage across the terminals of L_1 will be composed of two terms $L_1 di_1/dt$ and $M di_2/dt$, each carrying a sign depending on the current directions, the assumed voltage sense, and the placement of the two dots. In the portion of a circuit drawn in Fig. 16-3a, currents i_1 and i_2 are shown, each arbitrarily assumed entering the dotted terminal. The voltage across L_1 is thus composed of two parts,

$$e_1 = L_1 \frac{di_1}{dt} + M \frac{di_2}{dt}$$

as is the voltage across L_2 ,

$$e_2 = L_2 \frac{di_2}{dt} + M \frac{di_1}{dt}$$

In Fig. 16-3b the currents and voltages are not selected with the object of obtaining all positive terms for e_1 and e_2 . By inspecting only the arrows representing i_1 and e_1 , it is apparent that the passive sign convention is not satisfied and the sign of $L_1 di_1/dt$ must therefore be negative. An identical conclusion is reached for the term $L_2 di_2/dt$. The mutual term of e_2 is signed by inspecting the direction of i_1 and e_2 ; since i_1 enters the dotted terminal and e_2 is positive at the dotted terminal, the sign of $M di_1/dt$ must be positive. Finally, i_2 enters the undotted terminal of L_2 and e_1 is positive at the undotted terminal of L_1 ; hence, the mutual portion of e_1 , $M di_2/dt$, must also be positive. Thus, we have

$$e_1 = -L_1 \frac{di_1}{dt} + M \frac{di_2}{dt} \quad e_2 = -L_2 \frac{di_2}{dt} + M \frac{di_1}{dt}$$

The same considerations lead to identical choices of signs for excitation at a complex frequency s ,

$$\mathbf{E}_1 = -sL_1\mathbf{I}_1 + sM\mathbf{I}_2 \quad \mathbf{E}_2 = -sL_2\mathbf{I}_2 + sM\mathbf{I}_1$$

or at a real frequency $s = j\omega$,

$$\mathbf{E}_1 = -j\omega L_1\mathbf{I}_1 + j\omega M\mathbf{I}_2 \quad \mathbf{E}_2 = -j\omega L_2\mathbf{I}_2 + j\omega M\mathbf{I}_1$$

Before we apply the dot convention to the analysis of a numerical example, we can gain a more complete understanding of the dot symbolism by looking at the physical basis for the convention. The meaning of the dots is now interpreted in terms of magnetic flux. Two coils are shown wound on a cylindrical form in Fig. 16-4, and the direction of each winding is evident. Let us assume that the current i_1 is positive and increasing with time. The magnetic flux that i_1 produces within the form has a direction which may be found by the right-hand rule: when the right hand is wrapped around the coil with the fingers pointing in the direction of current flow, the thumb indicates the direction of the flux within the coil. Thus i_1 produces a flux which is directed downward; since i_1 is increasing with time, the flux, which is proportional to i_1 , is also increasing with time. Turning now to the second coil, let us also think of i_2 as positive and

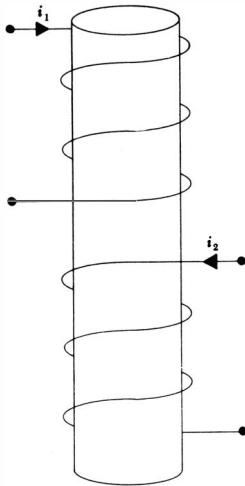

Fig. 16-4 The physical construction of two mutually coupled coils is shown. From a consideration of the direction of magnetic flux produced by each coil, it is shown that dots may be placed either on the upper terminal of each coil or on the lower terminal of each coil.

increasing; the application of the right-hand rule shows that i_2 also produces a magnetic flux which is directed downward and is increasing. In other words, the assumed currents i_1 and i_2 produce *additive* fluxes.

The voltage across the terminals of any coil results from the time rate of change of the flux linking that coil. The voltage across the terminals of the first coil is therefore greater with i_2 flowing than it would be if i_2 were zero. Thus i_2 induces a voltage in the first coil which has the same sense as the self-induced voltage in that coil. The sign of the self-induced voltage is known from the passive sign convention, and the sign of the mutual voltage is thus obtained.

The dot convention merely enables us to suppress the physical construction of the coils by placing a dot at one terminal of each coil such that currents entering dot-marked terminals produce additive fluxes. It is apparent that there are always two possible locations for the dots, because both dots may always be moved to the other ends of the coils and additive fluxes will still result.

The alternative method of selecting the correct signs for the mutual terms therefore consists of first noting whether or not both currents enter dot-marked terminals. If they do, then the sign of the mutual voltage at each coil is the same as the sign of the self-induced voltage at that same coil. The same result occurs if both currents leave dot-marked terminals. However, if neither of these conditions occurs, then subtractive fluxes result and the sign of the mutual voltage at each coil is the opposite of the sign of the self-induced voltage at that same coil.

In the example of Fig. 16-3*b*, the currents do not both enter either the dotted or undotted terminals, and the signs of the mutual terms must be the opposite of the signs of the self-induced terms. The passive sign convention indicates that both of the self-induced voltages carry negative signs, and thus both of the mutual voltages are positive. This agrees with the previous set of equations

487 **Magnetically Coupled Circuits**

obtained for this circuit; either method may be used to find the correct signs for the $M di/dt$ terms.

Let us now apply these methods to the analysis of the circuit outlined in Fig. 16-5. We desire the ratio of the output voltage across the 400-ohm resistor to the source voltage. Two conventional mesh currents are established, and Kirchhoff's voltage law must next be applied to each mesh. In the left mesh, the sign of the mutual term may be determined, for example, by applying the dot convention directly. Since I_2 leaves the dot-marked terminal of L_2 , the mutual voltage across L_1 must have the arrowhead at the undotted terminal. Thus,

$$I_1(1 + j10) - j90I_2 = 10$$

For variety, the sign of the mutual term in the second mesh may be determined by another method. Since I_1 enters the dot-marked terminal while I_2 leaves the dot-marked terminal, the mutual term in each mesh must have the opposite sign from the self-inductance term. Thus, we may write

$$I_2(400 + j1000) - j90I_1 = 0$$

The two equations may be solved by determinants (or a simple elimination of I_1),

$$I_2 = \frac{\begin{vmatrix} 1 + j10 & 10 \\ -j90 & 0 \end{vmatrix}}{\begin{vmatrix} 1 + j10 & -j90 \\ -j90 & 400 + j1000 \end{vmatrix}}$$

and $I_2 = 0.1725 / -16.7^\circ$

and thus

$$\frac{E_2}{E_1} = \frac{400(0.1725 / -16.7^\circ)}{10}$$

or $\frac{E_2}{E_1} = 6.90 / -16.7^\circ$

The output voltage is greater in magnitude than the input voltage, and thus a voltage gain is possible with mutual coupling just as it is in a resonant circuit. The voltage gain available in this circuit, however, is present over a relatively wide range of frequency; in a moderately high Q resonant circuit, the voltage step-up is proportional to the Q and occurs only over a range of frequency which

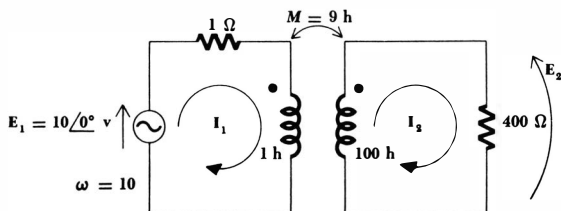
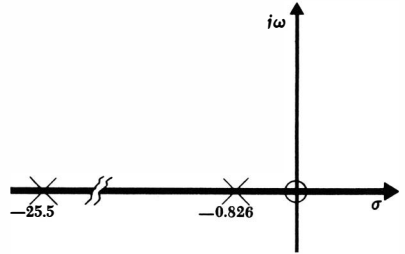

Fig. 16-5 A circuit containing mutual inductance in which the voltage ratio E_2/E_1 is desired.

Fig. 16-6 A pole-zero plot of the transfer function E_2/E_1 for the circuit shown in Fig. 16-5. The plot is useful in showing that the magnitude of the transfer function is relatively large from $\omega = 1$ or 2 to $\omega = 15$ or 20.



is inversely proportional to Q . Let us see if this point can be made clear by reference to the complex plane.

We may find $I_2(s)$ for this particular circuit,

$$I_2(s) = \frac{\begin{vmatrix} 1 + s & E_1 \\ -9s & 0 \end{vmatrix}}{\begin{vmatrix} 1 + s & -9s \\ -9s & 400 + 100s \end{vmatrix}} = \frac{9sE_1}{19s^2 + 500s + 400}$$

and thus obtain the ratio of output to input voltage as a function of s ,

$$\frac{E_2}{E_1} = \frac{3600s}{19s^2 + 500s + 400} = 189.5 \frac{s}{(s + 0.826)(s + 25.5)}$$

The pole-zero plot of this transfer function is shown in Fig. 16-6. The location of the pole at $s = -25.5$ is distorted in order to show both poles clearly; the

Fig. 16-7. The voltage gain $|E_2/E_1|$ of the circuit shown in Fig. 16-5 is plotted as a function of ω . The voltage gain is greater than 5 from about $\omega = 0.75$ to about $\omega = 28$.

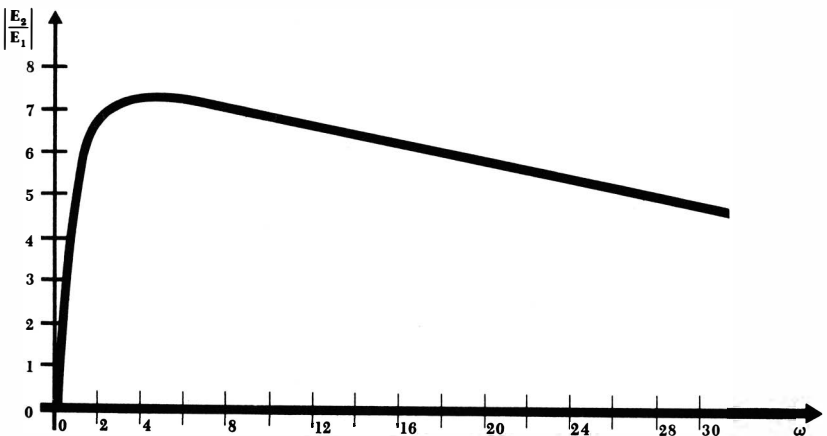

ratio of the distances of the two poles from the origin is actually about 30:1. An inspection of this plot shows that the transfer function is zero at zero frequency but that as soon as ω is greater than, say, 1 or 2 the ratio of the distances from the zero and the pole nearer the origin is essentially unity. Thus the voltage gain is affected only by the distant pole on the negative σ axis, and this distance does not increase appreciably until ω approaches 15 or 20.

These tentative conclusions are verified by the response curve of Fig. 16-7, which shows that the magnitude of the voltage gain is greater than 0.707 of its maximum value from $\omega = 0.78$ to $\omega = 26$.

The circuit is still passive, except for the voltage source, and the voltage gain must not be mistakenly interpreted as a power gain. At $\omega = 10$, the voltage gain is 6.90, but the ideal voltage source, possessing a voltage of 10 volts, delivers a total power of 8.08 watts of which only 5.95 watts reaches the 400-ohm resistor. The ratio of the output power to the source power, which we may define as the power gain, is thus 0.737.

Let us consider briefly one additional example, illustrated in Fig. 16-8. The circuit contains three meshes, and three mesh currents are assigned. Applying Kirchhoff's voltage law to the first mesh, a positive sign for the mutual term is assured by selecting ($I_3 - I_2$) as the current through the second coil. Thus,

$$5\mathbf{I}_1 + 7s(\mathbf{I}_1 - \mathbf{I}_2) + 2s(\mathbf{I}_3 - \mathbf{I}_2) = \mathbf{E}_1$$

or $(5 + 7s)\mathbf{I}_1 - 9s\mathbf{I}_2 + 2s\mathbf{I}_3 = \mathbf{E}_1$ (16-3)

The second mesh requires two self-inductance terms and two mutual-inductance terms; the equation cannot be written carelessly. We obtain

$$7s(\mathbf{I}_2 - \mathbf{I}_1) + 2s(\mathbf{I}_2 - \mathbf{I}_3) + \frac{1}{s}\mathbf{I}_2 + 6s(\mathbf{I}_2 - \mathbf{I}_3) + 2s(\mathbf{I}_2 - \mathbf{I}_1) = 0$$

or $-9s\mathbf{I}_1 + \left(17s + \frac{1}{s}\right)\mathbf{I}_2 - 8s\mathbf{I}_3 = 0$ (16-4)

Finally, for the third mesh

$$6s(\mathbf{I}_3 - \mathbf{I}_2) + 2s(\mathbf{I}_1 - \mathbf{I}_2) + 3\mathbf{I}_3 = 0$$

or $2s\mathbf{I}_1 - 8s\mathbf{I}_2 + (3 + 6s)\mathbf{I}_3 = 0$ (16-5)

Equations (16-3) to (16-5) may be solved by any of the conventional methods.

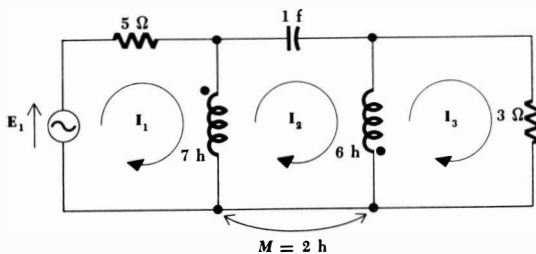

Fig. 16-8 A three-mesh circuit involving mutual coupling.

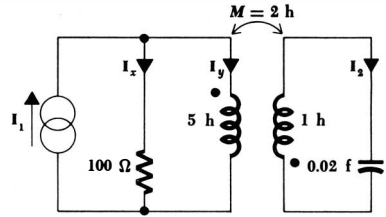

Fig. 16-9. See Drill Probs. 16-2 and 16-3.

Drill Problems

16-1 In the circuit shown in Fig. 16-3a, assume that $L_1 = 10$ henrys, $L_2 = 1$ henry, and $M = 3$ henrys. (a) If $i_{s1} = 0.4 \cos 60t$ amp is a current source applied to the left terminal pair, and the right terminal pair is left open-circuited, find e_2 . (b) Find e_1 . (c) Now assume that a voltage source $e_{s1} = 200 \sin 60t$ volts is applied at the left terminal pair. Find e_{2oc} .

Ans. $-240 \sin 60t$ volts; $60 \sin 60t$ volts; $-72 \sin 60t$ volts

16-2 In the circuit shown in Fig. 16-9, the forced response is desired for an exponential forcing function $i_1(t) = 0.2e^{-10t}$ amp. Find: (a) I_x ; (b) I_y ; (c) I_2 .

Ans. -0.0609 amp; 0.261 amp; -0.348 amp

16-3 In the circuit shown in Fig. 16-9, change the capacitor to 1 farad and the resistor to 3 ohms. After finding the $Z_{in}(s)$ offered to the current source, determine the numerical values of the three poles of this impedance.

Ans. -1 ; $-1 + j\sqrt{2}$; $-1 - j\sqrt{2}$

16-4 In the circuit shown in Fig. 16-10, mutual coupling exists only between the 2- and 3-henry inductors. Three branch currents are assumed. Write the Kirchhoff voltage equation for each mesh directly in terms of these branch currents.

Ans. $(2s + 5/s)I_1 - sI_2 - sI_3 = E_1$; $-sI_1 - 2sI_2 + (4 + 3s)I_3 = 0$;
 $-sI_1 + 8sI_2 - 2sI_3 = 0$

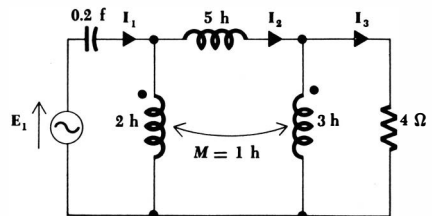

Fig. 16-10 See Drill Prob. 16-4.

16-3 ENERGY CONSIDERATIONS

Let us now consider the energy stored in a pair of mutually coupled inductors. The results will be useful in several different ways. We shall first justify our assumption that $M_{12} = M_{21}$, and we may then determine the maximum possible value of the mutual inductance between two given inductors. Finally, we shall provide ourselves with a basis from which it is possible to establish the initial conditions in magnetically coupled circuits, although we shall consider only the more elementary cases.

A pair of coupled coils is shown in Fig. 16-3*a* with currents, voltages, and polarity dots indicated. Let us first show that reciprocity is valid, or that $M_{12} = M_{21}$. In order to do so, we shall begin by letting all currents and voltages be zero, thus establishing zero initial energy storage in the network. We first open-circuit the right terminal pair and increase i_1 from zero to some constant value I_1 . The power entering the network from the left at any instant is

$$e_1 i_1 = L_1 \frac{di_1}{dt} i_1$$

and that entering from the right is

$$e_2 i_2 = 0$$

since $i_2 = 0$.

The energy stored within the network when $i_1 = I_1$ is thus

$$\int_0^{I_1} e_1 i_1 dt = \int_0^{I_1} L_1 i_1 di_1 = \frac{1}{2} L_1 I_1^2$$

We now hold i_1 constant, $i_1 = I_1$, and let i_2 change from zero to some constant value I_2 . The energy delivered from the right source is thus

$$\int_{t_1}^{t_2} e_2 i_2 dt = \int_0^{I_2} L_2 i_2 di_2 = \frac{1}{2} L_2 I_2^2$$

However, even though the value of i_1 remains constant, the left source also delivers energy to the network during this time interval,

$$\begin{aligned} \int_{t_1}^{t_2} e_1 i_1 dt &= \int_{t_1}^{t_2} M_{12} \frac{di_2}{dt} i_1 dt \\ &= M_{12} I_1 \int_0^{I_2} di_2 \\ &= M_{12} I_1 I_2 \end{aligned}$$

The total energy stored in the network when both i_1 and i_2 have reached a constant value is

$$W_{\text{total}} = \frac{1}{2} L_1 I_1^2 + \frac{1}{2} L_2 I_2^2 + M_{12} I_1 I_2$$

Now we may establish the same final currents in this network by allowing the currents to reach their final values in the reverse order, that is, first increasing i_2 from zero to I_2 and then holding i_2 constant while i_1 increases from zero to I_1 .

If the total energy stored is calculated for this experiment, the result is found to be

$$W_{\text{total}} = \frac{1}{2}L_1I_1^2 + \frac{1}{2}L_2I_2^2 + M_{21}I_1I_2$$

The only difference is the interchange of the mutual inductances M_{21} and M_{12} . The initial and final conditions in the network are the same, however, and the two values of the stored energy must be identical. Thus,

$$M_{12} = M_{21} = M$$

$$\text{and } W = \frac{1}{2}L_1I_1^2 + \frac{1}{2}L_2I_2^2 + MI_1I_2 \quad (16-6)$$

If one current enters a dot-marked terminal while the other leaves a dot-marked terminal, the sign of the mutual energy term is reversed:

$$W = \frac{1}{2}L_1I_1^2 + \frac{1}{2}L_2I_2^2 - MI_1I_2 \quad (16-7)$$

Although Eqs. (16-6) and (16-7) were derived by treating the final values of the two currents as constants, it is apparent that these "constants" may have any value, and the energy expressions correctly represent the energy stored when the *instantaneous* values of i_1 and i_2 are I_1 and I_2 , respectively. In other words, lowercase symbols might just as well be used,

$$w(t) = \frac{1}{2}L_1[i_1(t)]^2 + \frac{1}{2}L_2[i_2(t)]^2 \pm M[i_1(t)][i_2(t)] \quad (16-8)$$

The only assumption upon which Eq. (16-8) is based is the logical establishment of a zero-energy reference level when both currents are zero.

Equation (16-8) may now be used to establish an upper limit for the value of M . Since $w(t)$ represents the energy stored within a *passive* network, it cannot be negative for any values of i_1 , i_2 , L_1 , L_2 , or M . Let us assume that i_1 and i_2 are either both positive or both negative; their product is therefore positive. From Eq. (16-8), the only case in which the energy could possibly be negative is

$$w = \frac{1}{2}L_1i_1^2 + \frac{1}{2}L_2i_2^2 - Mi_1i_2$$

which we may write, by completing the square,

$$w = \frac{1}{2}(\sqrt{L_1}i_1 - \sqrt{L_2}i_2)^2 + \sqrt{L_1L_2}i_1i_2 - Mi_1i_2$$

Now the energy cannot be negative; the right side of this equation therefore cannot be negative. The first term, however, may be as small as zero, and thus the sum of the last two terms cannot be negative. Hence,

$$\sqrt{L_1L_2} \geq M$$

$$\text{or } M \leq \sqrt{L_1L_2} \quad (16-9)$$

There is, therefore, an upper limit to the possible magnitude of the mutual inductance; it can be no larger than the geometric mean of the inductances of the two coils between which the mutual inductance exists. Although we have derived this inequality on the assumption that i_1 and i_2 carried the same algebraic sign, a similar development is possible if the signs are opposite; it is only necessary to select the positive sign in Eq. (16-8).

We might also have demonstrated the truth of Eq. (16-9) from a physical consideration of the magnetic coupling; if we think of i_2 as being zero and the current i_1 as establishing the magnetic flux linking both L_1 and L_2 , it is apparent that the flux linking L_2 cannot be greater than the flux linking L_1 , which represents the total flux. Qualitatively, then, there is an upper limit to the magnitude of the mutual inductance possible between two given inductors. For example, if $L_1 = 1$ henry and $L_2 = 10$ henrys, then $M \leq 3.16$ henrys.

The degree to which M approaches its maximum value is exactly described by the coefficient of coupling. We define the *coefficient of coupling*, symbolized as k ,

$$k = \frac{M}{\sqrt{L_1 L_2}} \quad (16-10)$$

It is evident that

$$k \leq 1 \quad \text{and} \quad k \geq 0$$

The larger values of the coefficient of coupling are obtained with coils which are physically closer, which are wound or oriented to provide a larger common magnetic flux, or which are provided with a common path through a material which serves to concentrate and localize the magnetic flux (a high-permeability material). Coils having a large coefficient of coupling are said to be tightly coupled.

The complete response of a circuit possessing mutual coupling must of course be made up of the sum of a forced and a natural response. We are now equipped to find the forced response for the more familiar forcing functions, and we shall consider this portion of the response in detail for several interesting circuits in the remainder of this chapter. If we can find the forced response, then we certainly can locate the poles or zeros of any immittance function associated with the circuit. This knowledge of the pole-zero locations then enables us to establish the functional form of the natural response. The remaining problem, the determination of the arbitrary constants through the values of the initial conditions in the network, is not as easily resolved with the analytical methods we possess. The use of the initial conditions turns out to be much more straightforward when the operational method of the Laplace transform is employed, and this topic is one which should be studied in some subsequent course. Rather than make a simple problem appear difficult, we shall therefore largely neglect the transient analysis of mutually coupled circuits. Let us consider only the single straightforward problem of finding the complete response when a constant voltage is suddenly applied to one coil while the second coil is connected to a resistive load.

The circuit to be analyzed is shown in Fig. 16-11; the currents i_1 and i_2 are desired. The forced response may be determined readily, for it will have the form of the forcing function, that is, a constant times $u(t)$. Since neither current is changing, there can be no mutual voltage. Thus, i_2 is flowing in a source-free circuit and this *forced* response must be zero. The 10-volt source

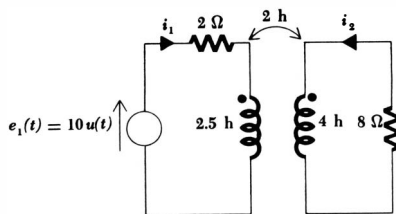

Fig. 16-11 A circuit containing mutual coupling for which the complete response is desired.

present in the first mesh, however, produces a forced response of 5 amp for i_1 . Thus,

$$i_{1f} = 5u(t) \quad i_{2f} = 0$$

The form of the natural response is now obtained by determining the zeros of the impedance offered to the source. After writing the Kirchhoff voltage equation about each mesh,

$$\begin{aligned} (2 + 2.5s)\mathbf{I}_1 + 2s\mathbf{I}_2 &= \mathbf{E}_1 \\ 2s\mathbf{I}_1 + (8 + 4s)\mathbf{I}_2 &= 0 \end{aligned}$$

we determine \mathbf{Z}_{in} as the ratio of \mathbf{E}_1 to \mathbf{I}_1 ,

$$\mathbf{Z}_{in} = 2 + 2.5s - \frac{4s^2}{8 + 4s}$$

$$\text{or} \quad \mathbf{Z}_{in} = 1.5 \frac{(s + \frac{2}{3})(s + 4)}{s + 2}$$

and thus the form of the natural response is established for both i_1 and i_2 ,

$$\begin{aligned} i_{1n} &= A_1 e^{-2t/3} + B_1 e^{-4t} \\ i_{2n} &= A_2 e^{-2t/3} + B_2 e^{-4t} \end{aligned}$$

The complete responses are therefore

$$i_1 = 5u(t) + A_1 e^{-2t/3} + B_1 e^{-4t} \quad (16-11)$$

$$i_2 = A_2 e^{-2t/3} + B_2 e^{-4t} \quad (16-12)$$

We must next establish the initial values of the two currents and their first derivatives from physical considerations. There is no energy stored initially in the circuit, and there can be no discontinuous change in the stored energy without the presence of an impulse source. Thus, the energy stored remains zero at $t = 0^+$, and this requires that both i_1 and i_2 be zero at $t = 0^+$. The initial values of the two derivatives are most easily found by using the time-domain statements of Kirchhoff's voltage law for each mesh:

$$2i_1 + 2.5 \frac{di_1}{dt} + 2 \frac{di_2}{dt} = 10u(t)$$

$$2 \frac{di_1}{dt} + 8i_2 + 4 \frac{di_2}{dt} = 0$$

495 Magnetically Coupled Circuits

At $t = 0^+$, we have

$$0 + 2.5 \left. \frac{di_1}{dt} \right|_{0^+} + 2 \left. \frac{di_2}{dt} \right|_{0^+} = 10$$

$$2 \left. \frac{di_1}{dt} \right|_{0^+} + 0 + 4 \left. \frac{di_2}{dt} \right|_{0^+} = 0$$

Solving simultaneously,

$$\left. \frac{di_1}{dt} \right|_{0^+} = \frac{20}{3} \quad \left. \frac{di_2}{dt} \right|_{0^+} = -\frac{10}{3}$$

Taking the derivative of Eqs. (16-11) and (16-12) and evaluating at $t = 0^+$, we therefore find

$$\left. \frac{di_1}{dt} \right|_{0^+} = \frac{20}{3} = -\frac{2A_1}{3} - 4B_1$$

$$\left. \frac{di_2}{dt} \right|_{0^+} = -\frac{10}{3} = -\frac{2A_2}{3} - 4B_2$$

Since each current is also initially zero,

$$A_1 + B_1 + 5 = 0 \quad A_2 + B_2 = 0$$

These last four equations may be solved easily for the four arbitrary constants. When the results are inserted in Eqs. (16-11) and (16-12), we obtain

$$i_1 = 5u(t) - 4\epsilon^{-2t/3} - \epsilon^{-4t}$$

$$i_2 = -\epsilon^{-2t/3} + \epsilon^{-4t}$$

The source current is quite similar to the response of the simple RL series circuit having a time constant of approximately 4 sec. The value of 4 sec, however, is determined by both resistors, both self-inductances, and the mutual inductance. The load current is a negative pulse having a maximum magnitude of about 0.6 amp, occurring about 0.5 sec after $t = 0$.

The principles on which this analysis is based are not difficult to comprehend, but one does suffer from fatigue in carrying out the analytical details. The use of the operational methods mentioned on page 493 serves to reduce greatly the number of trivial steps required, as well as to organize the solution in a more systematic fashion.

Drill Problems

16-5 Determine the energy stored in the network shown in Fig. 16-3b if $L_1 = 2$ henrys, $L_2 = 8$ henrys, $i_1 = 6$ amp, $i_2 = 3$ amp, and: (a) $k = 0$; (b) $k = 0.5$; (c) $k = 1$.

Ans. 36 joules; 0 joules; 72 joules

16-6 Two inductors $L_1 = 0.4$ henry and $L_2 = 0.1$ henry are mutually coupled, and a resistor $R_2 = 5$ ohms is connected across L_2 . Determine

the impedance offered at the terminals of L_1 at $\omega = 50$ if: (a) $k = 0$; (b) $k = 0.5$; (c) $k = 1$.

Ans. $2.5 + j 17.5$ ohms; $10 + j 10$ ohms; $j 20$ ohms

16-7 Repeat Drill Prob. 16-6 if $\omega = 50,000$.

Ans. $20 + j 0.02$ ohms; $j 20,000$ ohms; $5 + j 15,000$ ohms

16-4 THE AIR-CORE TRANSFORMER

We are now ready to apply our knowledge of magnetic coupling to an analytical description of the performance of two specific practical devices, each of which may be represented by a model containing mutual inductance. Both of the devices are *transformers*, a term which we may define as a network containing two or more coils which are deliberately coupled magnetically. In this section we shall consider the air-core transformer, which is, even in practice, a linear device finding its greatest application at radio frequencies, or higher frequencies. In the following section we shall consider the ideal transformer, which is an idealized model of a physical transformer that does *not* have an air core, but rather has a core made of some magnetic material, usually iron alloy.

In Fig. 16-12 there is shown a transformer with two mesh currents identified. The first mesh, usually containing the source, is called the *primary*, while the second mesh, usually containing the load, is known as the *secondary*. The inductors L_1 and L_2 are also referred to as the primary and secondary, respectively, of the transformer. We shall assume that the transformer is an air-core transformer. This merely infers that no magnetic material is employed to cause most of the magnetic flux produced by the primary winding to link the secondary winding. Without such material, it is difficult to achieve a coefficient of coupling greater than a few tenths. The two resistors serve to account for the resistance of the wire out of which the primary and secondary coils are wound, and any other losses.

In most applications, the air-core transformer is used with a tuned, or resonant, secondary; the primary winding is also operated often in a resonant condition by replacing the ideal voltage source by a current source in parallel with a large resistance and a capacitance. The analysis of such a single-tuned or double-tuned circuit is a fairly lengthy process, and we shall not undertake it at this time. It may be pointed out, however, that the secondary response is characterized by

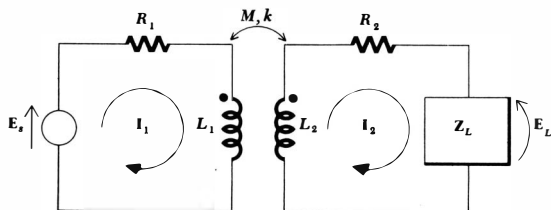

Fig. 16-12 An air-core transformer containing a source in the primary circuit and a load in the secondary circuit.

the familiar resonance curve for relatively small coefficients of coupling but that a greater control of the shape of the response curve as a function of frequency becomes possible for larger coefficients of coupling. Response curves which possess flatter tops and sharper drops on each side may be achieved in the double-tuned circuit.

Let us consider only the input impedance offered at the terminals of the primary circuit. The two mesh equations are

$$\mathbf{E}_s = \mathbf{I}_1(R_1 + sL_1) - \mathbf{I}_2sM \quad (16-13)$$

$$0 = -\mathbf{I}_1sM + \mathbf{I}_2(R_2 + sL_2 + \mathbf{Z}_L) \quad (16-14)$$

We may simplify by defining

$$\mathbf{Z}_{11} = R_1 + sL_1 \quad \mathbf{Z}_{22} = R_2 + sL_2 + \mathbf{Z}_L$$

and thus

$$\mathbf{E}_s = \mathbf{I}_1\mathbf{Z}_{11} - \mathbf{I}_2sM \quad (16-15)$$

$$0 = -\mathbf{I}_1sM + \mathbf{I}_2\mathbf{Z}_{22} \quad (16-16)$$

Solving the second equation for \mathbf{I}_2 and inserting this in the first equation enables us to find the input impedance,

$$\mathbf{Z}_{in} = \frac{\mathbf{E}_s}{\mathbf{I}_1} = \mathbf{Z}_{11} - \frac{s^2M^2}{\mathbf{Z}_{22}} \quad (16-17)$$

Before manipulating this expression any further, we can draw several exciting conclusions. In the first place, this result is independent of the location of the dots on either winding, for if either dot is moved to the other end of the coil, the result is a change in sign of each term involving M in Eqs. (16-13) to (16-16). This same effect could be obtained by replacing M by $(-M)$, and such a change cannot affect the input impedance, as Eq. (16-17) demonstrates. We also may note in Eq. (16-17) that the input impedance is simply \mathbf{Z}_{11} if the coupling is reduced to zero. As the coupling is increased from zero, the input impedance differs from \mathbf{Z}_{11} by an amount $-s^2M^2/\mathbf{Z}_{22}$, termed the *reflected impedance*. This change can be inspected more closely by letting $s = j\omega$,

$$\mathbf{Z}_{in}(j\omega) = \mathbf{Z}_{11}(j\omega) + \frac{\omega^2M^2}{R_{22} + jX_{22}}$$

and rationalizing the reflected impedance,

$$\mathbf{Z}_{in} = \mathbf{Z}_{11} + \frac{\omega^2M^2R_{22}}{R_{22}^2 + X_{22}^2} + \frac{-j\omega^2M^2X_{22}}{R_{22}^2 + X_{22}^2}$$

Since $\omega^2M^2R_{22}/(R_{22}^2 + X_{22}^2)$ must be positive, it is evident that the presence of the secondary increases the losses in the primary circuit. In other words, the presence of the secondary might be accounted for in the primary circuit by increasing the value of R_1 . Moreover, the reactance which the secondary *reflects* into the primary circuit has a sign which is opposite to that of X_{22} , the net reactance around the secondary loop. This reactance X_{22} is the sum of ωL_2 and

X_L ; it is necessarily positive for inductive loads and either positive or negative for capacitive loads, depending on the magnitude of the load reactance.

Let us consider the effects of this reflected reactance and resistance by considering the special case in which both the primary and secondary are identical series-resonant circuits. Thus, $R_1 = R_2 = R$, $L_1 = L_2 = L$, and the load impedance Z_L is produced by a capacitance C , identical to a capacitance inserted in series in the primary circuit. The series-resonant frequency of either the primary or secondary alone is thus $\omega_0 = 1/\sqrt{LC}$. At this resonant frequency, the net secondary reactance is zero, the net primary reactance is zero, and no reactance is reflected into the primary by the secondary. The input impedance is therefore a pure resistance; a resonant condition is present. At a slightly higher frequency, the net primary and secondary reactances are both inductive, and the reflected reactance is therefore capacitive. If the magnetic coupling is sufficiently large, the input impedance may once again be a pure resistance; another resonant condition is achieved, but at a frequency slightly higher than ω_0 . A similar condition will also occur at a frequency slightly below ω_0 . Each circuit alone is capacitive, the reflected reactance is inductive, and cancellation may occur.

Although we are leaping at conclusions, it seems possible that these three adjacent resonances, each similar to a series resonance, may permit a relatively large primary current to flow from the voltage source. The large primary current in turn provides a large induced voltage in the secondary circuit, and a large secondary current. The secondary current is present over a band of frequencies extending from slightly below to slightly above ω_0 , and thus a maximum response is achieved over a wider range of frequencies than is possible in a simple resonant circuit. Such a response curve is obviously desirable if the primary source is some intelligence signal containing energy distributed throughout a band of frequencies, rather than at a single frequency. Such signals are present in a-m and f-m radio, television, telemetry, radar, and all other communication systems.

It is often convenient to replace a transformer by an equivalent network in the form of a T or π . If we separate the primary and secondary resistances from the transformer, only the pair of mutually coupled inductors remains, as shown in Fig. 16-13. The differential equations describing this circuit are, once again,

$$e_1 = L_1 \frac{di_1}{dt} + M \frac{di_2}{dt} \quad (16-18)$$

$$\text{and} \quad e_2 = M \frac{di_1}{dt} + L_2 \frac{di_2}{dt} \quad (16-19)$$

The form of these two equations is familiar and may be easily interpreted in terms of mesh analysis. Let us select a clockwise i_1 and a counterclockwise i_2 so that i_1 and i_2 are exactly identifiable with the currents in Fig. 16-13. The terms $M di_2/dt$ in Eq. (16-18) and $M di_1/dt$ in Eq. (16-19) indicate that the two meshes must then have a common *self*-inductance of M henrys. Since the total induct-

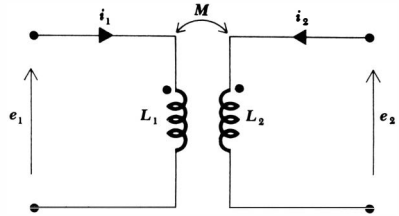

Fig. 16-13 A given transformer which is to be replaced by an equivalent network.

ance around the left mesh is L_1 , a self-inductance of $L_1 - M$ must be inserted in the first mesh, but not in the second mesh. Similarly, a self-inductance of $L_2 - M$ is required in the second mesh, but not in the first mesh. The resultant equivalent network is shown in Fig. 16-14. The equivalence is guaranteed by the identical pairs of equations relating $e_1, i_1, e_2,$ and i_2 for the two networks.

If either of the dots on the windings of the given transformer is placed on the opposite end of its coil, the sign of the mutual terms in Eqs. (16-18) and (16-19) will be negative. This is analogous to replacing M by $-M$, and such a replacement in the network of Fig. 16-14 leads to the correct equivalent for this case.

The inductances in the T equivalent are all self-inductances; no mutual inductance is present. It is possible that negative values of inductance may be obtained for the equivalent circuit, but this is immaterial if our only desire is a mathematical analysis; the actual construction of the equivalent network is of course impossible in any form involving a negative inductance.

The equivalent π network is not obtained as easily. We shall solve Eqs. (16-18) and (16-19) for i_1 and i_2 by first solving Eq. (16-19) for di_2/dt and substituting the result into Eq. (16-18),

$$e_1 = L_1 \frac{di_1}{dt} + \frac{M}{L_2} e_2 - \frac{M^2}{L_2} \frac{di_1}{dt}$$

or
$$\frac{di_1}{dt} = \frac{L_2}{L_1 L_2 - M^2} e_1 - \frac{M}{L_1 L_2 - M^2} e_2$$

or
$$\frac{di_1}{dt} = \Gamma_{11} e_1 - \Gamma_{12} e_2$$

where Γ (gamma) is a symbol designating reciprocal inductance. Thus, $\Gamma = 1/L$,

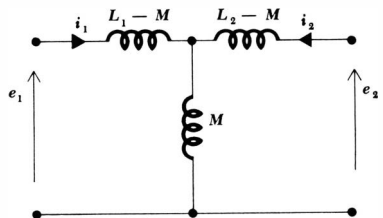

Fig. 16-14 The T equivalent of the transformer shown in Fig. 16-13.

and Γ has the dimension of reciprocal henry (which is officially designated as the *ymeh*). Here,

$$\Gamma_{11} = \frac{L_2}{L_1 L_2 - M^2} \quad \Gamma_{12} = \frac{M}{L_1 L_2 - M^2}$$

If we now integrate from 0 to t , we obtain

$$i_1 - i_1(0)u(t) = \Gamma_{11} \int_0^t e_1 dt - \Gamma_{12} \int_0^t e_2 dt \quad (16-20)$$

We now obtain a similar relationship for i_2 by solving Eq. (16-18) for di_1/dt , substituting into Eq. (16-19), isolating di_2/dt on the left side of the equation, and integrating from 0 to t :

$$i_2 - i_2(0)u(t) = -\Gamma_{12} \int_0^t e_1 dt + \Gamma_{22} \int_0^t e_2 dt \quad (16-21)$$

where

$$\Gamma_{22} = \frac{L_1}{L_1 L_2 - M^2}$$

Equations (16-20) and (16-21) may be interpreted as a pair of nodal equations. A step-current source must be installed at each node in order to provide the proper initial conditions. Reciprocal inductances obviously combine in parallel as do conductances or capacitances, and thus the reciprocal inductance extending between the two nodes is Γ_{12} , that from the first node to the reference node is $\Gamma_{11} - \Gamma_{12}$, and that from the second node to the reference node is $\Gamma_{22} - \Gamma_{12}$. Evaluating these quantities and expressing them once more as self-inductances, the equivalent π network shown in Fig. 16-15 is obtained. No magnetic coupling is present, and the initial currents in the three self-inductances are zero.

We may compensate for a reversal of either dot in the given transformer by merely changing the sign of M in the equivalent network. Also, just as we found in the equivalent T, negative self-inductances may appear in the equivalent network.

Drill Problems

16-8 In the transformer shown in Fig. 16-12, $R_1 = R_2 = 1$ ohm, $L_1 = L_2 = 1$ henry, $k = 0.1$, and $\omega = 10$. If we define the ratio of the magnitude of the input reactance to the input resistance as Q , find Q if Z_L represents: (a) an open circuit; (b) a short circuit; (c) a 0.01-farad capacitor.

Ans. 9.8; 10; 5

16-9 An air-core transformer consists of two mutually coupled inductors, each having negligible resistance. The primary terminals are identified as A and B and the secondary terminals as C and D . Terminals B and C carry dots. With the secondary open-circuited, the impedance measured at the primary terminals is that of a 3-henry inductor; with the secondary short-circuited, the impedance offered at

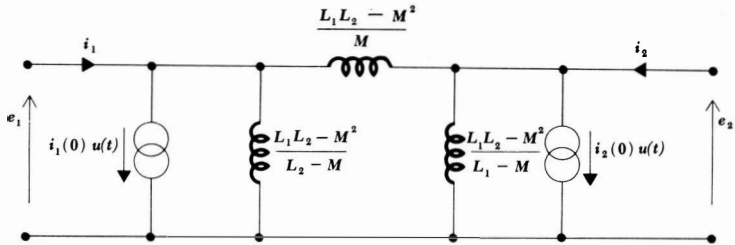

Fig. 16-15 The π network which is equivalent to the transformer shown in Fig. 16-13.

the primary terminals is that of a 2.9-henry inductor; and with the primary open-circuited, the impedance seen at the secondary terminals is that of a 10-henry inductor. Find: (a) L_{AB} ; (b) L_{CD} ; (c) M .

Ans. 10 henrys; 1 henry; 3 henrys

16-10 With reference to the coils described in Drill Prob. 16-9: (a) find the inductance offered at terminals C-D if A is connected to B; (b) find L_{AD} if B is connected to C; (c) find L_{AC} if B is connected to D.

Ans. 9.67 henrys; 11 henrys; 15 henrys

16-11 The T equivalent of an air-core transformer contains the three inductors, in order from left to right, of 6, 1, and 7 henrys. Find: (a) L_1 ; (b) L_2 ; (c) M .

Ans. 8 henrys; 1 henry; 7 henrys

16-12 The π equivalent of an air-core transformer contains the three inductors, in order from left to right, of 6, 1, and 7 henrys. Find: (a) L_1 ; (b) L_2 ; (c) M .

Ans. 3 henrys; 3.5 henrys; 3.43 henrys

16-5 THE IDEAL TRANSFORMER

An ideal transformer is a useful approximation of a very tightly coupled transformer in which the coefficient of coupling is almost unity and both the primary and secondary inductive reactances are extremely large in comparison with the terminating impedances. These characteristics are closely approached by most well-designed iron-core transformers over a reasonable range of frequencies for a reasonable range of terminal impedances. The approximate analysis of a circuit containing an iron-core transformer may be achieved very simply by replacing that transformer by an ideal transformer; the ideal transformer may be thought of as a first-order model of an iron-core transformer.

One new concept arises with the ideal transformer, the *turns ratio* a . The self-inductance of either the primary or secondary coil is proportional to the square of the number of turns of wire forming the coil. This relationship is valid only if all the flux established by the current flowing in the coil links all the turns. In order to develop this result logically, it is necessary to utilize magnetic-field concepts, a subject which is not included in our discussion of circuit analysis. However, a qualitative argument may suffice. If a current I flows through a coil of N turns, then N times the magnetic flux of a single-turn coil will be produced. If we think of the N turns as being coincident, then all the flux certainly links all the turns. As the current and flux change with time, a voltage is then induced *in each turn* which is N times larger than that caused by a single-turn coil. Finally, the voltage induced *in the N -turn coil* must be N^2 times the single-turn voltage. Thus, the proportionality between inductance and the square of the number of turns arises. It follows that

$$\frac{L_2}{L_1} = \frac{N_2^2}{N_1^2} = a^2$$

where

$$a = \frac{N_2}{N_1}$$

Figure 16-16 shows an ideal transformer to which a secondary load and a primary source, including a source impedance, are connected. The ideal nature of the transformer is established by several conventions, the use of the vertical lines between the two coils to indicate the iron laminations present in many iron-core transformers, the unity value of the coupling coefficient, and the presence of the symbol $1:a$, suggesting a turns ratio of N_1 to N_2 .

Let us analyze this transformer in the sinusoidal steady state in order that we may interpret our assumptions in the simplest context. The two mesh equations are

$$\mathbf{E}_s = \mathbf{I}_1(\mathbf{Z}_g + j\omega L_1) - \mathbf{I}_2 j\omega M \quad (16-22)$$

$$0 = -\mathbf{I}_1 j\omega M + \mathbf{I}_2(\mathbf{Z}_L + j\omega L_2) \quad (16-23)$$

Let us first find the input impedance of an ideal transformer. Although we shall let the self-inductance of each winding become infinite, the input impedance will remain finite. By solving Eq. (16-23) for \mathbf{I}_2 and substituting into Eq. (16-22), we obtain

$$\mathbf{E}_s = \mathbf{I}_1(\mathbf{Z}_g + j\omega L_1) + \mathbf{I}_1 \frac{\omega^2 M^2}{\mathbf{Z}_L + j\omega L_2}$$

and
$$\mathbf{Z}_{\text{in}} = \mathbf{Z}_g + j\omega L_1 + \frac{\omega^2 M^2}{\mathbf{Z}_L + j\omega L_2}$$

Since $k = 1$, $M^2 = L_1 L_2$, and

$$\mathbf{Z}_{\text{in}} = \mathbf{Z}_g + j\omega L_1 + \frac{\omega^2 L_1 L_2}{\mathbf{Z}_L + j\omega L_2}$$

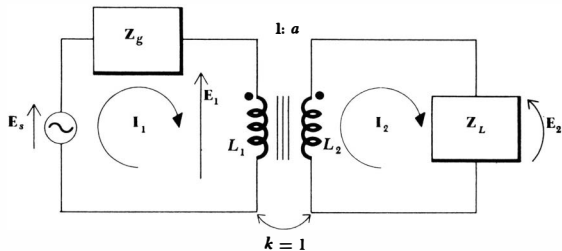

Fig. 16-16 An ideal transformer driven by a practical voltage source is connected to a general load impedance.

We now must let both L_1 and L_2 tend to infinity. Their ratio, however, remains finite, as specified by the turns ratio. Thus,

$$L_2 = a^2 L_1$$

$$\text{and } \mathbf{Z}_{\text{in}} = \mathbf{Z}_g + j\omega L_1 + \frac{\omega^2 a^2 L_1^2}{\mathbf{Z}_L + j\omega a^2 L_1}$$

Now if we let L_1 become infinite, both of the last two terms in the above expression become infinite, and the result is indeterminate. It is necessary to first combine these two terms,

$$\mathbf{Z}_{\text{in}} = \mathbf{Z}_g + \frac{j\omega L_1 \mathbf{Z}_L - \omega^2 a^2 L_1^2 + \omega^2 a^2 L_1^2}{\mathbf{Z}_L + j\omega a^2 L_1} \quad (16-24)$$

$$\text{or } \mathbf{Z}_{\text{in}} = \mathbf{Z}_g + \frac{j\omega L_1 \mathbf{Z}_L}{\mathbf{Z}_L + j\omega a^2 L_1} \quad (16-25)$$

Now as L_1 becomes infinite, it is apparent that \mathbf{Z}_{in} becomes

$$\mathbf{Z}_{\text{in}} = \mathbf{Z}_g + \frac{\mathbf{Z}_L}{a^2} \quad (16-26)$$

This result has some interesting implications, and at least one of them appears to contradict one of the characteristics of the air-core transformer. It should not, of course, since the air-core transformer represents the more general case. The input impedance of the ideal transformer is the series combination of the generator impedance and an impedance which is proportional to the load impedance, the proportionality constant being the reciprocal of the square of the turns ratio. In other words, if the load impedance is a capacitive impedance, then the input impedance is the generator impedance plus a capacitive impedance. In the air-core transformer, however, the reflected impedance suffered a sign change in its reactive part; a capacitive load led to an inductive contribution to the input impedance. The explanation of this occurrence is achieved by first realizing that \mathbf{Z}_L/a^2 is *not* the reflected impedance, although it is often loosely called by that name. The true reflected impedance is infinite in the ideal transformer; otherwise it could not “cancel” the infinite impedance of the primary inductance. This cancellation occurs in the numerator of the fraction in Eq. (16-24). The impedance \mathbf{Z}_L/a^2 represents a small term which is the

amount by which an exact cancellation does not occur. The true reflected impedance in the ideal transformer *does* change sign in its reactive part; as the primary and secondary inductances become infinite, however, the effect of the infinite primary-coil reactance and the infinite, but negative, reflected reactance of the secondary coil is one of cancellation.

The first important characteristic of the ideal transformer is therefore its capability to change the magnitude of an impedance, or to change impedance level. An ideal transformer having 100 primary turns and 10,000 secondary turns has a turns ratio of 10,000/100, or 100. Any impedance placed across the secondary then appears at the primary terminals reduced in magnitude by a factor of 100², or 10,000. A 20,000-ohm resistor looks like 2 ohms, a 200-mh inductor looks like 20 μ h, and a 100-pf capacitor looks like 1 μ f. If the primary and secondary windings are interchanged, then $a = 0.01$ and the load impedance is apparently increased in magnitude. In practice, this exact change in magnitude does not always occur, for we must remember that as we took the last step in our derivation and allowed L_1 to become infinite in Eq. (16-25), it was necessary to neglect Z_L in comparison with $j\omega L_2$. Since L_2 can never be infinite, it is evident that the ideal transformer model will begin to fail for large load impedances.

A practical example of the use of an iron-core transformer as an impedance-level changing device is in the output of an audio power amplifier which must be connected to a loudspeaker. In order to achieve maximum power transfer, we know that the resistance of the load should be equal to the internal resistance of the source; the speaker usually has an impedance magnitude (often assumed to be a resistance) of only a few ohms, while the power amplifier possesses an internal resistance of several thousand ohms. An ideal transformer in which $N_2 < N_1$ is called for. For example, if the amplifier internal impedance is 4000 ohms and the loudspeaker impedance is 8 ohms, then we desire that

$$Z_g = 4000 = \frac{Z_L}{a^2} = \frac{8}{a^2}$$

or
$$a = \frac{1}{22.4}$$

and thus

$$\frac{N_1}{N_2} = 22.4$$

There is also a simple relationship between the primary and secondary currents I_1 and I_2 in an ideal transformer. From Eq. (16-23),

$$\frac{I_2}{I_1} = \frac{j\omega M}{Z_L + j\omega L_2}$$

we allow L_2 to become infinite,

$$\frac{I_2}{I_1} = \frac{j\omega M}{j\omega L_2} = \sqrt{\frac{L_1}{L_2}}$$

$$\text{or } \frac{I_2}{I_1} = \frac{1}{a} \quad (16-27)$$

The ratio of the primary and secondary currents is the turns ratio. If we have $N_2 > N_1$, then $a > 1$, and it is apparent that the larger current flows in the winding with the fewer number of turns. In other words,

$$N_1 I_1 = N_2 I_2$$

It should also be noted that the current ratio is the negative of the turns ratio if either current is reversed or if either dot location is changed. In the example above in which an ideal transformer was used to change the impedance level to match a loudspeaker efficiently to a power amplifier, an rms current of 50 ma at 1000 cps in the primary causes an rms current of 1.12 amp at 1000 cps in the secondary. The power delivered to the loudspeaker is $1.12^2(8)$, or 10 watts, and the power delivered to the transformer by the power amplifier is $(0.05)^2 4000$, or 10 watts. The result is comforting, since the ideal transformer does not contain either an active device which can deliver power or any resistance to absorb power.

Since the power delivered to the transformer is identical with that delivered to the load, whereas the primary and secondary currents are related by the turns ratio, it is obvious that the primary and secondary voltages must also be related to the turns ratio. If we define the secondary voltage, or load voltage,

$$E_2 = I_2 Z_L$$

and the primary voltage as the voltage across L_1 , then

$$E_1 = I_1(Z_{in} - Z_0) = I_1 \frac{Z_L}{a^2}$$

The ratio of the two voltages is

$$\frac{E_2}{E_1} = a^2 \frac{I_2}{I_1}$$

$$\text{or } \frac{E_2}{E_1} = a = \frac{N_2}{N_1} \quad (16-28)$$

The ratio of the secondary to primary voltage is equal to the turns ratio. This ratio may also be negative if either voltage is reversed or either dot location is changed.

Combining the voltage and current ratios, Eqs. (16-27) and (16-28),

$$E_2 I_2 = E_1 I_1$$

and we see that the primary and secondary volt-amperes are equal. This product is usually specified as a maximum allowable value on power transformers. If the load has a phase angle θ ,

$$Z_L = |Z_L| \angle \theta$$

then E_2 leads I_2 by an angle θ . Moreover, the input impedance at the terminals of L_1 is Z_L/a^2 , and thus E_1 also lead I_1 by the same angle θ . If we let the voltage and current represent rms values, then multiplication of each side of Eq. (16-27) by $\cos \theta$ indicates once more that all the power delivered to the primary terminals reaches the load; none is absorbed by or delivered to the ideal transformer.

The characteristics of the ideal transformer which we have obtained have all been determined by frequency-domain analysis. They are certainly true in the sinusoidal steady state, but we have no reason to believe that they are correct for the complete response. Actually, they are applicable in general, and the demonstration that this statement is true is much simpler than the frequency-domain analysis we have just completed. Our analysis, however, has served to point out the exact nature of approximations which must be made on a more exact model of an actual transformer in order to obtain an ideal transformer. For example, we have seen that the reactance of the secondary winding must be much greater in magnitude than the impedance of any load which is connected to the secondary. Some feeling for those operating conditions under which a transformer ceases to behave as an ideal transformer is thus achieved.

Returning to the circuit shown in Fig. 16-13 and the two equations, (16-18) and (16-19), describing it, we may solve the second equation for di_2/dt and substitute into the first equation,

$$e_1 = L_1 \frac{di_1}{dt} + \frac{M}{L_2} e_2 - \frac{M^2}{L_2} \frac{di_1}{dt}$$

However, for unity coupling, $M^2 = L_1 L_2$, and thus

$$e_1 = \frac{M}{L_2} e_2 = \sqrt{\frac{L_1}{L_2}} e_2 = \frac{1}{a} e_2$$

The relationship between primary and secondary voltage is thus found to apply to the complete time-domain response.

An expression relating primary and secondary current is most quickly obtained by dividing Eq. (16-18) throughout by L_1 ,

$$\frac{e_1}{L_1} = \frac{di_1}{dt} + \frac{M}{L_1} \frac{di_2}{dt} = \frac{di_1}{dt} + a \frac{di_2}{dt}$$

and then invoking one of the hypotheses underlying the ideal transformer: L_1

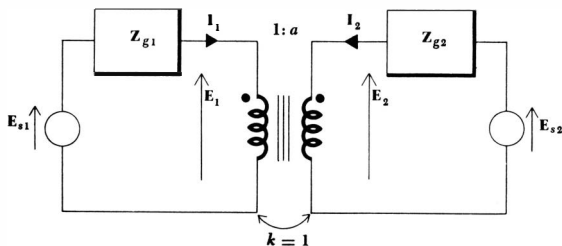

Fig. 16-17 The networks connected to the primary and secondary terminals of an ideal transformer are represented by their Thévenin equivalents.

must be infinite. If we assume that e_1 is not infinite, then

$$\frac{di_1}{dt} = -a \frac{di_2}{dt}$$

Integrating,

$$i_1 = -ai_2 + A$$

where A is a constant of integration which does not vary with time. Thus, if we neglect any direct currents in the two windings and fix our attention only on the time-varying portion of the response,

$$i_1 = -ai_2$$

The minus sign arises, of course, from the placement of the dots and selection of the current directions in Fig. 16-13.

The same current and voltage relationships are obtained in the time domain as were obtained previously in the frequency domain, provided that d-c components are ignored. The time-domain results are more general, but they have been obtained by a less informative process.

The characteristics of the ideal transformer which we have established may be utilized to simplify circuits in which ideal transformers appear. Let us assume, for purposes of illustration, that everything to the left of the primary terminals has been replaced by its Thévenin equivalent, as has the network to the right of the secondary terminals. We thus consider the circuit shown in Fig. 16-17. Excitation at any complex frequency s is assumed.

Thévenin's or Norton's theorems may now be used to achieve an equivalent circuit which does not contain a transformer. For example, let us determine the Thevenin equivalent of the network to the left of the secondary terminals. Open-circuiting the secondary, $I_2 = 0$ and therefore $I_1 = 0$ (remember L_1 is infinite). No voltage appears across Z_{g1} , and thus $E_1 = E_{s1}$ and $E_{2oc} = aE_{s1}$. The Thevenin impedance is obtained by killing E_{s1} and utilizing the square of the turns ratio, being careful to use the reciprocal turns ratio since we are looking in at the secondary terminals. Thus, $Z_{th2} = Z_{g1}a^2$. As a check on our equivalent, let us also determine the short-circuit secondary current I_{2sc} . With the secondary short-circuited, the primary generator faces an impedance of Z_{g1} and, therefore, $I_1 = E_{s1}/Z_{g1}$. Thus, $I_{2sc} = -E_{s1}/aZ_{g1}$. The ratio of the open-circuit voltage to the short-circuit current is $-a^2Z_{g1}$, as it should be. The Thévenin and Norton equivalents of the transformer and the primary circuit are shown in the circuits of Fig. 16-18*a* and *b*.

Each primary voltage may therefore be multiplied by the turns ratio, each primary current divided by the turns ratio, and each primary impedance multiplied by the square of the turns ratio, these modified voltages, currents, and impedances replacing the given voltages, currents, and impedances plus the transformer. If either dot is interchanged, the equivalent may be obtained by using the negative of the turns ratio.

A similar analysis of the transformer and the secondary network shows that everything to the right of the primary terminals may be replaced by an identi-

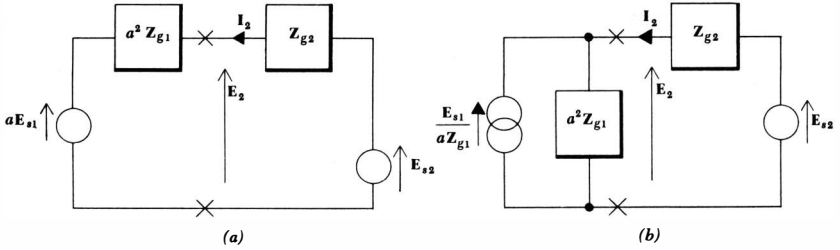

Fig. 16-18 (a) The Thévenin equivalent and (b) the Norton equivalent of the network to the left of the secondary terminals in Fig. 16-17 are used to simplify that circuit.

cal network without the transformer, each voltage being divided by a , each current being multiplied by a , and each impedance being divided by a^2 . A reversal of either winding corresponds to the use of a turns ratio of $-a$.

As a simple example of this application of equivalent circuits, consider the circuit given in Fig. 16-19. Let $a = 10$. The input impedance is $10,000/100$, or 100 ohms. Thus $I_1 = 0.25$ amp, $E_1 = 25$ volts, and the source delivers 12.5 watts, of which 6.25 watts is dissipated in the internal resistance of the source and 6.25 watts is delivered to the load. This is the condition for maximum power transfer to the load. If the secondary circuit and the ideal transformer are removed by the use of the Thévenin equivalent, the simplified circuit of Fig. 16-20a is obtained. The primary current and voltage are now immediately evident. If, instead, the network to the left of the secondary terminals is replaced by its Thévenin equivalent, the simpler circuit of Fig. 16-20b is obtained. The presence of the minus sign on the equivalent source should be verified. The corresponding Norton equivalents may also be obtained easily.

Drill Problems

16-13 The primary voltage of an ideal power distribution transformer is 2300 volts (rms), the turns ratio is 0.1, and a 10-kw 0.8 power factor lagging load is connected to the secondary. Find the rms magnitude of the: (a) secondary current; (b) primary current; (c) primary current if the load draws the same power, but at a power factor of 0.2 lagging.

Ans. 21.7 amp; 54.4 amp; 5.44 amp

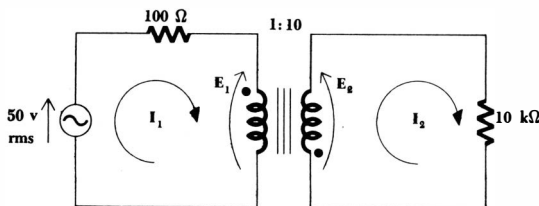

Fig. 16-19 A simple circuit in which a resistive load is matched to the source impedance by means of an ideal transformer.

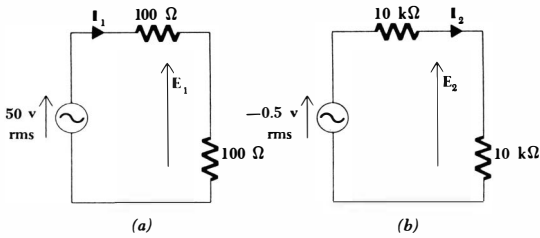

Fig. 16-20 The circuit of Fig 16-19 is simplified by replacing (a) the transformer and secondary circuit by its Thévenin equivalent and (b) the transformer and primary circuit by its Thévenin equivalent.

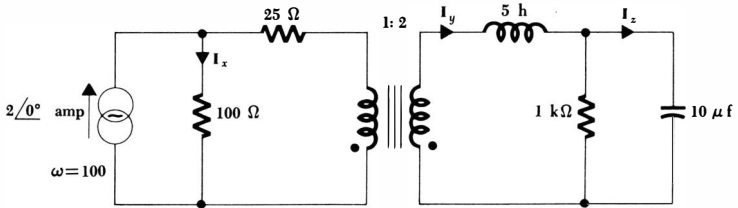

Fig. 16-21 See Drill Prob. 16-14.

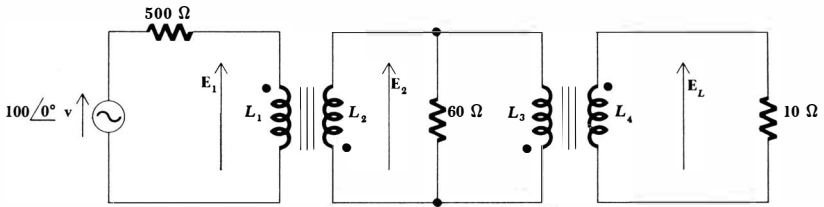

Fig. 16-22 See Drill Prob. 16-15.

16-14 In the circuit shown in Fig. 16-21, find: (a) I_x ; (b) I_y ; (c) I_z .

Ans. $0.283/45^\circ$ amp; $0.4/0^\circ$ amp; $1.2/0^\circ$ amp

16-15 The coils in the circuit shown in Fig. 16-22, identified as L_1 , L_2 , L_3 , and L_4 , have 10,000, 800, 1500, and 500 turns, respectively. Find: (a) E_1 ; (b) E_2 ; (c) E_L .

Ans. $91.8/0^\circ$ volts; $7.35/180^\circ$ volts; $2.45/0^\circ$ volts

Problems

- 1 The physical construction of two pairs of mutually coupled coils is shown in Fig. 16-23a and b. Show two different possible locations for the dots in each pair of coils.
- 2 In the network shown in Fig. 16-24a, the switch is closed at $t = 0$. Find and sketch $i_1(t)$ and $e_2(t)$.
- 3 Find e_{CD} , e_{AD} , and e_{AC} for the network shown in Fig. 16-24b.
- 4 Write mesh equations in the frequency domain for the circuit shown in Fig. 16-25.
- 5 Show that the maximum voltage-gain magnitude of the circuit shown in Fig. 16-5 is 7.20 and occurs at $\omega = 4.59$.

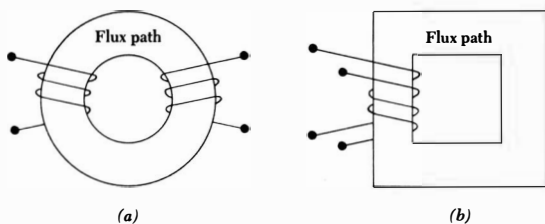

Fig. 16-23 See Prob. 1.

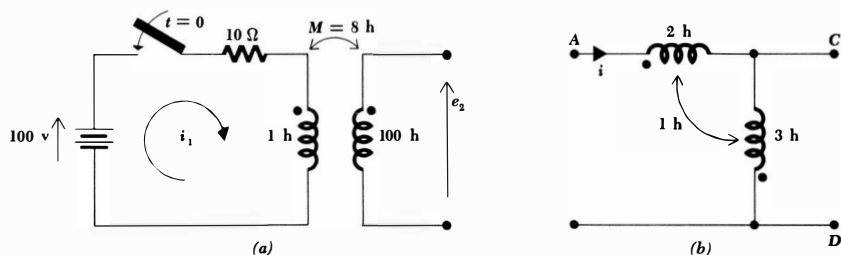
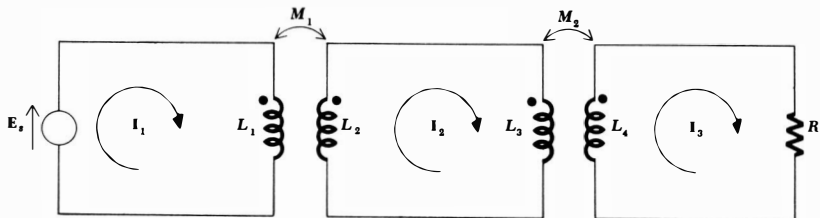

Fig. 16-24 (a) See Prob. 2. (b) See Prob. 3.

Fig. 16-25 See Prob. 4.



- 6 Apply an ideal current source I_s in parallel with the 400-ohm resistor in the circuit of Fig. 16-5, and also replace the $10\angle 0^\circ$ volt ideal voltage source with a short circuit. Let the current in the short circuit be denoted as I_1 .
 (a) Determine $I_1(j\omega)$ if $\omega = 10$ and $I_s = 10\angle 0^\circ$ amp. (b) Find the transfer function I_1/I_s as a function of s and locate all poles and zeros on the s plane. (c) Describe the magnitude of I_1/I_s as a function of ω .
- 7 By finding the ratio of the source voltage to the source current, determine the equivalent inductance seen by E_s in the circuit shown in: (a) Fig. 16-26a, two inductors connected series aiding; (b) Fig. 16-26a, with the dot on L_2 shifted to the other end of the coil, two inductors connected series opposing; (c) Fig. 16-26b, two inductors connected parallel aiding; (d) Fig. 16-26b, with the dot on L_2 shifted to the other end of the coil, two inductors connected parallel opposing; (e) Fig. 16-26c, the input inductance of a short-circuited transformer; (f) Fig. 16-26c, with the dot on L_2 shifted to the other end of the coil, the input inductance of a short-circuited transformer.
- 8 Write a complete set of loop or mesh equations in the frequency domain for the circuit shown in Fig. 16-27a.
- 9 Find $Z(s)$ for the network shown in Fig. 16-27b. Make an accompanying pole-zero plot.

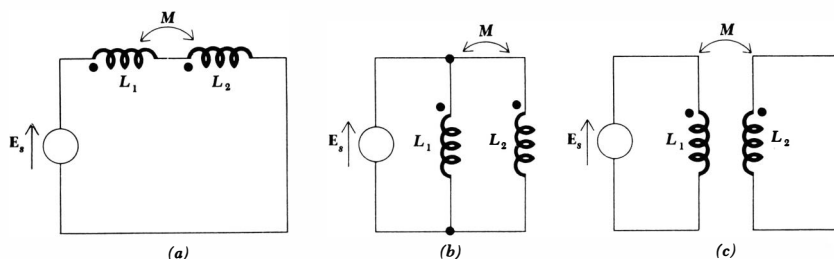
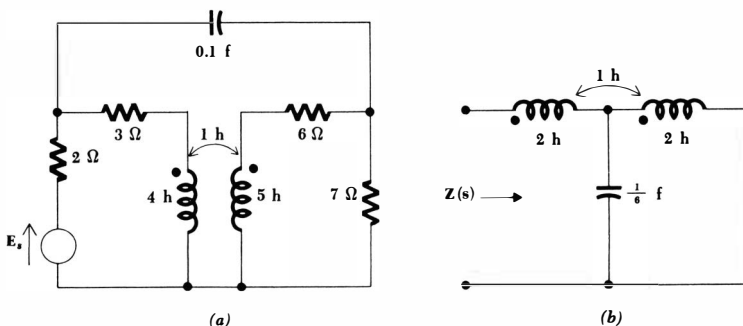

Fig. 16-26 See Prob. 7.

Fig. 16-27 (a) See Prob. 8. (b) See Prob. 9.



512 Special Topics

- 10 Obtain a set of time-domain equations which describe the response of the circuit shown in Fig. 16-28.
- 11 By extending the results of Prob. 7, prepare a table which gives the equivalent inductance of two coils connected series aiding, series opposing, parallel aiding, and parallel opposing: (a) for a general value of k ; (b) for very small values of k ; (c) for values of k which are very nearly unity.
- 12 Show how the mutual inductance and the coefficient of coupling may be determined experimentally by measuring the equivalent series-aiding and series-opposing inductances. For what range of k would this method be useful?
- 13 For the circuit shown in Fig. 16-29, which contains a simple equivalent circuit for a vacuum tube utilizing a dependent voltage source, find and sketch $i(t)$ and $i_L(t)$ for $t < 0$ and $t > 0$. Specify all asymptotic values and time constants.
- 14 Two coupled coils are inside a sealed box, and the ends are brought out to terminals $A, B, C,$ and D . The following values of inductance are determined experimentally:

$$L_{AB} = 25 \text{ mh with } C \text{ and } D \text{ open}$$

$$L_{AC} = 51 \text{ mh with } B \text{ connected to } D$$

$$L_{AD} = 19 \text{ mh with } B \text{ connected to } C$$

No connection is made in any part below unless it is explicitly stated. Find: (a) M ; (b) L_{CD} ; (c) L_{BC} with A connected to D ; (d) k ; (e) the location of the second dot if A is dotted; (f) \mathbf{E}_{CD} if $\mathbf{E}_{AB} = 100\angle 0^\circ$ volts and $\omega = 500$; (g) \mathbf{E}_{AB} and \mathbf{E}_{CD} if $\mathbf{I}_{in B} = 2.5\angle 0^\circ$ amp and $\omega = 500$; (h) \mathbf{E}_{CD} if B is connected to C , $\mathbf{I}_{in A} = 4\angle 0^\circ$ amp, $\omega = 500$; (i) \mathbf{E}_{BC} if $\mathbf{E}_{DA} = 10\angle 0^\circ$ volts, $\omega = 500$.

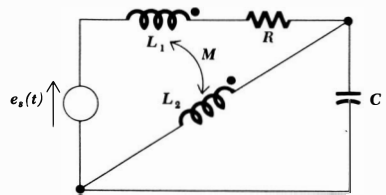
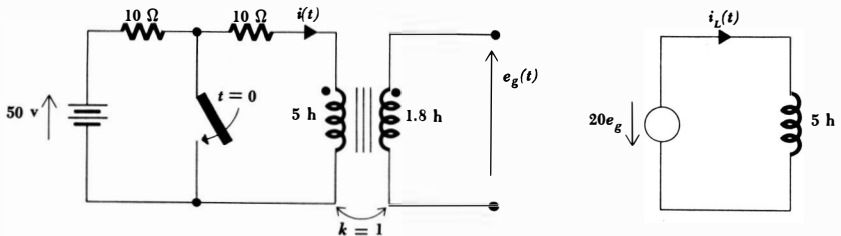

Fig. 16-28 See Prob. 10.

Fig. 16-29 See Prob. 13.



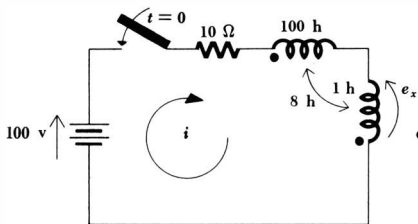

Fig. 16-30 See Prob. 15.

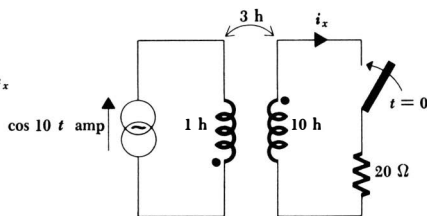
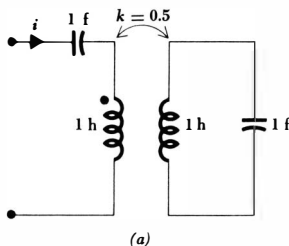
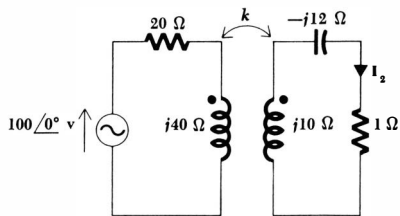

Fig. 16-31 See Prob. 17.



(a)



(b)

Fig. 16-32 (a) See Prob. 18. (b) See Prob. 19.

- 15 In the circuit of Fig. 16-30, find and sketch $i(t)$ and $e_x(t)$ on the same time axis if the switch is closed at $t = 0$.
- 16 Two coils are connected in parallel aiding. Find the equivalent inductance if: (a) $L_1 = 10$ henrys, $L_2 = 12.1$ henrys, $k = 0.999$; (b) $L_1 = 10$ henrys, $L_2 = 10$ henrys, $k = 0.999$; (c) $L_1 = 10$ henrys, $L_2 = 10.201$ henrys, $k = 0.999$.
- 17 The switch in the circuit of Fig. 16-31 is closed at $t = 0$. Find $i_x(t)$ for $t > 0$.
- ▶18 A voltage source $e_s(t) = f(t)u(t)$ is connected to the two input terminals of the network shown in Fig. 16-32a. Find the natural portion of the response $i(t)$.
- 19 With reference to the circuit shown in Fig. 16-32b, what value of k will cause $|I_2|$ to be a maximum, and what is this maximum value?
- ▶20 In the air-core transformer circuit shown in Fig. 16-33a: (a) let $k = 0$ and determine the resonant frequency of the impedance presented to the source; (b) let $k = 0.316 = \sqrt{0.1}$ and determine at what frequency or frequencies the impedance presented to the source is series resonant.
- 21 In the circuit shown in Fig. 16-33b, the power generated by the 110-volt source and the power delivered to the 1000-ohm load are to be found. All three transformers are ideal.
- ▶22 In the circuit of Fig. 16-34a, the power delivered to the 5-ohm resistor is known to be 20 watts. What power is delivered to R_1 ?
- 23 Determine the value of the turns ratio a in the circuit of Fig. 16-34b which will result in a maximum power delivered to: (a) the 600-ohm secondary load; (b) the 600-ohm resistor across the primary.

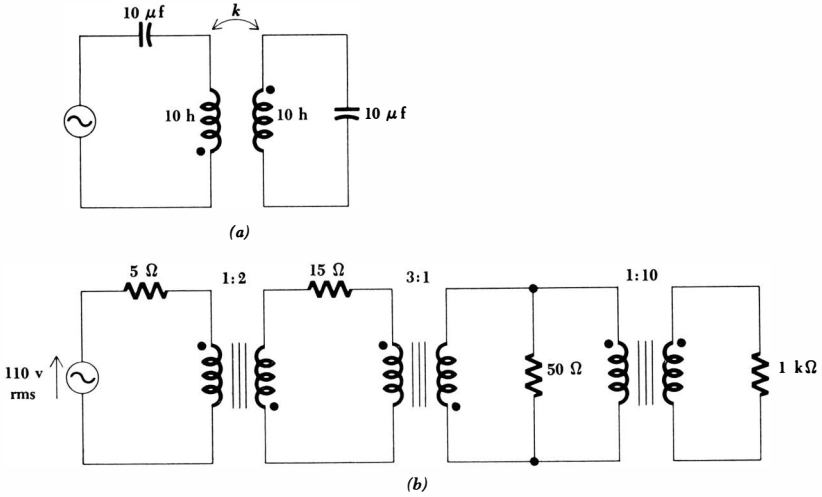

Fig. 16-33 (a) See Prob. 20. (b) See Prob. 21.

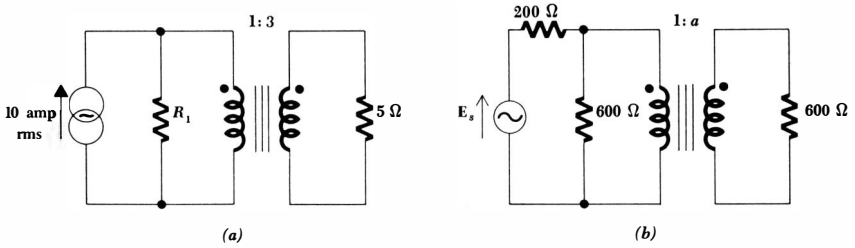

Fig. 16-34 (a) See Prob. 22. (b) See Prob. 23.

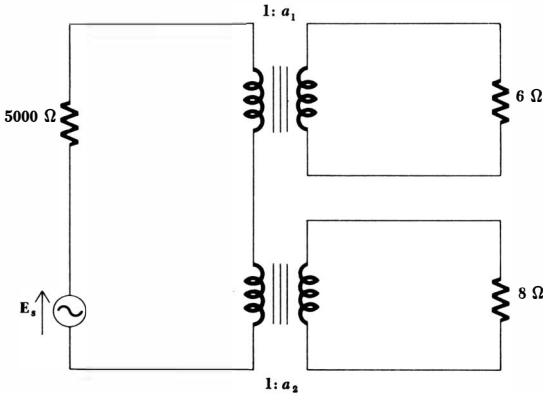

Fig. 16-35 See Prob. 24.

515 **Magnetically Coupled Circuits**

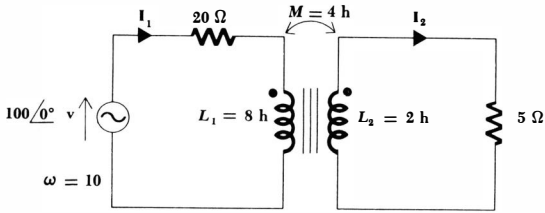

Fig. 16-36 See Prob. 26.

- ◆24 A 6-ohm loudspeaker and an 8-ohm loudspeaker are to be driven by the same source. In order to provide maximum power transfer, the resistance presented to the source must be 5000 ohms. It is desired to furnish 6 watts to the 6-ohm speaker and 2 watts to the 8-ohm speaker. A suitable circuit is shown in Fig. 16-35. Find a_1 , a_2 , and E_s (rms).
- 25 The current rating of a power transformer is often given by stating the number of kilovolt-amperes it can handle. A 230/115 volt 10-kva transformer supplies 8 kw to a 115-volt lighting load. How many kilowatts can be delivered to a 115-volt induction motor operating at 0.707 power factor (lagging) in parallel with the lighting load without overloading the transformer?
- ◆26 The transformer used in the circuit of Fig. 16-36 is not ideal. (a) Find I_1 and I_2 . (b) In order to determine the magnitude of the error which will result if the transformer is treated as if it were ideal, let L_1 and L_2 both become infinite while holding their ratio constant, and find I_1 and I_2 for this simplified circuit. (c) Compare the two sets of answers and explain the agreement or lack of agreement obtained.

Chapter 17 Two-port Networks

17-1 INTRODUCTION

In defining and using mutual inductance in the previous chapter, we were forced to consider a phenomenon associated with two pairs of terminals. A general network having two pairs of terminals, one perhaps labeled the “input terminals” and the other the “output terminals,” is a very important building block in electronic systems, communication systems, automatic control systems, transmission and distribution systems, or other systems in which an electrical signal or electrical energy enters the input terminals, is acted upon by the network, and leaves via the output terminals. The output terminal pair may very well connect with the input terminal pair of another network. A pair of terminals at which a signal may enter or leave a network is called a *port*, and a network having only one such pair of terminals is called a *one-port network*, or simply a *one port*. When more than one pair of terminals is present, the network is known as a *multiport network*. A one-port network is shown in Fig. 17-1a, and the two-port network to which this chapter is principally devoted is shown in Fig. 17-1b. We shall assume that sources and loads are connected directly across the two terminals of a port; for example, we should not expect any device to be connected between terminals *a* and *c* of the two-port network in Fig. 17-1b.

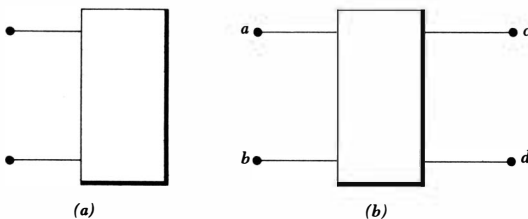

Fig. 17-1 (a) A one-port network. (b) A two-port network.

If such a circuit must be analyzed, general mesh or nodal equations should usually be written.

The special methods of analysis which are developed for two-port networks, or simply two ports, emphasize the current and voltage relationships at the terminals of the networks and suppress the specific nature of the currents and voltages within the networks. Our introductory study should serve to acquaint us with a number of important parameters and their use in simplifying and systematizing two-port network analysis.

17-2 MINORS AND COFACTORS

Some of the introductory study of two-port networks is accomplished more readily by using an abbreviated nomenclature for determinants. The symbol Δ has already been introduced for a determinant in Chap. 3, as well as the use of a subscript to identify the nature of the elements of the determinant. Thus, if we write a set of mesh equations, the coefficient of each current will be an impedance $Z_{ij}(s)$, and the circuit determinant, or determinant of the coefficients, is

$$\Delta_Z = \begin{vmatrix} Z_{11} & Z_{12} & Z_{13} & \cdots & Z_{1N} \\ Z_{21} & Z_{22} & Z_{23} & \cdots & Z_{2N} \\ Z_{31} & Z_{32} & Z_{33} & \cdots & Z_{3N} \\ \cdots & \cdots & \cdots & \cdots & \cdots \\ Z_{N1} & Z_{N2} & Z_{N3} & \cdots & Z_{NN} \end{vmatrix} \quad (17-1)$$

where N meshes have been assumed. A comparison of this determinant with those written in Chap. 3 shows that we are now allowing each mutual impedance to carry its own sign. Thus, if a 10-ohm resistor is the only element in common with meshes 1 and 2, then Z_{12} may be either +10 or -10, depending on the selection of mesh currents. The same convention will apply to the mutual-admittance terms in Δ_Y .

Let us now review briefly the nomenclature introduced in Chap. 3. There are N columns in the determinant Δ_Z , and each column contains N elements in a vertical line; the columns are numbered from left to right. This determinant must also have N rows, each row also containing N elements, but in a horizontal line. The rows are numbered from top to bottom. Thus, the element Z_{32} is located in the third row and the second column; the order of the subscripts is invariably "row column."

A *minor* of a determinant, as defined earlier, is obtained by removing or striking out one row and one column; the row and column removed are indicated by a double subscript, in the order row column. Thus

$$\Delta_{12} = \begin{vmatrix} Z_{21} & Z_{23} & Z_{24} & \cdots & Z_{2N} \\ Z_{31} & Z_{33} & Z_{34} & \cdots & Z_{3N} \\ Z_{41} & Z_{43} & Z_{44} & \cdots & Z_{4N} \\ \cdots & \cdots & \cdots & \cdots & \cdots \\ Z_{N1} & Z_{N3} & Z_{N4} & \cdots & Z_{NN} \end{vmatrix}$$

A subscript indicating the type of element of which the minor is composed is usually superfluous, since the minor generally appears in conjunction with the determinant itself in the equations which interest us.

The *cofactor* C_{ij} of a determinant is defined very simply in terms of the corresponding minor:

$$C_{ij} = (-1)^{i+j}\Delta_{ij} \quad (17-2)$$

Thus

$$C_{11} = \Delta_{11}$$

but $C_{12} = -\Delta_{12}$

The familiar expansion of a determinant along a row or column is now easily written in terms of cofactors. The expansion of Δ_Z along the first column is therefore

$$\Delta_Z = Z_{11}C_{11} + Z_{21}C_{21} + Z_{31}C_{31} + \cdots + Z_{N1}C_{N1}$$

while the expansion along the i th row would be expressed as

$$\Delta_Z = Z_{i1}C_{i1} + Z_{i2}C_{i2} + Z_{i3}C_{i3} + \cdots + Z_{iN}C_{iN}$$

As an example, let us consider this third-order determinant:

$$\Delta = \begin{vmatrix} 4 & -1 & -2 \\ -1 & 6 & -3 \\ -2 & -3 & 10 \end{vmatrix}$$

We find

$$\Delta_{11} = \begin{vmatrix} 6 & -3 \\ -3 & 10 \end{vmatrix} = 51 \quad \Delta_{12} = \begin{vmatrix} -1 & -3 \\ -2 & 10 \end{vmatrix} = -16$$

and $C_{11} = 51 \quad C_{12} = 16$

Drill Problems

17-1 Given the determinant

$$\Delta = \begin{vmatrix} 1 & j2 & -2 \\ j2 & 3 & j3 \\ -2 & 1 & 5 \end{vmatrix}$$

find: (a) Δ_{11} ; (b) C_{13} ; (c) C_{31} .

Ans. $15 - j3$; $6 + j2$; 0

17-2 For the circuit shown in Fig. 17-2, show that

$$(a) I_1 = E_1 \frac{\Delta_{11}}{\Delta_Z} \quad (b) I_2 = -E_1 \frac{\Delta_{12}}{\Delta_Z} \quad (c) I_3 = E_1 \frac{\Delta_{13}}{\Delta_Z}$$

Ans. Proof

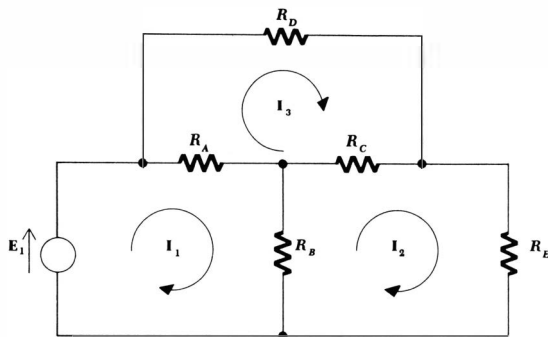

Fig. 17-2 See Drill Prob. 17-2.

17-3 ONE-PORT NETWORKS

The use of minor notation enables the input or driving-point impedance at the terminals of a *one-port* network to be expressed very concisely. The result is also applicable to a *two-port* network if one of the two ports is terminated in a passive impedance.

Let us suppose that the one-port network shown in Fig. 17-3a is composed entirely of *passive* elements; linearity is also assumed. An ideal voltage source E_1 is connected to the port, and the source current is identified as the current in mesh 1. By the familiar procedure, then,

$$I_1 = \frac{\begin{vmatrix} E_1 & Z_{12} & Z_{13} & \cdots & Z_{1N} \\ 0 & Z_{22} & Z_{23} & \cdots & Z_{2N} \\ 0 & Z_{32} & Z_{33} & \cdots & Z_{3N} \\ \dots & \dots & \dots & \dots & \dots \\ 0 & Z_{N2} & Z_{N3} & \cdots & Z_{NN} \end{vmatrix}}{\begin{vmatrix} Z_{11} & Z_{12} & Z_{13} & \cdots & Z_{1N} \\ Z_{21} & Z_{22} & Z_{23} & \cdots & Z_{2N} \\ Z_{31} & Z_{32} & Z_{33} & \cdots & Z_{3N} \\ \dots & \dots & \dots & \dots & \dots \\ Z_{N1} & Z_{N2} & Z_{N3} & \cdots & Z_{NN} \end{vmatrix}}$$

or, more concisely,

$$I_1 = \frac{E_1 \Delta_{11}}{\Delta_Z}$$

Thus,

$$Z_{in} = \frac{E_1}{I_1}$$

and $Z_{in} = \frac{\Delta_Z}{\Delta_{11}}$ (17-3)

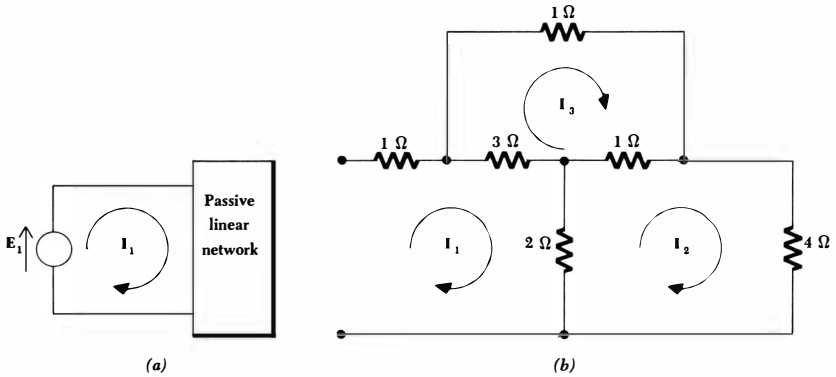

Fig. 17-3 (a) An ideal voltage source E_1 is connected to the single port of a one-port network in order to find the input impedance Z_{in} . (b) A one port used as an example.

For the one-port resistive network shown in Fig. 17-3b,

$$\Delta_Z = \begin{vmatrix} 6 & -2 & -3 \\ -2 & 7 & -1 \\ -3 & -1 & 5 \end{vmatrix} = 109$$

and $\Delta_{11} = \begin{vmatrix} 7 & -1 \\ -1 & 5 \end{vmatrix} = 34$

Thus,

$$Z_{in} = \frac{109}{34}$$

Drill Problems

17-3 If the terminal pair at the left of the network of Fig. 17-3b is short-circuited, find the impedance presented to a voltage source inserted in series with: (a) the 4-ohm resistor; (b) the topmost 1-ohm resistor; (c) the 2-ohm resistor.

Ans. 2.87 ohms; 5.19 ohms; 3.76 ohms

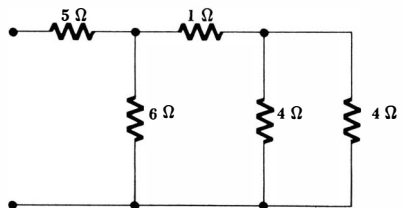

Fig. 17-4 See Drill Prob. 17-4.

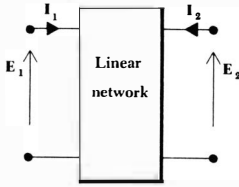

Fig. 17-5 A general two port with terminal voltages and currents specified. The two port is composed of linear elements and may contain no independent sources; dependent sources are permissible.

17-4 The input impedance of a one port may also be expressed as the reciprocal of the input admittance. In Prob. 2 it is indicated that $Y_{in} = \Delta_Y/\Delta_{11}$, where Δ_Y is the admittance determinant of the circuit. Find the input impedance of the one port shown in Fig. 17-4 by: (a) combining elements in series and parallel as necessary; (b) using Δ_Z/Δ_{11} ; (c) using Δ_{11}/Δ_Y .

Ans. 7 ohms; 7 ohms; 7 ohms

17-4 ADMITTANCE PARAMETERS

Let us now turn our attention to two-port networks. We shall assume in all that follows that the network is composed of linear elements and contains no independent sources; dependent sources are permissible, as we shall see below. Further conditions will also be placed on the network in some special cases.

We shall consider the two port as it is shown in Fig. 17-5; the voltage and current at the input terminals are E_1 and I_1 , and E_2 and I_2 are specified at the output port. The directions of I_1 and I_2 are both customarily selected as *into* the network at the upper conductors (and out at the lower conductors). Since the network is linear and contains no independent sources within it, I_1 may be considered to be the superposition of two components, one caused by E_1 and the other by E_2 . When the same argument is applied to I_2 , we may begin with the set of equations

$$I_1 = y_{11}E_1 + y_{12}E_2 \tag{17-4}$$

$$I_2 = y_{21}E_1 + y_{22}E_2 \tag{17-5}$$

where the y 's are no more than proportionality constants, or unknown coefficients, for the present. They are called the y parameters and they are defined by Eqs. (17-4) and (17-5).

The most useful and informative way to attach a physical meaning to the y parameters is through a direct inspection of Eqs. (17-4) and (17-5). Consider Eq. (17-4), for example; if we let E_2 be zero, then we see that y_{11} must be given by the ratio of I_1 to E_1 . We therefore describe y_{11} as the admittance measured at the input terminals with the output terminals *short-circuited*

($E_2 = 0$). Since there can be no question as to which terminals are short-circuited, y_{11} is best described as the *short-circuit input admittance*. Alternatively, we might describe y_{11} as the reciprocal of the input impedance measured with the output terminals short-circuited, but a description as an admittance is obviously more direct. It is not the *name* of the parameter that is important; rather it is the conditions which must be applied to Eq. (17-4) or (17-5), and hence to the network, that are most meaningful; when the conditions are determined, the parameter can be found directly from an analysis of the circuit (or by experiment on the physical circuit). Each of the y parameters may be described as a current-voltage ratio with either $E_1 = 0$ (the input terminals short-circuited) or $E_2 = 0$ (the output terminals short-circuited):

$$y_{11} = \left. \frac{I_1}{E_1} \right|_{E_2=0} \quad (17-6)$$

$$y_{12} = \left. \frac{I_1}{E_2} \right|_{E_1=0} \quad (17-7)$$

$$y_{21} = \left. \frac{I_2}{E_1} \right|_{E_2=0} \quad (17-8)$$

$$y_{22} = \left. \frac{I_2}{E_2} \right|_{E_1=0} \quad (17-9)$$

Because each parameter is an admittance which is obtained by short-circuiting either the output or input port, the y parameters are known as the *short-circuit admittance parameters*. The specific name of y_{11} is the *short-circuit input admittance*, y_{22} is the *short-circuit output admittance*, and y_{12} and y_{21} are the *short-circuit transfer admittances*.

Consider the resistive two port shown in Fig. 17-6a. The values of the parameters may be easily established by applying Eqs. (17-6) to (17-9), which we obtained directly from the defining equations (17-4) and (17-5). To determine y_{11} , we short-circuit the output and find the ratio of I_1 to E_1 . This may be done by letting $E_1 = 1$ volt, for then $y_{11} = I_1$. By inspection of Fig. 17-6a, it is apparent that 1 volt applied at the input with the output short-circuited will cause an input current of $(\frac{1}{2} + \frac{1}{10})$, or 0.3 amp. Hence,

$$y_{11} = 0.3 \text{ mho}$$

In order to find y_{12} , we short-circuit the input terminals and apply 1 volt at the output terminals. The input current flows through the short circuit and is $-\frac{1}{10}$ amp. Thus

$$y_{12} = -0.1 \text{ mho}$$

By similar methods,

$$y_{21} = -0.1 \text{ mho} \quad y_{22} = 0.15 \text{ mho}$$

The describing equations for this two port in terms of the admittance parameters are, therefore,

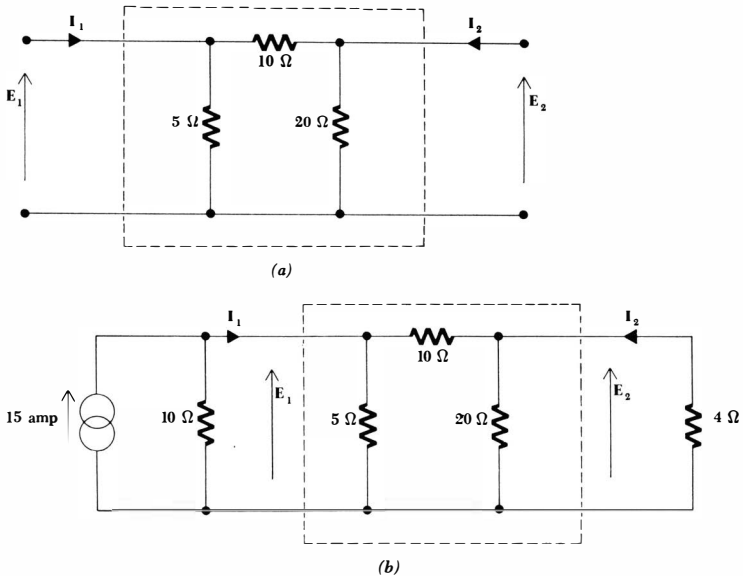

Fig. 17-6 (a) A resistive two port. (b) The resistive two port is terminated with specific networks at both ports.

$$I_1 = 0.3E_1 - 0.1E_2 \quad (17-10)$$

$$I_2 = -0.1E_1 + 0.15E_2 \quad (17-11)$$

In order to see what use might be made of such a system of equations, let us now terminate each port with some specific network. As a simple example, shown in Fig. 17-6b, let us connect a general current source to the input port and a resistive load to the output port. A relationship must now exist between E_1 and I_1 at the input port because a specific network is present. This relationship may be determined solely from this external circuit. If we apply Kirchhoff's current law (or write a single nodal equation) at the input,

$$I_1 = 15 - 0.1E_1$$

For the output, Ohm's law yields

$$I_2 = -0.25E_2$$

Substituting these expressions for I_1 and I_2 into Eqs. (17-10) and (17-11), we have

$$\begin{aligned} 15 &= 0.4E_1 - 0.1E_2 \\ 0 &= -0.1E_1 + 0.4E_2 \end{aligned}$$

from which are obtained

$$E_1 = 10 \text{ volts} \quad E_2 = 40 \text{ volts}$$

The input and output currents are also easily found, and the complete terminal characteristics of this resistive two port are then known.

The advantages of two-port analysis do not show up very strongly for such a simple example, but it should be apparent that once the y parameters are determined for a more complicated two port the performance of the two port for different terminal conditions is easily determined; it is only necessary to relate E_1 to I_1 at the input and E_2 to I_2 at the output.

In the example just concluded, y_{12} and y_{21} were both found to be -0.1 mho. It is not difficult to show that this equality is also obtained if three general impedances Z_A , Z_B , and Z_C are contained in this π network. It is somewhat more difficult to determine the specific conditions which are necessary in order that $y_{12} = y_{21}$, but the use of determinant notation is of some help. Let us see if the relationships (17-6) to (17-9) can be expressed in terms of the impedance determinant and its minors.

Since our concern is with the two port and not with the specific networks with which it is terminated, we shall let E_1 and E_2 be represented by two ideal voltage sources. Equation (17-6) is applied by letting $E_2 = 0$ (thus short-circuiting the output) and finding the input admittance. The network now, however, is simply a one port, and the input impedance of a one port was found in the previous section. We select mesh 1 to include the input terminals and let I_1 be that mesh current; we identify $(-I_2)$ as the mesh current in mesh 2 and assign the remaining mesh currents in any convenient manner.¹ Thus,

$$Z_{in}|_{E_2=0} = \frac{\Delta_Z}{\Delta_{11}}$$

and, therefore,

$$y_{11} = \frac{\Delta_{11}}{\Delta_Z} \tag{17-12}$$

Similarly,

$$y_{22} = \frac{\Delta_{22}}{\Delta_Z} \tag{17-13}$$

In order to find y_{12} , we let $E_1 = 0$, and find I_1 as a function of E_2 . We find that I_1 is given by the ratio

$$I_1 = \frac{\begin{vmatrix} 0 & Z_{12} & \cdots & Z_{1N} \\ -E_2 & Z_{22} & \cdots & Z_{2N} \\ 0 & Z_{32} & \cdots & Z_{3N} \\ \cdots & \cdots & \cdots & \cdots \\ 0 & Z_{N2} & \cdots & Z_{NN} \end{vmatrix}}{\begin{vmatrix} Z_{11} & Z_{12} & \cdots & Z_{1N} \\ Z_{21} & Z_{22} & \cdots & Z_{2N} \\ \cdots & \cdots & \cdots & \cdots \\ Z_{N1} & Z_{N2} & \cdots & Z_{NN} \end{vmatrix}}$$

¹ If the network is nonplanar and mesh analysis is inapplicable, loop currents may be selected, as discussed in the following chapter.

Thus,

$$\mathbf{I}_1 = - \frac{(-\mathbf{E}_2)\Delta_{21}}{\Delta_Z}$$

$$\text{and } y_{12} = \frac{\Delta_{21}}{\Delta_Z} \quad (17-14)$$

In a similar manner, we may show that

$$y_{21} = \frac{\Delta_{12}}{\Delta_Z} \quad (17-15)$$

The equality of y_{12} and y_{21} is thus contingent on the equality of the two minors of Δ_Z , Δ_{12} and Δ_{21} . These two minors are

$$\Delta_{21} = \begin{vmatrix} \mathbf{Z}_{12} & \mathbf{Z}_{13} & \mathbf{Z}_{14} & \cdots & \mathbf{Z}_{1N} \\ \mathbf{Z}_{32} & \mathbf{Z}_{33} & \mathbf{Z}_{34} & \cdots & \mathbf{Z}_{3N} \\ \mathbf{Z}_{42} & \mathbf{Z}_{43} & \mathbf{Z}_{44} & \cdots & \mathbf{Z}_{4N} \\ \cdots & \cdots & \cdots & \cdots & \cdots \\ \mathbf{Z}_{N2} & \mathbf{Z}_{N3} & \mathbf{Z}_{N4} & \cdots & \mathbf{Z}_{NN} \end{vmatrix} \quad \Delta_{12} = \begin{vmatrix} \mathbf{Z}_{21} & \mathbf{Z}_{23} & \mathbf{Z}_{24} & \cdots & \mathbf{Z}_{2N} \\ \mathbf{Z}_{31} & \mathbf{Z}_{33} & \mathbf{Z}_{34} & \cdots & \mathbf{Z}_{3N} \\ \mathbf{Z}_{41} & \mathbf{Z}_{43} & \mathbf{Z}_{44} & \cdots & \mathbf{Z}_{4N} \\ \cdots & \cdots & \cdots & \cdots & \cdots \\ \mathbf{Z}_{N1} & \mathbf{Z}_{N3} & \mathbf{Z}_{N4} & \cdots & \mathbf{Z}_{NN} \end{vmatrix}$$

Their equality is shown by first interchanging the rows and columns of one minor, say Δ_{21} , an operation which any college algebra book proves is valid, and then letting every mutual impedance \mathbf{Z}_{ij} be replaced by \mathbf{Z}_{ji} . Thus, we set

$$\mathbf{Z}_{12} = \mathbf{Z}_{21} \quad \mathbf{Z}_{23} = \mathbf{Z}_{32} \quad \text{etc.}$$

This equality of \mathbf{Z}_{ij} and \mathbf{Z}_{ji} is certainly obvious for the three passive elements, the resistor, capacitor, and inductor, and it is also true for mutual inductance, as we proved in the preceding chapter. However, it is not true for every type of device which we may wish to include inside a two-port network. Specifically, it is not true in general for a dependent source, and it is not true for a device which is found in some microwave circuits, the gyrator. This device, over a narrow range of radian frequencies, provides an additional phase shift of 180° for a signal passing from the output to the input over that for a signal in the forward direction, and thus $y_{12} = -y_{21}$.

Any device for which $\mathbf{Z}_{ij} = \mathbf{Z}_{ji}$ is called a *bilateral element*, and a circuit which contains only bilateral elements is called a *bilateral circuit*. We have therefore shown that an important property of a bilateral two port is

$$y_{12} = y_{21}$$

and this property is glorified by stating it as the *reciprocity theorem*:

In any passive linear bilateral network, if the single voltage source \mathbf{E}_x in branch x produces the current response \mathbf{I}_y in branch y , then the removal of the voltage source from branch x and its insertion in branch y will produce the current response \mathbf{I}_x in branch x .

A simple way of stating the theorem is to say that the interchange of an ideal voltage source and an ideal ammeter in any passive linear bilateral circuit will not change the ammeter reading.

If we had been working with the admittance determinant of the circuit and had proved that the minors Δ_{21} and Δ_{12} of the admittance determinant Δ_Y were equal, then we should have obtained the reciprocity theorem in its dual form:

In any passive linear bilateral network, if the single current source I_x between nodes x and x' produces the voltage response E_y between nodes y and y' , then the removal of the current source from nodes x and x' and its insertion between nodes y and y' will produce the voltage response E_y between nodes x and x' .

In other words, the interchange of an ideal current source and an ideal voltmeter in any passive linear bilateral circuit will not change the voltmeter reading.

Drill Problems

17-5 By applying the interpretive expressions (17-6) to (17-9) to the network shown in Fig. 17-7a, find: (a) y_{11} ; (b) $y_{12} = y_{21}$; (c) y_{22} .

Ans. -0.25 mho; 1.25 mhos; 0.25 mho

17-6 By applying the network determinant ratios (17-12) to (17-15) to the network of Fig. 17-7b, find: (a) y_{11} ; (b) $y_{12} = y_{21}$; (c) y_{22} .

Ans. $\frac{3}{8}$ mhos; $\frac{3}{8}$ mhos; $-\frac{1}{3}$ mho

17-7 A two port has two sets of measurements made on it at a frequency of 1000 cps. When $E_1 = E_2 = 1/0^\circ$ volt, then $I_2 = 2I_1 = 2/90^\circ$ amp; but when $E_1 = -E_2 = 1/0^\circ$ volt, then $I_1 = 3/90^\circ$ amp and $I_2 = 0$. Find: (a) y_{12} ; (b) y_{21} ; (c) y_{22} .

Ans. $j1$ mho; $j1$ mho; $-j1$ mho

17-5 SOME EQUIVALENT NETWORKS

The two basic equations which determine the short-circuit admittance parameters,

$$I_1 = y_{11}E_1 + y_{12}E_2 \quad (17-16)$$

$$I_2 = y_{21}E_1 + y_{22}E_2 \quad (17-17)$$

have the form of a pair of nodal equations written for a circuit containing two nonreference nodes. There is one important difference, however, in that the circuits we are accustomed to work with are bilateral circuits in which $y_{12} = y_{21}$. In general these parameters cannot be assumed equal, and it is necessary to resort to a little trickery in order to obtain a pair of equations which will possess equal mutual coefficients. Let us add and subtract $y_{12}E_1$ (the term we would like to see present in the second equation above) on the right side of Eq. (17-17),

$$I_2 = y_{12}E_1 + y_{22}E_2 + (y_{21} - y_{12})E_1 \quad (17-18)$$

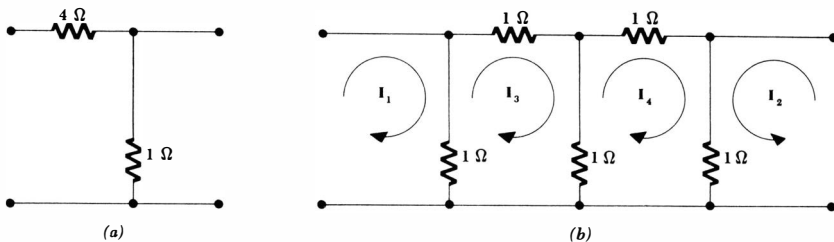

Fig. 17-7 (a) See Drill Prob. 17-5. (b) See Drill Prob. 17-6.

$$\text{or} \quad \mathbf{I}_2 - (y_{21} - y_{12})\mathbf{E}_1 = y_{12}\mathbf{E}_1 + y_{22}\mathbf{E}_2 \quad (17-19)$$

The right sides of Eqs. (17-16) and (17-19) now show the proper symmetry for a bilateral circuit; the left side of Eq. (17-19) may be interpreted as the algebraic sum of two current sources, one an independent source \mathbf{I}_2 entering node 2, and the other a dependent source $(y_{21} - y_{12})\mathbf{E}_1$ leaving node 2. This latter source is dependent since its value depends on the input voltage \mathbf{E}_1 . It is still an ideal source in that its current output is independent of all other characteristics of the network in which it is placed; it is dependent only on \mathbf{E}_1 .

Let us now “read” the equivalent network from Eqs. (17-16) and (17-19). We first establish the reference node, and then a node labeled \mathbf{E}_1 and one labeled \mathbf{E}_2 . From Eq. (17-16), we establish the current \mathbf{I}_1 flowing into node 1, we supply a mutual admittance $(-y_{12})$ between nodes 1 and 2, and we supply an admittance between node 1 and the reference node of $(y_{11} + y_{12})$. With node 2 connected to the reference node, or $\mathbf{E}_2 = 0$, the ratio of \mathbf{I}_1 to \mathbf{E}_1 is then y_{11} , as it should be. Now consider Eq. (17-19); we cause the current \mathbf{I}_2 to flow into the second node, we cause the current $(y_{21} - y_{12})\mathbf{E}_1$ to leave the node, we note that the proper admittance $(-y_{12})$ exists between the nodes, and we complete the circuit by installing the admittance $(y_{22} + y_{12})$ from node 2 to the reference node. The completed circuit is shown in Fig. 17-8a.

Another form of equivalent network is obtained by subtracting and adding $y_{21}\mathbf{E}_2$ in Eq. (17-16); this equivalent circuit is shown in Fig. 17-8b.

If the two port is bilateral, then $y_{12} = y_{21}$, and either of the equivalents reduces to a simple π network. The dependent source disappears. This equivalent of the bilateral two port is shown in Fig. 17-8c.

There are several uses to which these equivalent circuits may be put. In the first place, we have succeeded in showing that an equivalent of any complicated linear two port *exists*. It does not matter how many nodes or meshes are contained within the network; the equivalent is no more complex than the circuits of Fig. 17-8. One of these circuits may be much simpler to use than the given circuit if we are interested only in the terminal characteristics of the given network. We should also realize that transistor and vacuum-tube amplifiers must possess equivalent circuits in the form of Fig. 17-8a and b. The form shown in Fig. 17-8a is particularly suitable for a vacuum-tube amplifier, as discussed in Probs. 24 and 25 at the end of this chapter.

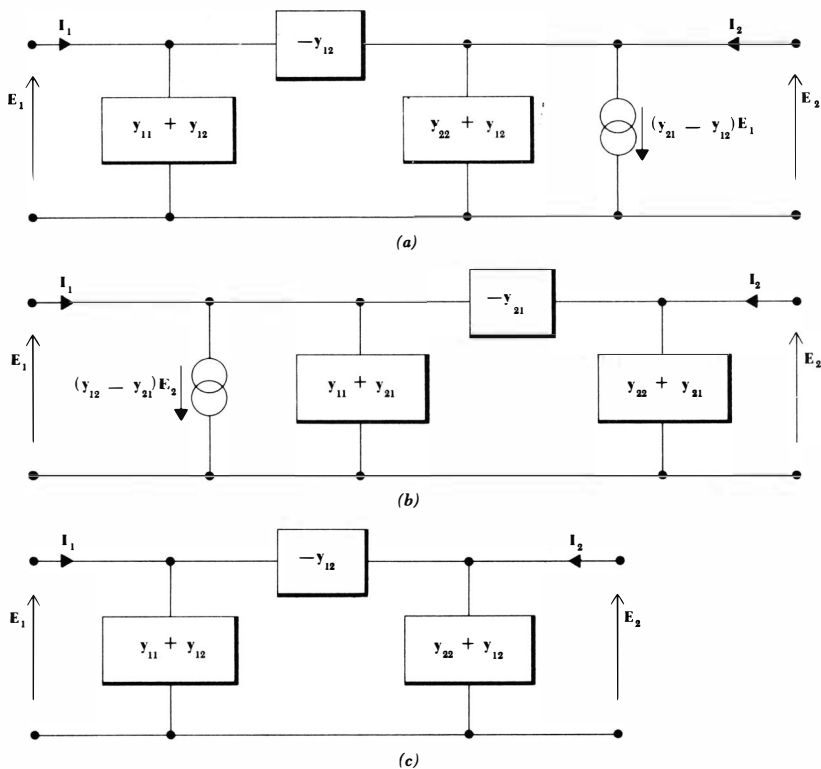

Fig. 17-8 (a) and (b) Two ports which are equivalent to any general linear two port. The dependent source in (a) depends on E_1 , and that in (b) depends on E_2 . (c) An equivalent for a bilateral network.

As an example of the use of an equivalent circuit and a dependent generator, let us consider the two port shown in Fig. 17-9. The circuit happens to be in the form of a low-frequency vacuum-tube amplifier with resistive coupling between plate and grid, but the values of the circuit elements are not in the least typical. There are two ways we might think about this circuit. If we recognize it as being in the form of the equivalent circuit shown in Fig. 17-8a, then we may immediately determine the values of the y parameters. If recognition is not immediate, then the y parameters may be determined for the two port by applying the relationships (17-6) to (17-9). We also might avoid any use of two-port analysis methods and write equations directly for the circuit as it stands. Let us compare the network with the equivalent circuit. Thus, we first obtain

$$y_{12} = -1 \text{ mho}$$

and, hence,

$$y_{11} = 4 - (-1) = 5 \text{ mhos}$$

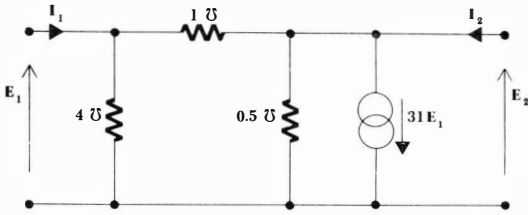

Fig. 17-9 A two-port containing a dependent source used as an example.

Then

$$y_{22} = 0.5 - (-1) = 1.5 \text{ mhos}$$

and $y_{21} = 31 + (-1) = 30 \text{ mhos}$

The following equations must then apply:

$$I_1 = 5E_1 - E_2 \tag{17-20}$$

$$I_2 = 30E_1 + 1.5E_2 \tag{17-21}$$

Now let us make use of these two equations by analyzing the performance of this two port when a current source $1/0^\circ$ amp is provided at the input and a 1.5-mho load is connected to the output. The terminating networks thus give us the following specific information relating I_1 to E_1 and I_2 to E_2 :

$$I_1 = 1$$

which is independent of E_1 , and

$$I_2 = -1.5E_2$$

Substituting into Eqs. (17-20) and (17-21), we may obtain two equations relating E_1 and E_2 :

$$1 = 5E_1 - E_2 \quad 0 = 30E_1 + 3E_2$$

Thus

$$\begin{aligned} E_1 &= \frac{1}{5} \text{ volt} & E_2 &= -\frac{2}{3} \text{ volt} \\ I_1 &= 1 \text{ amp} & I_2 &= 1 \text{ amp} \end{aligned}$$

From these data, it is easy to calculate the voltage gain

$$G_V = \frac{E_2}{E_1} = -10$$

the current gain

$$G_I = \frac{I_2}{I_1} = 1$$

and, if sinusoidal excitation is assumed, the power gain

$$G_P = \frac{P_{out}}{P_{in}} = \frac{-\frac{1}{2}E_2I_2^*}{\frac{1}{2}E_1I_1^*} = 10$$

The device might be termed either a voltage amplifier or a power amplifier, since both the voltage gain and the power gain are greater than unity. Much greater gains are possible in practical transistor and vacuum-tube amplifiers.

The input and output impedances of the amplifier are often desired in order that maximum power transfer may be achieved to or from an adjacent two port. The input impedance is the ratio of input voltage to current:

$$Z_{\text{in}} = \frac{E_1}{I_1} = \frac{1}{5} \text{ ohm}$$

This is the impedance offered to the current source when the 1.5-mho load is connected to the output. With the output short-circuited, the input impedance is necessarily $1/y_{11}$, or $\frac{1}{5}$ ohm. It should be noted that the input impedance *cannot* be determined by replacing every source by its internal impedance and then combining resistances or conductances. In the circuit given, this procedure would yield a value of $\frac{3}{5}$ ohm. The error of course comes from treating the dependent source as an independent source. If we think of the input impedance as being numerically equal to the input voltage produced by an input current of 1 amp, the application of the 1-amp source produces some input voltage E_1 , and the strength of the dependent source ($31E_1$) cannot be zero. For future reference, we should note that when we obtain the Thévenin equivalent impedance of a circuit containing a dependent source along with one or more independent sources, we must replace the independent sources by short circuits or open circuits, but a dependent source must not be killed. Of course, if the voltage or current on which the dependent source depends is zero, the dependent source will itself be inactive; occasionally a circuit may be simplified by recognizing such an occurrence.

The output impedance is just another term for the Thévenin impedance appearing in the Thévenin equivalent circuit of that portion of the network faced by the load. In our circuit, which we have assumed driven by a $1/0^\circ$ amp current source, we therefore replace this source by an open circuit, leave the dependent source alone, and seek the *input* impedance seen looking to the left

Fig. 17-10 (a) The Norton equivalent of the network (Fig. 17-9) to the left of the output terminals, with $I_1 = 1/0^\circ$ amp. (b) The Thévenin equivalent of the portion of the network to the right of the input terminals, if $I_2 = -1.5E_2$.

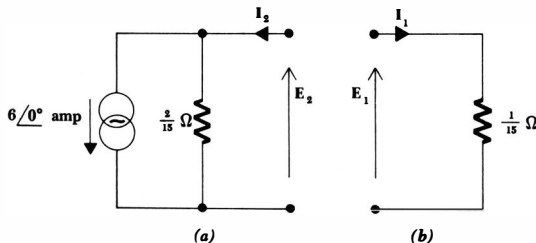

from the output terminals. This impedance may be found by several methods (none of which consists of combining all the elements in series or in parallel); let us apply 1 amp at the output terminals and determine E_2 . We place these requirements on Eqs. (17-20) and (17-21) and obtain

$$0 = 5E_1 - E_2 \quad 1 = 30E_1 + 1.5E_2$$

Solving,

$$E_2 = \frac{1}{7.5} \text{ volt}$$

and thus

$$Z_{\text{out}} = \frac{1}{7.5} \text{ ohm}$$

An alternative procedure might be to find the open-circuit output voltage and the short-circuit output current; the ratio is the Thévenin impedance or Z_{out} . With an input current $I_1 = 1$ and with the load short-circuited ($E_2 = 0$), we find

$$I_1 = 1 = 5E_1 - 0 \quad I_2 = 30E_1 + 0$$

and thus

$$I_{2sc} = 6$$

Again, with $I_1 = 1$ and with the output open-circuited ($I_2 = 0$), we have

$$1 = 5E_1 - E_2 \quad 0 = 30E_1 + 1.5E_2$$

and $E_{2oc} = -0.8$ volt

The assumed directions of E_2 and I_2 therefore result in a Thévenin or output impedance

$$Z_{\text{out}} = -\frac{E_{2oc}}{I_{2sc}} = -\frac{-0.8}{6} = \frac{1}{7.5} \text{ ohm}$$

as before.

We now have enough information to enable us to draw the Thévenin or Norton equivalent of the two port of Fig. 17-9 (driven by a $1\angle 0^\circ$ amp current source and terminated in a 1.5-mho load, although this termination is of no consequence in the equivalent circuits) as offered to the 1.5-mho load. The Thévenin and Norton equivalents offered to the current source are also readily drawn. Thus, the Norton equivalent presented to the load must contain a current source equal to the short-circuit current I_{sc2} in parallel with the output impedance; this equivalent is shown in Fig. 17-10a. The Thévenin equivalent offered to the $1\angle 0^\circ$ amp input source must consist solely of the input impedance, as drawn in Fig. 17-10b.

Drill Problems

- 17-8** A two port is described by the following parameters: $y_{11} = 0.1$ mho; $y_{12} = -0.2$ mho; $y_{21} = 5$ mhos; $y_{22} = 1$ mho. Find E_2 if: (a) $E_1 = 10\angle 0^\circ$ volts and the network is terminated in $Y_L = 0.2$ mho; (b) $I_1 = 10\angle 0^\circ$ amp and the network is terminated in $Y_L = 0.2$ mho;

(c) a source $10\angle 0^\circ$ volts in series with a 5-ohm resistor is connected to the input port and a 5-ohm resistor is connected to the output port.

Ans. -7.35 volts; -44.6 volts; -41.7 volts

17-9 For the circuit shown in Fig. 17-11, find: (a) y_{12} ; (b) y_{21} ; (c) y_{22} .

Ans. -0.5 mho; 0.75 mho; 2 mhos

17-10 Without finding the y parameters for the two port shown in Fig. 17-11, write mesh or nodal equations directly and determine: (a) the input impedance with the output open-circuited; (b) the output impedance if an ideal current source is connected to the input; (c) the output impedance if an ideal voltage source is connected to the input.

Ans. 1.333 ohms; 0.545 ohm; 0.364 ohm

17-11 The two port whose parameters are specified in Drill Prob. 17-8 is driven by an ideal sinusoidal voltage source E_s in series with a 2-ohm resistor and terminated in a resistor R_L . Find the value of R_L which will result in a maximum magnitude of: (a) the voltage gain E_2/E_s ; (b) the current gain I_2/I_1 ; (c) the power gain $(-\frac{1}{2}E_2I_2^*)/(\frac{1}{2}E_1I_1^*)$. (NOTE: Maximum power gain and maximum power output are not synonymous.)

Ans. 0 ohms; ∞ ; 0.302 ohm

17-6 IMPEDANCE PARAMETERS

The concept of two-port parameters has been introduced in terms of the short-circuit admittance parameters. There are other sets of parameters, however, and each set is associated with a particular class of networks for which its use provides the simplest analysis. We shall consider only two other types of parameters, the open-circuit impedance parameters which are the subject of this section and the hybrid parameters which are discussed in the following section.

We begin again with the general linear two port which does not contain any independent sources; the currents and voltages are assigned as before (Fig. 17-5). Now let us consider the voltage E_1 as the response produced by two current sources I_1 and I_2 . We thus write for E_1

$$E_1 = z_{11}I_1 + z_{12}I_2 \quad (17-22)$$

and for E_2

$$E_2 = z_{21}I_1 + z_{22}I_2 \quad (17-23)$$

Of course, in using this pair of equations it is not necessary that I_1 and I_2 be current sources; nor is it necessary that E_1 and E_2 be voltage sources. In general, we may have any networks terminating the two port at either end. As the equations are written, we probably think of E_1 and E_2 as given quantities, or in-

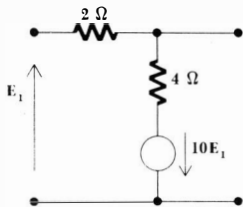

Fig. 17-11 See Drill Probs. 17-9, 17-10, and 17-12.

dependent variables, and \mathbf{I}_1 and \mathbf{I}_2 as unknowns, or dependent variables. The various ways in which two equations may be written to relate these four quantities define the different systems of parameters.

The most informative description of the z parameters, defined in Eqs. (17-22) and (17-23), is obtained by setting each of the currents equal to zero. Thus

$$z_{11} = \left. \frac{\mathbf{E}_1}{\mathbf{I}_1} \right|_{\mathbf{I}_2 = 0} \quad (17-24)$$

$$z_{12} = \left. \frac{\mathbf{E}_1}{\mathbf{I}_2} \right|_{\mathbf{I}_1 = 0} \quad (17-25)$$

$$z_{21} = \left. \frac{\mathbf{E}_2}{\mathbf{I}_1} \right|_{\mathbf{I}_2 = 0} \quad (17-26)$$

$$z_{22} = \left. \frac{\mathbf{E}_2}{\mathbf{I}_2} \right|_{\mathbf{I}_1 = 0} \quad (17-27)$$

Since zero current results from an open-circuit termination, the z parameters are known as the *open-circuit impedance parameters*. They are easily related to the short-circuit admittance parameters by solving Eqs. (17-22) and (17-23) for \mathbf{I}_1 and \mathbf{I}_2 :

$$\mathbf{I}_1 = \frac{\begin{vmatrix} \mathbf{E}_1 & z_{12} \\ \mathbf{E}_2 & z_{22} \end{vmatrix}}{\begin{vmatrix} z_{11} & z_{12} \\ z_{21} & z_{22} \end{vmatrix}}$$

$$\text{or} \quad \mathbf{I}_1 = \left(\frac{z_{22}}{z_{11}z_{22} - z_{12}z_{21}} \right) \mathbf{E}_1 + \left(-\frac{z_{12}}{z_{11}z_{22} - z_{12}z_{21}} \right) \mathbf{E}_2$$

Using determinant notation, and being careful that the subscript is a lowercase z , we have

$$y_{11} = \frac{\Delta_{11}}{\Delta_z} \quad y_{12} = -\frac{\Delta_{21}}{\Delta_z}$$

and from solving for \mathbf{I}_2 ,

$$y_{21} = -\frac{\Delta_{12}}{\Delta_z} \quad y_{22} = \frac{\Delta_{22}}{\Delta_z}$$

In a similar manner, the z parameters may be expressed in terms of the admittance parameters. Transformations of this nature are possible between

Fig. 17-12 The Thévenin equivalent of a general two port, as viewed from the output terminals, expressed in terms of the open-circuit impedance parameters.

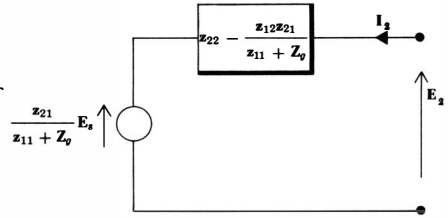

any of the various parameter systems, and quite a collection of occasionally useful formulas may be obtained. We shall not specifically consider any other transformations.²

If the two port is a bilateral network, reciprocity is present; it is easy to show that this results in the equality of z_{12} and z_{21} .

Equivalent circuits may again be obtained from an inspection of Eqs. (17-22) and (17-23); their construction is facilitated by adding and subtracting either $z_{12}I_1$ to Eq. (17-23) or $z_{21}I_2$ to Eq. (17-22). Each of these equivalent circuits contains a dependent voltage source.

Let us leave the derivation of these equivalents to the problems and first consider an example of a rather general nature. Can we construct a general Thévenin equivalent of the two port, as viewed from the output terminals?

Let us leave the derivation of these equivalents to the problems and first consider an example of a rather general nature. Can we construct a general Thévenin equivalent of the two port, as viewed from the output terminals? It is necessary first to assume a specific input circuit configuration, and we shall select an independent voltage source E_s in series with a generator impedance Z_g . Thus

$$E_s = E_1 + I_1 Z_g$$

Combining this result with Eqs. (17-22) and (17-23), we may eliminate E_1 and I_1 , and obtain

$$E_2 = \frac{z_{21}}{z_{11} + Z_g} E_s + \left(z_{22} - \frac{z_{12}z_{21}}{z_{11} + Z_g} \right) I_2$$

The Thévenin equivalent circuit may be drawn directly from this equation; it is shown in Fig. 17-12. The output impedance, expressed in terms of the z parameters, is

$$Z_{out} = z_{22} - \frac{z_{12}z_{21}}{z_{11} + Z_g}$$

If the generator impedance is zero, the simpler expression

$$Z_{out} = \frac{z_{11}z_{22} - z_{12}z_{21}}{z_{11}} = \frac{\Delta_z}{\Delta_{22}} = \frac{1}{y_{22}} \quad (Z_g = 0)$$

is obtained. For this special case, the output admittance is identical to y_{22} , as indicated by the basic relationship of Eq. (17-9).

² Except in the problems.

535 Two-port Networks

As a numerical example, let us use a set of impedance parameters which are representative of a transistor operating in what is known as the grounded-emitter configuration. We assume

$$\begin{aligned} z_{11} &= 10^3 \text{ ohms} & z_{12} &= 10 \text{ ohms} \\ z_{21} &= -10^6 \text{ ohms} & z_{22} &= 10^4 \text{ ohms} \end{aligned}$$

and we shall consider the two port as driven by an ideal sinusoidal voltage source E_1 and terminated in a 10,000-ohm resistor. The two describing equations are

$$E_1 = 10^3 I_1 + 10 I_2 \quad (17-28)$$

$$E_2 = -10^6 I_1 + 10^4 I_2 \quad (17-29)$$

and the characterizing equation of the output network is

$$E_2 = -10^4 I_2 \quad (17-30)$$

Substituting Eq. (17-30) into Eq. (17-29), we have

$$0 = -10^6 I_1 + 20,000 I_2 \quad (17-31)$$

Using Eqs. (17-31) and (17-28), we may find I_1 and I_2 in terms of E_1 . Thus

$$I_1 = \frac{1}{1500} E_1 \quad I_2 = \frac{1}{30} E_1$$

$$E_2 = -333 E_1$$

From this information, it is easy to determine the voltage gain

$$G_V = -333$$

the current gain

$$G_I = 50$$

the power gain

$$G_p = 16,700$$

and the input impedance

$$Z_{in} = 1500 \text{ ohms}$$

The output impedance cannot be determined from these data, for it is not a function of the 10,000-ohm load resistor (and all the above responses are). The Thévenin equivalent obtained previously, Fig. 17-12, however, shows that

$$Z_{out} = 20,000 \text{ ohms}$$

Drill Problems

17-12 For the circuit shown in Fig. 17-11, find: (a) z_{12} ; (b) z_{21} ; (c) z_{22} .

Ans. $\frac{1}{2} \text{ ohm}$; $\frac{1}{2} \text{ ohm}$; $-1\frac{1}{2} \text{ ohms}$

17-13 A two port is described in terms of the two equations $\mathbf{E}_1 = 9\mathbf{E}_2 - 7\mathbf{I}_2$ and $\mathbf{I}_1 = 5\mathbf{E}_2 - 4\mathbf{I}_2$. Find: (a) z_{11} ; (b) z_{12} ; (c) z_{21} .

Ans. 0.2 ohm; 0.2 ohm; 1.8 ohms

17-14 The z parameters for the equivalent circuit shown in Fig. 17-13 are $z_{11} = 3$ ohms; $z_{12} = 2$ ohms; $z_{21} = 1$ ohm; $z_{22} = 5$ ohms. Find: (a) R_1 ; (b) R_2 ; (c) R_3 .

Ans. 1 ohm; 2 ohms; 3 ohms

17-7 HYBRID PARAMETERS

The use of the hybrid parameters is well suited to transistor circuits because these parameters are among the most convenient to measure experimentally for a transistor. The difficulty in measuring, say, the open-circuit impedance parameters arises when a parameter such as z_{21} must be measured. A known sinusoidal current is easily supplied at the input terminals, but because of the exceedingly high output impedance of the transistor circuit, it is difficult to open-circuit the output terminals and yet supply the necessary d-c biasing voltages and measure the sinusoidal output voltage. A short-circuit current measurement at the output terminals is much simpler to instrument.

The hybrid parameters are defined by writing the pair of equations relating \mathbf{E}_1 , \mathbf{I}_1 , \mathbf{E}_2 , and \mathbf{I}_2 as if \mathbf{E}_1 and \mathbf{I}_2 were the independent variables:

$$\mathbf{E}_1 = h_{11}\mathbf{I}_1 + h_{12}\mathbf{E}_2 \quad (17-32)$$

$$\mathbf{I}_2 = h_{21}\mathbf{I}_1 + h_{22}\mathbf{E}_2 \quad (17-33)$$

The nature of the parameters is made clear by first setting $\mathbf{E}_2 = 0$,

$$h_{11} = \left. \frac{\mathbf{E}_1}{\mathbf{I}_1} \right|_{\mathbf{E}_2=0} = \text{short-circuit input impedance}$$

$$\text{and } h_{21} = \left. \frac{\mathbf{I}_2}{\mathbf{I}_1} \right|_{\mathbf{E}_2=0} = \text{short-circuit current gain}$$

and then letting $\mathbf{I}_1 = 0$,

$$h_{12} = \left. \frac{\mathbf{E}_1}{\mathbf{E}_2} \right|_{\mathbf{I}_1=0} = \text{open-circuit reverse voltage gain}$$

$$\text{and } h_{22} = \left. \frac{\mathbf{I}_2}{\mathbf{E}_2} \right|_{\mathbf{I}_1=0} = \text{open-circuit output admittance}$$

In view of the fact that the parameters represent an impedance, an admittance, a voltage gain, and a current gain, it is understandable that they are called the "hybrid" parameters.

In order to illustrate the ease with which these parameters may be evaluated, consider the bilateral resistive circuit drawn in Fig. 17-14a. With the output

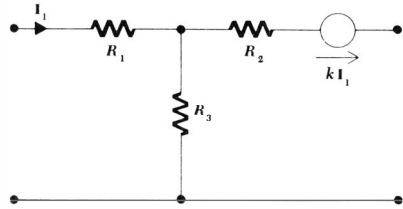

Fig. 17-13 See Drill Prob. 17-14.

short-circuited ($E_2 = 0$), the application of a 1-amp source at the input ($I_1 = 1$ amp) produces an input voltage of 3.4 volts ($E_1 = 3.4$ volts); hence, $h_{11} = 3.4$ ohms. Under these same conditions, the output current is easily obtained by current division, $I_2 = -0.4$ amp; thus, $h_{21} = -0.4$. The remaining two parameters are obtained with the input open-circuited ($I_1 = 0$). Let us apply a voltage at the output terminals of 1 volt ($E_2 = 1$ volt). The response at the input terminals is 0.4 volt ($E_1 = 0.4$ volt), and thus $h_{12} = 0.4$. The current delivered by this source at the output terminals is 0.1 amp ($I_2 = 0.1$ amp), and therefore $h_{22} = 0.1$ mho. It is a consequence of the reciprocity theorem that $h_{12} = -h_{21}$ for a bilateral network.

Now let us spice up this network slightly by including a dependent voltage source as shown in Fig. 17-14*b*. Short-circuiting the output terminals and applying $I_1 = 1$ amp, we find that we have a simple circuit, but one which is difficult to solve “by inspection.” The dependent voltage source has an amplitude of 100 volts, and superposition enables us to find I_2 ,

$$I_2 = \frac{-4}{4 + 6} + \frac{100}{4 + 6} = 9.6 \text{ amp}$$

Thus, $h_{21} = 9.6$. Knowing I_1 and I_2 , the voltage across the 4-ohm resistor is calculated as 42.4 volts, and thus $E_1 = 43.4$ volts; $h_{11} = 43.4$ ohms. We next open-circuit the input terminals ($I_1 = 0$), thus killing the dependent source. Hence, h_{12} and h_{22} are unchanged: $h_{12} = 0.4$, $h_{22} = 0.1$ mho.

If we now install an input network which consists of a 0.1-volt sinusoidal

Fig. 17-14 (a) A bilateral network for which the h parameters are found; $h_{12} = -h_{21}$. (b) A dependent voltage source is added to the same two port; the network is no longer bilateral.

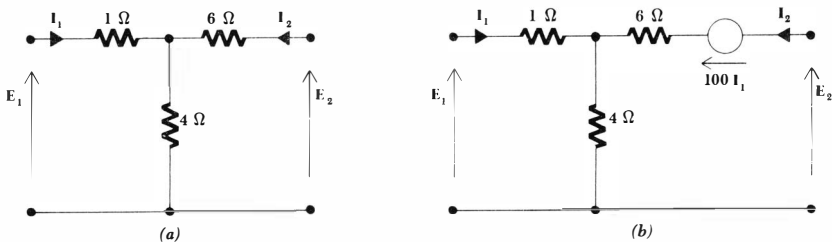

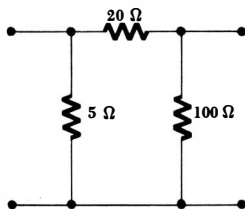

Fig. 17-15 See Drill Prob. 17-15.

source in series with a 2-ohm resistor and an output network which is simply a 10-ohm resistor, we may ask for the value of E_2 . The two-port equations are

$$E_1 = 43.4I_1 + 0.4E_2 \quad (17-34)$$

$$I_2 = 9.6I_1 + 0.1E_2 \quad (17-35)$$

and the terminating networks are described by the two relationships

$$E_1 = 0.1 - 2I_1 \quad (17-36)$$

$$E_2 = -10I_2 \quad (17-37)$$

Eliminating E_1 between Eqs. (17-34) and (17-36),

$$0.1 = 45.4I_1 + 0.4E_2$$

and eliminating I_2 between Eqs. (17-35) and (17-37),

$$0 = 9.6I_1 + 0.2E_2$$

we may readily solve for E_2 :

$$E_2 = -0.1832 \text{ volt}$$

For those who desire additional practice in the manipulation of these equations, it may be pointed out that the ratio of the power absorbed in the 10-ohm load to the power delivered by the 0.1-volt source is 8.79.

Drill Problems

17-15 For the resistive network shown in Fig. 17-15, find: (a) h_{11} ; (b) $h_{12} = -h_{21}$; (c) h_{22} .

Ans. 0.05 mho; 4 ohms; 0.2

17-16 For the grounded-emitter transistor data given in Sec. 17-6, find: (a) h_{11} ; (b) h_{21} ; (c) h_{22} .

Ans. 100; 2000 ohms; 10^{-4} mho

17-17 The hybrid parameters applicable to a certain two port are $h_{11} = 10$ ohms, $h_{12} = 0.1$, $h_{21} = 5$, $h_{22} = 0.2$ mho. A $10\angle 0^\circ$ ma current source in parallel with a 25-ohm resistor is connected to the input, and a load resistor R_L is connected to the output port. (a) What value of R_L will draw a maximum power from the network? (b) With this

539 **Two-port Networks**

value of \mathbf{R}_L connected, what is the input impedance (excluding the parallel 25-ohm resistor)? (c) What is this input impedance if $\mathbf{R}_L = 0$?

Ans. 5.38 ohms; 8.70 ohms; 10.0 ohms

Problems

- ◆1 The impedance determinant of a certain three-mesh network is

$$\Delta_Z = \begin{vmatrix} 10 & -2 & -7 \\ -2 & 10 & -3 \\ -7 & -3 & 15 \end{vmatrix}$$

- (a) A 10-volt d-c source is inserted in mesh 1, but not in any other mesh. How much power does it deliver to the network? (b) Repeat for meshes 2 and 3. (c) The 10-volt source is now inserted in mesh 1 (only) again. What current flows in mesh 2? (d) The source is inserted in mesh 2 (only). What current flows in mesh 1?
- 2 Given a general one-port network, let the upper input terminal be node 1 and the lower input terminal be the reference node. The remaining internal nodes may be numbered in any convenient manner. Write a general set of nodal equations and show that the input admittance is equal to the ratio Δ_Y/Δ_{11} .
- ◆3 The reciprocity theorem also holds for the complete response, forced plus natural, if there is no initial energy storage. This restriction is necessary because the network must be passive and have only the one source. Demonstrate the truth of this extension of the reciprocity theorem by: (a) finding i_L in the circuit shown in Fig. 17-16 for $t < 0$ and $t > 0$; (b) interchanging the step-voltage source and the (instantaneous) ammeter and finding the ammeter response for $t < 0$ and $t > 0$.
- 4 In a two-port composed entirely of linear resistors, it is found that if $\mathbf{E}_1 = 100$ volts and $\mathbf{E}_2 = 0$, then $\mathbf{I}_1 = 10$ amp and $\mathbf{I}_2 = 2$ amp. If the short circuit across the output port is replaced by a 20-ohm resistor, then \mathbf{I}_2 drops to 1 amp. The 20-ohm resistor is now removed, the input port is short-circuited, and $\mathbf{E}_2 = 300$ volts. Find \mathbf{I}_1 and \mathbf{I}_2 .
- ◆5 The network shown in Fig. 17-17a contains a dependent voltage source. After writing mesh equations and obtaining the impedance determinant, show that \mathbf{Z}_{12} is not equal to \mathbf{Z}_{21} by finding both.

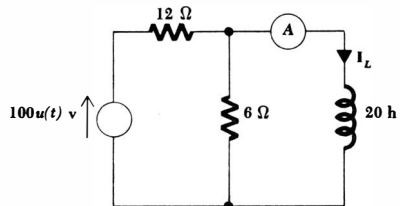

Fig. 17-16 See Prob. 3.

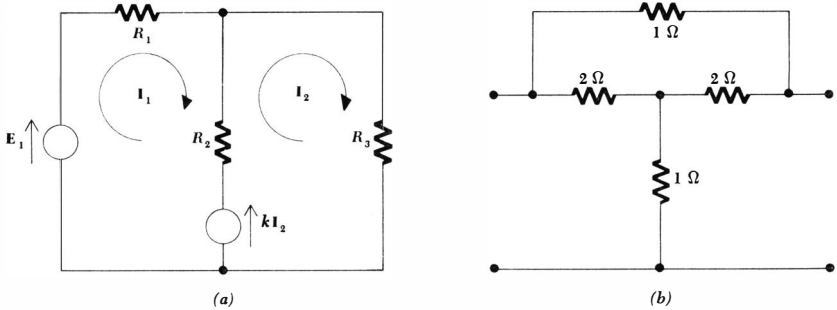

Fig. 17-17 (a) See Prob. 5. (b) See Prob. 6.

- 6 (a) Find the y parameters for the network shown in Fig. 17-17b, and from them derive the equivalent π network. (b) After noting the symmetry exhibited by this network, draw a symmetrical T network, and determine its element values by equating the corresponding y parameters for the given network and the T network.
- 7 (a) Find the y parameters for the network shown in Fig. 17-18a. (b) If the output port is terminated in a 10-ohm resistor and $k = 11$, find the ratio of the power absorbed by the 10-ohm load to that delivered by an input sinusoidal current source I_1 .
- 8 Determine the voltage gains E_2/E_1 and E_2/E_s for the circuit shown in Fig. 17-18b in terms of the y parameters of the two port.
- 9 The circuit shown in Fig. 17-19 is a common equivalent circuit for a transistor operating in the grounded-emitter configuration. The numerical values are realistic. Determine the y parameters.
- 10 The π network of Fig. 17-20a and the T network of Fig. 17-20b are equivalent if the following relationships are satisfied by the impedances of each:

$$\begin{aligned} Z_1 &= \frac{Z_a Z_b}{Z_a + Z_b + Z_c} & Z_a &= \frac{Z_1 Z_2 + Z_2 Z_3 + Z_3 Z_1}{Z_2} \\ Z_2 &= \frac{Z_b Z_c}{Z_a + Z_b + Z_c} & Z_b &= \frac{Z_1 Z_2 + Z_2 Z_3 + Z_3 Z_1}{Z_3} \\ Z_3 &= \frac{Z_c Z_a}{Z_a + Z_b + Z_c} & Z_c &= \frac{Z_1 Z_2 + Z_2 Z_3 + Z_3 Z_1}{Z_1} \end{aligned}$$

The two sets of equations enable the π -T transformation (also called the Y- Δ transformation) to be made in either direction; they are often useful in simplifying networks. Use the y parameters to show that the two networks are equivalent.

- 11 Use the π -T transformation outlined in Prob. 10 to transform the five networks shown in Fig. 17-21.
- 12 Is a π -T transformation made at one frequency valid at every frequency?

541 Two-port Networks

- ◆13 Use the π -T transformation to simplify the circuit shown in Fig. 17-22a and find the power supplied by the source.
- 14 A certain two port has the following z parameters:

$$z_{11} = 20 \text{ ohms} \quad z_{12} = 10 \text{ ohms} \quad z_{21} = 100 \text{ ohms} \quad z_{22} = 110 \text{ ohms}$$

If a $10/\underline{0^\circ}$ volt ideal source is connected to the input terminals and a 25-ohm load resistor is connected across the output terminals, find the voltage across the load.

- ◆15 Find the h parameters for the network shown in Fig. 17-22b.

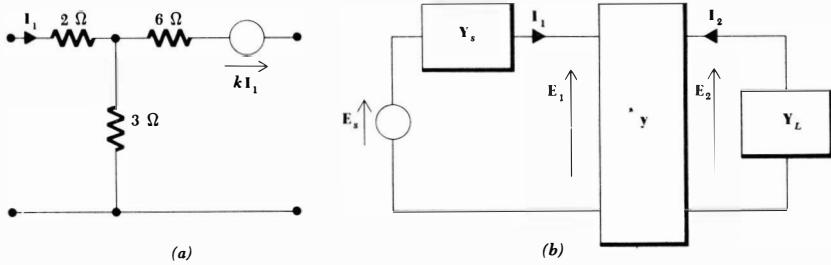

Fig. 17-18 (a) See Prob. 7. (b) See Prob. 8.

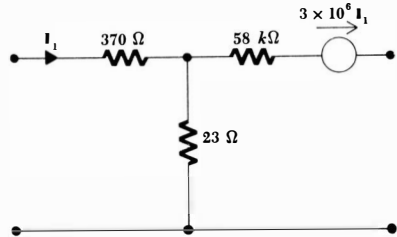

Fig. 17-19. See Probs. 9, 16, and 28.

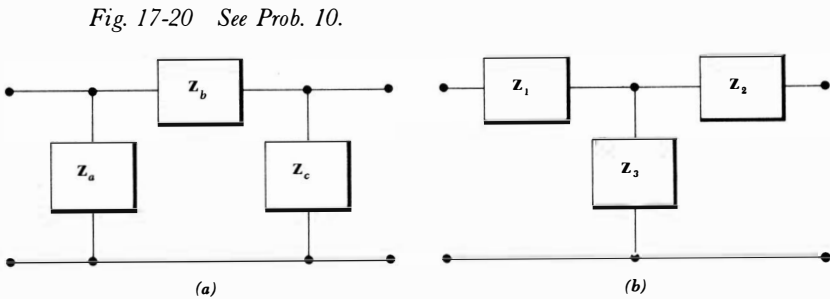

Fig. 17-20 See Prob. 10.

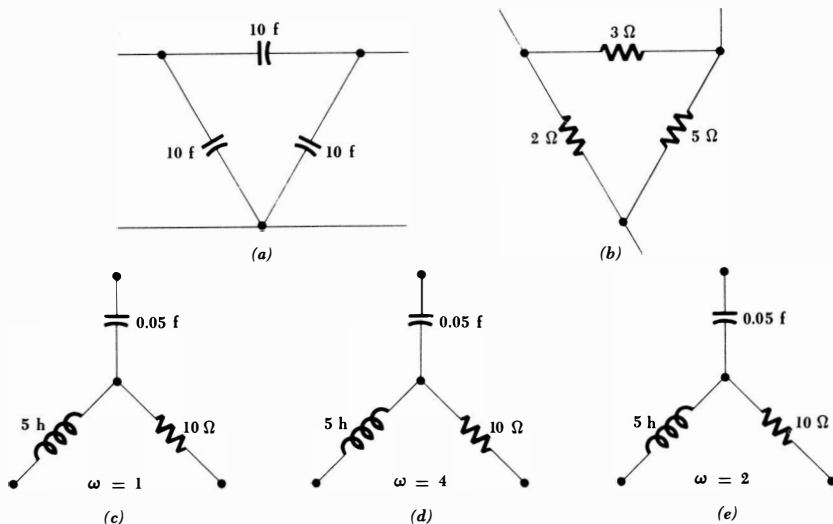

Fig. 17-21 See Prob. 11.

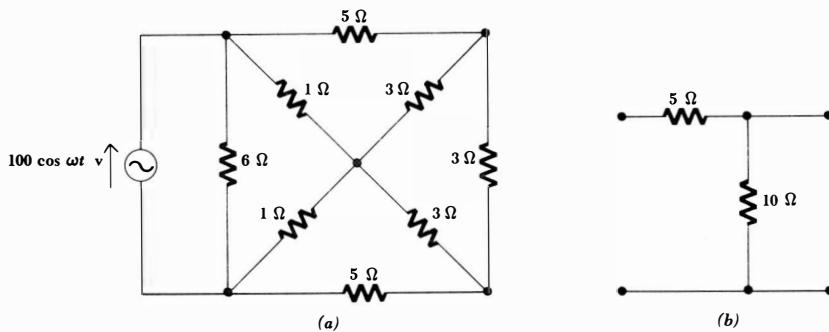
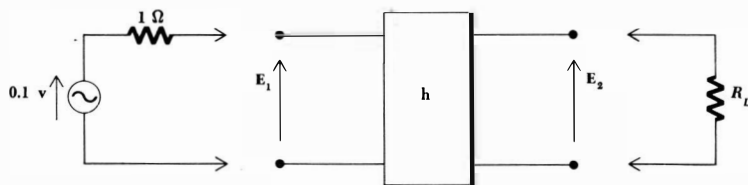

Fig. 17-22 (a) See Prob. 13. (b) See Prob. 15.

Fig. 17-23 See Prob. 18.



- 16 Determine the h parameters for the transistor equivalent circuit shown in Fig. 17-19.
- 17 Given the four h parameters for an electrical two port, determine an equivalent π network in terms of these parameters. Select the equivalent π having one dependent current source across the output port.
- ◆18 The h parameters for the two port sketched in Fig. 17-23 are

$$h_{11} = 2 \text{ ohms} \quad h_{12} = 0.5 \quad h_{21} = 3 \quad h_{22} = 0.4 \text{ mho}$$

A signal generator ($E_{oc} = 0.1 \angle 0^\circ$ volts, $Z_{th} = 1 \angle 0^\circ$ ohm) is to be connected at the input and a load resistor R_L at the output. (a) If the generator is connected but R_L is not, find E_1 and E_2 . (b) If the generator and a 2.5-ohm load resistor are both connected, find E_1 and E_2 . (c) With the load and generator disconnected, find the output impedance. (d) Determine the output impedance with the generator connected.

- 19 Find z_{12} , h_{12} , and y_{12} for the resistive two port shown in Fig. 17-24a.
- ◆20 For the transformer shown in Fig. 17-24b, assume steady-state operation at a complex frequency s . Find: (a) the four y parameters; (b) the four z parameters; (c) the four h parameters.
- 21 The g parameters for a two port are defined by the two equations

$$I_1 = g_{11}E_1 + g_{12}I_2 \quad E_2 = g_{21}E_1 + g_{22}I_2$$

- (a) Find the four g parameters for the network shown in Fig. 17-25a. (b) Find the four g parameters for the network shown in Fig. 17-25b.
- ◆22 A 1-volt source having an internal resistance of 2 ohms is connected to the input terminals of the two-port network shown in Fig. 17-26. A 1-ohm load is connected to the output terminals. Find the load voltage E_2 .

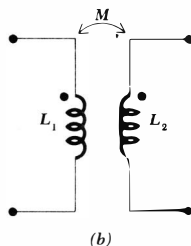
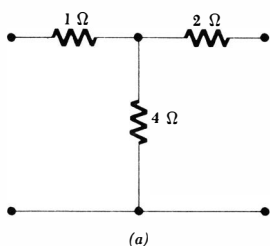

Fig. 17-24 (a) See Prob. 19. (b) See Prob. 20.

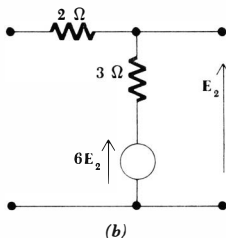
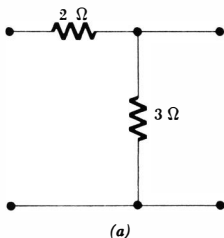

Fig. 17-25 See Prob. 21.

- 23 Find the Thévenin equivalents of the one-port networks shown in Fig. 17-27a and b.
- ◆24 The operation of many triode, tetrode, and pentode vacuum-tube circuits may be analyzed by considering the two port which is equivalent to the tube itself. The equivalence is possible only when the signals throughout the circuit are relatively small so that linear operation may be assumed. The grid G , plate or anode P , and cathode K are identified in Fig. 17-28a. A common-cathode connection is assumed. The low-frequency equivalent circuit, which neglects interelectrode capacitance and lead inductance, is shown in Fig. 17-28b. The plate resistance r_p and transconductance g_m are

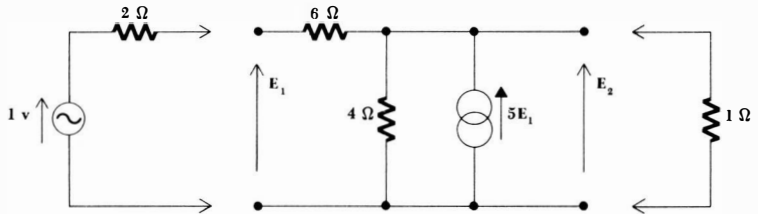

Fig. 17-26 See Prob. 22.

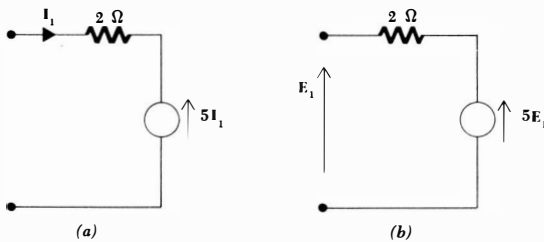

Fig. 17-27 See Prob. 23.

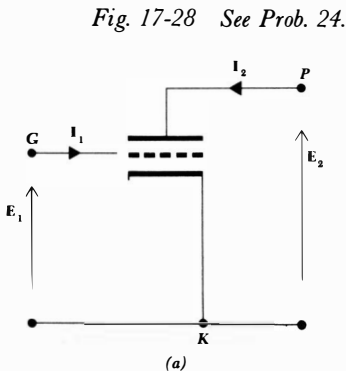

Fig. 17-28 See Prob. 24.

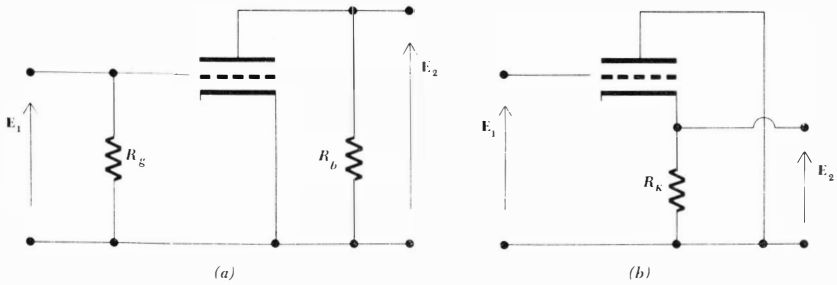

Fig. 17-29 See Prob. 25.

- parameters of the tube and depend on the d-c biasing voltages which need not appear in the equivalent circuit. For this equivalent circuit, find:
- (a) y_{21} ; (b) z_{22} ; (c) h_{22} .
- 25 (a) Replace the vacuum tube in the circuit of Fig. 17-29a with its equivalent circuit (Prob. 24), and determine the voltage gain E_2/E_1 . (b) Repeat for the cathode-follower circuit of Fig. 17-29b. Note that E_1 is no longer the grid-to-cathode voltage, as specified in Fig. 17-28b.
- 26 If $\Delta_k = k_{11}k_{22} - k_{12}k_{21}$, show that the following relationships between the several sets of parameters are correct:

(a) y to z parameters:

$$z_{11} = \frac{y_{22}}{\Delta_y} \quad z_{12} = -\frac{y_{12}}{\Delta_y} \quad z_{21} = -\frac{y_{21}}{\Delta_y} \quad z_{22} = \frac{y_{11}}{\Delta_y}$$

(b) y to h parameters:

$$h_{11} = \frac{1}{y_{11}} \quad h_{12} = -\frac{y_{12}}{y_{11}} \quad h_{21} = \frac{y_{21}}{y_{11}} \quad h_{22} = \frac{\Delta_y}{y_{11}}$$

(c) h to y parameters:

$$y_{11} = \frac{1}{h_{11}} \quad y_{12} = -\frac{h_{12}}{h_{11}} \quad y_{21} = \frac{h_{21}}{h_{11}} \quad y_{22} = \frac{\Delta_h}{h_{11}}$$

(d) z to h parameters:

$$h_{11} = \frac{\Delta_z}{z_{22}} \quad h_{12} = \frac{z_{12}}{z_{22}} \quad h_{21} = -\frac{z_{21}}{z_{22}} \quad h_{22} = \frac{1}{z_{22}}$$

(e) h to z parameters:

$$z_{11} = \frac{\Delta_h}{h_{22}} \quad z_{12} = \frac{h_{12}}{h_{22}} \quad z_{21} = -\frac{h_{21}}{h_{22}} \quad z_{22} = \frac{1}{h_{22}}$$

- 27 (a) Show that the two port of Fig. 17-30a is a possible equivalent network of a general two port. (b) Repeat for the two port of Fig. 17-30b.

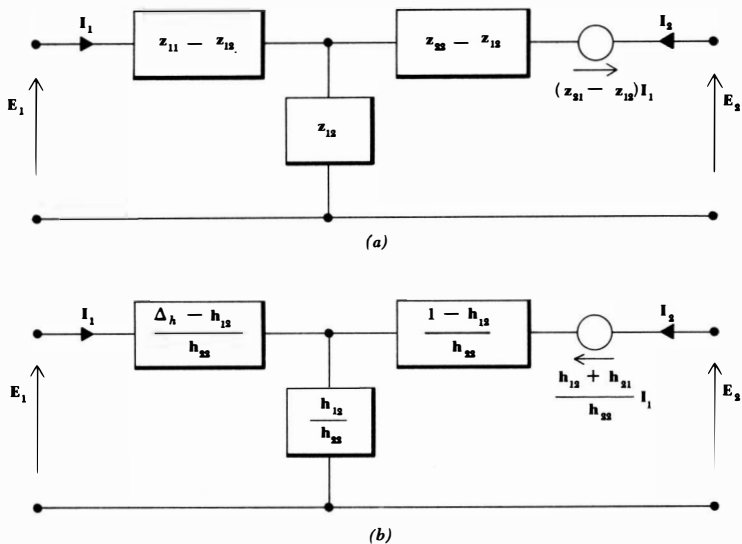

Fig. 17-30 See Prob. 27.

- ◆28 The transistor whose equivalent circuit is shown in Fig. 17-19 is placed between a $10^{-3}/0^\circ$ amp sinusoidal current source, having an output resistance of 100 ohms and a 50,000-ohm load resistor. Determine: (a) the input impedance; (b) the output impedance; (c) the output current; (d) the output voltage; (e) the power gain.

Chapter 18 Network Topology

18-1 INTRODUCTION

We have been so busy learning different methods of circuit analysis and studying these techniques by applying them to relatively simple circuits that we have only rarely been able to consider a fairly complicated network. Such a network, containing a large number of branches and nodes, may be subdued by mesh analysis if it is planar and by nodal analysis under any conditions. Nodal analysis, however, is more directly applicable to a circuit containing only current sources. Suppose that we are given a nonplanar network containing a number of voltage sources. Must we convert each source to a current source and then use nodal analysis, or may we somehow extend the technique of mesh analysis to include such a case? We shall see that the use of loop equations does represent such an extension.

At the same time we shall see that loop currents and loop equations present a new problem; it will be much too easy to write a set of equations which are either dependent or incomplete and, hence, cannot be solved. In order to produce a set of equations which are both independent and sufficient, we must consider those properties of every network which are a function only of the manner by which its several parts are interconnected and which are not a function of the particular types of elements used. These properties are the concern of a branch of geometry called *topology*.

In a similar way we shall extend the use of nodal analysis and rely on topology again to help us obtain an independent, sufficient set of equations.

Finally, we shall need to determine whether a given network should be attacked by loop analysis or by nodal analysis; topology will also help us make this choice.

In order to convince ourselves that it is quite easy to obtain an incorrect set of equations, it is helpful to begin by considering a simple circuit as an example. We shall first analyze the resistive bridge circuit of Fig. 18-1a correctly by

selecting mesh currents, as shown on the circuit diagram. The mesh equations are

$$\begin{aligned} 4\mathbf{I}_1 - 3\mathbf{I}_2 - \mathbf{I}_3 &= 9 \\ -3\mathbf{I}_1 + 5\mathbf{I}_2 - \mathbf{I}_3 &= 0 \\ -\mathbf{I}_1 - \mathbf{I}_2 + 3\mathbf{I}_3 &= 0 \end{aligned}$$

We thus find \mathbf{I}_x by the difference:

$$\mathbf{I}_x = \mathbf{I}_3 - \mathbf{I}_2 = \frac{\begin{vmatrix} 4 & -3 & 9 \\ -3 & 5 & 0 \\ -1 & -1 & 0 \end{vmatrix} - \begin{vmatrix} 4 & 9 & -1 \\ -3 & 0 & -1 \\ -1 & 0 & 3 \end{vmatrix}}{\begin{vmatrix} 4 & -3 & -1 \\ -3 & 5 & -1 \\ -1 & -1 & 3 \end{vmatrix}} = \frac{72 - 90}{56 - 30 - 8} = -1$$

Of course, we might wish to avoid the evaluation of three determinants by re-drawing the circuit in such a way that \mathbf{I}_x may be identified directly as one of the mesh currents. This is done correctly in Fig. 18-1*b*, and it is evident that

$$\begin{aligned} 5\mathbf{I}_1 - 3\mathbf{I}_2 - \mathbf{I}_3 &= 0 \\ -3\mathbf{I}_1 + 4\mathbf{I}_2 &= -9 \\ -\mathbf{I}_1 &+ 2\mathbf{I}_3 = 9 \end{aligned}$$

$$\mathbf{I}_x = \frac{\begin{vmatrix} 0 & -3 & -1 \\ -9 & 4 & 0 \\ 9 & 0 & 2 \end{vmatrix}}{\begin{vmatrix} 5 & -3 & -1 \\ -3 & 4 & 0 \\ -1 & 0 & 2 \end{vmatrix}} = \frac{-54 + 36}{40 - 18 - 4} = -1 \text{ amp}$$

Now let us again consider this circuit in the form in which it was first drawn, repeated in Fig. 18-2*a*. Instead of selecting mesh currents, a process which we have grown to trust (and rightly so), let us now choose three *loop* currents. We have only our intuition to guide us at present, but three currents are correctly selected on the circuit diagram, Fig. 18-2*a*. We first note that $\mathbf{I}_x = \mathbf{I}_3$. We now must be careful because two loop currents may flow *in the same direction* through an element which is common to the two loops, such as the lower right 1-ohm resistor through which both \mathbf{I}_2 and \mathbf{I}_3 flow in the same direction.

The three Kirchhoff voltage equations are then

$$\begin{aligned} 4\mathbf{I}_1 - 4\mathbf{I}_2 - \mathbf{I}_3 &= 9 \\ -4\mathbf{I}_1 + 6\mathbf{I}_2 + 2\mathbf{I}_3 &= 0 \\ -\mathbf{I}_1 + 2\mathbf{I}_2 + 3\mathbf{I}_3 &= 0 \end{aligned}$$

$$\text{and } \mathbf{I}_x = \mathbf{I}_3 = \frac{\begin{vmatrix} 4 & -4 & 9 \\ -4 & 6 & 0 \\ -1 & 2 & 0 \end{vmatrix}}{\begin{vmatrix} 4 & -4 & -1 \\ -4 & 6 & 2 \\ -1 & 2 & 3 \end{vmatrix}} = \frac{-18}{56 - 40 + 2} = -1$$

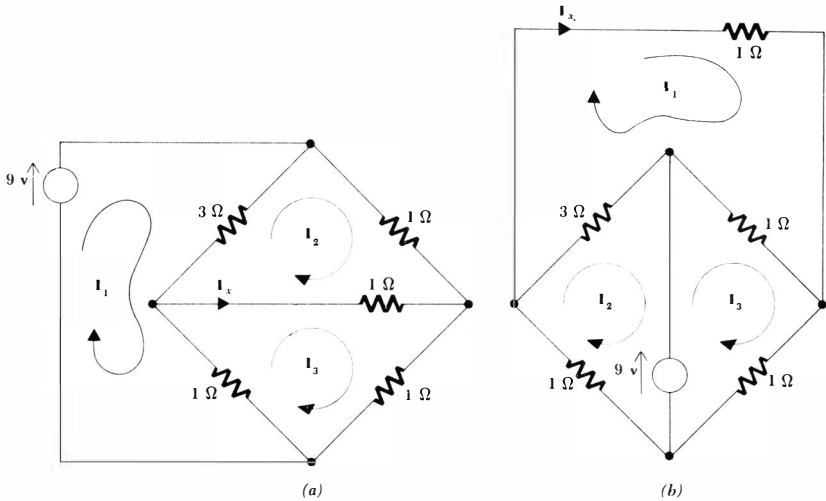

Fig. 18-1 (a) A given unbalanced bridge with three mesh currents indicated. (b) The same circuit redrawn so that I_x may be identified as a mesh current.

Some of the terms in these equations, or elements in the determinants, which we have been accustomed to see carrying a minus sign are now positive; this is characteristic of loop analysis. The method and result are both correct.

Now let us go one step further. Our intuition might lead us astray by telling us that a smaller number of loop currents could be selected as long as every branch is traversed. Such a set of *two* loop currents is indicated in Fig. 18-2b. Then

$$I_x = I_1 = \frac{\begin{vmatrix} 9 & -3 & +1 \\ 0 & 6 & \end{vmatrix}}{\begin{vmatrix} 5 & -3 & +1 \\ -3 & +1 & 6 \end{vmatrix}} = \frac{27}{13} \quad (\text{wrong})$$

and a wrong answer is obtained. There is no warning either; no zeros, no infinities, no indeterminate forms—just a wrong number. Perhaps we feel that since three mesh currents are needed, then three loop currents should be chosen. This is true but we cannot rely on such a guide where nonplanar networks are concerned because mesh analysis and mesh currents are not applicable.

The necessary number of loop currents and the permissible ways in which they may be selected are easily found with a little knowledge of network topology.

Before leaving the example of Fig. 18-2b and the incorrect solution obtained for that circuit, it may be pointed out that the fallacy lies in the fact that the current I_1 is the only current flowing in the source and it is also the only current

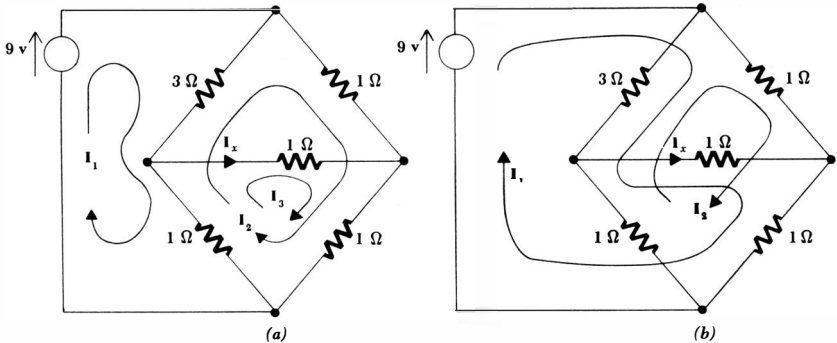

Fig. 18-2 (a) Three loop currents are selected for the circuit first shown in Fig. 18-1a. (b) Two loop currents are selected such that every branch is in one of the loops. This leads to a wrong answer.

flowing in the detector arm of the bridge. Our knowledge of bridge circuits should have indicated to us that these two currents are not in general the same.

Drill Problem

18-1 Analyze the circuit of Fig. 18-1 for I_x by using the loop currents shown on the sketches of Fig. 18-3a, b, and c.

Ans. -1 amp; -1 amp; -1 amp

18-2 SOME TOPOLOGICAL DEFINITIONS

In order to develop several helpful topological facts about networks, we must first define topology itself and then define several terms which will enable us to describe a network topologically. Many of these terms are already familiar ones. *Topology* itself is a branch of geometry which is concerned with those properties of a geometrical figure which are unchanged when the figure is twisted, bent, folded, stretched, squeezed, or tied in knots, with the provision that no parts of the figure are to be cut apart or to be joined together. A sphere and a tetrahedron are topologically identical, as are a square and a circle. In terms of electric circuits, then, we are not now concerned with the particular types of elements appearing in the circuit, but only with the way in which branches and nodes are arranged. As a matter of fact, we usually suppress the nature of the elements and simplify the drawing of the circuit by showing the elements as straight lines. The resultant drawing is called a *linear graph*, or simply a *graph*. A circuit and its graph are shown in Fig. 18-4. Note that all nodes are identified by heavy dots in the graph.

Since the topological properties of the circuit or its graph are unchanged

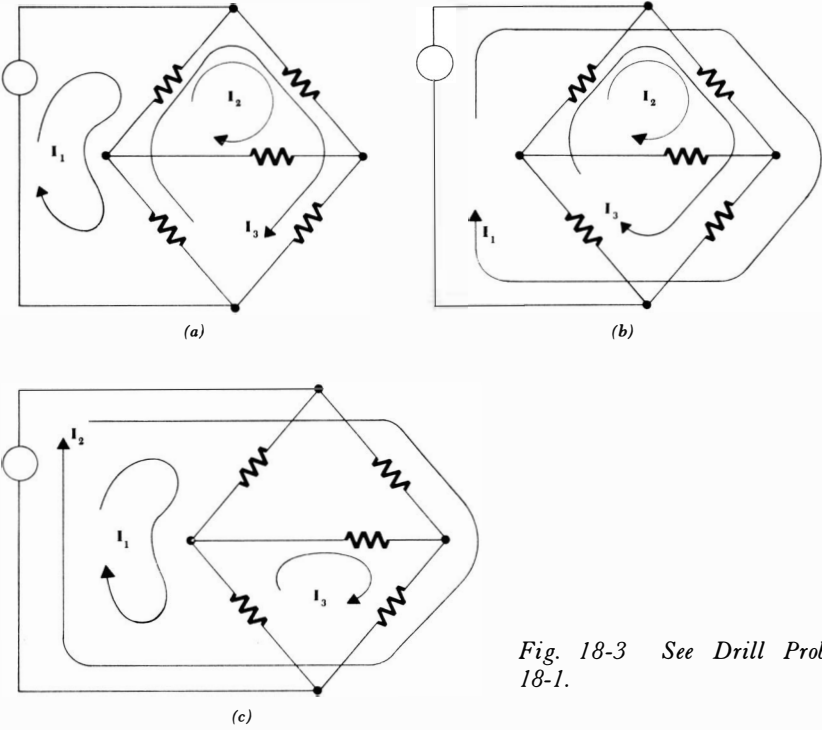
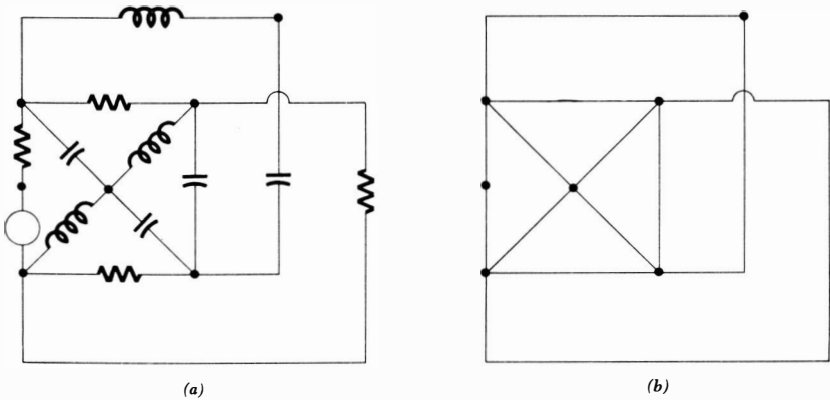

Fig. 18-3 See Drill Prob. 18-1.

Fig. 18-4 (a) A given electrical circuit. (b) The linear graph of this circuit.



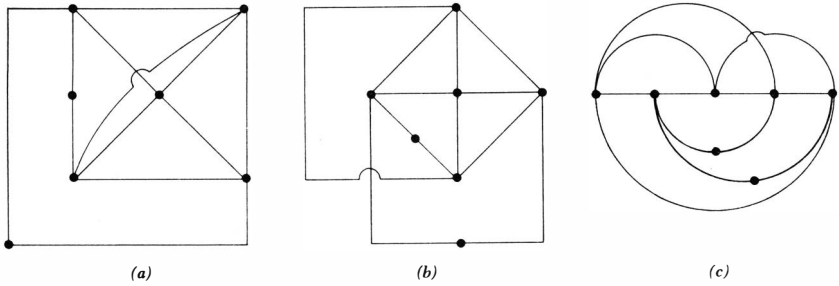

Fig. 18-5 The three graphs shown are topologically identical to each other and to the graph of Fig. 18-4b, and each is a graph of the circuit shown in Fig. 18-4a.

when it is distorted, the three graphs shown in Fig. 18-5 are all topologically identical with the circuit and graph of Fig. 18-4.

Topological terms which we already know and have been using correctly are:

- node:** a point at which two or more elements have a common connection.
- branch:** a single path, containing one simple element, which connects one node to any other node.
- loop:** a set of branches forming a closed path which passes through no node more than once.

Since a *mesh* may exist or disappear as a network is drawn in planar or non-planar form, it is evident that it cannot be topological property.

The graphs of Fig. 18-5 each contain 12 branches and 7 nodes.

Two new properties of a linear graph must now be defined, a tree and a link. We may define a *tree* as any set of branches which does not contain any loops but which connects every node to every other node, not necessarily directly. There are usually a number of different trees which may be drawn for a network, and the number increases rapidly as the complexity of the network increases. The simple graph shown in Fig. 18-6a has eight possible trees, four of which are shown by heavy lines in Fig. 18-6b, c, d, and e.

In Fig. 18-7a a more complex graph is shown. Figure 18-7b shows one possible tree, and Fig. 18-7c and d show sets of branches which are *not* trees because neither set satisfies the definition above.

Fig. 18-6 (a) The linear graph of a three-node network. (b), (c), (d), and (e) Four of the eight different trees which may be drawn for this graph are shown by the heavy lines.

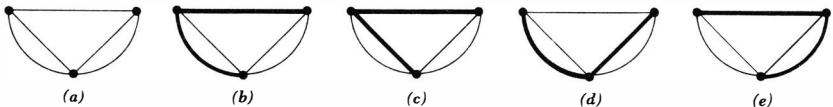

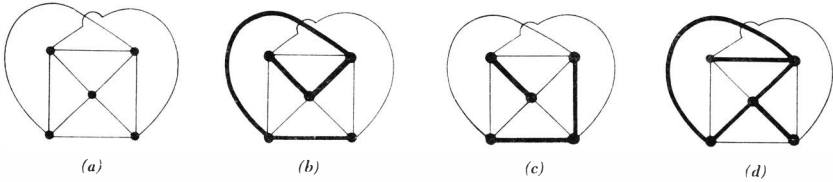

Fig. 18-7 (a) A linear graph. (b) A possible tree for this graph. (c) and (d) These sets of branches do not satisfy the definition of a tree.

Once we understand the construction of a tree, the concept of the link is very simple, for a *link* is any branch in a linear graph which is not a branch of the tree. It is evident that any particular branch may or may not be a link, depending on the particular tree which is selected.

The number of links in a graph may be related to the number of branches and nodes very simply. If the graph has N nodes, then exactly $N - 1$ branches are required to construct a tree because the first branch chosen connects two nodes and each additional branch includes one more node. Thus, given B branches, the number of links L must be

$$L = B - (N - 1)$$

or
$$L = B - N + 1 \tag{18-1}$$

In any of the graphs shown in Fig. 18-6, we note that $3 = 5 - 3 + 1$, and in the graph of Fig. 18-7b, $6 = 10 - 5 + 1$. When we considered mutual inductance and magnetic coupling in Chap. 16, we saw that a network may be in several disconnected parts. Equation (18-1) may be made more general by replacing $+1$ with $+S$, where S is the number of separate parts. However, it is also possible to connect two separate parts by a *single* conductor, thus causing two nodes to form one node; no current can flow through this single conductor. This process may be used to join any number of separate parts, and thus we shall not suffer any loss of generality if we restrict our attention to circuits for which $S = 1$.

Drill Problems

18-2 Determine the number of branches, nodes, and links in the graphs of the circuits shown in Fig. 18-8a, b, and c. Check the answers by constructing a tree for each circuit.

Ans. 16, 7, 10; 12, 8, 5; 21, 13, 9

18-3 A node is defined as the junction of two or more branches, and a branch is defined as being equivalent to a single element. Suppose that a node is defined as the junction of *three* or more branches, and a branch is defined as the single path containing one or more simple elements in series which connects one node to another node. Using these different definitions, determine the number of branches, nodes, and links in the

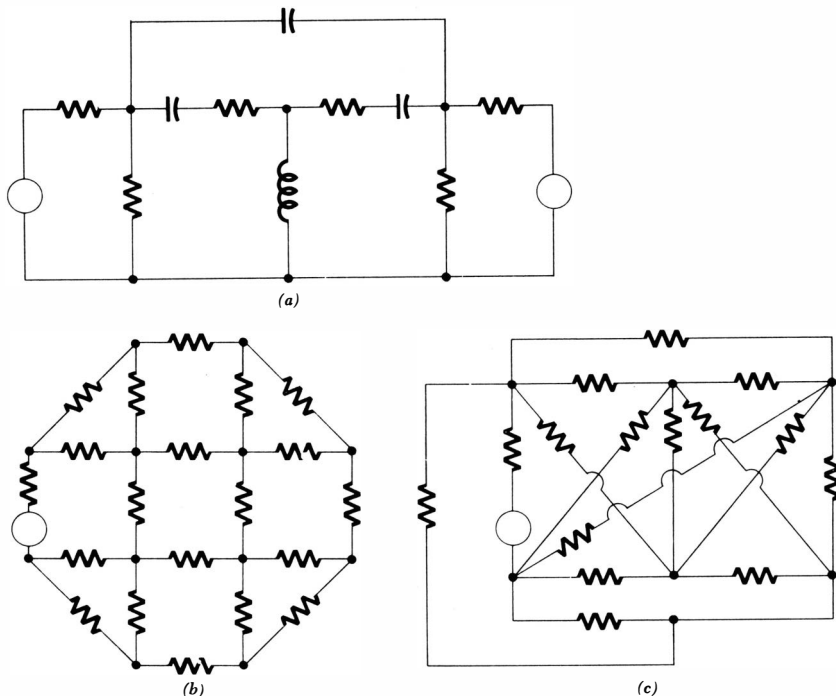

Fig. 18-8 See Prob. 4 and Drill Probs. 18-2 and 18-3.

graphs of the circuits shown in Fig. 18-8a, b, and c, and show that the equation $L = B - N + 1$ is still satisfied.

Ans. 15, 6, 10; 8, 4, 5; 20, 12, 9

18-3 WRITING INDEPENDENT LOOP EQUATIONS

We are now ready to discuss a method whereby a set of loop equations may be written for a network that are independent and sufficient. The method will enable us to obtain many different sets of equations for the same network, and all the sets will be valid. However, the method does not provide us with *every* possible set of equations. Let us first describe the procedure, illustrate it by an example, and then point out the reason that the equations are independent and sufficient.

Given a network, we first draw its graph and then construct a tree. Any tree will do, and we shall see shortly how to choose that tree which is most convenient for our purposes. We next focus our attention on any arbitrary link. If that link is added to the tree, a closed loop must be formed; to this loop we assign our first loop current. It flows through certain branches in the tree and

through this particular link. Now let us temporarily ignore that first link and the first loop current. We select another link, imagine its addition to the tree, note that once again a loop is formed, and assign our second loop current to this loop. The process is repeated for each link and, since there are $B - N + 1$ links, we end up with $B - N + 1$ loop currents; no link has more than one loop current flowing in it. The procedure is now familiar; Kirchhoff's voltage law is applied to each loop, as defined by its loop current, and the resultant equations may be solved by determinants, substitution, inspection, or digital computer.

Let us consider the familiar circuit redrawn in Fig. 18-9a. We are asked for I_x once more. Since no link carries more than one loop current, we therefore construct a tree so that the branch in which I_x appears is a link. Several trees are possible, and the one arbitrarily selected is indicated in Fig. 18-9b. We now select a link, such as that defining I_x , and assign a loop current which flows through that link but no other link. This current is shown on Fig. 18-9b as I_1 , the clockwise direction being assumed only out of habit. The next link might be the source link, and this establishes the loop current I_2 . Finally, I_3 is selected in the remaining link. It should be noted that, once the tree is drawn, the loops are then fixed. Only the direction of the loop current is a free choice, and this is of course immaterial. The loop equations are

$$\begin{aligned} 5I_1 + I_2 + 4I_3 &= 0 \\ I_1 + 2I_2 + 2I_3 &= 9 \\ 4I_1 + 2I_2 + 6I_3 &= 0 \end{aligned}$$

and thus I_1 is

$$I_1 = \begin{vmatrix} 0 & 1 & 4 \\ 9 & 2 & 2 \\ 0 & 2 & 6 \\ \hline 5 & 1 & 4 \\ 1 & 2 & 2 \\ 4 & 2 & 6 \end{vmatrix} = \frac{-9(-2)}{5(8) - 1(-2) + 4(-6)} = 1$$

Fig. 18-9 (a) The given circuit. (b) A tree is selected in which the I_x branch is a link.

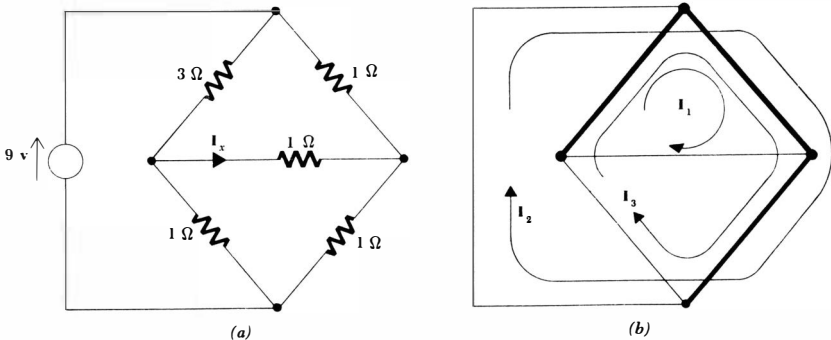

This checks the result we obtained for this same circuit earlier in this chapter.

Now let us discuss the sufficiency of the assumed currents and the independence of the loop equations. If these loop currents are *sufficient*, then every branch current may be obtained from a knowledge of the values of all the loop currents. Once every branch current is known, it is apparent that every branch voltage or power can be readily obtained and thus the loop currents will be “sufficient” information to enable a complete solution to be obtained if desired.

How may we demonstrate sufficiency? Let us visualize a tree. It contains no loops and therefore contains at least two nodes to each of which only one tree branch is connected. The current in each of these two branches is easily found from the known link currents by applying Kirchhoff’s current law. If there are other nodes at which only one tree branch is connected, these tree-branch currents may also be immediately obtained. In the tree shown in Fig. 18-10, we thus have found the currents in branches *a*, *b*, *c*, and *d*. Now we move along the branches of the tree, finding the currents in the tree branches *e* and *f*; the process may be continued until all the branch currents are determined. The link currents are therefore sufficient to determine all branch currents. It is helpful to look at the situation where an incorrect “tree” has been drawn which contains a loop. Even if all the link currents were zero, a current might still circulate about this “tree loop.” Hence, the link currents could not determine this current, and they would not represent a sufficient set. Such a “tree” is by definition impossible.

In order to demonstrate that the $B - N + 1$ loop equations are independent, it is only necessary to point out that each represents the application of Kirchhoff’s voltage law around a loop which contains one link not appearing in any other equation. We might visualize a different impedance $Z_1, Z_2, \dots, Z_{B-N+1}$ in each of these links, and it is then apparent that one equation can never be obtained from the others since it contains one coefficient not appearing in any other equation.

Hence, the link currents are sufficient to enable a complete solution to be obtained, and the set of loop equations which we use to find the link currents is a set of independent equations.

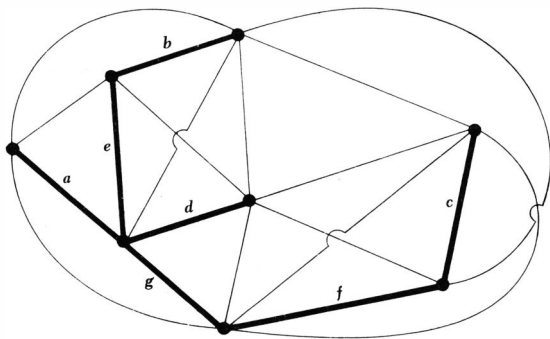

Fig. 18-10 A tree which is used as an example to illustrate the sufficiency of the link currents.

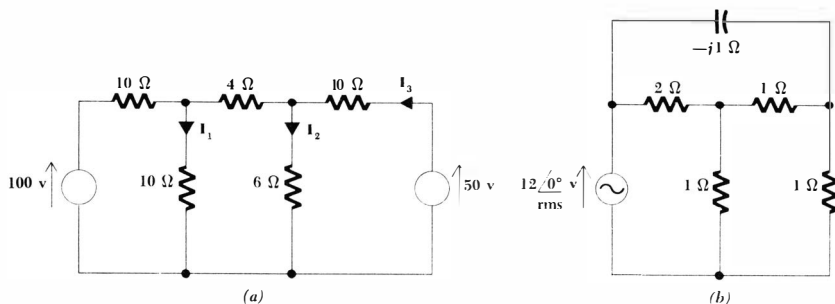

Fig. 18-11 (a) See Drill Prob. 18-4. (b) See Drill Prob. 18-5.

Drill Problems

18-4 Draw a tree for the circuit shown in Fig. 18-11a so that I_1 , I_2 , and I_3 are link currents. Find them by writing loop equations.

Ans. 3.77 amp; 2.21 amp; 4.66 amp

18-5 Find the power dissipated in each 1-ohm resistor of the network shown in Fig. 18-11b.

Ans. 8.09 watts; 42.1 watts; 21.0 watts

18-4 WRITING INDEPENDENT NODAL EQUATIONS

Now we shall consider the use of a tree to obtain a suitable set of nodal equations. In some respects this is the dual of the method of writing loop equations. Again it should be pointed out that, although we are able to guarantee that any set of equations we write will be both sufficient and independent, we should not expect that the method will lead directly to every possible set of equations.

We begin by constructing any convenient tree for the given network and then focus our attention on the branches in the tree. Each tree branch is assigned a voltage, extending from the node at one end of the tree branch to the other. Thus, there are $N - 1$ voltages chosen since the tree contains $N - 1$ branches. Kirchhoff's current law is then applied to any $N - 1$ nodes, and the remaining node may be ignored. This corresponds to the presence of the reference node in our previous attack on nodal analysis. The equation written at the N th node is not independent; it may be obtained from the other $N - 1$ equations.

The procedure may be illustrated by considering the example shown in Fig. 18-12a. We first draw a tree containing the I_x branch, such as that shown in Fig. 18-12b, and then select voltages across the three tree branches as E_1 , E_2 , and E_3 . The three voltages may be sensed in any direction. At the upper node,

$$3E_1 + 1(E_1 + E_2) = 9$$

or
$$4E_1 + E_2 = 9$$

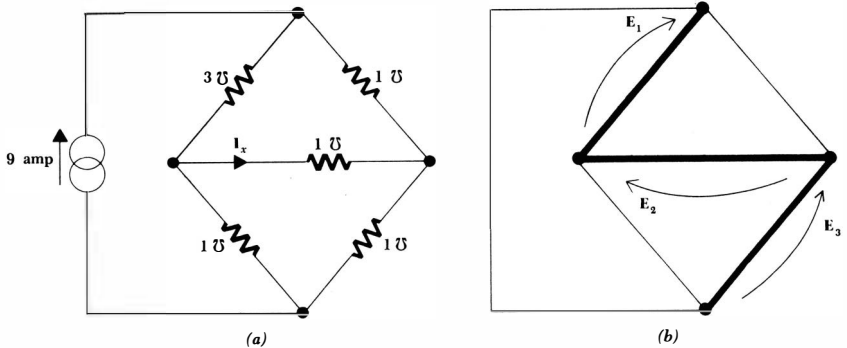

Fig. 18-12 (a) The given network. (b) A tree is chosen in which the I_x branch is one of the tree branches.

at the left node,

$$-3E_1 + 1E_2 + 1(E_2 + E_3) = 0$$

or
$$-3E_1 + 2E_2 + E_3 = 0$$

and at the right node,

$$-1(E_1 + E_2) - 1E_2 + 1E_3 = 0$$

or
$$-E_1 - 2E_2 + E_3 = 0$$

Therefore,

$$\mathbf{E}_2 = \frac{\begin{vmatrix} 4 & 9 & 0 \\ -3 & 0 & 1 \\ -1 & 0 & 1 \end{vmatrix}}{\begin{vmatrix} 4 & 1 & 0 \\ -3 & 2 & 1 \\ -1 & -2 & 1 \end{vmatrix}} = \frac{-9(-3 + 1)}{4(4) + 3(1) - 1(1)} = 1$$

The above equations and the denominator determinant both exhibit a startling difference from past performance. The symmetry about the main diagonal has vanished. This symmetry was present when all nodal voltages were taken with respect to a single reference node, and it was present in all the loop equations discussed in the previous section. It is a useful guard against careless mistakes, and we shall miss it. Symmetry exists in the loop equations because an element Z_{ij} present in loops i and j has loop currents I_i and I_j flowing through it and thus has voltages $\pm I_i Z_{ij}$ and $\pm I_j Z_{ij}$ produced across it. In the general nodal analysis, however, we cannot in general associate a particular branch voltage with a particular node; a common reference node no longer exists.

With a little ingenuity, however, we may construct a tree for any network

such that the tree possesses a common reference node; that is, one node is common to every branch in the tree. Consider the simple circuit shown in Fig. 18-13a. Although we should certainly analyze this network by writing a single loop or mesh equation, let us consider nodal analysis. Four nodes are present, and apparently any tree we draw will contain three branches in series and thus not possess a common reference node. If we add a zero-conductance branch between, say, nodes 2 and 4, then the tree shown in Fig. 18-13b possesses a possible reference node, node 4. We should write the equations

$$\begin{aligned} E_1 &= 60 \\ -\frac{1}{2}E_1 + (\frac{1}{5} + \frac{1}{10} + 0)E_2 - \frac{1}{10}E_3 &= 0 \\ -\frac{1}{10}E_2 + (\frac{1}{10} + \frac{1}{15})E_3 &= 0 \end{aligned}$$

and obtain the obviously correct solutions $E_2 = 50$ volts, $E_3 = 30$ volts.

The tree-branch voltages are *sufficient* to allow the link voltages to be determined. This is apparent because each link extends between two nodes which are also connected by a sequence of tree branches, or known voltages. The node equations also form an *independent* set of equations. If we imagine an admittance Y_1, Y_2, \dots, Y_{N-1} connected from each node to that node at which Kirchhoff's current law is not applied, then it is obvious that none of the equations can be obtained from any of the others.

Drill Problems

18-6 In the circuit shown in Fig. 18-14a, choose a tree so that nodal equations may be written in terms of the three source voltages. Determine the power delivered by each source.

Ans. 3.56 watts; 13.44 watts; 0.912 watt

18-7 Find $E_1, E_2,$ and E_3 in the circuit shown in Fig. 18-14b.

Ans. -5.68 volts; -1.44 volts; 4.24 volts

Fig. 18-13 (a) A given network for which no tree can be drawn which contains a common reference node. (b) The addition of a zero-admittance branch between nodes 2 and 4 permits a tree to be drawn in which node 4 is a common reference node.

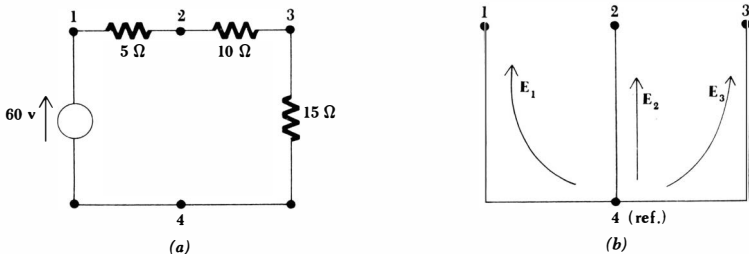

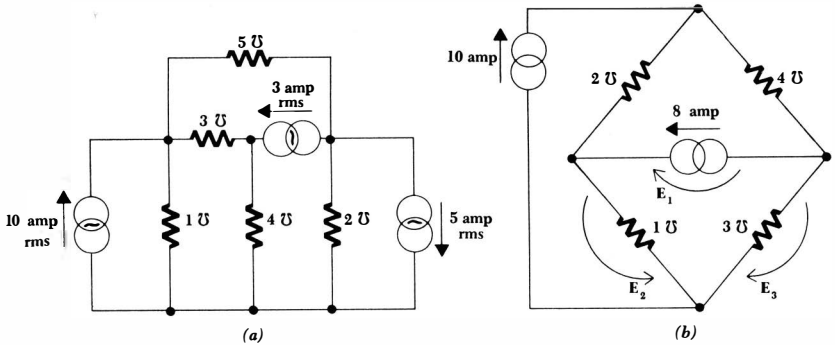

Fig. 18-14 (a) See Drill Prob. 18-6. (b) See Drill Prob. 18-7.

18-5 THE CHOICE BETWEEN LOOP AND NODAL METHODS

Which of the two methods loop analysis or nodal analysis is preferable? The answer depends mostly on the form of the circuit in question. It is evident that $N - 1$ nodal equations are required and $B - N + 1$ loop equations are needed. Other things being equal, we should certainly choose that method which requires the smaller number of equations.

There is a strong tendency among students, professional engineers, and the authors to use mesh or loop analysis more often than they should. This is partly due to the fact that circuit diagrams usually carry resistance values rather than conductance values and the extra step of finding conductances can be avoided by using loop analysis. This is not a very good alibi when capacitance and inductance are also present. Another reason for the emphasis on loop analysis is probably the tendency in all of us to learn well one method that we can always apply, even if it occasionally means extra work. Nodal analysis is very convenient in many electronic circuits in which loop analysis is almost prohibitively involved.

We must also consider the problem of sources once more. Nodal analysis applies naturally to circuits containing current sources and loop or mesh analysis to circuits containing voltage sources. Of course, these sources may be transformed into each other very simply in most cases.

Let us consider an example in which the sources cannot be transformed by the simple methods. To lighten the algebraic load, we consider a purely resistive circuit, shown in Fig. 18-15a. We should note that neither source can be transformed (only because each one is assumed ideal), and we should also see that superposition would lead to the most rapid solution. Let us avoid this simple method and worry about applying mesh or nodal analysis. Neither is obviously preferable, so we shall write nodal equations first. Since the voltage across the ideal voltage source is given, we shall select this branch as a tree branch. The tree chosen is sketched in Fig. 18-15b, and the three branch voltages are indicated. The three equations are

561 Network Topology

$$\begin{aligned} e_1 &= 10 \\ 1(e_2 - e_1) + \frac{1}{2}e_2 &= 10 \\ \frac{1}{3}(e_3 - e_1) + 1e_3 &= -10 \end{aligned}$$

Hence,

$$\begin{aligned} 1.5e_2 - 10 &= 10 \\ e_2 &= 13.33 \end{aligned}$$

and
$$\begin{aligned} 1.333e_3 - 3.333 &= -10 \\ e_3 &= -5 \end{aligned}$$

In a more complicated circuit, the set of equations might be solved by determinants.

If we now try loop analysis, we should select the ideal current source as a link since its current is already known. The tree of Fig. 18-15b is again satisfactory, and the loop currents are indicated on it. The three loop equations are

$$\begin{aligned} i_1 &= 10 \\ 2i_1 + 3i_2 &= 10 \\ -i_1 + 4i_3 &= 10 \end{aligned}$$

Hence,

$$-10 + 4i_3 = 10$$

and
$$i_3 = 5$$

Thus,

$$20 + 3i_2 = 10$$

and
$$i_2 = -3.333$$

Again, determinants may be used if necessary.

Fig. 18-15 (a) A circuit is shown containing two ideal sources which cannot be simply transformed. (b) A tree is selected for nodal analysis.

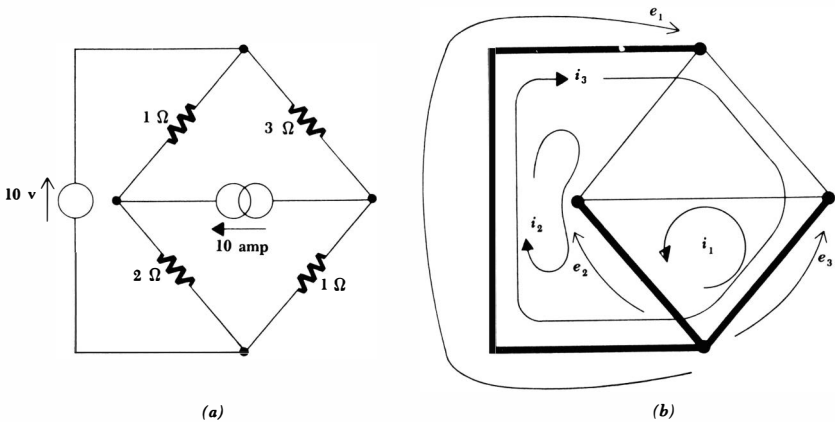

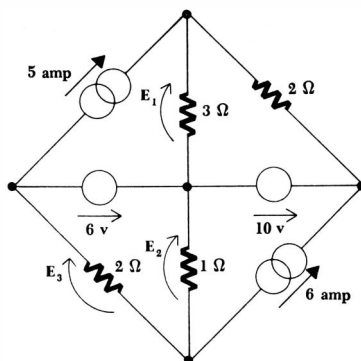

Fig. 18-16 See Drill Probs. 18-8 and 18-9 and Probs. 17 and 18.

With somewhat more work, problems such as these may also be analyzed by placing a resistor in series with each ideal voltage source or in parallel with each current source, transforming the sources, analyzing the resultant circuits by standard loop or nodal methods, and then letting the parallel resistors become infinite or the series resistors approach zero.

Drill Problems

18-8 Analyze the circuit of Fig. 18-16 by writing nodal equations. Determine the value of E_1 , E_2 , and E_3 .

Ans. 6 volts; 12 volts; 0 volts

18-9 Write mesh equations for the circuit of Fig. 18-16 and again determine E_1 , E_2 , and E_3 .

Ans. 6 volts; 12 volts; 0 volts

Problems

- ◆1 For the circuit shown in Fig. 18-17a find I_x by: (a) using mesh currents I_1 , I_2 , and I_3 shown; (b) redrawing the network so that each source is in only one mesh and then reassigning mesh currents; (c) leaving the configuration as shown, drawing a tree which does not include either source branch, and assigning suitable loop currents.
- 2 Show that $L = B - N + 1$ for the circuits of Fig. 18-17a and b.
- 3 How many different trees can be drawn for the circuits of Fig. ◆18-18a and 18-18b?
- 4 (a) For the circuit of Fig. 18-8b, draw any tree, number the link currents from I_1 to I_{B-N+1} , assume $I_1 = 1$, $I_2 = 2$, $I_3 = 3$, etc., using whichever sense you desire, and show that all the branch currents are determined by finding their values, including direction. (b) How many mesh currents must be defined in this circuit? Does this equal the above number of link

- currents? (c) Show that no tree can be constructed so that the link currents will be mesh currents.
- ◆5 A resistor is located along each edge of a cube, and a voltage source, including a series resistor, is connected between two diametrically opposite corners. How many loop equations are required?
 - 6 Draw any tree for the parallel-T notch filter shown in Fig. 18-19a. Find the number of: (a) nodes; (b) branches; (c) tree branches; (d) links; (e) loop equations necessary for a solution.
 - 7 By drawing a tree for the circuit of Fig. 18-19b, show that E_1 , E_2 , and E_3 are a sufficient set of node voltages. Write three nodal equations and determine these voltages.
 - ◆8 In the circuit shown in Fig. 18-20a: (a) How many nodal equations must be written? (b) May E_A , E_B , and E_C be used as a suitable set of node voltages? (c) Show that E_A , E_E , and E_C are a suitable set and use them to find

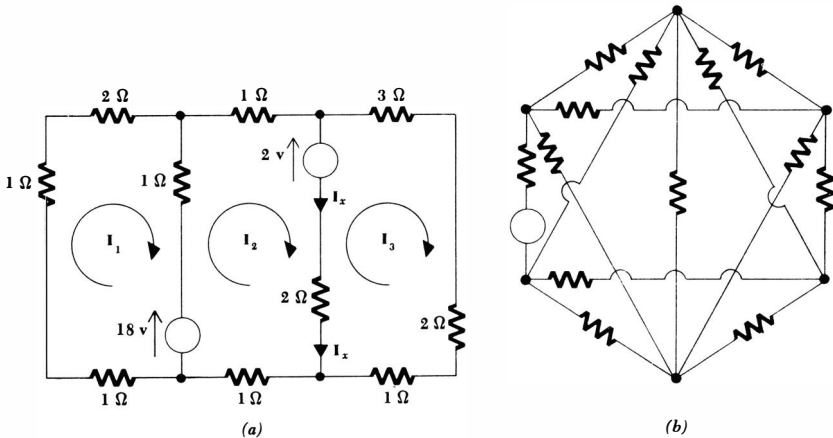
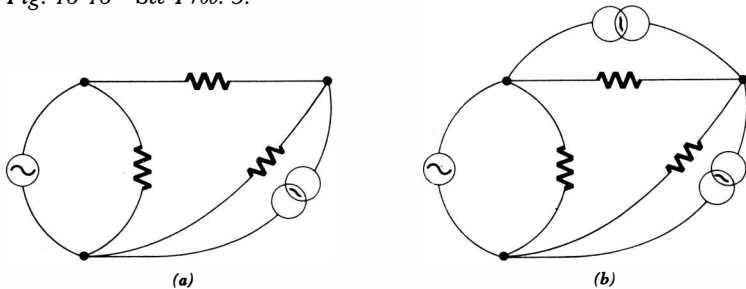

Fig. 18-17 (a) See Prob. 1 and Prob. 2. (b) See Prob. 2.

Fig. 18-18 See Prob. 3.



the current in the 2-mho conductance. (d) Repeat part c for the set of voltages E_D , E_E , and E_F .

- 9 S_1 and S_2 may be considered either as general voltage or general current sources in Fig. 18-20b, and A , B , C , D , and E either as impedances or admittances. (a) How many loop equations are required? (b) How many nodal equations are required? (c) Draw a tree so that the voltages across B , across C , and across E are nodal voltages. (d) Draw a tree so that both

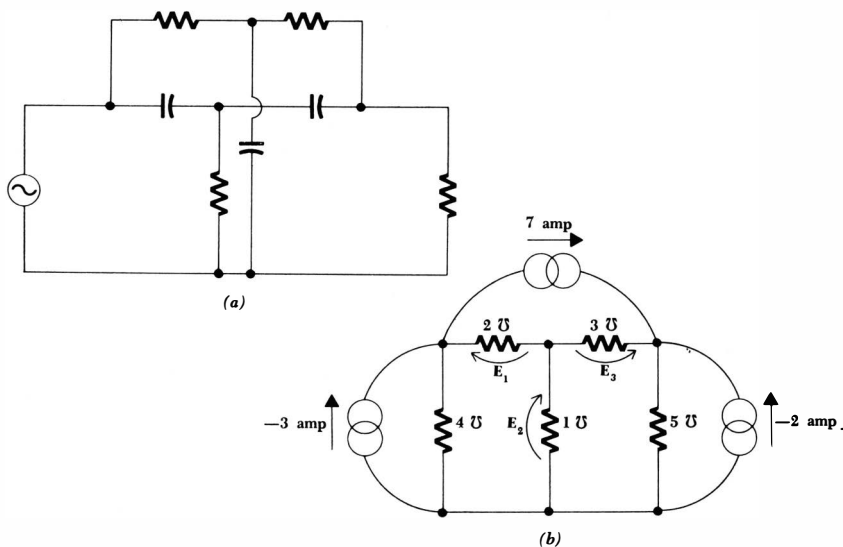
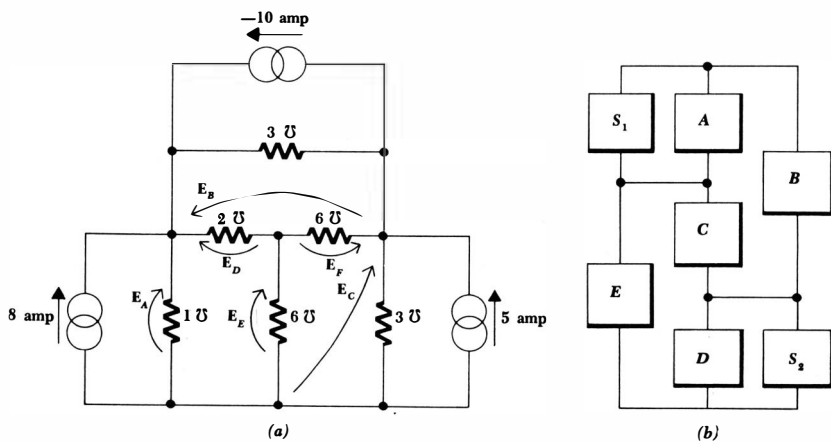

Fig. 18-19 (a) See Prob. 6. (b) See Prob. 7.

Fig. 18-20 (a) See Prob. 8. (b) See Prob. 9.



source currents and the current through C are equal to loop currents. (e) Draw a tree so that both source currents and the current through both C and D are equal to loop currents.

- *10 For the network shown in Fig. 18-21a: (a) How many loop equations must be written? (b) How many nodal equations must be written if the general voltage-source branch is changed to a general current source? (c) For the circuit as shown, which of the “trees” shown in Fig. 18-21b, c, d, e, f, and g are correct trees?

Fig. 18-21 See Prob. 10.

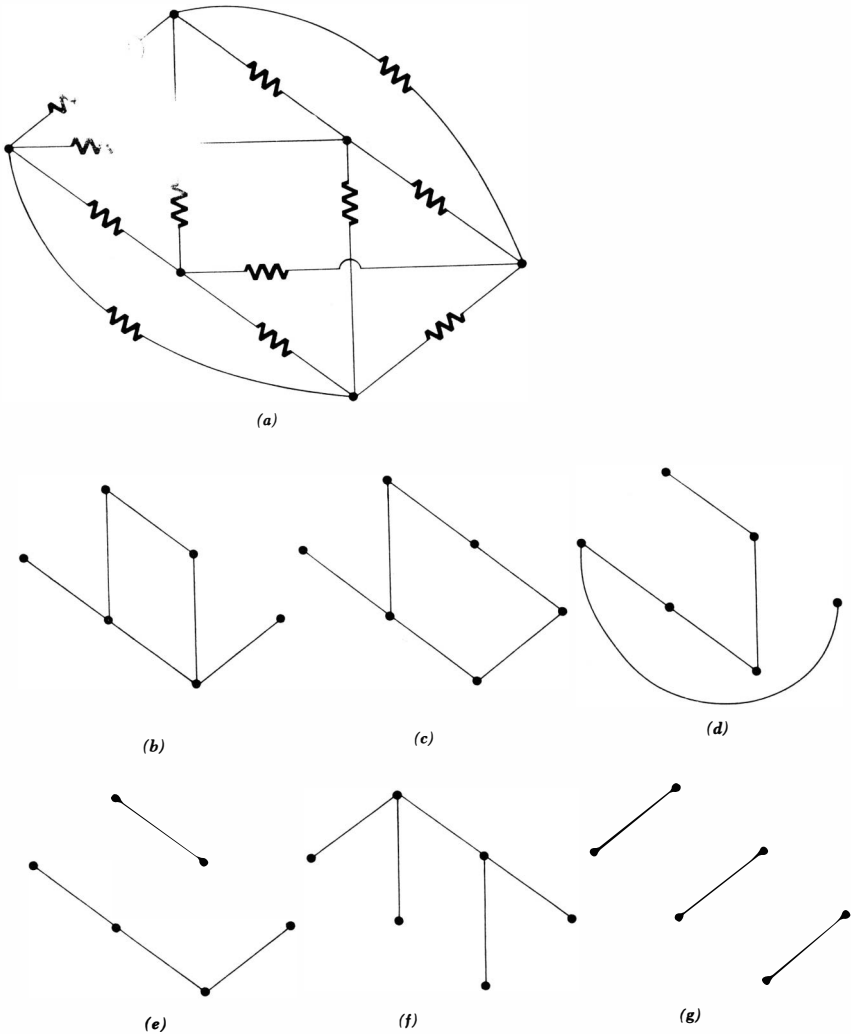

- 11 Assume that each source in the circuit shown in Fig. 18-22 is an ideal voltage source in series with an impedance. How many mesh or loop equations are required? If each source is assumed to be an ideal current source in parallel with an admittance, how many nodal equations are required?
- ◆12 Find the current in every branch in the circuit shown in Fig. 18-23.

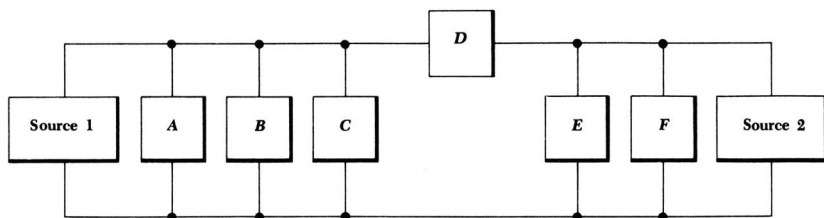

Fig. 18-22 See Prob. 11.

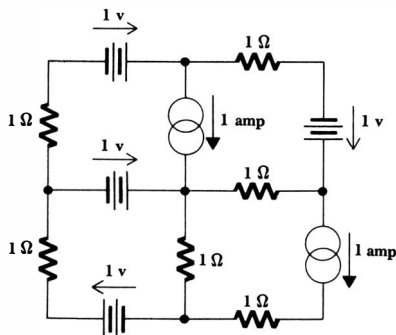
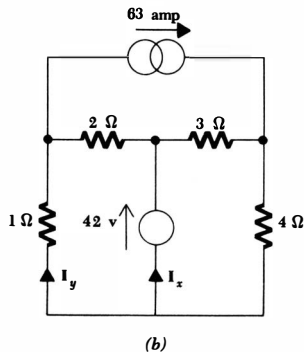
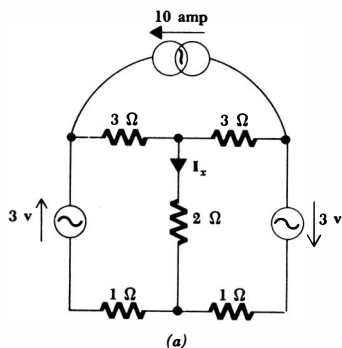

Fig. 18-23 See Prob. 12.

Fig. 18-24 (a) See Prob. 13. (b) See Prob. 14.



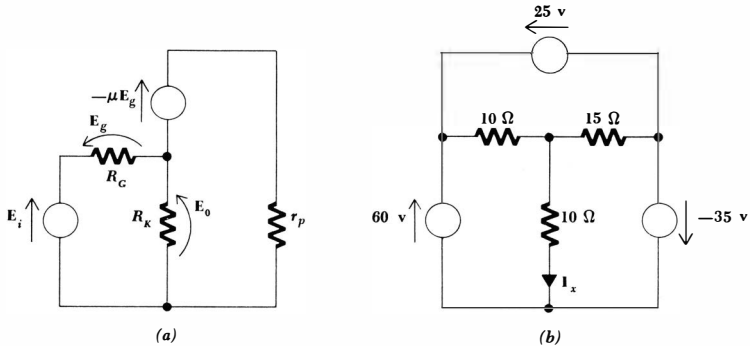

Fig. 18-25 (a) See Prob. 15. (b) See Prob. 16.

- 13 Find I_x in the circuit shown in Fig. 18-24a.
- ◆14 In the circuit of Fig. 18-24b select a tree which will allow the simplest set of loop equations to be written which involve I_x and I_y . Write the necessary loop equations and determine both I_x and I_y .
- 15 The circuit of Fig. 18-25a includes a dependent voltage source. Determine the ratio of E_o/E_i for this equivalent circuit of a cathode follower.
- 16 Find I_x in the circuit of Fig. 18-25b by writing only two loop equations. Why is this possible?
- ◆17 Interchange the 10-volt source and the upper-right 2-ohm resistor in the circuit of Fig. 18-16 and find E_1 by writing loop equations. The 10-volt source sense arrow is to be directed down and to the right.
- 18 Rework Prob. 17 by writing nodal equations. Difficulties should be expected, but ingenuity always triumphs.

Chapter 19 Polyphase Circuits

19-1 INTRODUCTION

One of the reasons for studying the sinusoidal steady state is that most household and industrial electric power is utilized as alternating current. The sinusoidal waveform may characterize a special mathematical function, but it represents a very common and very useful forcing function. A *polyphase* source is even more specialized, but we again consider it because almost the entire output of the electric power industry in this country is generated and distributed as polyphase power at a 60-cps frequency. Before defining our terms carefully, let us look briefly at the most common polyphase system, a balanced three-phase system. The source has perhaps three terminals, and voltmeter measurements will show that sinusoidal voltages of equal magnitude are present between any two terminals. However, these voltages are not in phase; it will be easily shown later that each of the three voltages is 120° out of phase with each of the other two, the sign of the phase angle depending on the sense of the voltages. A balanced load draws power equally from the three phases, but when one of the voltages is instantaneously zero, the phase relationship shows that the other two must each be at half amplitude. At no instant does the instantaneous power drawn by the total load reach zero; as a matter of fact, this total instantaneous power is constant. This is an advantage in rotating machinery, for it keeps the torque much more constant than it would be if a single-phase source were used. There is less vibration.

There are also advantages in using rotating machinery to generate three-phase power rather than single-phase power, and there are economical advantages in favor of the transmission of power in a three-phase system. We shall consider this last point in a problem later.

A larger number of phases will produce less vibration, but the reduction is usually not worth the added complexity. The use of a higher number of phases,

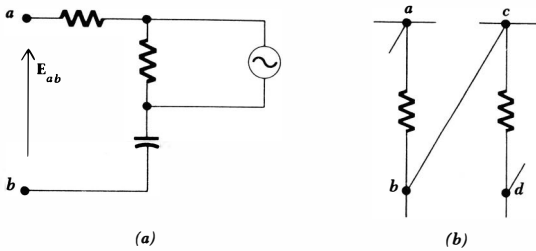

Fig. 19-1 (a) The definition of the voltage E_{ab} . (b) A network used to illustrate the application of the double-subscript notation for voltages.

such as in 6- and 12-phase systems, is limited almost entirely to the supply of power to large rectifiers. Here, the rectifiers convert the alternating current to direct current, which is required for certain processes such as electrolysis. The rectifier output is a pulsating direct current, and the amplitude of the undesirable pulsations, or ripple, decreases as the number of phases increases.

Two-phase systems have many applications in the field of automatic control. One of the phases of a two-phase motor may be automatically controlled in amplitude and polarity in order to provide a torque in either direction, as well as zero torque.

Almost without exception, polyphase systems in practice will contain sources which may be closely approximated by ideal voltage sources or by ideal voltage sources in series with small internal impedances. The methods which we shall study will therefore be based upon voltage sources and mesh or loop analysis; three-phase current sources are extremely rare.

It is convenient to describe polyphase voltages and currents using a double-subscript notation. With this notation, a voltage or current, such as E_{ab} or I_{aA} , has more meaning than if it were indicated simply as E_3 or I_x . By definition, let the voltage of point a with respect to point b be E_{ab} . Thus, the arrowhead is located at a , as indicated in Fig. 19-1a. With reference to Fig. 19-1b, it is now obvious that $E_{ad} = E_{ab} + E_{cd}$. The power of the double-subscript notation lies in the fact that Kirchhoff's voltage law requires the voltage between two points to be the same, regardless of the path chosen between the points, and thus $E_{ad} = E_{ab} + E_{bd} = E_{ac} + E_{cd} = E_{ab} + E_{bc} + E_{cd}$, etc. It is apparent that Kirchhoff's voltage law may be satisfied without reference to the circuit diagram; correct equations may be written even though a point, or subscript letter, is included which is not marked on the diagram. For example, we might also have written, above, $E_{ad} = E_{ax} + E_{xd}$.

One possible representation of a three-phase system of voltages¹ will be found to be that of Fig. 19-2. Let us assume that the voltages E_{an} , E_{bn} , and E_{cn} are known,

$$E_{an} = 100/0^\circ \text{ volts rms}$$

$$E_{bn} = 100/-120^\circ$$

$$E_{cn} = 100/-240^\circ$$

¹ Rms values of currents and voltages will be used throughout this chapter.

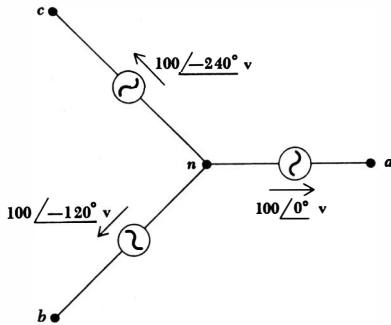

Fig. 19-2 A network used as a numerical example of double-subscript voltage notation.

and thus the voltage E_{ab} may be found, with an eye on the subscripts,

$$\begin{aligned}
 E_{ab} &= E_{an} + E_{nb} = E_{an} - E_{bn} \\
 &= 100\angle 0^\circ - 100\angle -120^\circ \\
 &= 100 - (-50 - j86.6) \\
 &= 173.2\angle 30^\circ
 \end{aligned}$$

The three given voltages and the construction of the phasor E_{ab} are shown on the phasor diagram of Fig. 19-3.

A double-subscript notation may also be applied to currents. We define the current I_{ab} as the current flowing from a to b by the direct path. In every complete circuit we consider, there must of course be at least two possible paths between the points a and b , and we agree that we shall not use double-subscript notation unless it is obvious that one path is much shorter, or much more direct. Usually this path is through a single element. Thus, the current I_{ab} is correctly indicated in Fig. 19-4, but the mere identification of a current as I_{cd} would cause confusion.

Before considering polyphase systems, we shall make use of double-subscript notation to help with the analysis of a special single-phase system.

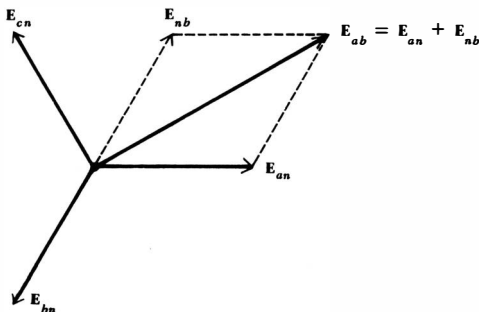

Fig. 19-3 A phasor diagram illustrating the graphical use of the double-subscript voltage convention to obtain E_{ab} for the network of Fig. 19-2.

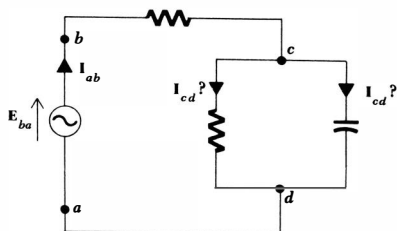

Fig. 19-4 An illustration of the use and misuse of the double-subscript convention for current notation.

Drill Problems

19-1 If $E_{ab} = 100/0^\circ$, $E_{bc} = 50/90^\circ$, and $E_{ac} = 100/45^\circ$, find (a) E_{bd} ; (b) E_{ac} ; (c) E_{ad} .

Ans. $111.8/26.6^\circ$ volts; $35.9/-35.2^\circ$ volts; $73.7/-163.7^\circ$ volts

19-2 If E_{xy} is $200/0^\circ$ volts in the circuit shown in Fig. 19-5, find: (a) I_{ad} ; (b) I_{za} ; (c) I_{zz} .

Ans. $3.29/80.6^\circ$ amp; $3.29/80.6^\circ$ amp; $7.35/17.1^\circ$ amp

19-2 SINGLE-PHASE THREE-WIRE SYSTEMS

A single-phase three-wire source is defined as a source having three output terminals, such as a , n , and b in Fig. 19-6a, at which the phasor voltages E_{an} and E_{nb} are equal. The source may therefore be represented by the combination of two identical voltage sources; in Fig. 19-6b, $E_{an} = E_{nb} = E_1$. It is apparent that $E_{ab} = 2E_{an} = 2E_{nb}$, and we therefore have a source to which loads operating at either of two voltages may be connected. The normal household system is single-phase three-wire, permitting the operation of both 115-volt and 230-volt appliances. The higher-voltage appliances are normally those drawing a larger power, and thus they cause a current in the lines which is only half that which operation at the same power and half the voltage would produce. Smaller-diameter wire may consequently be used safely in the appliance, the household distribution system, and the distribution system of the utility company.

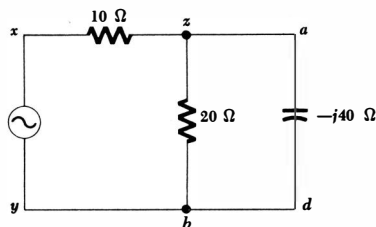
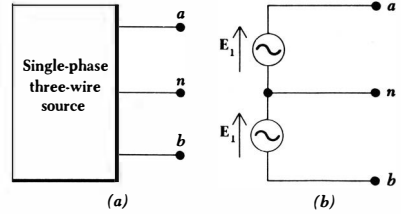

Fig. 19-5 See Drill Prob. 19-2.

Fig. 19-6 (a) A single-phase three-wire source. (b) The representation of a single-phase three-wire source by two identical voltage sources.



The name single phase arises because the voltages E_{an} and E_{nb} , being equal, must have the same phase angle. From another viewpoint, however, the voltages between the outer wires and the central wire, which is usually referred to as the *neutral*, are exactly 180° out of phase. That is, $E_{an} = -E_{bn}$ and $E_{an} + E_{bn} = 0$. In a following section we shall see that balanced polyphase systems are characterized by possessing a set of voltages of equal *magnitude* whose (phasor) sum is zero. From this viewpoint, then, the single-phase three-wire system is really a balanced two-phase system. “Two phase,” however, is a term that is traditionally reserved for something quite different, as we shall see in the following section.

Let us now consider a single-phase three-wire system which contains identical loads Z_p between each outer wire and the neutral (Fig 19-7). We shall first assume that the wires connecting the source to the load are perfect conductors. Since

$$E_{an} = E_{nb}$$

then,

$$I_{aA} = \frac{E_{an}}{Z_p} = I_{Bb} = \frac{E_{nb}}{Z_p}$$

and, therefore,

$$I_{nN} = I_{Bb} + I_{Aa} = I_{Bb} - I_{aA} = 0$$

Thus there is no current in the neutral wire, and it could be removed without changing any current or voltage in the system. This result is achieved through the equality of the two loads and of the two sources.

We next consider the effect of a finite impedance in each of the wires. If lines aA and bB each have the same impedance, this impedance may be added to Z_p , resulting in two equal loads once more and zero neutral current. Now let

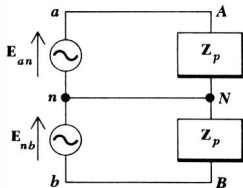

Fig. 19-7 A simple single-phase three-wire system. The two loads are identical and the neutral current is zero.

us allow the neutral wire to possess some impedance Z_n . Without carrying out any detailed analysis, superposition should show us that the symmetry of the circuit will still cause zero neutral current. Moreover, the addition of any impedance connected directly from one of the outer lines to the other outer line also yields a symmetrical circuit and zero neutral current. Thus, zero neutral current is a consequence of a balanced, or symmetrical, load; any impedance in the neutral wire does not destroy the symmetry.

The most general single-phase three-wire system will contain unequal loads between each outside line and the neutral and another load directly between the two outer lines; the impedances of the two outer lines may be expected to be approximately equal, but the neutral impedance may be slightly larger. An example of such a system is shown in Fig. 19-8. The analysis of the circuit is most easily achieved by assigning mesh currents and writing the appropriate equations. The results of this labor are

$$\mathbf{I}_1 = 11.2 / -19.8^\circ$$

$$\mathbf{I}_2 = 9.38 / -24.5^\circ$$

$$\mathbf{I}_3 = 10.4 / -21.8^\circ$$

The currents in the outer lines are thus

$$\mathbf{I}_{aA} = \mathbf{I}_1 = 11.2 / -19.8^\circ$$

$$\mathbf{I}_{bB} = -\mathbf{I}_3 = 10.4 / 158.2^\circ$$

and the smaller neutral current is

$$\mathbf{I}_{nN} = \mathbf{I}_3 - \mathbf{I}_1 = 0.95 / -177.9^\circ$$

The power drawn by each load may be determined,

$$P_{50} = |\mathbf{I}_1 - \mathbf{I}_2|^2 (50) = 207 \text{ watts}$$

which could represent two 100-watt lamps in parallel,

$$P_{100} = |\mathbf{I}_3 - \mathbf{I}_2|^2 (100) = 117 \text{ watts}$$

which might represent one 100-watt lamp,

$$P_{20 + j10} = |\mathbf{I}_2|^2 (20) = 1763 \text{ watts}$$

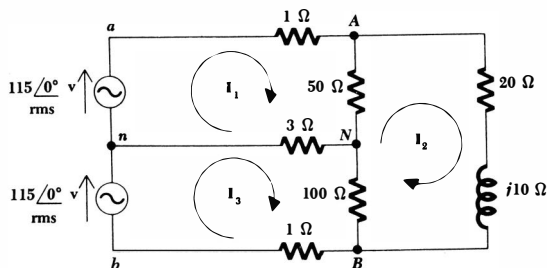

Fig. 19-8 A typical single-phase three-wire system.

which we may think of as a 2-hp induction motor. The total load power is 2087 watts. The loss in each of the wires is next found:

$$P_{aA} = |I_1|^2 (1) = 126 \text{ watts}$$

$$P_{bB} = |I_3|^2 (1) = 108 \text{ watts}$$

$$P_{nN} = |I_{nN}|^2 (3) = 2.7 \text{ watts}$$

or a total line loss of 237 watts. The wires are evidently quite long; otherwise, the relatively high power loss in the two outer lines would cause a dangerous temperature rise. The total generated power must therefore be 2324 watts, and this may be checked by finding the power delivered by each voltage source:

$$P_{an} = 115 (11.2) \cos 19.8^\circ = 1218 \text{ watts}$$

$$P_{bn} = 115 (10.4) \cos 21.8^\circ = 1108 \text{ watts}$$

or a total of 2326 watts. The transmission efficiency for this system is

$$\text{Eff.} = \frac{2087}{2087 + 237} = 89.8\%$$

This value would be unbelievable for a steam engine or an internal-combustion engine, but it is too low for a well-designed distribution system. Larger-diameter wires should be used if the source and the load cannot be placed closer to each other.

A phasor diagram showing the two source voltages, the currents in the outer lines, and the current in the neutral is constructed in Fig. 19-9. The fact that $I_{aA} + I_{bB} + I_{nN} = 0$ is indicated on the diagram.

Drill Problem

19-3 In the circuit of Fig. 19-8, replace the $20 + j10$ ohm load by a pure resistance of 40 ohms. (a) Find the power drawn by the 40-ohm load. (b) Assume that the 50-ohm load is a light bulb which burns out. What power is now taken by the 40-ohm load? (c) The 50-ohm (200-watt) bulb is replaced by a good bulb, and then the 100-ohm load burns out. Now what power is delivered to the 40-ohm load?

Ans. 1179 watts; 1189 watts; 1166 watts

19-3 TWO-PHASE THREE-WIRE SYSTEMS

Two-phase systems do not have nearly the practical importance of either single-phase or three-phase systems, and we shall content ourselves with a definition and an inspection of the relative magnitudes and phases of the voltages and currents in a balanced system.

Let us define a two-phase three-wire source as a source having terminals a , n , and b , at which $E_{bn} = \pm jE_{an}$. The source may therefore be represented by again connecting two ideal voltage sources, as shown in Fig. 19-10a. To this source we

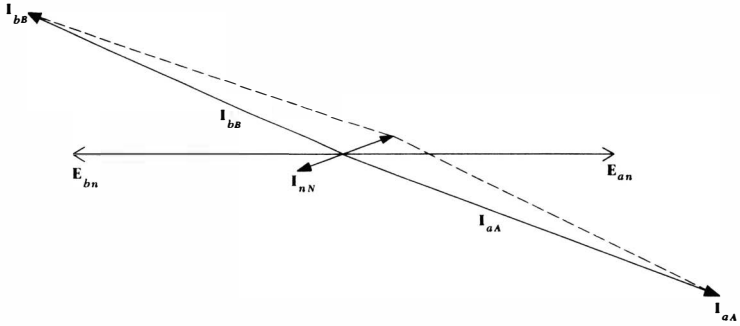

Fig. 19-9 The source voltages and three of the currents in the circuit of Fig. 19-8 are shown on a phasor diagram.

shall connect a balanced load, consisting of equal impedances Z_p from each outside line to the neutral. Let us assume arbitrarily that E_{bn} leads E_{an} by 90° . Thus,

$$E_{bn} = j E_{an}$$

and the voltage between the outside lines is

$$\begin{aligned} E_{ab} &= E_{an} + E_{nb} \\ &= E_{an} - j E_{an} \\ &= \sqrt{2} E_{an} \angle -45^\circ \end{aligned}$$

The outer line currents are equal in magnitude and 90° out of phase,

$$I_{aA} = \frac{E_{ab}}{Z_p}$$

$$I_{bB} = \frac{E_{bn}}{Z_p} = j I_{aA}$$

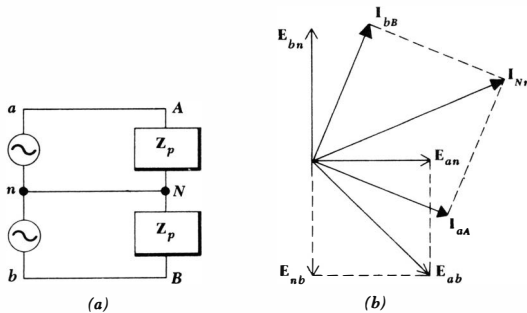

Fig. 19-10 (a) A two-phase three-wire system. (b) The phasor diagram for this two-phase system.

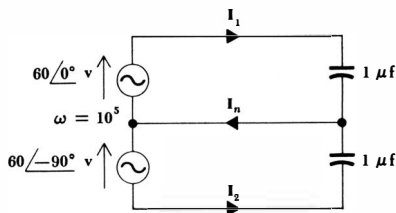

Fig. 19-11 See Drill Prob. 19-4.

and the neutral current is larger than either,

$$\begin{aligned} \mathbf{I}_{nN} &= -\mathbf{I}_{aA} - \mathbf{I}_{bB} \\ &= -(1 + j1)\mathbf{I}_{aA} \\ &= -\sqrt{2}\mathbf{I}_{aA}/45^\circ \end{aligned}$$

A phasor diagram for this two-phase system is shown in Fig. 19-10*b*; a load with a lagging power factor is assumed.

The greatest use of two-phase systems is in the control of small motors. In this application, the two voltages are unequal. Two-phase four-wire systems, in which there is no electrical connection between the two phases, are also seen in practice.

Drill Problem

19-4 Find the ratios $|\mathbf{I}_1/\mathbf{I}_2|$ and $|\mathbf{I}_1/\mathbf{I}_n|$ for: (a) the balanced two-phase circuit of Fig. 19-11; (b) this circuit if each of the two outer lines has a resistance of 5 ohms; (c) this circuit if each of the three wires has a resistance of 5 ohms.

Ans. 1, 0.707; 1.612, 1.140; 1, 0.707

19-4 THREE-PHASE Y-Y CONNECTION

Three-phase sources have three terminals, called the *line* terminals, and they may or may not have a fourth terminal, the *neutral* connection. We shall begin by discussing a three-phase source which does have a neutral connection. It may be represented by three ideal voltage sources connected in a Y, as shown in Fig. 19-12; terminals *a*, *b*, *c*, and *n* are available. We shall consider only balanced three-phase sources which may be defined as having

$$|\mathbf{E}_{an}| = |\mathbf{E}_{bn}| = |\mathbf{E}_{cn}|$$

and $\mathbf{E}_{an} + \mathbf{E}_{bn} + \mathbf{E}_{cn} = 0$

These three voltages, each existing between one line and the neutral, are called *phase voltages*. If we arbitrarily choose \mathbf{E}_{an} as the reference,

$$\mathbf{E}_{an} = E_p/0^\circ$$

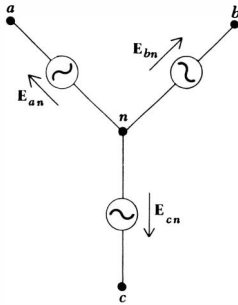

Fig. 19-12 A Y-connected three-phase source.

where we shall consistently use E_p to represent the magnitude of any of the phase voltages, then the definition of the three-phase source indicates that either

$$\mathbf{E}_{bn} = E_p / -120^\circ \quad \mathbf{E}_{cn} = E_p / -240^\circ$$

or
$$\mathbf{E}_{bn} = E_p / 120^\circ \quad \mathbf{E}_{cn} = E_p / 240^\circ$$

The former is called *positive phase sequence*, or *abc* phase sequence, and is shown in Fig. 19-13a; the latter is termed *negative phase sequence*, or *cba* phase sequence, and is indicated by the phasor diagram of Fig. 19-13b. It is apparent that the phase sequence of a physical three-phase source depends on the arbitrary choice of the three terminals to be lettered *a*, *b*, and *c*. They may always be chosen to provide positive phase sequence, and we shall assume that this has been done in most of the systems we consider.

Let us next find the line-to-line voltages (or simply “line” voltages) which are present when the phase voltages are those of Fig. 19-13a. It is easiest to do this with the help of a phasor diagram, since the angles are all multiples of 30° . The

Fig. 19-13 (a) Positive, or *abc*, phase sequence. (b) Negative, or *cba*, phase sequence.

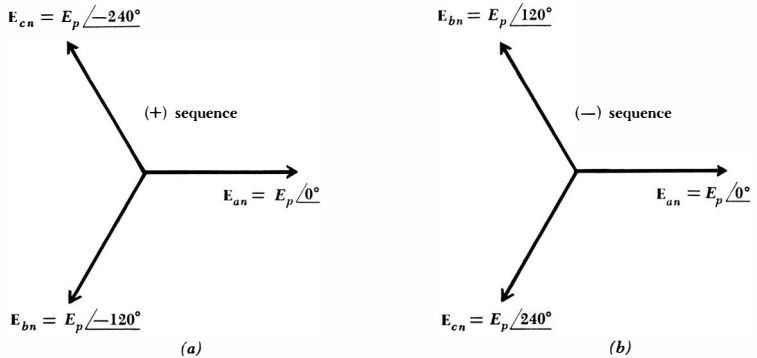

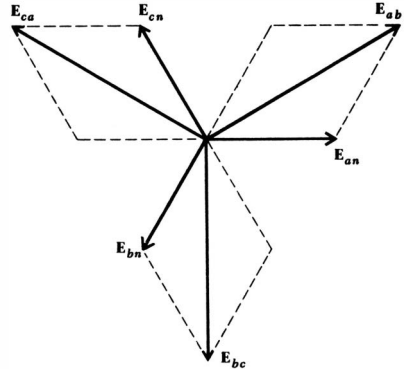

Fig. 19-14 A phasor diagram which is used to determine the line voltages from the given phase voltages.

necessary construction is shown in Fig. 19-14; the results are

$$E_{ab} = \sqrt{3} E_p / 30^\circ \quad E_{bc} = \sqrt{3} E_p / -90^\circ \quad E_{ca} = \sqrt{3} E_p / -210^\circ$$

Kirchhoff's voltage law requires the sum of these three voltages to be zero, and it is zero.

Denoting the magnitude of any of the line voltages by E_L , then one of the important characteristics of the Y-connected three-phase source may be expressed as

$$E_L = \sqrt{3} E_p$$

Note that, with positive phase sequence, E_{an} leads E_{bn} and E_{bn} leads E_{cn} , in each case by 120° , and also that E_{ab} leads E_{bc} and E_{bc} leads E_{ca} , again by 120° . The statement is true for negative sequence if "lags" is substituted for "leads."

Now let us connect a balanced Y-connected three-phase load to our source, using three lines and a neutral, as drawn in Fig. 19-15. The load is represented by an impedance Z_p between each line and the neutral. The three line currents are found very easily, since we really have three single-phase circuits which possess one common lead:

$$I_{aA} = \frac{E_{an}}{Z_p}$$

$$I_{bB} = \frac{E_{bn}}{Z_p} = \frac{E_{an} / -120^\circ}{Z_p} = I_{aA} / -120^\circ$$

$$I_{cC} = I_{aA} / -240^\circ$$

and thus

$$I_{Nn} = I_{aA} + I_{bB} + I_{cC} = 0$$

Thus, the neutral carries no current if the source and load are both balanced and if the four wires have zero impedance. How will this change if an impedance Z_L is inserted in series with each of the three lines and an impedance

Z_n is inserted in the neutral? Evidently, the line impedances may be combined with the three load impedances; this effective load is still balanced, and a perfectly conducting neutral wire could be removed. Thus, if no change is produced in the system with a short circuit or an open circuit between n and N , any impedance may be inserted in the neutral and the neutral current will remain zero.

It follows that, if we have balanced sources, balanced loads, and balanced line impedances, a neutral wire of any impedance may be replaced by any other impedance, including a short circuit and an open circuit. It is often helpful to visualize a short circuit between the two neutral points; the problem is then reduced to three single-phase problems, all identical. We say that we thus work the problem on a "per-phase" basis.

Let us work several problems involving a balanced three-phase system having a Y-Y connection. A straightforward problem is suggested by the circuit of Fig. 19-16; we are asked to find the several currents and voltages throughout the circuit and to find the total power.

Since one of the source phase voltages is given, and since positive phase sequence is assumed, the three phase voltages are

$$E_{an} = 200/0^\circ \quad E_{bn} = 200/-120^\circ \quad E_{cn} = 200/-240^\circ$$

The line voltage is $200\sqrt{3}$, or 346 volts; the phase angle of each line voltage can be determined by constructing a phasor diagram, as before. As a matter of fact, the phasor diagram of Fig. 19-14 is applicable, and E_{ab} is $346/30^\circ$ volts.

Let us work with phase A . The line current is

$$I_{aA} = \frac{E_{an}}{Z_p} = \frac{200/0^\circ}{100/60^\circ} = 2/-60^\circ$$

and the power absorbed by this phase is, therefore,

$$P_{AN} = 200(2) \cos(0^\circ + 60^\circ) = 200 \text{ watts}$$

Thus, the total power drawn by the three-phase load is 600 watts. The problem is completed by drawing a phasor diagram and reading from it the appropriate phase angles which apply to the other line voltages and currents. The completed diagram is shown in Fig. 19-17.

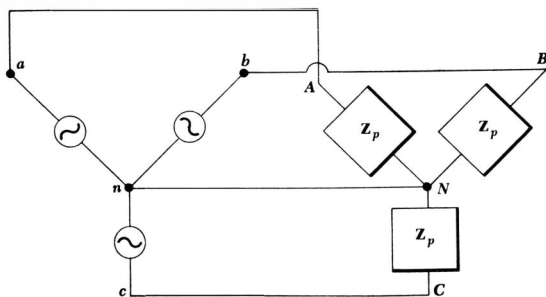

Fig. 19-15 A balanced three-phase system, connected Y-Y, and including a neutral.

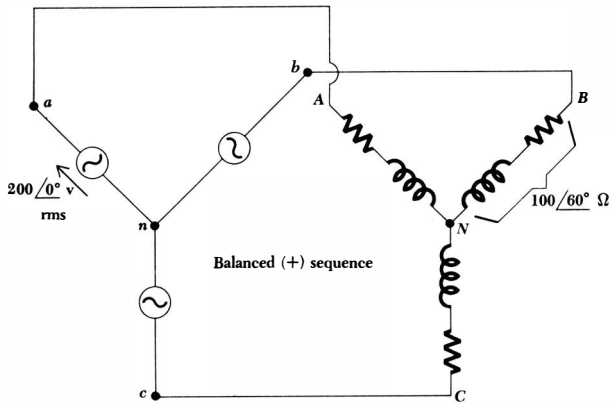

Fig. 19-16 A balanced three-phase three-wire Y-Y connected system used as a numerical example.

We may also use per-phase methods to work problems in what might be called the backward direction. Suppose that we have a balanced three-phase system with an rms line voltage of 300 volts, and we know that it is supplying a balanced Y-connected load with 1200 watts at a leading power factor of 0.8. What is the line current and the per-phase load impedance? It is evident that the phase voltage is $300/\sqrt{3}$ volts and the per-phase power is 400 watts. Thus the line current may be found from the power relationship

$$400 = \frac{300}{\sqrt{3}} (I_L)(0.8)$$

and the line current is therefore 2.89 amp. The phase impedance is given by

$$|Z_p| = \frac{E_p}{I_L} = \frac{300/\sqrt{3}}{2.89} = 60 \text{ ohms}$$

Since the power factor is 0.8, leading, the impedance phase angle is -36.8° , and $Z_p = 60\angle-36.8^\circ$.

More complicated loads can be easily handled, since the problems reduce to simpler single-phase problems. Suppose that a balanced 600-watt lighting load is added to the system above. A suitable per-phase circuit is first sketched, as shown in Fig. 19-18.

The magnitude of the lighting current is determined by

$$200 = \frac{300}{\sqrt{3}} |I_1| \cos 0^\circ$$

and $|I_1| = 1.155$

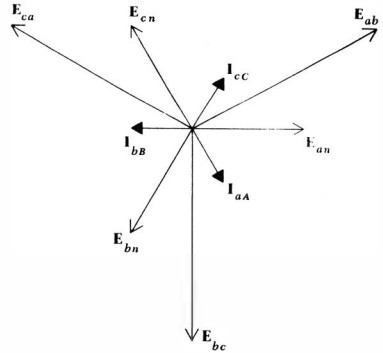

Fig. 19-17 The phasor diagram which is applicable to the circuit of Fig. 19-16.

In a similar way, the magnitude of the capacitive load current is found to be unchanged from its previous value,

$$|I_2| = 2.89$$

If we assume that the phase with which we are working has a phase voltage with an angle of 0° , then

$$I_1 = 1.155 \angle 0^\circ \quad I_2 = 2.89 \angle -36.8^\circ$$

and the line current is

$$I_L = I_1 + I_2 = 3.87 \angle -26.6^\circ \text{ amp}$$

The power generated by this phase of the source is, therefore,

$$P_p = \frac{300}{\sqrt{3}} 3.87 \cos(-26.6^\circ) = 600 \text{ watts}$$

which checks with the original hypothesis.

If an *unbalanced* Y-connected load is present in an otherwise balanced three-phase system, the circuit may still be analyzed on a per-phase basis *if* the neutral wire is present and *if* it has zero impedance. If either of these conditions is not met, other methods must be used. An engineer who spends most of his time with unbalanced three-phase systems will find the use of *symmetrical components* a great timesaver. We shall not discuss this method here.

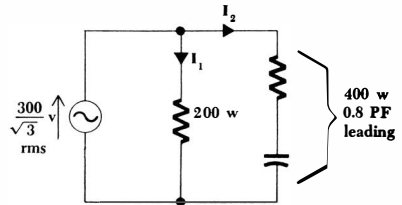

Fig. 19-18 The per-phase circuit which is used to solve a balanced three-phase example.

Drill Problems

19-5 Assume a balanced three-phase three-wire system with a Y-connected load. If $\mathbf{E}_{an} = 10\angle 20^\circ$ volts, the impedance in each phase is $5\angle -25^\circ$ ohms, and positive phase sequence is assumed, find: (a) \mathbf{E}_{bn} ; (b) \mathbf{E}_{ab} ; (c) \mathbf{E}_{cb} .

Ans. $17.32\angle 110^\circ$ volts; $17.32\angle 50^\circ$ volts; $10\angle -100^\circ$ volts

19-6 For the circuit described in Drill Prob. 19-5, find: (a) \mathbf{I}_{aA} ; (b) \mathbf{I}_{bB} ; (c) \mathbf{I}_{cC} .

Ans. $2\angle 45^\circ$ amp; $2\angle -15^\circ$ amp; $2\angle -75^\circ$ amp

19-7 A 440-volt (line-voltage) three-phase three-wire system feeds two balanced Y-connected loads. For one load, $\mathbf{Z}_{p1} = 10 - j5$ ohms, and for the other, $\mathbf{Z}_{p2} = 20 + j5$ ohms. Find the magnitude of the current: (a) in any \mathbf{Z}_{p1} ; (b) in any \mathbf{Z}_{p2} ; (c) in any line.

Ans. 22.7 amp; 33.0 amp; 12.3 amp

19-8 A three-wire three-phase system has a line voltage of 346.4 volts. It supplies a 3-kw lighting load. (a) Find the line current (magnitude). (b) An additional load of 4 kw at 0.8 power factor lagging is connected. Find the new line current. (c) A synchronous machine is also added to the above system. It is operated in such a way that it draws no real power, but acts as a pure reactance. If it is adjusted to draw a total reactive power of -3 kvar, find the line current.

Ans. 12.7 amp; 5.00 amp; 11.67 amp

19-5 THE DELTA (Δ) CONNECTION

A three-phase load is more apt to be found Δ -connected than Y-connected. One reason for this, at least for the case of an unbalanced load, is the flexibility with which loads may be added or removed on a single phase. This is difficult (or impossible) to do with a Y-connected three-wire load.

Let us consider a balanced Δ -connected load which consists of an impedance \mathbf{Z}_p inserted between each pair of lines. We shall assume a three-wire system for obvious reasons. With reference to Fig. 19-19, let us assume known line voltages

$$E_L = |\mathbf{E}_{ab}| = |\mathbf{E}_{bc}| = |\mathbf{E}_{ca}|$$

or known phase voltages

$$E_p = |\mathbf{E}_{an}| = |\mathbf{E}_{bn}| = |\mathbf{E}_{cn}|$$

where $E_L = \sqrt{3} E_p$ and $\mathbf{E}_{ab} = \sqrt{3} \mathbf{E}_{an} \angle 30^\circ$

and so forth, as before. Since the voltage across each branch of the Δ is known, the *phase currents* are found,

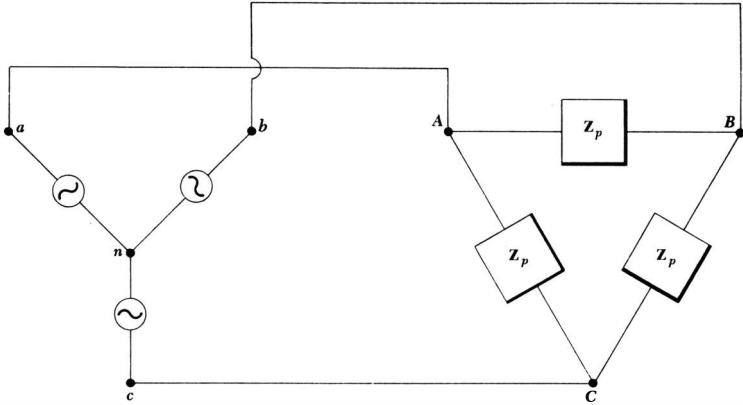

Fig. 19-19 A balanced Δ -connected load is present on a three-wire three-phase system. The source happens to be Y-connected.

$$I_{AB} = \frac{E_{ab}}{Z_p} \quad I_{BC} = \frac{E_{bc}}{Z_p} \quad I_{CA} = \frac{E_{ca}}{Z_p}$$

and their differences provide us with the line currents, such as

$$I_{aA} = I_{AB} - I_{CA}$$

The three phase currents are of equal magnitude,

$$I_p = |I_{AB}| = |I_{BC}| = |I_{CA}|$$

The line currents are also equal in magnitude. This is due to having phase currents which are equal in magnitude and necessarily 120° out of phase. The symmetry is apparent from the phasor diagram of Fig. 19-20. We thus have

$$I_L = |I_{aA}| = |I_{bB}| = |I_{cC}|$$

and $I_L = \sqrt{3} I_p$

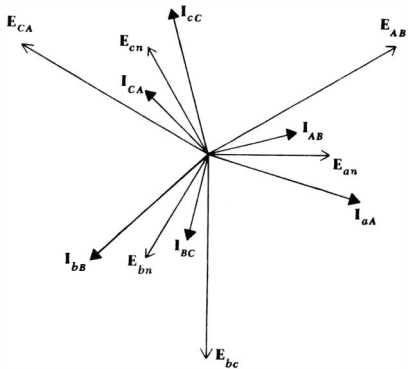

Fig. 19-20 A phasor diagram which might apply to the circuit of Fig. 19-19.

Let us disregard the source for the moment and consider only the balanced load. If the load is Δ -connected, then the phase voltage and the line voltage are indistinguishable, but the line current is larger than the phase current by a factor of $\sqrt{3}$; with a Y-connected load, however, the phase current and the line current refer to the same current, and the line voltage is greater than the phase voltage by a factor of $\sqrt{3}$.

The solution of three-phase problems will be speedily accomplished if the $\sqrt{3}$'s are used properly. Let us consider a typical numerical example. We are to determine the magnitude of the line current in a 300-volt 3-phase system which supplies 1200 watts to a Δ -connected load at a lagging power factor of 0.8. Let us again consider a single phase. It draws 400 watts, 0.8 lagging power factor, at a 300-volt line voltage. Thus,

$$400 = 300 (I_p)(0.8)$$

and $I_p = 1.667$ amp rms

and the relationship between phase currents and line currents yields

$$I_L = \sqrt{3} (1.667) = 2.89 \text{ amp rms}$$

Furthermore, the impedance in each phase must be

$$Z_p = \frac{300}{1.667} / \cos^{-1} 0.8 = 180 / 36.8^\circ \text{ ohms}$$

Now let us change the statement of the problem: the load is Y-connected instead of Δ -connected. On a per-phase basis, we now have a phase voltage of $300/\sqrt{3}$ volts, a power of 400 watts, and a lagging power factor of 0.8. Thus,

$$400 = \frac{300}{\sqrt{3}} (I_p)(0.8)$$

and $I_p = 2.89$ amp or $I_L = 2.89$ amp

The impedance in each phase of the Y is

$$Z_p = \frac{300/\sqrt{3}}{2.89} / \cos^{-1} 0.8 = 60 / 36.8^\circ$$

and it should be noted that the Y and Δ impedances are correctly related according to the Y- Δ transformation.

The $\sqrt{3}$ factor not only relates phase and line quantities but also appears in a useful expression for the total power drawn by any balanced three-phase load. If we assume a Y-connected load with a power-factor angle θ , then the power taken by any phase is

$$\begin{aligned} P_p &= E_p I_p \cos \theta \\ &= E_p I_L \cos \theta \\ &= \frac{E_L}{\sqrt{3}} I_L \cos \theta \end{aligned}$$

585 Polyphase Circuits

and the total power is

$$\begin{aligned} P &= 3P_p \\ &= \sqrt{3} E_L I_L \cos \theta \end{aligned}$$

In a similar way, the power delivered to each phase of a Δ -connected load is

$$\begin{aligned} P_p &= E_p I_p \cos \theta \\ &= E_L I_p \cos \theta \\ &= E_L \frac{I_L}{\sqrt{3}} \cos \theta \end{aligned}$$

or a total power

$$\begin{aligned} P &= 3P_p \\ \text{or } P &= \sqrt{3} E_L I_L \cos \theta \end{aligned} \quad (19-1)$$

Thus Eq. (19-1) enables us to calculate the total power delivered to a balanced load from a knowledge of the magnitude of the line voltage, of the line current, and of the phase angle of the load impedance (or admittance). The numerical example above can be worked in one line:

$$1200 = \sqrt{3} (300)(I_L)(0.8)$$

Therefore

$$I_L = \frac{5}{\sqrt{3}} = 2.89 \text{ amp rms}$$

The source may also be connected in Δ . This is not typical, however, for a slight unbalance in the source phases can lead to large currents circulating around the Δ loop. As an example, let us call the three single-phase sources \mathbf{E}_{ab} , \mathbf{E}_{bc} , and \mathbf{E}_{cd} . Before closing the Δ by connecting d to a , let us determine the unbalance by measuring the sum $\mathbf{E}_{ab} + \mathbf{E}_{bc} + \mathbf{E}_{cd}$. Suppose that the magnitude of the resultant is only 1 per cent of the line voltage. The circulating current is thus approximately $\frac{1}{3}$ per cent of the line voltage divided by the internal impedance of any source. How large is this impedance apt to be? It must depend on the current that the source is expected to deliver with a negligible drop in terminal voltage. If we assume that this maximum current causes a 1 per cent drop in the terminal voltage, then it is seen that the circulating current is one-third of the maximum current. This reduces the useful current capacity of the source and also increases the losses in the system.

Drill Problems

19-9 Assume a balanced three-phase three-wire system with a Δ -connected load. If $\mathbf{E}_{an} = 10/20^\circ$ volts, the impedance in each phase is $5/-25^\circ$ ohms, and positive phase sequence is assumed, find: (a) \mathbf{I}_{AB} ; (b) \mathbf{I}_{aA} ; (c) \mathbf{I}_{cC} .

Ans. $6/165^\circ$ amp; $6/45^\circ$ amp; $3.46/75^\circ$ amp

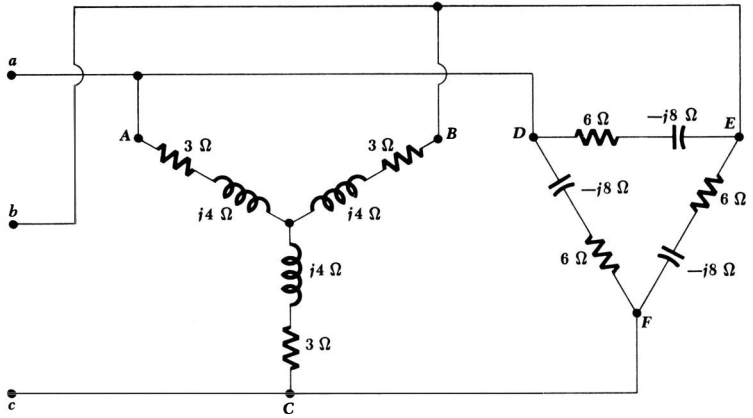

Fig. 19-21 See Drill Prob. 19-10.

19-10 For the three-phase three-wire system shown in Fig. 19-21, $E_{ab} = 200/0^\circ$ volts. Assume positive phase sequence again, and find: (a) I_{DE} ; (b) I_{AD} ; (c) I_{aA} .

Ans. $34.6/23.1^\circ$ amp; $20/53.1^\circ$ amp; $35.9/-15.2^\circ$ amp

19-6 POWER MEASUREMENT IN THREE-PHASE SYSTEMS

At first glance, the measurement of the power drawn by a three-phase load seems to be a simple problem. We need place only one wattmeter in each of the three phases and add the results. For example, the proper connections for a Y-connected load are shown in Fig. 19-22a. Each wattmeter has its current coil inserted in one phase of the load and its potential coil connected between the line side of that load and the neutral. In a similar way, three wattmeters may be connected as shown in Fig. 19-22b to measure the total power taken by a Δ -connected load. The methods are theoretically correct, but they may be useless in practice because the neutral of the Y is usually not accessible and the phases of the Δ are not available. A three-phase rotating machine, for example, has only three accessible terminals, those we have been calling *A*, *B*, and *C*.

It is obvious that we need a method for measuring the total power drawn by a three-phase load having only three accessible terminals; measurements may be made on the "line" side of these terminals, but not on the "load" side. Such a method is available, and it is capable of measuring the power taken by an *unbalanced* load from an *unbalanced* source. Let us connect three wattmeters in such a way that each has its current coil in one line and its voltage coil between that line and some common point *x*, as shown in Fig. 19-23. Although a system with a Y-connected load is illustrated, the arguments presented below are equally valid for a Δ -connected load. The point *x* may be some unspecified

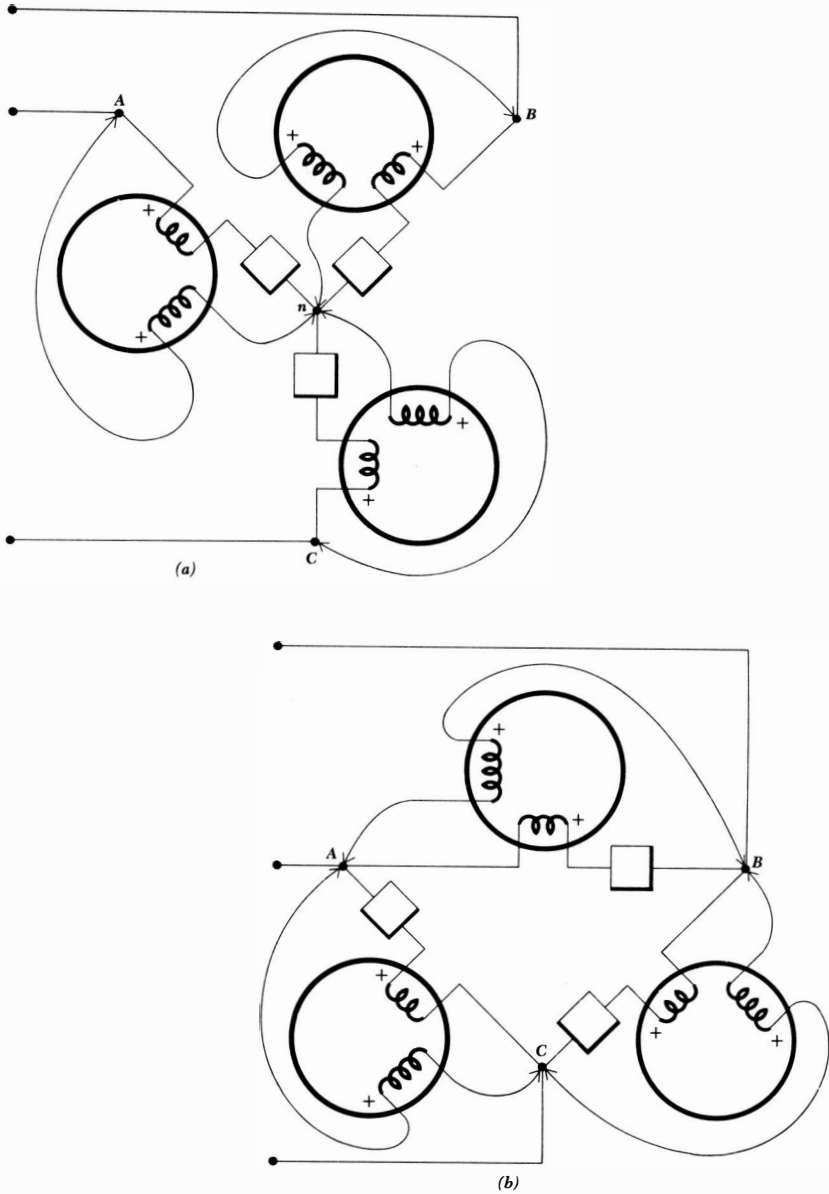

Fig. 19-22 Three wattmeters are connected in such a way that each reads the power taken by one phase of a three-phase load, and the sum of the readings is the total power. (a) A Y-connected load. (b) A Δ -connected load. Neither the loads nor the source need be balanced.

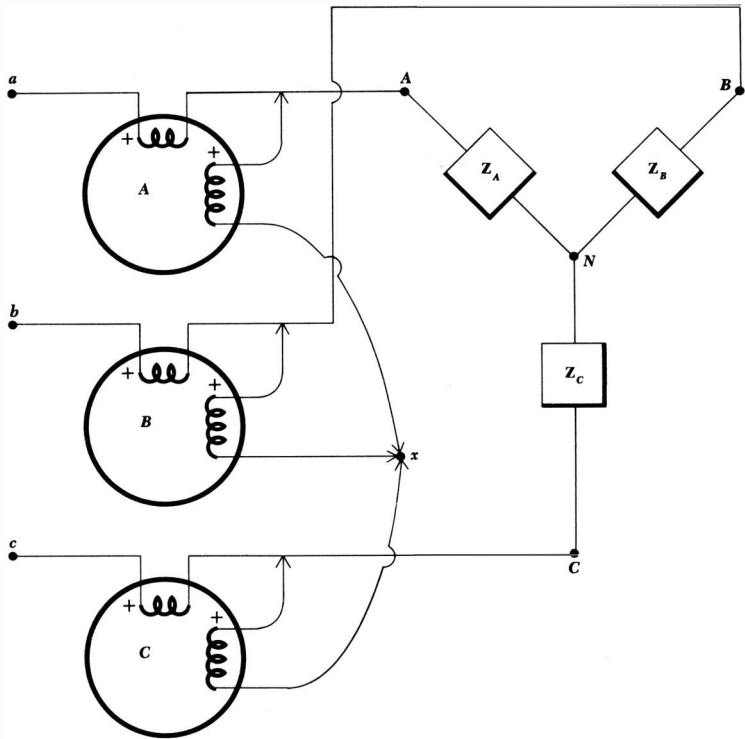

Fig. 19-23 A method of connecting three wattmeters to measure the total power taken by a three-phase load. Only the three terminals of the load need be available.

point in the three-phase system, or it may be merely a point in space at which the three potential coils have a common node. The average power indicated by wattmeter *A* must be

$$P_A = \frac{1}{T} \int_0^T e_{Ax} i_{aA} dt$$

where *T* is the period of all the source voltages. The readings of the other two wattmeters are given by similar expressions, and the total average power drawn by the load is therefore

$$P = P_A + P_B + P_C = \frac{1}{T} \int_0^T (e_{Ax} i_{aA} + e_{Bx} i_{bB} + e_{Cx} i_{cC}) dt$$

Each of the three voltages in the above expression may be written in terms of a phase voltage and the voltage between point *x* and the neutral,

$$e_{Ax} = e_{AN} + e_{Nx}$$

$$e_{Bx} = e_{BN} + e_{Nx}$$

$$e_{Cx} = e_{CN} + e_{Nx}$$

589 Polyphase Circuits

and, therefore,

$$P = \frac{1}{T} \int_0^T (e_{AN}i_{aA} + e_{BN}i_{bB} + e_{CN}i_{cC}) dt + \frac{1}{T} \int_0^T e_{Nx}(i_{aA} + i_{bB} + i_{cC}) dt$$

However, the entire three-phase load may be considered to be a supernode, and Kirchhoff's current law requires

$$i_{aA} + i_{bB} + i_{cC} = 0$$

Thus

$$P = \frac{1}{T} \int_0^T (e_{AN}i_{aA} + e_{BN}i_{bB} + e_{CN}i_{cC}) dt$$

Reference to the circuit diagram shows that this sum is indeed the sum of the average powers taken by each phase of the load, and the sum of the readings of the three wattmeters therefore represents the total average power drawn by the entire load.

Let us illustrate this procedure by a numerical example before we discover that one of these three wattmeters is really superfluous. We shall assume a balanced source,

$$E_{ab} = 100\angle 0^\circ \text{ volts rms}$$

$$E_{bc} = 100\angle -120^\circ$$

$$E_{ca} = 100\angle -240^\circ$$

or
$$E_{an} = \frac{100}{\sqrt{3}}\angle -30^\circ$$

$$E_{bn} = \frac{100}{\sqrt{3}}\angle -150^\circ$$

$$E_{cn} = \frac{100}{\sqrt{3}}\angle -270^\circ$$

and an unbalanced load,

$$Z_A = -j10$$

$$Z_B = j10$$

$$Z_C = 10$$

Let us assume ideal wattmeters, connected as illustrated in Fig. 19-23, with point x located on the neutral of the source n . The three line currents may be obtained by general mesh analysis,

$$I_{aA} = \frac{\begin{vmatrix} 100\angle 0^\circ & -j10 \\ 100\angle -120^\circ & 10 + j10 \end{vmatrix}}{\begin{vmatrix} 0 & -j10 \\ -j10 & 10 + j10 \end{vmatrix}} = 19.3\angle 15^\circ$$

and by similar methods,

$$I_{bB} = 19.3\angle 165^\circ \quad I_{cC} = 10\angle -90^\circ$$

The voltage between the neutrals is

$$\mathbf{E}_{nN} = \mathbf{E}_{nb} + \mathbf{E}_{BN} = \mathbf{E}_{nb} + \mathbf{I}_{bB}(j10) = 157.8/\underline{-90^\circ}$$

Thus, the average power indicated by each wattmeter may be calculated,

$$\begin{aligned} P_A &= E_p I_{aA} \cos(\text{ang } \mathbf{E}_{an} - \text{ang } \mathbf{I}_{aA}) \\ &= \frac{100}{\sqrt{3}} 19.3 \cos(15^\circ + 30^\circ) = 788 \text{ watts} \end{aligned}$$

$$P_B = \frac{100}{\sqrt{3}} 19.3 \cos(165^\circ + 150^\circ) = 788 \text{ watts}$$

$$P_C = \frac{100}{\sqrt{3}} 10 \cos(-90^\circ + 270^\circ) = -577 \text{ watts}$$

or a total power of 999 watts. Since an rms current of 10 amp flows through the resistive load, the total power drawn by the load is

$$P = 10^2(10) = 1000 \text{ watts}$$

and the three-wattmeter method checks within slide-rule accuracy.

It is interesting to note that the reading of one of the wattmeters is negative. The discussion of the use of the wattmeter in Chap. 12 indicates that an upscale reading on that meter can be obtained only after either the potential coil or the current coil is reversed.

We have proved that point x , the common connection of the three potential coils, may be located any place we wish without affecting the algebraic sum of the three wattmeter readings. Let us now consider the effect of placing point x , this common connection of the three wattmeters, directly on one of the lines. If, for example, one end of each potential coil is returned to B , then there is no voltage across the potential coil of wattmeter B and this meter must read zero. It may therefore be removed, and the algebraic sum of the remaining two wattmeter readings is still the total power drawn by the load. When the location of x is selected in this way, we describe the method of power measurement as the *two-wattmeter* method. The sum of the readings indicates the total power, regardless of (1) load unbalance, (2) source unbalance, (3) differences in the two wattmeters, and (4) the waveform of the periodic source. The only assumption we have made is that wattmeter corrections are sufficiently small so that we can ignore them. In Fig. 19-23, for example, the current coil of each meter has passing through it the line current drawn by the load plus the current taken by the potential coil. Since the latter current is usually quite small, its effect may be estimated from a knowledge of the resistance of the potential coil and the voltage across it. These two quantities enable a close estimate to be made of the power dissipated in the potential coil.

In the numerical example described above, let us now assume that two wattmeters are used, one with current coil in line A and potential coil between lines A and B , the other with current coil in line C and potential coil between C and B . The first meter reads

591 Polyphase Circuits

$$\begin{aligned} P_1 &= E_{AB}I_{aA} \cos(\text{ang } \mathbf{E}_{AB} - \text{ang } \mathbf{I}_{aA}) \\ &= 100(19.3) \cos(15^\circ - 0^\circ) \\ &= 1866 \text{ watts} \end{aligned}$$

and the second

$$\begin{aligned} P_2 &= E_{CB}I_{cC} \cos(\text{ang } \mathbf{E}_{CB} - \text{ang } \mathbf{I}_{cC}) \\ &= 100(10) \cos(-90^\circ - 60^\circ) \\ &= -866 \text{ watts} \end{aligned}$$

and, therefore,

$$P = P_1 + P_2 = 1866 - 866 = 1000 \text{ watts}$$

This we know is the correct answer.

In the case of a balanced load, the two-wattmeter method enables the power-factor angle to be determined, as well as the total power drawn by the load. Let us assume a load impedance with a phase angle θ ; either a Y or Δ connection may be used and we shall assume the Δ connection shown in Fig. 19-24. The construction of a standard phasor diagram, such as that of Fig. 19-20, enables us to determine the proper phase angle between the several line voltages and line currents. We therefore determine the readings

$$\begin{aligned} P_1 &= |E_{AB}| |I_{aA}| \cos(\text{ang } \mathbf{E}_{AB} - \text{ang } \mathbf{I}_{aA}) \\ &= E_L I_L \cos(30^\circ + \theta) \end{aligned}$$

$$\text{and } P_2 = |E_{CB}| |I_{cC}| \cos(\text{ang } \mathbf{E}_{CB} - \text{ang } \mathbf{I}_{cC}) = E_L I_L \cos(30^\circ - \theta)$$

The ratio of the two readings is

$$\frac{P_1}{P_2} = \frac{\cos(30^\circ + \theta)}{\cos(30^\circ - \theta)} \quad (19-2)$$

If we expand the cosine terms, this equation may be solved easily for $\tan \theta$,

$$\tan \theta = \sqrt{3} \frac{P_2 - P_1}{P_2 + P_1} \quad (19-3)$$

Thus, equal wattmeter readings indicate a unity power-factor load, equal and opposite readings indicate a purely reactive load, a reading of P_2 which is (algebraically) greater than P_1 indicates an inductive impedance, and a reading of P_2 which is less than P_1 signifies a capacitive load. How can we tell which wattmeter reads P_1 and which reads P_2 ? It is true that P_1 is in line A , and P_2 is in line C , and our positive phase-sequence system forces \mathbf{E}_{an} to lag \mathbf{E}_{cn} . This is enough information to differentiate between the two wattmeters, but it is confusing to apply in practice. Even if we were unable to distinguish the two, we know the magnitude of the phase angle, but not its sign. This is often sufficient information; if the load is an induction motor, the angle must be positive and we do not need to make any tests to determine which reading is which. If no previous knowledge of the load is assumed, then there are several methods of resolving the ambiguity. Perhaps the simplest method is that which involves

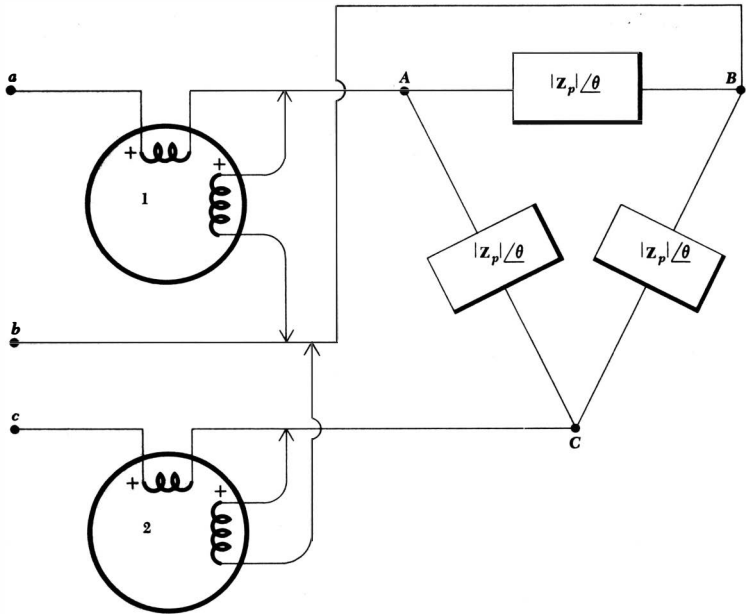

Fig. 19-24 Two wattmeters connected to read the total power drawn by a balanced three-phase load.

adding a high-impedance reactive load, say a three-phase capacitor, across the unknown load. The load must become more capacitive. Thus, if the magnitude of $\tan \theta$ (or the magnitude of θ) decreases, then the load was inductive, whereas an increase in the magnitude of $\tan \theta$ signifies an original capacitive impedance.

Let us suppose that one meter indicates 30 watts while the other reads 100 watts. Since we are assuming a passive load, the sign of the larger reading must be positive, but we must determine the sign of the smaller reading by a careful inspection of the location of the coil terminals marked (+). Let us assume that we know that it actually represents a negative power. Thus, P_1 is either -30 or 100 , and P_2 is either 100 or -30 . The value of $\tan \theta$ is therefore either 3.22 or -3.22 , and the power-factor angle is either 72.7° or -72.7° . We then place three capacitors across the load in a balanced arrangement and find that the reading which was -30 watts is now -27 watts, while the 100 -watt reading has increased to 104 watts. Since neither reading has changed appreciably, we decide that the capacitors have an impedance which is sufficiently high to produce only an incremental change, and we may calculate the new phase angle; it is either $+71.3^\circ$ or -71.3° . The load must now be more capacitive than it was previously, and the only conclusion that can be drawn is that the phase angle was originally 72.7° , whereas now it is 71.3° .

Drill Problems

19-11 Three wattmeters are connected as shown in Fig. 19-23. If $E_{ab} = 100/0^\circ$ volts, $Z_A = Z_B = Z_C = 50 + j0$ ohms, point x is located on point A , and positive phase sequence is assumed, find: (a) P_A ; (b) P_B ; (c) P_C .

Ans. 100 watts; 0 watts; 100 watts

19-12 A certain balanced three-phase system is known to have $E_{ab} = 60/0^\circ$ volts and $I_{aA} = 5/-90^\circ$ amp. Positive phase sequence should be assumed. Find the meter reading, including sign, when the meter is inserted into the three-phase system as shown by the sketches of Fig. 19-25a, b, and c.

Ans. 0 watts; -260 watts; 260 watts

19-13 Two wattmeters are used to measure the power taken by a balanced three-phase load. Find the ratio of the smaller reading to the larger reading, including sign, if the power-factor angle of the load is: (a) 0° ; (b) 60° ; (c) 90° .

Ans. -1; 0; 1

Problems

- ◆1 If $E_{ab} = 100/0^\circ$, $|E_{bc}| = 150$, $|E_{ca}| = 200$, and E_{ab} lags E_{bc} , find E_{bc} and E_{ca} .
- 2 A 100/200 volt rms single-phase three-wire system furnishes two unity power-factor loads with 1.5 kva each at 100 volts and one 4.5-kw load with a lagging power factor of 0.9 at 200 volts. Find the magnitude of the line currents and the current in the neutral.

Fig. 19-25 See Drill Prob. 19-12.

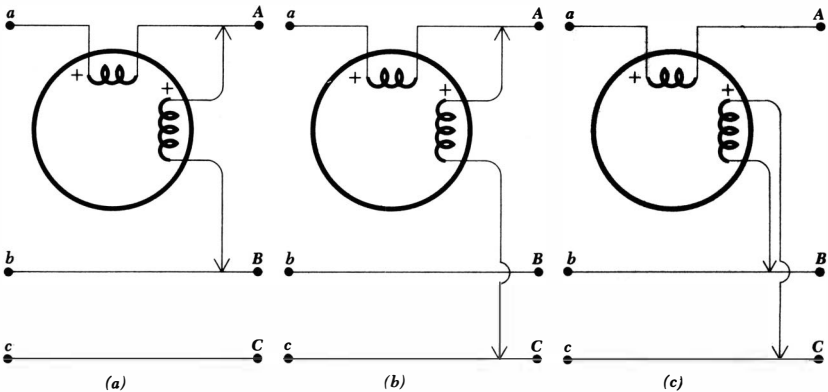

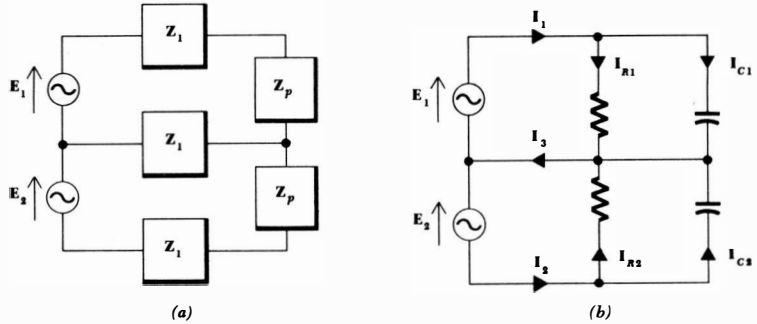

Fig. 19-26 (a) See Prob. 4. (b) See Prob. 5.

- ◆3 A single-phase balanced three-wire system is to be designed around an ideal voltage source which provides 120 and 240 volts. If the system may be called upon to deliver 1 kw each to two low-voltage resistive loads and 5 kw to one high-voltage resistive load, what is the maximum wire resistance permissible in the two lines, if the load voltage is not to drop below 115 volts? What maximum resistance would you recommend for the neutral wire?
- 4 For the single-phase three-wire circuit shown in Fig. 19-26a, $E_1 = E_2 = 115/0^\circ$ volts, $Z_1 = 1 + j0$ ohms, and $Z_p = 18 + j15$ ohms. Find the power loss in each line resistance (Z_1) and the power delivered to each load (Z_p). What is the circuit efficiency?
- 5 In the two-phase circuit shown in Fig. 19-26b, each resistor is 10 ohms and each capacitor is $200/\sqrt{3}$ μf . Assume that $E_1 = 100/0^\circ$ volts, $E_2 = 100/-90^\circ$ volts, and $\omega = 500$. Find and show on a phasor diagram: (a) E_1 ; (b) E_2 ; (c) I_{R1} ; (d) I_{C1} ; (e) I_1 ; (f) I_{R2} ; (g) I_{C2} ; (h) I_2 ; (i) I_3 .
- ◆6 Solve Prob. 4 if $E_1 = 100/0^\circ$ volts and $E_2 = 100/-90^\circ$ volts. Z_1 and Z_p are unchanged.
- 7 Given a balanced three-phase three-wire system with a Y-connected load for which $E_L = 230$ volts and $Z_p = 6 + j8$ ohms, find I_L and the power absorbed by each phase.
- ◆8 A 3-phase induction motor draws 5 kw at 0.8 power factor lagging. What line current will it draw from a 230-volt 3-phase system? The motor may be assumed to be Y-connected.
- 9 Assume that the three lines connecting the 230-volt source of Prob. 7 to the load each have a resistance of 0.5 ohm. Calculate the circuit efficiency. Would the efficiency increase or decrease if Z_p were changed to $10/80^\circ$ ohms?
- ◆10 A three-phase 400-cps aircraft generator with a line voltage of 120 volts furnishes two Y-connected three-phase loads. The first load is 50 ft from the generator and has $Z_{p1} = 8 + j6$ ohms; the second load is 30 ft farther away and has $Z_{p2} = 5 - j4$ ohms. The wire used has a resistance of 0.01

- ohm/ft, and only 240 ft is used. How much power does the generator deliver?
- 11 A set of balanced three-phase line voltages is connected to a balanced Δ -connected load. Each branch of the Δ is $15 + j20$ ohms and $\mathbf{E}_{ab} = 100\angle 0^\circ$ volts. Assume positive phase sequence and find \mathbf{E}_{bc} , \mathbf{E}_{ca} , \mathbf{I}_{AB} , \mathbf{I}_{BC} , \mathbf{I}_{CA} , \mathbf{I}_{aA} , \mathbf{I}_{bB} , \mathbf{I}_{cC} , and the total power delivered to the load.
 - 12 A Δ -connected three-phase 12-kw heater is to be built and operated from a 230-volt system. (a) What resistance is required in each phase? The heater is built and connected to the source with lines each having 1 ohm resistance. (b) What power is delivered to the heater? (c) What source voltage would produce the desired output?
 - 13 For the circuit shown in Fig. 19-27, find: (a) the line current at the source; (b) the total power delivered by the source; and (c) the power factor of the combined load.
 - 14 A three-phase 10-hp induction motor operates at a lagging power factor of 0.866 with an efficiency of 75 per cent from a 230-volt system. (a) What power is delivered by the source? (b) What is the line current?
 - 15 A three-phase 100-volt system is connected to a load drawing 600 watts at 0.707 power factor lagging by three wires each having 1 ohm resistance. (a) Find the line current. (b) Find the total power loss in the lines.
 - 16 A Δ -connected three-phase load has an impedance of $8.66 + j5$ ohms per phase. Assume $\mathbf{E}_{ab} = 50\angle 0^\circ$ and positive phase sequence. Find: (a) \mathbf{E}_{bc} ; (b) \mathbf{E}_{ca} ; (c) \mathbf{I}_{AB} ; (d) \mathbf{I}_{BC} ; (e) \mathbf{I}_{CA} ; (f) \mathbf{I}_{aA} ; (g) \mathbf{I}_{bB} ; (h) \mathbf{I}_{cC} .
 - 17 Use several different methods to find the total power drawn by the load in Prob. 16.
 - 18 One wattmeter is inserted in the circuit of Prob. 16 in several different ways, as shown in Fig. 19-28*a*, *b*, and *c*. Determine the meter reading in each case and state whether or not any connections had to be changed to produce an upscale deflection.
 - 19 Three wattmeters are used in the three-phase system of Prob. 16. Find the (algebraic) reading of each wattmeter if the scheme of connections is shown in Fig. 19-29.
 - 20 A student in the laboratory using the two-wattmeter method of measuring power drawn by a 110-volt three-phase passive load, which is known to be

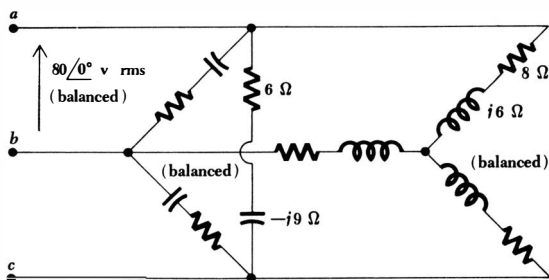

Fig. 19-27 See Prob. 13.

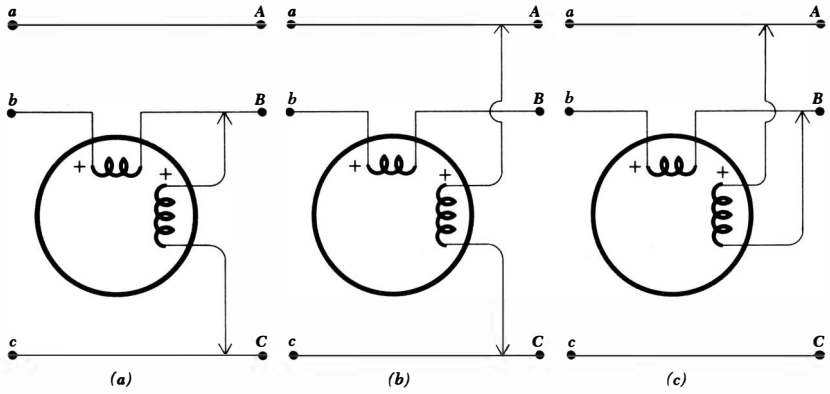

Fig. 19-28 See Prob. 18.

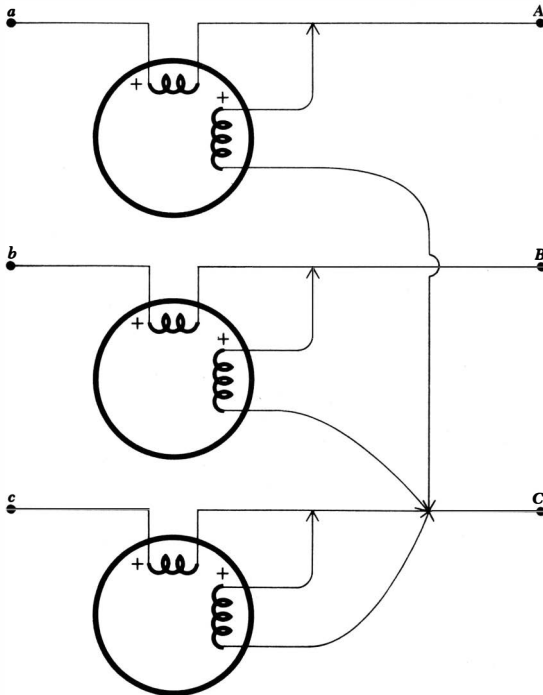

Fig. 19-29 See Prob. 19.

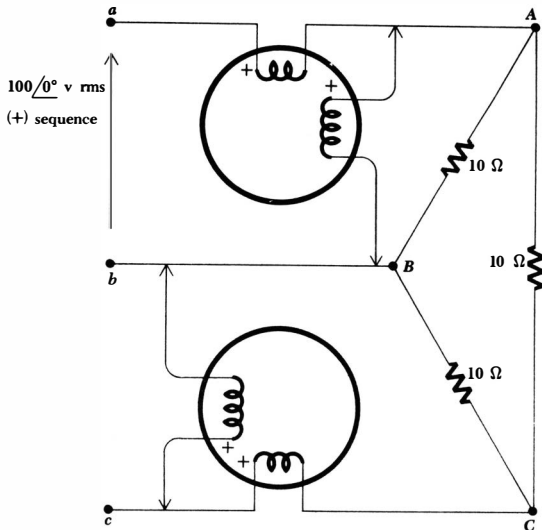

Fig. 19-30 See Prob. 24.

- balanced, states that the meters read 1 kw and 5 kw, but he never checked to see whether either reading was negative. (a) What are the possible values of the total power taken by the load? (b) What are the possible values of the impedance phase angle? (c) If the load is assumed to be Δ -connected, find the four different values of phase impedance which the load might have.
- 21 The three lines of a three-phase system are discovered in an underground conduit in enemy territory. Assume that only one wattmeter is available and that one terminal of each coil is marked with a (+). Describe a method that might be used to indicate the direction in which the generating station or substation lies. How could the current coil be inserted in a line without interrupting service?
- 22 Assume that there are three identical resistive loads which must each be furnished P watts at E volts. They are to be connected to a single-phase source by two conductors. (a) Assume that the loads are in parallel and that the conductors each have a resistance of R_p ohms. Find the total conductor losses. (b) Now let the loads be placed in series, use a conductor resistance of R_s ohms, and again calculate the total conductor losses. (c) One of the maxims of the power industry is that the losses are lower on higher-voltage systems. Is this borne out by the example above? (d) If the values of R_s and R_p are chosen to provide equal losses, what is the ratio of the total conductor weight in one system to that in the other? How about the conductor costs?
- 23 The three loads described in Prob. 22 are now to be operated from a three-phase system. (a) Assume a Δ connection, use lines each having a resist-

- ance of R_{Δ} ohms, and compute the total conductor losses. (b) Repeat part a for a Y connection with line resistances of R_Y ohms. (c) Compare the total conductor weight and cost of the two three-phase systems described above if each has the same total conductor losses. (d) Since the line losses are very dependent on line voltage, any comparison between single-phase and three-phase operation should be made for systems having identical line voltages. Compare the total conductor weight and cost of the three-phase system of part a above with the single-phase system described in Prob. 22a if the line losses in the two systems are equal.
- ◆ 24 Determine each of the wattmeter readings and also the total load power for the circuit shown in Fig. 19-30.

Chapter 20 *Fourier Analysis*

20-1 INTRODUCTION

In this chapter we shall conclude our introduction to circuit analysis by extending the frequency-domain concept to include forcing functions and responses which are not in general sinusoids, exponentials, or damped sinusoids. Our goal is a generalization of the process of determining the forced response.

The complete response of a linear circuit to an arbitrary forcing function is composed of the sum of a forced response and a natural response. The natural response was initially considered in Chaps. 5 to 8, but with few exceptions, only simple series or parallel RL , RC , and RLC circuits were examined. However, the complex-frequency concept in Chap. 14 provided us with a general method of obtaining the natural response; we discovered that we could write the form of the natural response after inspecting the pole-zero constellation of an appropriate immittance or transfer function of the network. Thus, a powerful general method for determining the natural response became available.

Now let us consider our status with respect to the forced response. We are able to find the forced response in any purely resistive linear circuit, regardless of the nature of the forcing function, but this can hardly be classed as a scientific breakthrough. If the circuit includes energy-storage elements, then we can find the forced response only for those circuits and forcing functions to which we can apply the impedance concept; that is, the forcing function must be direct current, exponential, sinusoidal, or damped sinusoidal. This is the barrier which we seek to remove in this chapter.

We shall begin by considering forcing functions which are *periodic* and have functional natures which satisfy certain mathematical restrictions that are characteristic of any function which we can generate in the laboratory. Any such function may be represented as the sum of an infinite number of sine and cosine functions which are harmonically related. Therefore, since the forced response to each sinusoidal component may be determined easily by sinusoidal steady-

state analysis, the response of the linear network to the general periodic forcing function may be obtained by superposing the partial responses.

Some feeling for the validity of representing a general periodic function by an infinite sum of sine and cosine functions may be gained by considering a simple example. Let us first assume a cosine function of radian frequency ω_0 ,

$$e_1(t) = 2 \cos \omega_0 t$$

where

$$\omega_0 = 2\pi f_0$$

and the period T is

$$T = \frac{1}{f_0} = \frac{2\pi}{\omega_0}$$

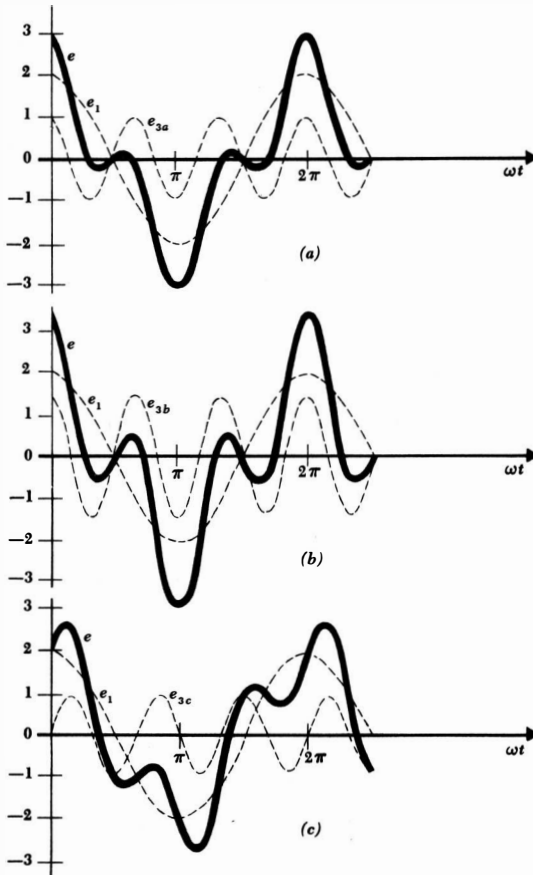

Fig. 20-1 Several of the infinite number of different waveforms which may be obtained by combining a fundamental and a third harmonic. The fundamental is $e_1 = 2 \cos \omega_0 t$, and the third harmonic is: (a) $e_{3a} = \cos 3\omega_0 t$; (b) $e_{3b} = 1.5 \cos 3\omega_0 t$; (c) $e_{3c} = \sin 3\omega_0 t$.

601 *Fourier Analysis*

The *harmonics* of this sinusoid have frequencies $n\omega_0$, where ω_0 is the fundamental frequency and $n = 1, 2, 3, \dots$. The frequency of the first harmonic is the fundamental frequency. Next let us select a third harmonic voltage

$$e_{3a}(t) = \cos 3\omega_0 t$$

The fundamental $e_1(t)$, the third harmonic $e_{3a}(t)$, and the sum of these two waves are shown as functions of time in Fig. 20-1a. It should be noted that the sum is periodic with period $T = 2\pi/\omega_0$.

The form of the resultant periodic function changes as the phase and amplitude of the third harmonic component change. Thus, Fig. 20-1b shows the effect of combining $e_1(t)$ and a third harmonic of slightly larger amplitude,

$$e_{3b}(t) = 1.5 \cos 3\omega_0 t$$

By shifting the phase of the third harmonic,

$$e_{3c}(t) = \sin 3\omega_0 t$$

the sum, shown in Fig. 20-1c, takes on a still different character. In all cases, the period of the resultant waveform is the same as the period of the fundamental waveform. The nature of the waveform depends on the amplitude and phase of every possible harmonic component, and we shall find it possible to generate waveforms which have an extremely nonsinusoidal character by an appropriate combination of sinusoidal functions.

After we have become familiar with the use of an infinite sum of sine and cosine functions to represent a periodic waveform, we shall briefly consider the frequency-domain representation of a general nonperiodic waveform.

20-2 TRIGONOMETRIC FORM OF THE FOURIER SERIES

We first consider a *periodic* function $f(t)$ defined in Sec. 12-3 by the functional relationship

$$f(t) = f(t + T)$$

where T is the period. We shall further assume that the function $f(t)$ satisfies the following properties:

- 1: $f(t)$ is single-valued everywhere.
2. The integral $\int_{t_0}^{t_0+T} |f(t)| dt$ exists (i.e., is not infinite) for any choice of t_0 .
3. $f(t)$ has a finite number of discontinuities in any one period.
4. $f(t)$ has a finite number of maxima and minima in any one period.

We shall consider $f(t)$ to represent a voltage or current waveform, and any voltage or current waveform which we can actually produce must satisfy these conditions. Certain mathematical functions which we might hypothesize may not satisfy these conditions, but we shall assume that the four conditions listed above are always satisfied.

Given such a periodic function $f(t)$, the Fourier theorem¹ states that $f(t)$ may be represented by the infinite series

$$\begin{aligned} f(t) &= a_0 + a_1 \cos \omega_0 t + a_2 \cos 2\omega_0 t + \cdots + b_1 \sin \omega_0 t + b_2 \sin 2\omega_0 t + \cdots \\ &= a_0 + \sum_{n=1}^{\infty} (a_n \cos n\omega_0 t + b_n \sin n\omega_0 t) \end{aligned} \quad (20-1)$$

where the fundamental frequency ω_0 is related to the period T by

$$\omega_0 = \frac{2\pi}{T}$$

and where a_0 and the a_n and b_n are constants which depend upon n and $f(t)$. Equation (20-1) is the trigonometric form of the *Fourier series for $f(t)$* , and the process of determining the values of the constants a_0 , a_n , and b_n is called *Fourier analysis*. Our object is not the proof of this theorem, but only a simple development of the procedures of Fourier analysis and a feeling that the theorem is justifiable.

Before we discuss the evaluation of the constants appearing in the Fourier series, let us collect a set of useful trigonometric integrals. We shall let both n and k represent any of the set of integers 1, 2, 3, In the following integrals, we shall use 0 and T as the integration limits, but it is understood that any interval of one period is equally correct. Since the average value of a sinusoid over one period is zero,

$$\int_0^T \sin n\omega_0 t \, dt = 0 \quad (20-2)$$

$$\text{and} \quad \int_0^T \cos n\omega_0 t \, dt = 0 \quad (20-3)$$

It is also a simple matter to show that the following three definite integrals are zero:

$$\int_0^T \sin k\omega_0 t \cos n\omega_0 t \, dt = 0 \quad (20-4)$$

$$\int_0^T \sin k\omega_0 t \sin n\omega_0 t \, dt = 0 \quad k \neq n \quad (20-5)$$

$$\int_0^T \cos k\omega_0 t \cos n\omega_0 t \, dt = 0 \quad k \neq n \quad (20-6)$$

Those cases which are excepted in Eqs. (20-5) and (20-6) are also easily evaluated; we obtain

$$\int_0^T \sin^2 n\omega_0 t \, dt = \frac{T}{2} \quad (20-7)$$

$$\int_0^T \cos^2 n\omega_0 t \, dt = \frac{T}{2} \quad (20-8)$$

¹Jean-Baptiste Joseph Fourier published this theorem in 1822. Some rather unbelievable pronunciations of this French name come from American students; it should rhyme with "poor today."

The evaluation of the unknown constants may now be accomplished readily. We first attack a_0 . If we integrate each side of the Fourier series (20-1) over a full period, we obtain

$$\int_0^T f(t) dt = \int_0^T a_0 dt + \int_0^T \sum_{n=1}^{\infty} (a_n \cos n\omega_0 t + b_n \sin n\omega_0 t) dt$$

But every term in the summation is of the form of Eq. (20-2) or Eq. (20-3), and thus

$$\int_0^T f(t) dt = a_0 T$$

or
$$a_0 = \frac{1}{T} \int_0^T f(t) dt \quad (20-9)$$

This constant a_0 is simply the average value of $f(t)$ over a period, and we therefore describe it as the d-c component of $f(t)$.

To evaluate one of the cosine coefficients, say a_k , the coefficient of $\cos k\omega_0 t$, we first multiply each side of Eq. (20-1) by $\cos k\omega_0 t$ and then integrate both sides of the equation over a full period:

$$\begin{aligned} \int_0^T f(t) \cos k\omega_0 t dt &= \int_0^T a_0 \cos k\omega_0 t dt + \int_0^T \sum_{n=1}^{\infty} a_n \cos k\omega_0 t \cos n\omega_0 t dt \\ &\quad + \int_0^T \sum_{n=1}^{\infty} b_n \cos k\omega_0 t \sin n\omega_0 t dt \end{aligned}$$

From Eqs. (20-3), (20-4), and (20-6) we note that every term on the right side of the equation with one exception is zero. That term is evaluated by Eq. (20-8), and we obtain

$$a_k = \frac{2}{T} \int_0^T f(t) \cos k\omega_0 t dt \quad (20-10)$$

This result is twice the average value of the product $f(t) \cos k\omega_0 t$ over a period.

In a similar way, we obtain b_k by multiplying by $\sin k\omega_0 t$, integrating over a period, noting that all but one of the terms on the right side are zero, and performing that single integration by Eq. (20-7). The result is

$$b_k = \frac{2}{T} \int_0^T f(t) \sin k\omega_0 t dt \quad (20-11)$$

which is twice the average value of $f(t) \sin k\omega_0 t$ over a period.

Equations (20-9) to (20-11) now enable us to determine values for a_0 and all the a_n and b_n in the Fourier series (20-1).

Let us consider a numerical example. The "half-sinusoidal" waveform shown in Fig. 20-2a represents the voltage response obtained at the output of a half-wave rectifier circuit, a nonlinear circuit whose function is to convert a sinusoidal input voltage to a (pulsating) d-c output voltage. In order to represent this voltage as a Fourier series, we must first determine the period and then express

the graphical voltage as an analytical function of time. From the graph, the period is seen to be

$$T = 0.4 \text{ sec}$$

and thus

$$f_0 = 2.5 \text{ cps}$$

and $\omega_0 = 5\pi$ radians/sec

With these three quantities determined, we now seek an appropriate expression for $f(t)$ or $e(t)$ which is valid throughout the period. Obtaining this equation or set of equations proves to be the most difficult part of Fourier analysis for many students. The source of the difficulty is apparently either the inability to recognize the given curve, carelessness in determining multiplying constants within the functional expression, or negligence in not writing the complete expression. In this example, the statement of the problem infers that the functional form is a sinusoid; the amplitude is E_m , the radian frequency has already been determined as 5π , and only the positive portion of the cosine wave is present. The functional expression for the period $t = 0$ to $t = 0.4$ is therefore

$$e(t) = \begin{cases} E_m \cos 5\pi t & 0 \leq t \leq 0.1 \\ 0 & 0.1 \leq t \leq 0.3 \\ E_m \cos 5\pi t & 0.3 \leq t \leq 0.4 \end{cases}$$

It is evident that the choice of the period extending from $t = -0.1$ to $t = 0.3$ will result in fewer equations and, hence, fewer integrals:

$$e(t) = \begin{cases} E_m \cos 5\pi t & -0.1 \leq t \leq 0.1 \\ 0 & 0.1 \leq t \leq 0.3 \end{cases} \quad (20-12)$$

This form is preferable, although either description will yield the correct results.

The zero-frequency component is easily obtained:

$$\begin{aligned} a_0 &= \frac{1}{0.4} \int_{-0.1}^{0.3} e(t) dt \\ &= \frac{1}{0.4} \left[\int_{-0.1}^{0.1} E_m \cos 5\pi t dt + \int_{0.1}^{0.3} (0) dt \right] \end{aligned}$$

$$\text{and } a_0 = \frac{E_m}{\pi} \quad (20-13)$$

Notice that the integral must be broken up into a number of integrals, each over a portion of the period, where each integral corresponds to one of the functional forms used to express $e(t)$ over the complete period.

The amplitude of a general cosine term is

$$a_k = \frac{2}{0.4} \int_{-0.1}^{0.1} E_m \cos 5\pi t \cos 5\pi k t dt$$

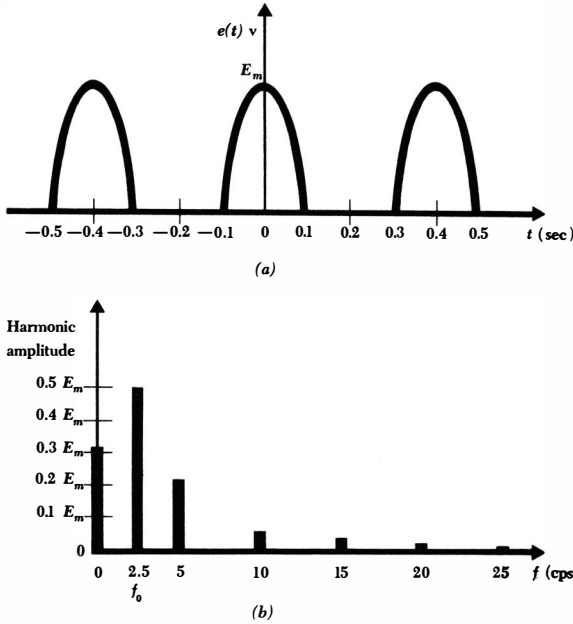

Fig. 20-2 (a) The output of a half-wave rectifier to which a sinusoidal input is applied. (b) The discrete line spectrum of the waveform of (a).

The form of the function we obtain upon integrating is different when k is unity than it is for any other choice of k . If $k = 1$, we have

$$a_1 = 5E_m \int_{-0.1}^{0.1} \cos^2 5\pi t \, dt = \frac{E_m}{2} \tag{20-14}$$

whereas if k is not equal to unity, we find

$$\begin{aligned} a_k &= 5E_m \int_{-0.1}^{0.1} \cos 5\pi t \cos 5\pi k t \, dt \\ &= 5E_m \int_{-0.1}^{0.1} \frac{1}{2} [\cos 5\pi(1+k)t + \cos 5\pi(1-k)t] \, dt \end{aligned}$$

or
$$a_k = \frac{2E_m}{\pi} \frac{\cos(\pi k/2)}{1 - k^2} \quad k \neq 1 \tag{20-15}$$

Some of the details of the integration have been left out for those who prefer to work out the small tedious steps for themselves. It should be pointed out, incidentally, that the expression for a_k when $k \neq 1$ will yield the correct result for $k = 1$ if L'Hôpital's rule is applied.

A similar integration shows that all the b_k are zero, and the Fourier series

thus contains no sine terms. The Fourier series is therefore obtained from Eqs. (20-13) to (20-15):

$$e(t) = \frac{E_m}{\pi} + \frac{E_m}{2} \cos 5\pi t + \frac{2E_m}{3\pi} \cos 10\pi t - \frac{2E_m}{15\pi} \cos 20\pi t + \frac{2E_m}{35\pi} \cos 30\pi t - \dots \quad (20-16)$$

In Fig. 20-2a, $e(t)$ is shown as a function of time; in Eq. (20-12), $e(t)$ is expressed as an analytical function of time. Either of these representations is a time-domain representation. Equation (20-16), the Fourier series representation of $e(t)$, is also a time-domain expression, but it may be transformed easily into a frequency-domain representation. For example, we could locate the points in the s plane that represent the frequencies present in Eq. (20-16). The result would be a mark at the origin and symmetrical marks on the positive and negative $j\omega$ axes. A more customary method of presenting this information, and one which shows the amplitude of each frequency component, is by a *line spectrum*. A line spectrum for Eq. (20-16) is shown in Fig. 20-2b; the amplitude of each frequency component is indicated by the length of the vertical line located

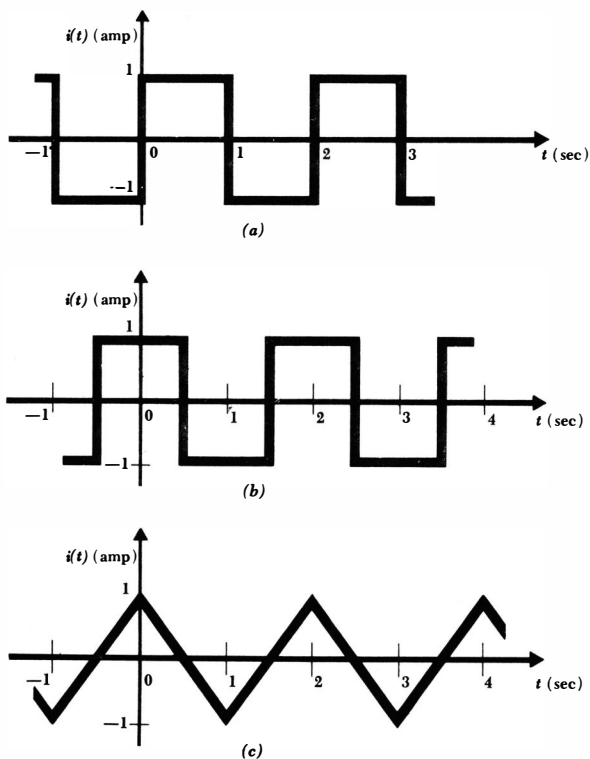

Fig. 20-3 See Drill Prob. 20-2.

at the corresponding frequency. We also speak of this spectrum as a *discrete* spectrum because any finite frequency interval contains only a finite number of frequency components.

One note of caution must be injected. The example we have considered contains no sine terms, and the amplitude of the k th harmonic is therefore $|a_k|$. If b_k is not zero, then the amplitude of the component at a frequency $k\omega_0$ must be $\sqrt{a_k^2 + b_k^2}$. This is the general quantity which we must show in a line spectrum. When we discuss the complex form of the Fourier series, we shall see that this quantity is obtained more directly.

The Fourier series obtained for this example includes no sine terms and no odd harmonics (except the fundamental) among the cosine terms. It is possible to anticipate the absence of certain terms in a Fourier series before any integrations are performed, by an inspection of the symmetry of the given time function. We shall investigate the use of symmetry in the following section.

Drill Problems

20-1 Determine the amplitude of the 100-cps component of each of the following voltage waveforms:

- (a) $e = 50$ volts, $0 < t < 0.025$ sec; $e = 0$, $0.025 < t < 0.05$ sec;
 $T = 0.05$ sec
- (b) $e = 50$ volts, $-0.01 < t < 0.025$ sec; $e = 0$, $0.025 < t < 0.04$ sec;
 $T = 0.05$ sec
- (c) $e = 50$ volts, $-0.0125 < t < 0.0125$ sec; $e = 0$, $0.0125 < t < 0.0375$ sec;
 $T = 0.05$ sec

Ans. 6.37 volts; 6.37 volts; 6.37 volts

20-2 Write the Fourier series for the three current waveforms shown in Fig. 20-3.

$$\text{Ans. } \frac{4}{\pi}(\sin \pi t + \frac{1}{3} \sin 3\pi t + \frac{1}{5} \sin 5\pi t + \dots) \text{ amp}$$

$$\frac{4}{\pi}(\cos \pi t - \frac{1}{3} \cos 3\pi t + \frac{1}{5} \cos 5\pi t - \dots) \text{ amp}$$

$$\frac{8}{\pi^2}(\cos \pi t + \frac{1}{9} \cos 3\pi t + \frac{1}{25} \cos 5\pi t + \dots) \text{ amp}$$

20-3 THE USE OF SYMMETRY

The two types of symmetry which are most readily recognized are *even-function symmetry* and *odd-function symmetry*, or simply *even symmetry* and *odd symmetry*. We say that $f(t)$ possesses the property of even symmetry if

$$f(t) = f(-t) \tag{20-17}$$

Such functions as t^2 , $\cos 3t$, $\ln(\cos t)$, $\sin^2 7t$, and a constant all possess even sym-

metry; the replacement of t by $(-t)$ does not change the value of any of these functions. This type of symmetry may also be recognized graphically, for if $f(t) = f(-t)$ then mirror symmetry exists about the $f(t)$ axis. The function shown in Fig. 20-4a possesses even symmetry; if the figure were to be folded along the $f(t)$ axis, then the portions of the graph of the function for positive and negative time would fit exactly, one on top of the other.

Now let us investigate the effects that even symmetry produces in a Fourier series. If we think of the expression which equates an even function $f(t)$ and an infinite sum of sine and cosine functions, then it is apparent that the infinite sum must also be an even function. A sine wave, however, is an odd function, and no sum of sine waves can produce any even function other than zero (which is both even and odd). It is thus plausible that the Fourier series of any even function is composed of only a constant and cosine functions. Let us now show carefully that $b_k = 0$. We have

$$\begin{aligned} b_k &= \frac{2}{T} \int_{-T/2}^{T/2} f(t) \sin k\omega_0 t \, dt \\ &= \frac{2}{T} \left[\int_{-T/2}^0 f(t) \sin k\omega_0 t \, dt + \int_0^{T/2} f(t) \sin k\omega_0 t \, dt \right] \end{aligned}$$

Now let us replace the variable t in the first integral by $-\tau$, or $\tau = -t$, and make use of the fact that $f(t) = f(-t) = f(\tau)$:

$$\begin{aligned} b_k &= \frac{2}{T} \left[-\int_{T/2}^0 f(-\tau) \sin(-k\omega_0\tau) \, d\tau + \int_0^{T/2} f(t) \sin k\omega_0 t \, dt \right] \\ &= \frac{2}{T} \left[-\int_0^{T/2} f(\tau) \sin k\omega_0\tau \, d\tau + \int_0^{T/2} f(t) \sin k\omega_0 t \, dt \right] \end{aligned}$$

But the symbol we use to identify the variable of integration cannot affect the value of the integral. Hence,

$$b_k = 0 \quad (20-18)$$

Thus, no sine terms are present. A similar examination of the expression for a_k leads to an integral over the *half period* extending from $t = 0$ to $t = \frac{1}{2}T$:

$$a_k = \frac{4}{T} \int_0^{T/2} f(t) \cos k\omega_0 t \, dt \quad (20-19)$$

The fact that a_k is obtained for an even function by taking "twice the integral over half the range" should seem logical.

We define odd symmetry by stating that if odd symmetry is a property of $f(t)$, then

$$f(t) = -f(-t) \quad (20-20)$$

In other words, if t is replaced by $(-t)$, then the negative of the given function is obtained; for example, t , $\sin t$, $t \cos 70t$, $t\sqrt{1+t^2}$, and the function sketched in Fig. 20-4b are all odd functions and possess odd symmetry. The graphical characteristics of odd symmetry are apparent if the portion of $f(t)$ for $t > 0$ is

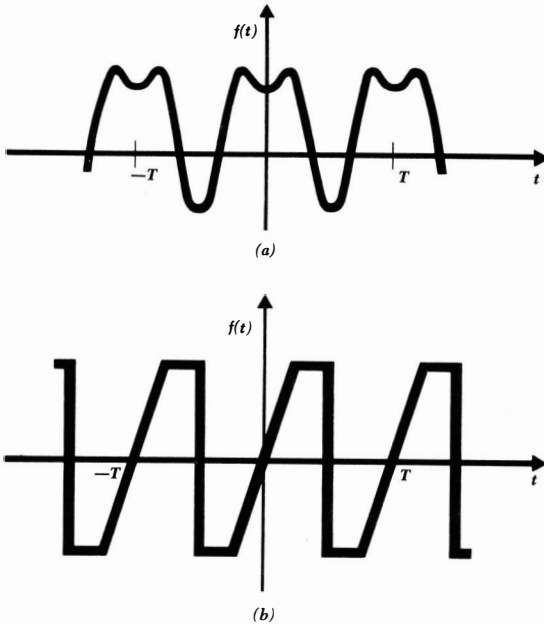

Fig. 20-4 (a) A waveform showing even symmetry. (b) A waveform showing odd symmetry.

rotated about the positive t axis and the resultant figure is then rotated about the $f(t)$ axis; the two curves will fit exactly, one on top of the other.

A function having odd symmetry can contain no constant term or cosine terms in its Fourier expansion. Let us prove the second part of this statement. We have

$$\begin{aligned}
 a_k &= \frac{2}{T} \int_{-T/2}^{T/2} f(t) \cos k\omega_0 t \, dt \\
 &= \frac{2}{T} \left[\int_{-T/2}^0 f(t) \cos k\omega_0 t \, dt + \int_0^{T/2} f(t) \cos k\omega_0 t \, dt \right]
 \end{aligned}$$

and we now let $t = -\tau$ in the first integral,

$$\begin{aligned}
 a_k &= \frac{2}{T} \left[-\int_{T/2}^0 f(-\tau) \cos(-k\omega_0\tau) \, d\tau + \int_0^{T/2} f(t) \cos k\omega_0 t \, dt \right] \\
 &= \frac{2}{T} \left[\int_0^{T/2} f(-\tau) \cos k\omega_0\tau \, d\tau + \int_0^{T/2} f(t) \cos k\omega_0 t \, dt \right]
 \end{aligned}$$

But $f(-\tau) = -f(\tau)$, and therefore

$$a_k = 0 \tag{20-21}$$

A similar, but simpler, proof shows that

$$a_0 = 0$$

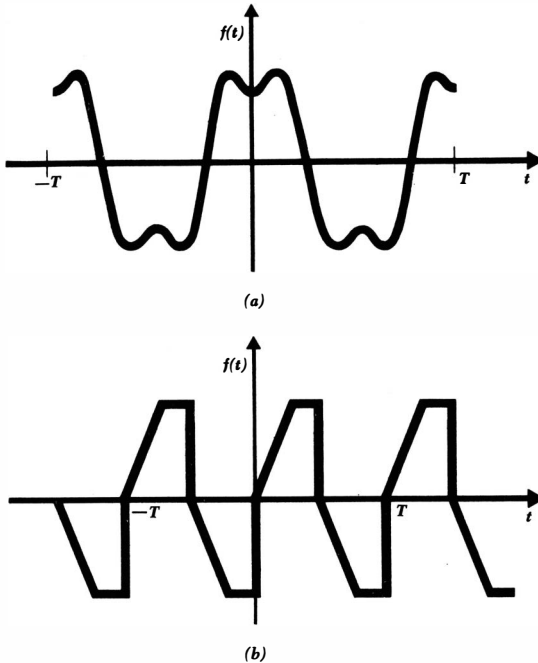

Fig. 20-5 (a) A waveform somewhat similar to the one shown in Fig. 20-4a, but possessing half-wave symmetry. (b) A waveform somewhat similar to the one shown in Fig. 20-4b, but possessing half-wave symmetry.

Furthermore, the values for b_k may again be obtained by integrating over half the range:

$$b_k = \frac{4}{T} \int_0^{T/2} f(t) \sin k\omega_0 t \, dt \quad (20-22)$$

Examples of even and odd symmetry are afforded by Drill Prob. 20-2, following the previous section. In both parts a and b, a square wave of the same amplitude and period is the given function. The time origin, however, is selected to provide odd symmetry in (a) and even symmetry in (b), and the resultant series contain, respectively, only sine terms and cosine terms. It is also worthwhile pointing out that the point at which $t = 0$ could be selected to provide neither even nor odd symmetry; the determination of the coefficients of the terms in the Fourier series then takes twice as long.

The Fourier series for either of these square waves also have one other interesting characteristic; neither contains any even harmonics.² That is, the only frequency components present in the series have frequencies which are odd multiples of the fundamental frequency; a_k and b_k are zero for k even.

² Constant vigilance is required to avoid confusion between an even function and an even harmonic, or an odd function and an odd harmonic. Thus, b_{10} is the coefficient of an even harmonic, and it is zero if $f(t)$ is an even function.

611 Fourier Analysis

This result is caused by another type of symmetry, called half-wave symmetry. We shall say that $f(t)$ possesses *half-wave symmetry* if

$$f(t) = -f(t - \frac{1}{2}T)$$

Except for a change of sign, each half cycle is like the adjacent half cycles. Half-wave symmetry, unlike even and odd symmetry, is not a function of the choice of the point $t = 0$. Thus, we can state that the square wave (Fig. 20-3a or b) shows half-wave symmetry. Neither waveform shown in Fig. 20-4 has half-wave symmetry, but the two somewhat similar functions plotted in Fig. 20-5 do possess half-wave symmetry.

It may be shown that the Fourier series of any function which has half-wave symmetry contains only odd harmonics. Let us consider the coefficients a_k . We have again

$$\begin{aligned} a_k &= \frac{2}{T} \int_{-T/2}^{T/2} f(t) \cos k\omega_0 t \, dt \\ &= \frac{2}{T} \left[\int_{-T/2}^0 f(t) \cos k\omega_0 t \, dt + \int_0^{T/2} f(t) \cos k\omega_0 t \, dt \right] \end{aligned}$$

which we may represent as

$$a_k = \frac{2}{T} (I_1 + I_2)$$

Now we substitute the new variable $\tau = t + \frac{1}{2}T$ into integral I_1 :

$$\begin{aligned} I_1 &= \int_0^{T/2} f(\tau - \frac{1}{2}T) \cos k\omega_0(\tau - \frac{1}{2}T) \, d\tau \\ &= \int_0^{T/2} -f(\tau) \left(\cos k\omega_0\tau \cos \frac{k\omega_0 T}{2} + \sin k\omega_0\tau \sin \frac{k\omega_0 T}{2} \right) \, d\tau \end{aligned}$$

But $\omega_0 T$ is 2π radians, and thus

$$\sin \frac{k\omega_0 T}{2} = \sin k\pi = 0$$

Hence

$$I_1 = -\cos k\pi \int_0^{T/2} f(\tau) \cos k\omega_0\tau \, d\tau$$

After noting the form of I_2 , we therefore may write

$$a_k = \frac{2}{T} (1 - \cos k\pi) \int_0^{T/2} f(t) \cos k\omega_0 t \, dt$$

The factor $(1 - \cos k\pi)$ indicates that a_k is zero if k is even. When k is odd, we have

$$a_k = \frac{4}{T} \int_0^{T/2} f(t) \cos k\omega_0 t \, dt \quad k \text{ odd} \quad (20-23)$$

A similar investigation shows that b_k is also zero for all even k , and when k is odd

$$b_k = \frac{4}{T} \int_0^{T/2} f(t) \sin k\omega_0 t \, dt \quad k \text{ odd} \quad (20-24)$$

It should be noted that half-wave symmetry may be present in a waveform which also shows odd symmetry or even symmetry. The waveform sketched in Fig. 20-5a, for example, possesses both even symmetry and half-wave symmetry. Its Fourier series therefore contains only odd-harmonic cosine functions; the values of a_k may be determined from Eq. (20-23) [once the functional form for $f(t)$ is known]. It is always worthwhile spending a few moments investigating the symmetry of a function for which a Fourier series is to be determined.

Drill Problems

20-3 Sketch each of the functions described below and determine whether or not even symmetry, odd symmetry, and half-wave symmetry are present:

- (a) $e = 2t, 0 \leq t \leq 5; e = 20 - 2t, 5 \leq t \leq 10$; repeats
 (b) $e = 2t - 5, 0 \leq t \leq 5; e = 15 - 2t, 5 \leq t \leq 10$; repeats
 (c) $e = 4, 0 < t < 2; e = 6, 2 < t < 5; e = -4, 5 < t < 7; e = -6, 7 < t < 10$; repeats

Ans. Yes, no, no; no, no, yes; yes, no, yes

20-4 Which of the constants $a_0, a_1, a_2, a_3, b_1, b_2,$ and b_3 in the Fourier series for $f(t)$ must be zero if $f(t)$ possesses the following symmetry: (a) half-wave? (b) odd and half-wave? (c) even and half-wave?

Ans. $a_0, a_2, b_1, b_2, b_3; a_0, a_1, a_2, a_3, b_2; a_0, a_2, b_2$

20-5 Determine the Fourier series for each of the functions described in Drill Prob. 20-3.

$$\text{Ans. } -\frac{40}{\pi^2} \sum_{\substack{n=1 \\ \text{odd}}}^{\infty} \frac{1}{n^2} \cos \frac{n\pi t}{5} \text{ volts; } \quad 5 - \frac{40}{\pi^2} \sum_{\substack{n=1 \\ \text{odd}}}^{\infty} \frac{1}{n^2} \cos \frac{n\pi t}{5} \text{ volts;}$$

$$\frac{4}{\pi} \sum_{\substack{n=1 \\ \text{odd}}}^{\infty} \frac{1}{n} \left[-\sin \frac{2\pi n}{5} \cos \frac{n\pi t}{5} + \left(5 + \cos \frac{2\pi n}{5} \right) \sin \frac{n\pi t}{5} \right] \text{ volts}$$

20-4 COMPLETE RESPONSE TO PERIODIC FORCING FUNCTIONS

Through the use of the Fourier series, we may now express an arbitrary periodic forcing function as an infinite sum of sinusoidal forcing functions; the forced response to each of these functions may be determined by conventional steady-state analysis; the form of the natural response may be determined from the pole-zero constellation of the appropriate network function; the initial conditions existing throughout the network, including the initial value of the forced

response, enable the amplitude of the natural response to be selected; and, finally, the complete response is obtained as the sum of the forced and natural responses. Let us illustrate this general procedure by a specific example.

We shall apply the square wave of Fig. 20-6a, which includes a d-c component, to the series RL circuit, as shown in Fig. 20-6b. The forcing function is applied at $t = 0$, and the current is the desired response. Its initial value is zero. The forcing function has a fundamental frequency $\omega_0 = 2$, and its Fourier series may be written down by comparison with the solution of Drill Prob. 20-2a:

$$e(t) = 5 + \frac{20}{\pi} \sum_{\substack{n=1 \\ \text{odd}}}^{\infty} \frac{\sin 2nt}{n}$$

We shall find the forced response by working in the frequency domain of the k th harmonic. Thus,

$$e_k(t) = \frac{20}{\pi k} \sin 2kt$$

and
$$\mathbf{E}_k = \frac{20}{\pi k} (-j1)$$

The impedance offered by the RL circuit at this frequency is

$$\mathbf{Z}_k = 4 + j(2k)2 = 4 + j4k$$

and thus the component of the forced response at this frequency is

$$\mathbf{I}_k = \frac{\mathbf{E}_k}{\mathbf{Z}_k} = \frac{-j5}{\pi k(1 + jk)}$$

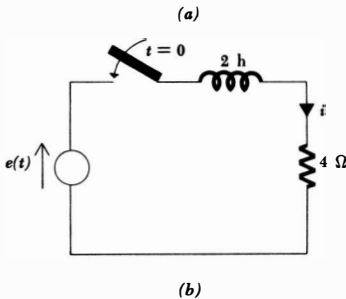
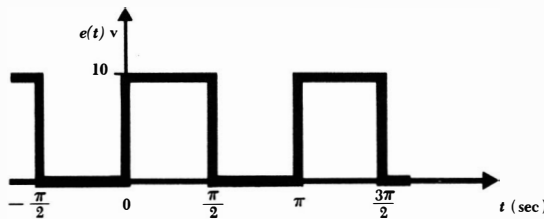

Fig. 20-6 (a) A square-wave voltage forcing function. (b) The forcing function of (a) is applied to this series RL circuit at $t = 0$; the complete response $i(t)$ is desired.

614 Special Topics

Transforming to the time domain, we have

$$\begin{aligned} i_k(t) &= \frac{5}{\pi k} \frac{1}{\sqrt{1+k^2}} \cos(2kt - 90^\circ - \tan^{-1} k) \\ &= \frac{5}{\pi(1+k^2)} \left(\frac{\sin 2kt}{k} - \cos 2kt \right) \end{aligned}$$

Since the response to the d-c component is obviously 1.25 amp, the forced response may be expressed as the summation

$$i_f(t) = 1.25 + \frac{5}{\pi} \sum_{\substack{k=1 \\ \text{odd}}}^{\infty} \left[\frac{\sin 2kt}{k(1+k^2)} - \frac{\cos 2kt}{1+k^2} \right]$$

The familiar natural response of this simple circuit is the single exponential term (characterizing the single zero of the input impedance)

$$i_n(t) = A\epsilon^{-2t}$$

The complete response is therefore the sum

$$i(t) = i_f(t) + i_n(t)$$

and, since $i(0) = 0$, it is necessary to select A so that

$$A = -i_f(0)$$

Letting $t = 0$, we find that $i_f(0)$ is given by

$$i_f(0) = 1.25 - \frac{5}{\pi} \sum_{\substack{k=1 \\ \text{odd}}}^{\infty} \frac{1}{1+k^2}$$

Although we could express A in terms of this summation, it is more convenient to use the numerical value of the summation. The sum of the first 5 terms of $\Sigma 1/(1+k^2)$ is 0.671, the sum of the first 10 terms is 0.695, the sum of the first 20 terms is 0.708, and the exact sum is 0.720 to three significant figures. Thus

$$A = -1.25 + \frac{5}{\pi} 0.720 = -0.104$$

$$\text{and} \quad i(t) = -0.104\epsilon^{-2t} + 1.25 + \frac{5}{\pi} \sum_{\substack{k=1 \\ \text{odd}}}^{\infty} \left[\frac{\sin 2kt}{k(1+k^2)} - \frac{\cos 2kt}{1+k^2} \right]$$

In obtaining this solution, we have had to use many of the most general concepts introduced in this and the preceding 19 chapters. Some we did not have to use because of the simple nature of this particular circuit, but their places in the general analysis were indicated above. In this sense, we may look upon this problem as the culmination of our introductory study of circuit analysis. In spite of this glorious feeling of accomplishment, however, it must be pointed out that the complete response, as obtained above in analytical form, is not of much value as it stands; it furnishes no clear picture of the nature of the response. What we really need is a sketch of $i(t)$ as a function of time. This may

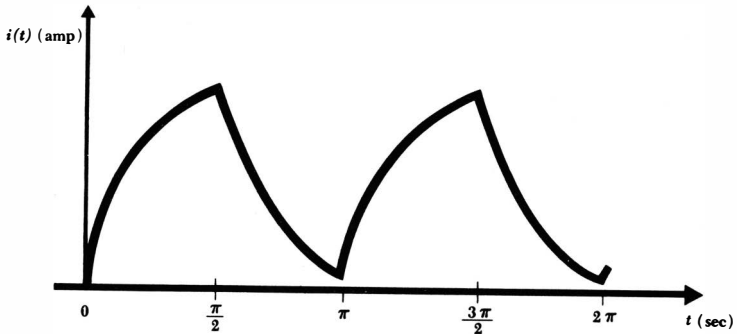

Fig. 20-7 The initial portion of the complete response of the circuit of Fig. 20-6b to the forcing function of Fig. 20-6a.

be obtained by a laborious calculation at a sufficient number of instants of time; an available digital computer can be of great assistance here. It may be approximated by the graphical addition of the natural response, the d-c term, and the first few harmonics; this is an unrewarding task. When all is said and done, the most informative solution of this problem is probably obtained by making a repeated transient analysis. That is, the form of the response can certainly be calculated in the interval from $t = 0$ to $t = \pi/2$ sec; it is an exponential rising toward 2.5 amp. After determining the value at the end of this first interval, we have an initial condition for the next $\frac{1}{2}\pi$ -sec interval. The process is repeated until the response assumes a generally periodic nature. The method is eminently suitable to this example, for there is negligible change in the current waveform in the successive periods $\pi/2 < t < 3\pi/2$ and $3\pi/2 < t < 5\pi/2$. The complete current response is sketched in Fig. 20-7.

20-5 COMPLEX FORM OF THE FOURIER SERIES

In obtaining a frequency spectrum, we have seen that the amplitude of each frequency component depends on both a_k and b_k ; that is, the sine term and the cosine term both contribute to the amplitude. The exact expression for this amplitude is $\sqrt{a_k^2 + b_k^2}$. It is possible to obtain this amplitude directly by using a form of Fourier series in which each term is a cosine function with a phase angle; the amplitude and phase angle are functions of $f(t)$ and k . An even more convenient and concise form of the Fourier series is obtained if the sines and cosines are expressed as exponential functions with complex multiplying constants.

Let us first take the trigonometric form of the Fourier series:

$$f(t) = a_0 + \sum_{n=1}^{\infty} (a_n \cos n\omega_0 t + b_n \sin n\omega_0 t)$$

and then substitute the exponential forms for the sine and cosine. After rearranging,

$$f(t) = a_0 + \sum_{n=1}^{\infty} \left(\epsilon^{jn\omega_0 t} \frac{a_n - jb_n}{2} + \epsilon^{-jn\omega_0 t} \frac{a_n + jb_n}{2} \right)$$

We now define a complex constant c_n :

$$c_n = \frac{1}{2}(a_n - jb_n) \quad (20-25)$$

The values of a_n , b_n , and c_n all depend on n and $f(t)$. Suppose we now replace n by $(-n)$; how do the values of the constants change? The coefficients a_n and b_n are defined by Eqs. (20-10) and (20-11), and it is evident that

$$a_{-n} = a_n$$

but $b_{-n} = -b_n$

From Eq. (20-25), then,

$$c_{-n} = \frac{1}{2}(a_n + jb_n) \quad (20-26)$$

Also

$$c_0 = a_0$$

We may therefore express $f(t)$ as

$$f(t) = c_0 + \sum_{n=1}^{\infty} c_n \epsilon^{jn\omega_0 t} + \sum_{n=1}^{\infty} c_{-n} \epsilon^{-jn\omega_0 t}$$

or
$$f(t) = \sum_{n=0}^{\infty} c_n \epsilon^{jn\omega_0 t} + \sum_{n=1}^{\infty} c_{-n} \epsilon^{-jn\omega_0 t}$$

Finally, instead of summing the second series over the positive integers from 1 to ∞ , let us sum over the negative integers, from -1 to $-\infty$:

$$f(t) = \sum_{n=0}^{\infty} c_n \epsilon^{jn\omega_0 t} + \sum_{n=-1}^{-\infty} c_n \epsilon^{jn\omega_0 t}$$

or
$$f(t) = \sum_{n=-\infty}^{n=\infty} c_n \epsilon^{jn\omega_0 t} \quad (20-27)$$

Equation (20-27) is the complex form of the Fourier series for $f(t)$; its conciseness is one of the most important reasons for its use. In order to obtain the expression by which a particular complex coefficient c_k may be evaluated, we substitute Eqs. (20-10) and (20-11) into Eq. (20-25):

$$c_k = \frac{1}{T} \int_{-T/2}^{T/2} f(t) \cos k\omega_0 t \, dt - j \frac{1}{T} \int_{-T/2}^{T/2} f(t) \sin k\omega_0 t \, dt$$

use the exponential equivalents of the sine and cosine, and simplify:

$$c_k = \frac{1}{T} \int_{-T/2}^{T/2} f(t) \epsilon^{-jk\omega_0 t} \, dt \quad (20-28)$$

Thus, a single concise equation serves to replace the two equations required for

the trigonometric form of the Fourier series. Instead of evaluating two integrals to find the Fourier coefficients, only one integration is required; moreover, it is almost always a simpler integration. It should be noted that the integral (20-28) contains the multiplying factor $1/T$, whereas the integrals for a_n and b_n both contain the factor $2/T$.

Since the amplitude of the Fourier component at a frequency $k\omega_0$ is $\sqrt{a_k^2 + b_k^2}$, the amplitude, expressed in terms of c_k , must be $2|c_k|$. In other words, the magnitude of c_k is equal to one-half the amplitude of the component of the frequency spectrum at the frequency $k\omega_0$.

Let us consider a numerical example to illustrate the use of the complex form of the Fourier series. A train of rectangular pulses E_0 volts in amplitude and τ sec in duration, recurring periodically every T sec, is shown in Fig. 20-8a. The fundamental frequency is, therefore,

$$f_0 = \frac{1}{T}$$

In order to determine the line spectrum of $e(t)$, we shall determine the c_k first and then obtain the corresponding amplitudes of the frequency components by multiplying each $|c_k|$ by 2. The value of a general complex coefficient is first found from Eq. (20-28):

$$\begin{aligned} c_k &= \frac{1}{T} \int_{-T/2}^{T/2} f(t) \epsilon^{-jk\omega_0 t} dt \\ &= \frac{E_0}{T} \int_{t_0}^{t_0+\tau} \epsilon^{-jk\omega_0 t} dt \\ &= \frac{E_0}{-jk\omega_0 T} (\epsilon^{-jk\omega_0(t_0+\tau)} - \epsilon^{-jk\omega_0 t_0}) \\ &= \frac{2E_0}{k\omega_0 T} \epsilon^{-jk\omega_0(t_0+\tau/2)} \sin(\frac{1}{2}k\omega_0\tau) \\ &= \frac{E_0\tau}{T} \frac{\sin(\frac{1}{2}k\omega_0\tau)}{\frac{1}{2}k\omega_0\tau} \epsilon^{-jk\omega_0(t_0+\tau/2)} \end{aligned}$$

The magnitude of c_k is therefore

$$|c_k| = \frac{E_0\tau}{T} \left| \frac{\sin(\frac{1}{2}k\omega_0\tau)}{\frac{1}{2}k\omega_0\tau} \right| \quad (20-29)$$

and the angle of c_k is

$$\text{ang } c_k = -k\omega_0 \left(t_0 + \frac{\tau}{2} \right) \quad (\text{possibly plus } 180^\circ) \quad (20-30)$$

The trigonometric factor in Eq. (20-29) occurs frequently in modern communication theory, and it is called the *sampling function*. Thus, we define

$$Sa(x) = \frac{\sin x}{x}$$

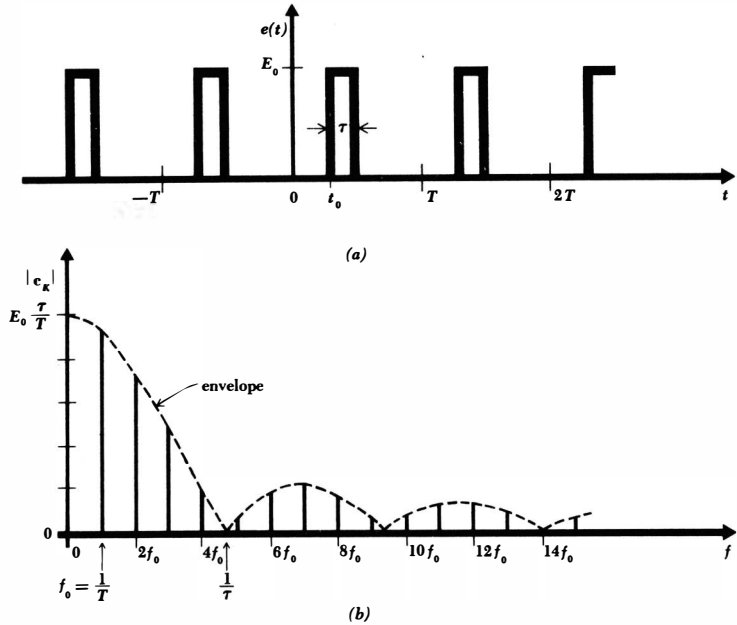

Fig. 20-8 (a) A periodic sequence of rectangular pulses. (b) The corresponding discrete line spectrum.

Because of the way in which it helps to determine the amplitude of the various frequency components in $e(t)$, it is worthwhile discovering the important characteristics of this function. First, we note that $Sa(x)$ is zero whenever x is an integral multiple of π ; that is,

$$Sa(k\pi) = 0 \quad k = 1, 2, 3, \dots$$

When x is zero, the function is indeterminate, but it is easy to show that its value is unity:

$$Sa(0) = 1$$

The magnitude of $Sa(x)$ therefore decreases from unity at $x = 0$ to zero at $x = \pi$. As x increases from π to 2π , $|Sa(x)|$ increases from zero to a maximum less than unity, and then decreases to zero once again. As x continues to increase, the successive maxima continually become smaller because the numerator of $Sa(x)$ cannot exceed unity and the denominator is continually increasing.

Now let us return to the line spectrum of $e(t)$. We may express Eq. (20-29) in terms of the fundamental cyclic frequency f_0 :

$$|c_k| = \frac{E_0\tau}{T} \left| \frac{\sin(k\pi f_0\tau)}{k\pi f_0\tau} \right| \tag{20-31}$$

The amplitude of any harmonic (at a frequency kf_0) is obtained from Eq. (20-31) by using the known values τ and $T = 1/f_0$ and selecting the desired value of k . Instead of evaluating Eq. (20-31) at these discrete frequencies, let us sketch the *envelope* of $|c_k|$ by considering the frequency kf_0 to be a continuous variable. That is, $f(=kf_0)$ can actually take on only the discrete values of the harmonic frequencies $f_0, 2f_0, 3f_0$, and so forth, but we may think of k for the moment as a continuous variable. When f is zero, $|c_k|$ is evidently $E_0\tau/T$, and when f has increased to $1/\tau$, $|c_k|$ is zero. The resultant envelope is sketched as the broken line of Fig. 20-8*b*. The line spectrum is then obtained by simply erecting vertical lines at each harmonic frequency, as shown in the sketch. The amplitudes shown are those of the c_k ; except for the d-c component, the amplitudes of the corresponding sinusoids are twice as great. The particular case sketched applies to the case where $\tau/T = 1/(1.5\pi) = 0.212$. In this example, it happens that there is no harmonic exactly at that frequency at which the envelope amplitude is zero; another choice of τ or T could produce such an occurrence, however.

There are several observations and conclusions which we may make about the line spectrum of a periodic sequence of rectangular pulses. With respect to the envelope of the discrete spectrum, it is evident that the "width" of the envelope depends upon τ , and not upon T . As a matter of fact, the shape of the envelope is not a function of T . It follows that the bandwidth of a filter which is designed to pass the periodic pulses is a function of the pulse width τ , but not of the pulse period T ; an inspection of Fig. 20-8*b* indicates that the required bandwidth is about $1/\tau$ cps. If the pulse period T is increased (or the pulse repetition frequency f_0 is decreased), the bandwidth $1/\tau$ does not change, but the number of spectral lines between zero frequency and $1/\tau$ cps increases in direct proportion to T ; the amplitude of each line is inversely proportional to T . Finally, a shift in the time origin does not change the line spectrum; that is, $|c_k|$ is not a function of t_0 . The relative phases of the frequency components do change with the choice of t_0 .

Drill Problem

20-6 Determine the general coefficient c_k in the complex Fourier series for each of the three waveforms shown in Fig. 20-3.

$$\text{Ans. } \frac{4}{k^2\pi^2} \quad (k \text{ odd}); \frac{-j2}{k\pi} \quad (k \text{ odd}); \frac{2 \sin \frac{1}{2} k\pi}{k\pi}$$

20-6 THE FOURIER INTEGRAL

The spectrum of the periodic rectangular pulses that we just obtained above is a discrete line spectrum. It is the type of spectrum that we must always obtain when we are considering a periodic function of time. However, there are many important forcing functions which are nonperiodic functions of time, such as a single rectangular pulse, a step function, or an impulse. A frequency spec-

trum may also be obtained for such a nonperiodic function, but it will be a *continuous* spectrum in which some energy may in general be found in any frequency interval, no matter how small. We shall develop this concept by beginning with a periodic function and then letting the period become infinite. Our experience with the periodic rectangular pulses indicates that the envelope will decrease in amplitude, but otherwise not change shape, and that more and more frequency components will be found in any given frequency interval. In the limit, we should expect an envelope of vanishingly small amplitude filled with an infinite number of frequency components separated by vanishingly small frequency intervals. The number of frequency components between, say, zero and 100 cps becomes infinite, but the amplitude of each one approaches zero. A spectrum of zero amplitude is a difficult concept, both analytically and graphically, and it is logical that we cause the envelope to have a finite amplitude by increasing the spectrum amplitude as the period increases. Whereas the line spectrum of a periodic voltage waveform shows the voltage of each frequency component, the continuous spectrum is a plot of the voltage per unit bandwidth as a function of frequency. Let us now carry out this limiting procedure.

We begin with the exponential form of the Fourier series (20-27):

$$f(t) = \sum_{n=-\infty}^{n=\infty} c_n e^{jn\omega_0 t} \quad (20-32)$$

where

$$c_n = \frac{1}{T} \int_{-T/2}^{T/2} f(t) e^{-jn\omega_0 t} dt \quad (20-33)$$

and $\omega_0 = \frac{2\pi}{T}$ (20-34)

We now let

$$T \rightarrow \infty \quad (20-35)$$

and thus, from Eq. (20-34), ω_0 must become vanishingly small. We represent this limit by a differential

$$\omega_0 \rightarrow d\omega \quad (20-36)$$

Thus

$$\frac{1}{T} = \frac{\omega_0}{2\pi} \rightarrow \frac{d\omega}{2\pi} \quad (20-37)$$

Finally, the frequency of any "harmonic" $n\omega_0$ must now correspond to the general frequency variable which describes the continuous spectrum. In other words, n must tend to infinity as ω_0 approaches zero, such that the product is finite:

$$n\omega_0 \rightarrow \omega \quad (20-38)$$

When these four limiting operations are applied to Eq. (20-33), we find that c_n

621 Fourier Analysis

must approach zero, as we had previously presumed. If we multiply each side of Eq. (20-33) by the period T and then undertake the limiting process, a non-trivial result is obtained:

$$c_n T \rightarrow \int_{-\infty}^{\infty} f(t) \epsilon^{-j\omega t} dt$$

The right side of this expression is a function of ω (and *not* of t), and we represent it by $F(j\omega)$:

$$F(j\omega) = \int_{-\infty}^{\infty} f(t) \epsilon^{-j\omega t} dt \tag{20-39}$$

In order to apply the limiting process to Eq. (20-32), we multiply and divide the summation by T ,

$$f(t) = \sum_{n=-\infty}^{n=\infty} c_n T \epsilon^{jm\omega_0 t} \frac{1}{T}$$

and use Eqs. (20-37), (20-38), and the new quantity $F(j\omega)$. In the limit, the summation becomes an integral, and

$$f(t) = \frac{1}{2\pi} \int_{-\infty}^{\infty} F(j\omega) \epsilon^{j\omega t} d\omega \tag{20-40}$$

Equations (20-39) and (20-40) are collectively called the *Fourier transform pair*. The function $F(j\omega)$ is the *Fourier transform* of $f(t)$, and $f(t)$ is the *inverse* Fourier transform of $F(j\omega)$.

Let us use the Fourier transform to obtain the continuous spectrum of a single rectangular pulse. We shall select that pulse in Fig. 20-8a which occurs in the interval $t_0 < t < t_0 + \tau$. Thus

$$f(t) = \begin{cases} E_0 & t_0 < t < t_0 + \tau \\ 0 & t < t_0 \text{ and } t > t_0 + \tau \end{cases}$$

The Fourier transform of $f(t)$ is found from Eq. (20-39):

$$F(j\omega) = \int_{t_0}^{t_0+\tau} E_0 \epsilon^{-j\omega t} dt$$

and this may be easily integrated and simplified:

$$F(j\omega) = E_0 \tau \frac{\sin \frac{1}{2}\omega\tau}{\frac{1}{2}\omega\tau} \epsilon^{-j\omega(t_0+\tau/2)}$$

The magnitude of $F(j\omega)$ yields the continuous frequency spectrum, and it is obviously of the form of the sampling function. The value of $F(0)$ is $E_0\tau$. The shape of the spectrum is identical with the broken-line curve of Fig. 20-8b. A plot of $|F(j\omega)|$ as a function of ω does *not* indicate the magnitude of the voltage present at any given frequency; the magnitude of the component at a specific frequency is zero. Instead, the limiting process we followed in defining $F(j\omega)$ shows that the voltage present in an incremental frequency band $\Delta\omega$ is $F(j\omega) \Delta\omega$.

20-7 OPERATIONAL METHODS OF CIRCUIT ANALYSIS

The introduction of the Fourier transform in the preceding section is perhaps the first step in the process of developing what are known as “operational methods” of circuit analysis. These methods are very powerful and very general, and they are based on more advanced mathematical techniques than those which we have probably already learned. This introductory study of the methods of circuit analysis is intended to bring us up to the point where operational methods may be advantageously introduced. Since their applicability is so broad, there is a tendency to apply them to every problem, no matter how simple. This is an unfortunate situation, if it occurs, for much time may be wasted in obtaining a response which we should feel is obvious to us now. The majority of the circuits with which we shall deal as undergraduates are of a nature which is sufficiently simple that operational methods offer few advantages.

The advantages inherent in operational methods become of increasing importance as our scientific maturity increases. Their use serves to systematize the determination of the complete response and, in particular, the use of the initial conditions. This is particularly important for networks having greater complexity. Several areas of more advanced study, such as the synthesis of networks to meet prescribed characteristics, the investigation of network response to noise, and the determination of stability in feedback systems, are based upon operational methods.

One of the common methods of introducing operational methods is through the extension of the Fourier integral and Fourier transform. Instead of relating a real function of time and a complex function of $j\omega$, the transform concept is extended to provide a relationship between $f(t)$ and $F(s)$. The result is the *Laplace transform*. In a sense, a frequency spectrum of a forcing function or a response is obtained for the complex frequency s . Many nonperiodic functions of time which do not possess a Fourier transform can be expressed as a Laplace transform. They are thus transformed from the time domain to the frequency domain, and most of our frequency-domain techniques will still be applicable.

Problems

- ◆1 Determine the Fourier series for a 1-amp rectangular current pulse extending from $t = -a/2$ to $t = a/2$. Let the period be T , where $a < T$.
- 2 In Prob. 1, let $T = 1$ sec and find the value or values for a which will produce the largest-amplitude 5-cps component.
- ◆3 Write the Fourier series for the sawtooth voltage waveform shown in Fig. 20-9a.
- 4 (a) Obtain the Fourier series for the triangular current waveform shown in Fig. 20-9b. (b) Check the answer by evaluating the series numerically at $t = \pi/2$, using first the first three terms and then the first ten terms.
- ◆5 (a) Determine the Fourier series for the full-wave rectifier output voltage

shown in Fig. 20-10a. (b) This voltage is applied to a 1000-ohm load resistor through a simple RC filter, as shown in Fig. 20-10b. Determine C in order that the amplitude of the fundamental voltage across the load is only 1 per cent of the d-c load voltage.

- 6 The current waveform of Fig. 20-3a is applied to a bandpass filter which has unity gain within the passband and zero gain outside the passband. A 10-ohm resistor is connected to the output of the filter. Find the average power delivered to the resistor if the passband extends from: (a) $f = 0$ to $f = 0.8$ cps; (b) $f = 2$ to $f = 3$ cps; (c) $f = 0$ to $f = 3$ cps; (d) $f = 0$ to $f = \infty$.
- 7 (a) Write the Fourier series for $e_s(t)$, as plotted in Fig. 20-11a. (b) If this voltage waveform is used as the forcing function in the series circuit of Fig. 20-11b, make some reasonable approximations and find $i(t)$.
- 8 Determine the Fourier series for the infinite sequence of voltage impulses shown in Fig. 20-12a.
- 9 (a) In general, one can show that the Fourier series for $df(t)/dt$ may be obtained by term-by-term differentiation of the Fourier series for $f(t)$ if the resultant series converges. Graphically determine the derivative of the current waveform of Prob. 4, and then obtain the Fourier series of this new periodic function. Show that the resultant series is equal to the derivative of the series obtained in Prob. 4. (b) The Fourier series for $\int f(t) dt$ may always

Fig. 20-9 (a) See Prob. 3. (b) See Prob. 4.

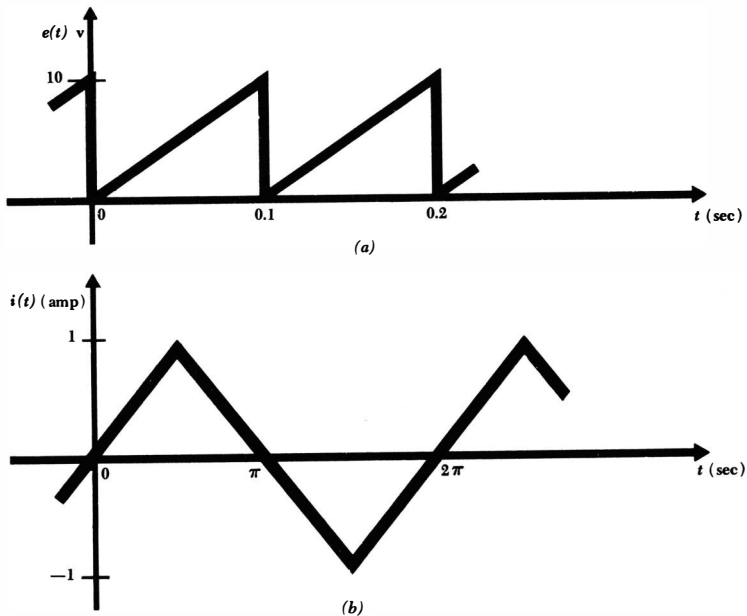

624 *Special Topics*

be obtained by term-by-term integration of the Fourier series for $f(t)$; however, if $f(t)$ contains a d-c component, then the integral of $f(t)$ and the integrated series are both rather meaningless. Show that the Fourier series of the integral of the current waveform shown in Fig. 20-3b is identical with the integral of the Fourier series of that waveform.

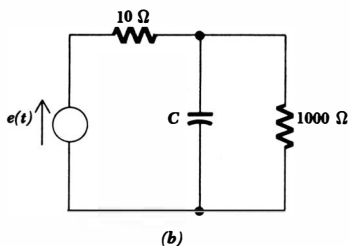
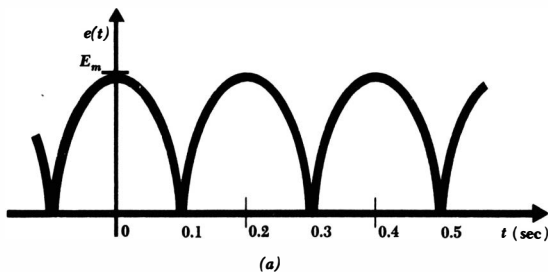

Fig. 20-10 See Prob. 5.

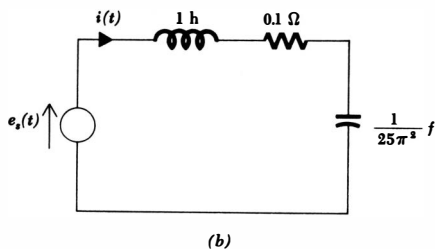
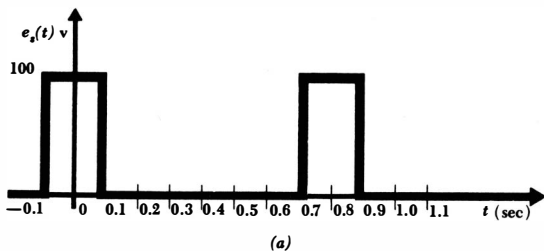

Fig. 20-11 See Prob. 7.

- 10 Find the Fourier series of $f(t)$ if $f(t) = 3 \cos^2 2t$ between $t = 0$ and $t = \pi$ sec, and the function then repeats.
- 11 In the interval from $t = 0$ to $t = 0.2$, $f(t)$ is defined by the sketch of Fig. 20-12b. (a) Define $f(t)$ in the interval from $t = -0.2$ to $t = 0$ so that $f(t)$ is an even function with a period of 0.4 sec, and determine its Fourier series. (b) Define $f(t)$ in the interval from $t = -0.2$ to $t = 0$ so that $f(t)$ is an odd function with a period of 0.4 sec, and determine its Fourier series. (c) Define $f(t)$ in the interval from $t = 0.2$ to $t = 0.8$ sec so that $f(t)$ is an even function with half-wave symmetry with a period of 0.8 sec, and determine its Fourier series.
- 12 Determine whether the following functions are even, odd, or neither:
 - ♦(a) $1/(1 + t^2)$; ♦(b) $(\sin \pi t)/t$; ♦(c) $|t|$; (d) $1 + t$; (e) $1/(1 + t) + 1/(1 - t)$; (f) e^{-5t} ; (g) $u(t)$.
- 13 After determining the symmetry involved, express $f(t)$ in a Fourier series if:
 - (a) $f(t) = -2, -10 < t < -5$; $f(t) = -1, -5 < t < 0$; $f(t) = 1, 0 < t < 5$; $f(t) = 2, 5 < t < 10$; $T = 20$.
 - (b) $f(t) = \cos t, 0 < t < \pi/2$; $f(t) = -\sin t, \pi/2 < t < \pi$; $T = \pi$.
 - (c) $f(t)$ is the function shown in Fig. 20-13.

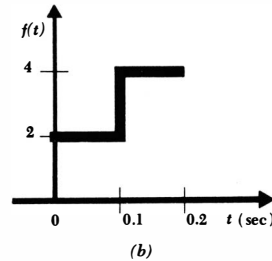
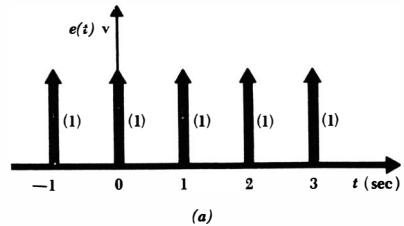

Fig. 20-12 (a) See Prob. 8. (b) See Prob. 11.

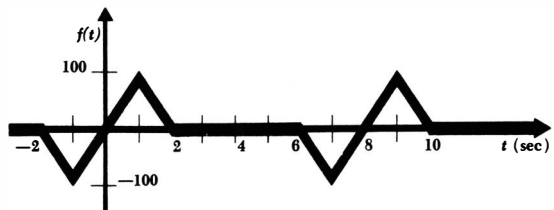

Fig. 20-13 See Prob. 13.

- ◆14 Although the waveform shown in Fig. 20-14a does not possess either even or odd symmetry, the simplifications provided by odd symmetry may be used if the d-c component of the waveform is first determined and then subtracted from the waveform. Determine the Fourier series of $e(t)$ by this method.
- 15 Identify the location of the time origin on the waveform shown in Fig. 20-14b if the Fourier series is to contain only: (a) odd-harmonic sine terms; (b) odd-harmonic cosine terms.
- 16 A Fourier series may be obtained for a waveform by numerical methods when an analytical expression for $f(t)$ is not known or is unwieldy. The integral for a_k ,

$$a_k = \frac{2}{T} \int_0^T f(t) \cos k\omega_0 t \, dt$$

may be expressed as an approximate sum by subdividing the interval of integration into M equal parts:

$$a_k = \frac{2}{T} \sum_{m=1}^M f(t_m) \cos k\omega_0 t_m \frac{T}{M} = \frac{2}{M} \sum_{m=1}^M f(t_m) \cos k\omega_0 t_m$$

The value of $f(t_m)$ and $\cos k\omega_0 t_m$ may be determined at the mid-point of each interval. A similar summation is used to evaluate b_k . By dividing the period into 20 equal parts, find the approximate amplitude of the 1-cps component of the waveform described by: $f(t) = \sqrt{t}$, $0 \leq t \leq 1$; $f(t) = \sqrt{2-t}$, $1 \leq t \leq 2$; $T = 2$. The exact answer to two significant figures is -0.053 .

- ◆17 A current source, a closed switch, a 2-ohm resistor, and a 0.5-farad capacitor are in parallel. The waveform of the current source is sketched in Fig. 20-3b. The switch is opened at $t = 0$, and the capacitor voltage is the desired response. (a) Work in the frequency domain of the k th harmonic to find the

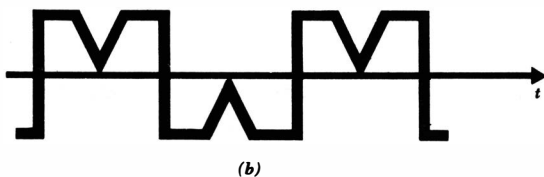
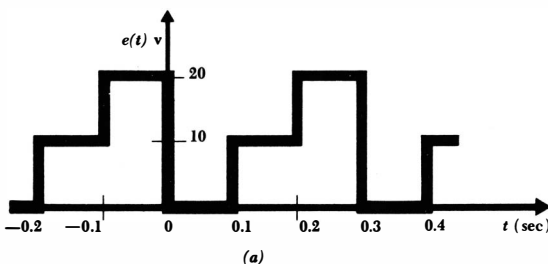
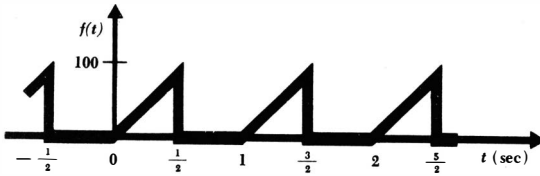
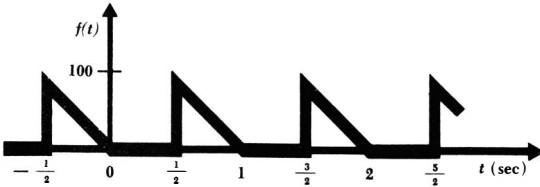

Fig. 20-14 (a) See Prob. 14. (b) See Prob. 15.



(a)



(b)

Fig. 20-15 (a) See Prob. 24. (b) See Prob. 25.

- forced response to this component. Express the total forced response as a trigonometric Fourier series. (b) Specify the functional form of the natural response. (c) Determine the complete response.
- 18 Find the complete response of the circuit described in Prob. 17 by considering the input as a sequence of suitable unit-step forcing functions. The response is to be determined and plotted over an interval which represents two periods of the forcing function.
- ◆19 A square-wave voltage forcing function having no d-c component is applied to a series *RLC* circuit. The output voltage is taken across the capacitor. Determine the resonant frequency and the Q_0 of the *RLC* circuit if the output is to be essentially a 100-kc sinusoid. Assume that no other frequency component of the output may have an amplitude greater than 1 per cent of the desired component. The period of the square wave is 250 μ sec.
- 20 An amplitude-modulated wave is expressed by the periodic function $e(t) = E_0(1 + m \cos \omega_m t) \cos \omega_c t$, where ω_c is the carrier (high) frequency, ω_m is the modulating (signal) frequency, E_0 is the unmodulated carrier amplitude, and $100m$ per cent is the percentage of modulation. Let $E_0 = 1$ volt, $m = 0.5$, $\omega_m = 1$ radian/sec, and $\omega_c = 10$ radians/sec. (a) Express $e(t)$ as a Fourier series. (b) Find the average power delivered by the unmodulated ($m = 0$) wave to a 2-ohm resistor. (c) Find the average power delivered by the modulated wave to the same resistor.
- ◆21 A certain amateur radio station radiates a sinusoidal 15-mcs signal when the "key" is depressed, and is quiescent when the key is up. Assume that the operator periodically depresses the key for 0.1 sec and then releases it for 0.1 sec. (a) Can the radiated signal cause interference with another signal occupying the band from 15.061 to 15.062 mc? (b) Does the modulated wave have a frequency component at the keying frequency (5 cps)?
- 22 Determine the complex Fourier series of the sequence of impulses shown in Fig. 20-12a.

628 *Special Topics*

- 23** Show that $Sa(0) = 1$.
- 24** ♦(a) Determine the complex Fourier series for the sawtooth waveform of Fig. 20-15a. (b) Sketch the frequency spectrum of this waveform. (c) Convert the series to trigonometric form.
- 25** Repeat Prob. 24 for the waveform shown in Fig. 20-15b.
- 26** Obtain the Fourier transform $\mathbf{F}(j\omega)$ and plot $|\mathbf{F}(j\omega)|$ versus ω for the single pulse described by: (a) $f(t) = \cos 2\pi t, -0.25 < t < 0.25$; (b) $f(t) = \cos 2\pi t, -0.5 < t < 0.5$; (c) $f(t) = \cos 2\pi t, -1 < t < 1$; (d) $f(t) = 1 + t, -1 < t < 0$; $f(t) = 1 - t, 0 < t < 1$; (e) $f(t) = \delta(t)$.

Answers

Chapter 1 ♦ (1) $[ML^2T^{-2}]$, $[T^{-1}]$, $[T^{-2}]$, $[MLT^{-1}]$. (3) $-3t^2 + 14t - 11$ amp. (5) 1.685 coulombs. (6) (a) 292.5 coulombs. (b) -1 amp. (9) 4 watts, active. (12) (a) 3×10^{-4} watt, 3 watts, 30 kw.

Chapter 2 ♦ (1) (a) 1.005 ohms, 1.51°C , 0.01 watt. (b) 2 ohms, 300°C , 2 watts. (c) 1.414 amp. (d) 1.366 ohms, 109.8°C , 0.732 watt. (e) 7.59 ohms, 1977°C , 13.18 watts. (3) 4 ohms. (6) 2 watts. (8) (a) $\frac{3}{11}$ mho. (b) From left to right: 6 amp, 1 volt; 3 amp, 1 volt; 9 amp, 10 volts; 3 amp, 11 volts; 12 amp, 11 volts. (c) 6 watts, 3 watts, 90 watts, 33 watts, -132 watts. (10) (a) 0.933 ohm. (b) 0.733. (c) 0.02, 0.06. (d) 11.9 volts. (12) (a) Powers are: 0.5 watt, -5 watts, 1.25 watts, 2.5 watts, 0.75 watt. (b) All currents and voltages double, all powers quadruple. (c) Voltages are unchanged, all currents halved, all powers halved. (14) (a) Powers are: 72 watts, 16 watts, -120 watts, 32 watts. (b) Absorbing power; $R = 18$ ohms, $e_s = 36$ volts, $i_s = 2$ amp. (c) Powers are: -168 watts, 16 watts, 120 watts, 32 watts, furnishing power, $e_s = 84$ volts, $i_s = 2$ amp. (16) (a) 0.98 watt, 8.26 watts, 22.2 watts, 25 watts, 22.2 watts, 8.26 watts, $10,000R_1/(100 + R_1)^2$ watts. (b) 100 ohms. (c) No. (d) Yes. (e) R_s ohms. (17) Powers are: 72 watts, -240 watts, 48 watts, 120 watts, 24 watts, -24 watts. (19) (a) 2. (b) 10 volts. (c) 30 watts. (d) 100 watts. (e) -100 watts. (f) 2 amp. (22) (a) $5\frac{9}{8} \cos t$ volts. (b) 3.6 volts. (24) (a) 12 ohms. (b) 0.5 mho. (26) 16.18 ohms. (28) 1 amp, 1 amp, 20 watts. (30) 13.33 volts, 6.67 amp, 88.9 watts. (32) 1.042 watts. (35) 3 ohms. (37) (a) -150 volts, -5 amp, 0 volts, 5 amp, 150 volts, 0 amp. (b) -30 volts, -1 amp, 120 volts, 5 amp, 150 volts, 4 amp.

Chapter 3 ♦ (1) (c) See Fig. 1; 5 meshes. (3) 10 ohms. (5) 1.182 amp. (6) (a) -18 . (b) 256. (c) -2 . (d) 32. (8) (a) 0 amp. (b) $-0.0625(\sin t + \cos t)$ amp. (11) 5.22 volts. (13) 27 watts. (15) (a) $i_{\text{load}} = 83$ amp, $i_{\text{mid}} = 63.5$ amp discharging, $i_{\text{bottom}} = 19.5$ amp discharging. (b) 206.7 watts, 310 watts. (17) -4 watts, 2 watts, 2 watts, 0 watts, 0 watts. (19) (a) $\frac{1}{15}$ mho. (b) Impossible. (21) (a) 2 amp, 5 volts, 2.5 ohms. (b) 15 amp, 36 volts, 2.4 ohms. (c) 5 amp, 10 volts, 2 ohms. (d) 5 amp, 25 volts, 5 ohms. (23) 1.89 watts. (27) 75 volts, 1.5 amp, 50 ohms. (29) 320 watts. (31) (a) 3 volts. (b) -12 volts. (c) 12 ohms in series with input; 4 ohms in parallel with output. (33) 20 watts or 180 watts. (35) 2.68 msec. (37) 10 volts. (39) 12 volts, 3 amp, 4 ohms. (41)

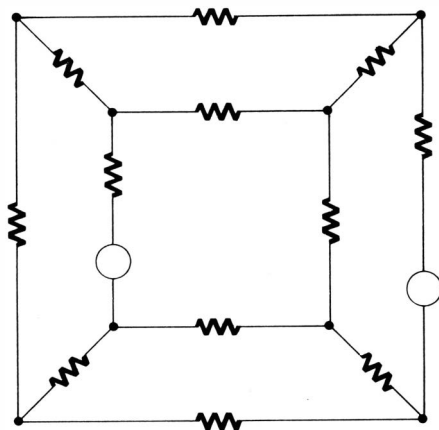

Fig. 1

20 watts. (44) (a) $i_{s2} + e_{s1}/R_1$ amp, R_1 ohms. (b) 15 amp, 5 ohms. (c) $-\mu e_g/r_p$ amp, r_p ohms. (48) $2\frac{2}{3}$ amp, $2\frac{2}{3}$ volts.

- Chapter 4** ♦ (2) (a) 0.01 sec, 2.5 joules. (b) 500 μ sec or greater, 62.5 mjoules. (4) 2.5 amp, 2.5 amp, 1.25 amp. (5) (a) 1 amp. (b) 1 amp. (c) 2 amp. (8) (a) Between 1 and 3 msec, 2.5 mjoules. (b) 1 msec or greater, 5 mjoules. (10) 50 volts, 30 volts, 30 volts. (11) (a) 20 volts. (b) 20 volts. (c) 7.5 volts. (14) (a) $10 \cos(t/4)$ volts. (b) $-10 \cos(t/4)$ volts. (c) 0 volts. (17) (a) $L_x = L_s$, $i_x(t) = \frac{1}{L_s} \int e_s dt + k$. (b) $C_x = C_s$, $i_x = C_s \frac{de_s}{dt}$. (20) $-135e^{-3t}$ volts. (21) $-72 \sin 3t$ amp. (24) 6 volts. (27) $i_1 R_1 + \frac{1}{C_1} \int_{t_0}^t (i_1 - i_3) dt + e_{C1}(t_0) + L_2 \frac{d(i_1 - i_2)}{dt} = e_1$, $L_2 \frac{d(i_2 - i_1)}{dt} + \frac{1}{C_2} \int_{t_0}^t (i_2 - i_3) dt + e_{C2}(t_0) + i_2 R_s = -e_2$, $\frac{1}{C_1} \int_{t_0}^t (i_3 - i_1) dt + e_{C1}(t_0) + L_1 \frac{di_3}{dt} + \frac{1}{C_2} \int_{t_0}^t (i_3 - i_2) dt + e_{C2}(t_0) = 0$. (29) (a) $L_2/(L_1 + L_2)$. (b) $C_1/(C_1 + C_2)$. (30) (a) $L_1/(L_1 + L_2)$. (b) $C_2/(C_1 + C_2)$. (31) (a) and (b) See Fig. 2. (35) (a) See Fig. 3a; yes, if $L = C$. (b) See Fig. 3b; no, there is source polarity trouble. (37) e^{-t} amp, $0.5e^t + 0.5e^{-t} = \cosh t$ amp, $-0.5e^t + 0.5e^{-t} = -\sinh t$ amp. (39) $\cos 3t$ volts, $-2.5 \cos 3t$ volts; $3.5 \cos 3t$ volts.

- Chapter 5** ♦ (1) (a) 10 volts. (b) 4.72 volts. (c) 0.821 volt. (3) 0.550 sec. (5) $10e^{-2(t-1)}$ amp, $t \geq 1$. (8) 12 amp, $12e^{-1.333t}$ amp, $3.17e^{-0.667t}$ amp. (10) 5.77 sec. (12) About 4.4 henrys, 20 ohms; upper curve is coil

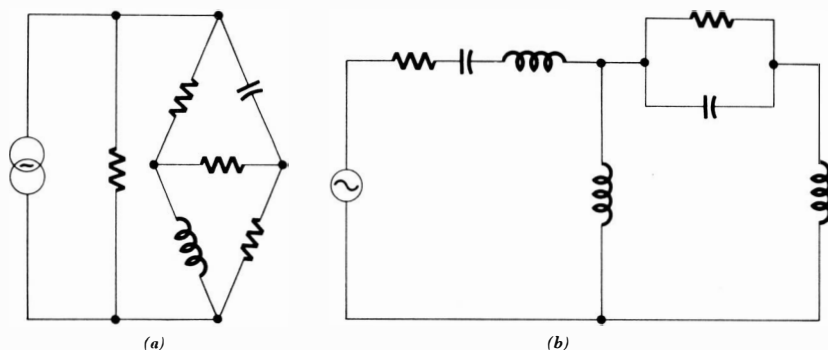

Fig. 2

alone. (15) $-2.4\epsilon^{-2.5t}$ amp. (It is necessary to assume that the switch is a better approximation to a short circuit than the source is to an ideal source.) (16) For $t < 0$, $i_1(t) = 5.10$ amp, $i_2(t) = 3.06$ amp, $i_3(t) = 2.04$ amp. For $t > 0$, $i_1(t) = 5.10\epsilon^{-1.56t}$ amp, $i_2(t) = 3.06\epsilon^{-1.56t}$ amp, $i_3(t) = 2.04\epsilon^{-1.56t}$ amp. (19) (a) 12 ma. (b) 75 μ sec. (c) $0.012\epsilon^{-t/75 \times 10^{-6}}$ amp. (d) $0.004(1 + \epsilon^{-t/75 \times 10^{-6}})$ amp. (e) $0.008\epsilon^{-t/75 \times 10^{-6}} - 0.004$ amp. (f) 0 amp. (g) 4 ma. (h) -4 ma. (21) (a) $100\epsilon^{-106t}$ volts. (b) $200\epsilon^{-200,000t}$ volts. (c) $-1000\epsilon^{-5000t}$ volts. (23) (a) 100 volts. (b) 54.9 volts. (c) 16.5 volts. (26) $75\epsilon^{-t/6 \times 10^{-6}}$ volts. (28) $i_{R1}(t) = 10\epsilon^{-t/50}$ amp, $i_{R2}(t) = -10\epsilon^{-t/50}$ amp. (30) For $t < 0$, $e_1 = 24$ volts, $e_2 = -4$ volts, $e_x = -16$ volts. For $t > 0$, $e_1(t) = 24\epsilon^{-23t/3}$ volts, $e_2(t) = 14.4\epsilon^{-23t/3}$ volts, $e_x(t) = -16\epsilon^{-23t/3}$ volts. (32) (a) $i_A = -4\epsilon^{-t/2} + 5\epsilon^{-t}$ amp. (b) Maximum i_A is 1 amp and occurs at $t = 0$. Therefore i_A never exceeds 1 amp. (34) (a) $3\epsilon^{-t/2}$ amp. (b) 11.4 joules.

Chapter 6 ♦ (2) See Fig. 4. (4) $2(1 - \epsilon^{-1000t})u(t)$ amp. (6) (a) $Cde/dt + ke^2 = 0$.

(b) $e = \frac{1}{\frac{1}{e_0} + \frac{kt}{C}}$ volts. (8) (a) $1 + 2kL de/dt = 0$. (b) $e = e_0 - \frac{t}{2kL}$ volts.

(10) $i(t) = (90 - 30\epsilon^{-t/2})u(t)$ amp. (11) $i(t) = (5 - 3.33\epsilon^{-0.667t})u(t)$

Fig. 3

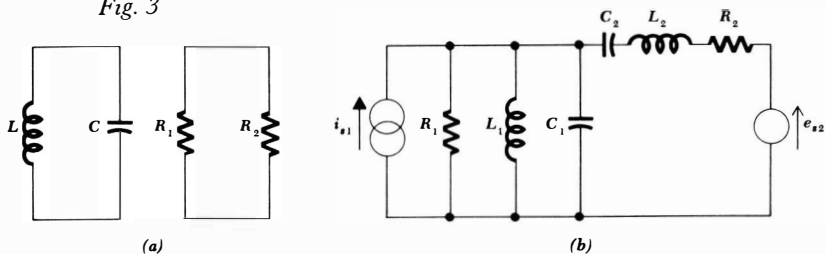

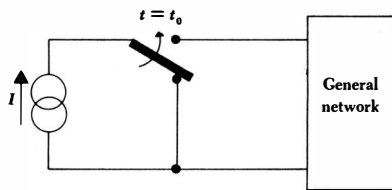

Fig. 4

amp. (14) For $t < 0$, $i(t) = 100\%$ amp. For $t > 0$, $i(t) = 25 + 8.33\epsilon^{-2t}$ amp. (16) $i_1(t) = 4.21\epsilon^{-t/3.1}u(t)$ amp, $i_2(t) = 2.81\epsilon^{-t/3.1}u(t)$ amp. (18) $(-1.33 + 1.11\epsilon^{-t})u(t)$ volts. (21) (a) $0.01\epsilon^{-10^6t}u(t)$ amp. (b) $0.001\epsilon^{-10^6t}u(t)$ amp. (23) $75 - 25(1 - \epsilon^{-t/0.6})u(t)$. (26) For $t \leq 1$, $e_C(t) = 1000(1 - \epsilon^{-t})u(t)$ volts; for $t \geq 1$, $e_C(t) = 500 + 132\epsilon^{-(t-1)}$ volts. (28) $e(t) = 300(1 - \epsilon^{-t/20})u(t)$ volts, $i(t) = 75\epsilon^{-t/20}u(t)$ amp. (30) For $t \leq 1$, $e_C = 10(1 - \epsilon^{-t})u(t)$ volts; for $t \geq 1$, $e_C = 6.32\epsilon^{-(t-1)}$ volts. (33) 58.9 volts.

Chapter 7 ♦ (2) (a) 1. (b) 0.966. (c) 0. (d) 5. (e) 1.273. (4) $2.4\delta(t) + 1.2u(t)$ amp. (8) $-20\delta(t - 4) - 5u(t - 4)$ amp.

$$(10) e_1 = \frac{L_1\lambda_0}{L_1 + L_2} \delta(t) \text{ volts}, e_2 = \frac{L_2\lambda_0}{L_1 + L_2} \delta(t) \text{ volts.}$$

(13) (a) $\delta(t) + 10^{-6}d(t)$ volts. (b) $\delta(t) + 10^{-6}d(t) + 100u(t)$ volts.

(14) (a) $10^{-3}\delta(t) + 10^5u(t)$ amp. (b) $10^{-3}\delta(t) + 10^5u(t) + 10^{-6}d(t)$

amp. (15) (a) See Fig. 5a; i , e_R , e_C same for $t > 0$. (b) See Fig. 5b;

i_C , e_C same for $t > 0$. (19) (a) $2u(t)$ amp. (b) $2(1 - \epsilon^{-5t})u(t)$ amp.

(c) $(2 - 0.5\epsilon^{-5t})u(t)$ amp. (d) $(2 - 0.1875\epsilon^{-15t/8})u(t)$ amp.

$$(22) i(t) = \frac{\lambda_0}{R} \delta(t) - \frac{\lambda_0}{R^2C} \epsilon^{-t/RC}u(t) \text{ amp, } e_R(t) =$$

$$\lambda_0\delta(t) - \frac{\lambda_0}{RC} \epsilon^{-t/RC}u(t) \text{ volts, } e_C(t) = \frac{\lambda_0}{RC} \epsilon^{-t/RC}u(t) \text{ volts.}$$

Chapter 8 ♦ (2) (a) $63.3(\epsilon^{-0.879t} - \epsilon^{-34.1t})$ volts. (b) $60\epsilon^{-0.857t}$ volts. (4) (a)

0.0833 ohm. (b) 39.1 joules. (5) (a) $-40.2\epsilon^{-0.268t} + 0.21\epsilon^{-3.73t}$ amp.

(b) $-20\epsilon^{-t}(1 + 0.5t)$ amp. (7) (a) 667 ohms. (b) $10^6t\epsilon^{-10^5t}$ volts.

Fig. 5

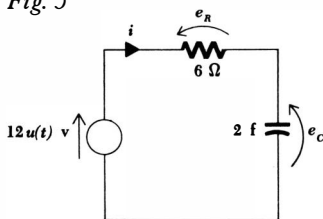

(a)

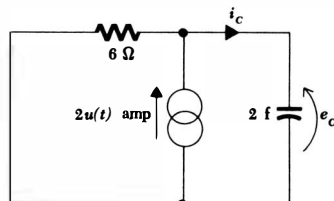

(b)

(c) No in both cases. (9) $60\epsilon^{-5t} \cos 10t$ volts. (11) (a) $2 \sin 10^6 t$ amp. (b) $100 \cos 10^6 t$ volts. (c) $w(t) = 10^{-4}$ joule; constant; no losses. (13) $i(t) = 1.775\epsilon^{-t/4} \sin 2.82t$ amp, 3.12 joules. (15) 9:03.00000359 A.M.; 8.50 ma. (17) (a) $s_1 = -2000, s_2 = -8000, i(t) = 4(\epsilon^{-2000t} - \epsilon^{-8000t})$ amp. (b) 2.31×10^{-4} sec. (c) $w_L(0) = 0$ joules, $w_C(0) = 0.18$ joule, $w_L(t_m) = 0.0178$ joule, $w_C(t_m) = 0.111$ joule. (d) 2.68 msec. (19) $18\epsilon^{-t} - 8\epsilon^{-6t}$ amp. (21) $\alpha = 1000, \omega_0^2 = 4.01 \times 10^8, \omega_d = 20,000, i(t) = 0.01\epsilon^{-1000t} \sin 20,000t$ amp. (23) $\epsilon^{-0.0625t}(-10 \cos 5t - 0.125 \sin 5t)$ amp. (25) $10\epsilon^{-0.1t} \sin 0.3t$ amp. (29) $50 - 35\epsilon^{-t} - 15\epsilon^{-3t}$ volts. (32) $20 + \epsilon^{-3t}(30 \cos t + 90 \sin t)u(t)$ volts. (34) $e_2(t) = 500\epsilon^{-20t}u(t)$ volts, $e_1(t) = 30d(t) + 500\epsilon^{-20t}u(t)$ volts. (37) (a) 2.24 radians/sec. (b) $v(t) = -0.447 \sin \sqrt{5} t$ m/sec, $x(t) = 1.96 + 0.2 \cos \sqrt{5} t$ m.

Chapter 9 ♦ (1) $T = 7.4 \mu\text{sec}, f = 135 \text{ kc}, \omega = 0.848 \times 10^6$ radians/sec, $e(t) = 20 \cos(0.848 \times 10^6 t - 55.9^\circ) = 20 \sin(0.848 \times 10^6 t + 34.1^\circ) = 11.2 \cos 0.848 \times 10^6 t + 16.6 \sin 0.848 \times 10^6 t$ volts, -153.1° . (3) $e(t) = 2 \cos(500\pi t - 135^\circ)$ volts, $i(t) = \cos(500\pi t - 180^\circ)$ amp, $R = 1.414$ ohms, $L = 0.899$ mh. (4) (a) $0.6 \cos 200t + 0.8 \sin 200t$ amp. (b) $\cos(200t - 53.1^\circ)$ amp. (c) $\sin(200t + 36.9^\circ)$ amp. (e) $e_R = 30 \cos(200t - 53.1^\circ)$ volts. (f) $e_L = 40 \cos(200t + 36.9^\circ)$ volts. (7) 0.760 amp, 20.6° . (9) $i(t) = 1.08 \cos 2t + 1.44 \sin 2t - 1.08\epsilon^{-1.5t}$ amp, $e_L(t) = 7.20 \cos(2t + 36.9^\circ) + 3.24\epsilon^{-1.5t}$ volts.

Chapter 10 ♦ (1) $-1, j1, 1$. (2) (a) 5.38, 68.2° ; 3.61, 213.7° ; 101.1, 8.52° . (b) $-7.07, 7.07$; 0.05, -0.0866 ; $-3.83, 3.21$. (6) (a) $-2 - j2$. (b) $-4 + j0$. (c) $0.24 + j0$. (d) $-10 + j0$. (8) (a) $j \sinh x = j \frac{1}{2}(\epsilon^x - \epsilon^{-x}) = \frac{1}{j2}(\epsilon^x - \epsilon^{-x}) = \frac{1}{j2}(\epsilon^{j(jx)} - \epsilon^{-j(jx)}) = \sin jx$. (b) $\cosh x = \frac{1}{2}(\epsilon^x + \epsilon^{-x}) = \frac{1}{2}(\epsilon^{-j(jx)} + \epsilon^{j(jx)}) = \cos jx$. (10) (a) 0.995 + $j0.0998$. (11) (a) $1.103 - j0.501$. (12) (b) $5.10\epsilon^{j78.7^\circ}$. (13) (a) $65.5 + j45.9$. (14) (a) $4.13/\underline{-14.0^\circ}$. (b) $2.22/\underline{58.0^\circ}$. (c) $1.16/\underline{-143^\circ}$. (d) $2/\underline{0^\circ}$. (e) $-5.20 + j3$. (f) $9 - j7$. (g) $-8.71 - j2.08$. (h) $j1.333$. (i) $-0.8 + j0.6$. (j) $6 + j0$. (k) $j4$. (l) $13 + j0$. (m) $13/\underline{-67.4^\circ}$. (n) $6.12/\underline{0^\circ}$. (o) $1.39/\underline{146.2^\circ}$. (18) $1.707 + j1.707$, or $0.293 + j0.293$. (19) (a) $13/\underline{67.4^\circ}$. (b) $44.5 + j252$. (c) j . (d) $-0.174 \times 10^{10} + j0.984 \times 10^{10}$. (e) $-0.026 + j0.01795$. (f) 10, $10/\underline{120^\circ}$, $10/\underline{240^\circ}$. (g) $1.93 + j0.518, -0.518 + j1.93, -1.93 - j0.518, 0.518 - j1.93$. (h) $2.28 - j0.439, -2.28 + j0.439$. (i) $-2.68 + j0.383$. (j) $0.9999995 + j0.00100$. (k) $0.0156/\underline{137.5^\circ}$. (20) (a) $2.79/\underline{34.3^\circ}$ (principal value). (21) (d) $8.62/\underline{23.8^\circ}$. (23) (d) $0.2 \cos(10^6 t - 183.1^\circ) + j0.2 \sin(10^6 t - 183.1^\circ)$ amp. (25) (d) -312 watts. (28) $0.01856/\underline{26.6^\circ}$ amp, $0.01856 \cos(120\pi t + 26.6^\circ)$ amp. (29) (a) 10 + $j10$ ohms, 10 ohms, 10 ohms. (32) (e) 1 + $j1.5$ mhos, 1 mho, 1.5 mhos. (34) 0.705 or 2.13 radians/sec. (37) 1 + $j0$ mhos.

Chapter 11 ♦ (1) $3.71/68.2^\circ$ amp, $3.71 \cos(\omega t + 68.2^\circ)$ amp. (4) $0.608/104.03^\circ$ amp, $0.608 \cos(\omega t + 104.03^\circ)$ amp. (9) $12.4 \cos(10t + 7.11^\circ) - 20 \cos 5t$ amp. (11) $0.051e^{-t/16} + 0.993 \cos(\frac{1}{2}t - 82.87^\circ)$ amp. (15) 0.0836 amp, 21.8° . (18) $42.2 \cos^2 \omega t$ watts. (21) (a) $2.90/112.7^\circ$ volts. (b) Box 1 is active. Box 2 may contain 2.12 ohms and 2.12 henrys in series. Box 3 may contain 1.414 ohms and 0.707 farad in series. (23) (b) $Z_B = 200/\pm 79.2^\circ$ ohms. Z_B might be 37.5 ohms in series with $0.811 \mu\text{f}$.

Chapter 12 ♦ (2) (a) $e^{-t}u(t)$ watts. (b) (1) 0.632 watt. (2) 0.233 watt. (3) 2.87×10^{-5} watt. (4) 4800 ohms, 255 volts. (6) 0.9975 radian/sec, 10.025 watts. (8) ± 15.41 amp. (10) 12.8 watts. (12) (a) 2.24 amp. (b) 20 watts. (c) $e_C(3) = 2.5$ volts. (14) (a) $10/60^\circ$ amp. (b) $10/-60^\circ$ amp. (c) $500/-89.43^\circ$ amp. (16) (a) 20 amp. (b) 400 volts. (c) 0.8. (18) $P_s = 150 - j50$ va, $P_C = -j500$ va, $P_L = j450$ va, $P_R = 150$ va. (21) 8 watts. (24) (a) 300 watts. (b) 75 var. (c) $3.09/16.0^\circ$ amp. (26) (a) 1 ohm. (b) 0 ohms or 0.5 ohm. (c) 1.5 ohms or 2 ohms.

Chapter 13 ♦ (1) (a) $Z_a(-3) = 1\frac{3}{8}$ ohms, $Z_b(-3) = 0$ ohms, $Z_c(-3) = \infty$ ohms. (b) $Z_a(j2) = 5.59 - j0.353$ ohms, $Z_b(j2) = 3.90 + j44.9$ ohms, $Z_c(j2) = 0.0215 + j0.469$ ohm. (2) $-e^{-2t}$ amp. (5) $-1.35e^{-106t}$ volts. (7) $2e^{-5t}$ volts. (10) (a) $1.053e^{-2t}$ amp. (12) $2.81 \cos(5t - 69.4^\circ) - 0.445e^{-3t}$ amp. (14) (a) $15e^{-5t}$ volts. (b) $15(e^{-5t} - e^{-25t})u(t)$ volts. (16) (b) See Fig. 6. (19) (a) An inductive path between the terminals must be present. (b) There must be a capacitor in every path between the terminals. (c) A capacitive path between the terminals must be present. (d) There must be an inductor in every path between the terminals. (20) (a) ∞ ohms. (b) 13.5 ohms. (c) 6.75 ohms. (d) 0 ohms. (24) See Fig. 7.

Chapter 14 ♦ (1) (a) $6.32 \cos(20t + 71.6^\circ)$ volts. (b) $120e^{-3t} \cos(20t + 30^\circ)$ volts. (4) (a) $-20e^{-20t}$ amp. (b) $20 \cos(10t - 53.1^\circ)$ amp. (c) $20e^{-15t} \cos(10t - 126.9^\circ)$ amp. (5) $16e^{-t/2} \cos(1.5t + 120^\circ)$ amp. (7) $20e^{-8t} \cos(4t - 96.9^\circ)$ amp. (9) (d) Pole at $s = 0$ and $s = \infty$, zeros at

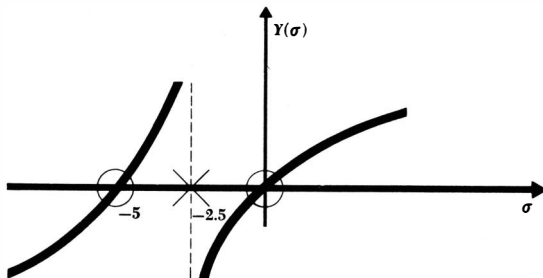

Fig. 6

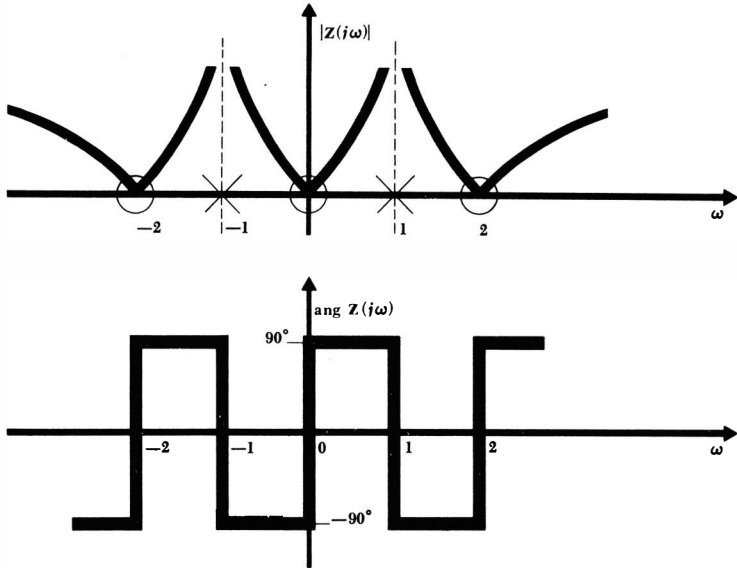
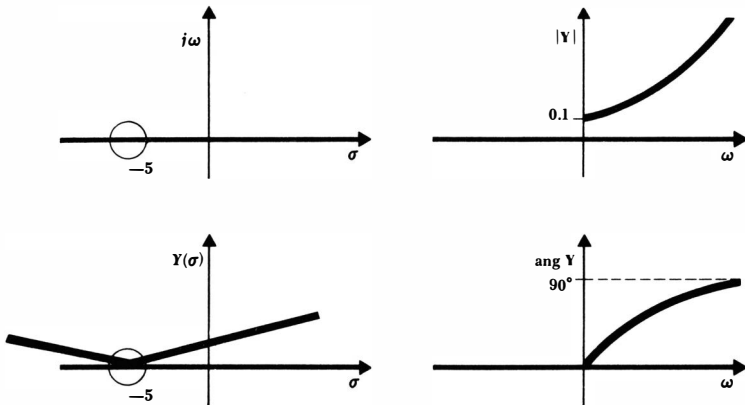

Fig. 7

$s = -2 \pm j4$. (10) (a) Pole at $s = -2$, zero at $s = 0$. (b) Poles at $s = 0$ and $s = -7$, zeros at $s = -2$ and $s = \infty$. (c) Poles at $s = 0$ and $s = \infty$, zeros at $s = -2 \pm j4$. (d) Poles at $s = -4$ and $s = -5$, zeros at $s = -3 \pm j1$. (e) Poles at $s = \pm j1$ and $s = \pm j1.732$, zeros at $s = 0, s = \infty$, and $s = \pm j1.414$. (12) See Fig. 8.

Fig. 8



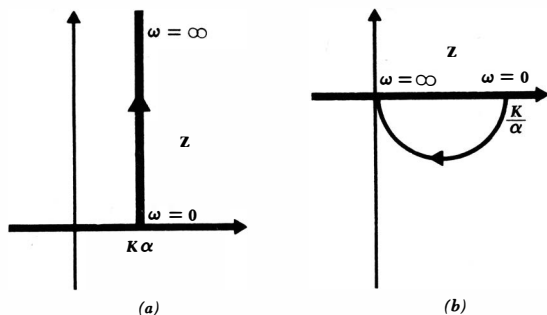

Fig. 9

(15) (a) $Z_a(s) = \frac{As}{s^2 + 6s + 10}$; $Z_b(s) = \frac{B(s + 2)}{s(s + 5)}$.

(b) $Y_a(s) = \frac{Ms}{s^2 + 6s + 10}$; $Y_b(s) = \frac{N(s + 2)}{s(s + 5)}$.

(c) $A = 1082, B = 1097, M = 0.1082, N = 0.1097$.

(17) (a) $1.414/15^\circ$ ohms. (b) $1.414/-15^\circ$ ohms. (c) $0.271/82.23^\circ$ ohms.

(21) (a) $Z(s) = (s^2 + 4s + 13)/s$. (23) (a) $Y(s) = 4(s^2 + 2s + 101)/s$.

(25) (a) $Z(s) = 3(s + 1)/(s + 4)$. (b) $8 - 6\epsilon^{-t}$ amp. (27) $12\epsilon^{-2t} - 2\epsilon^{-3t}$ volts. (29) $0.221\epsilon^{-t} \cos(2t + 45^\circ) + 0.0938\epsilon^{-3t}$ amp. (31) (d)

$i = A\epsilon^{-t} + B\epsilon^{-3t}$ amp.

Chapter 15 ♦ (1) (e) Z locus looks like Fig. 15-5a with intercept at $r = R_1$; Y locus looks like Fig. 15-5b with ω_0 at $g = 1/R_1$. (f) Z locus shown as Fig. 15-5b, $R = R_1$; Y locus shown as Fig. 15-5a, $1/R = 1/R_1$. (2) (a) and (b) See Fig. 9. (6) (a) and (b) See Fig. 10. (8) Resonant at $\omega = 0.5$. (11) (b) 30° . (c) 1.732 radians/sec. (14) See Fig. 11. (16) 1.00 radian/sec, 3.60 ohms. (19) See Fig. 12. (22) (a) Stable. (b) Unstable. (26) (b) $C = 1/(10^4 + 0.01\omega^2)$ farads. (28) (a) 6 radians/sec. (b) 0.955 cps. (c) 2. (d) 1.5 nepers/sec. (e) 5.81 radians/sec. (f) $-1.5 \pm j5.81$ sec⁻¹. (30) (a) 10 ohms, 1.327 mh, 0.00531 farad. (b) 50,000 ohms,

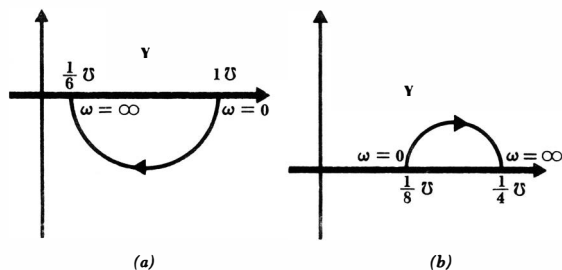

Fig. 10

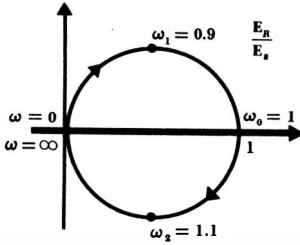

Fig. 11

2.5 mh, 0.01 μ f. (c) 0.16 ohm, 0.32 henry, 312 farads (32) 251.
 (34) 523. (36) $\mathfrak{B} = 20$ cps, $f_1 = 90.5$ cps, $f_2 = 110.5$ cps. (40) 12.5 $m\mu$ a. (42) (a) 10^6 radians/sec. (b) $-10, -5, -1, 0, 1, 5, 10$.
 (c) $-10.56, -5.10, -1.00, 0, 1.00, 4.90, 9.545$. (d) We think (b) is easier. (45) 40,000 ohms, 345 pf, 73.5 μ h. (47) 3 radians/sec.
 (49) (a) 999,000 radians/sec, $2 - j2$ ohms. (b) 9,937,000 radians/sec, $12.56 - j12.56$ ohms. (c) 0.990 radian/sec, $0.1 - j0.1$ ohm. (51) (a) Impedance of a series-resonant circuit. (b) $1.606/51.5^\circ$. (53) 1 ohm, 300 μ h, 3330 pf. (55) $22.4/-63.4^\circ$ ohms. (57) 4440 μ f, 5 ohms, 12.71 radians/sec, 17.71 radians/sec. (59) $135.1/42.25^\circ$ ohms. (61) (a) 100, 1, 50, 0.5. (65) (a) 10,000 radians/sec. (b) 50. (67) $-240, 6640$ cps. (69) (a) 5000 ohms, 0.005 farad, 0.32 ohm, 2 henrys. (70) (a) 250 ohms, 0.001 farad, 0.016 ohm, 1 mh. (71) (a) 12,500 ohms, 100 μ f, 0.8 ohm, 0.25 henry.

Chapter 16 ♦ (2) $i_1(t) = 10(1 - e^{-10t})u(t)$ amp, $e_2(t) = 800e^{-10t}u(t)$ volts.
 (4) $sL_1I_1 - sM_1I_2 = E_s, -sM_1I_1 + (sL_2 + sL_3)I_2 - sM_2I_3 = 0, -sM_2I_2 + (R + sL_4)I_3 = 0$. (7) (b) $L_1 + L_2 - 2M$. (d) $(L_1L_2 - M^2)/(L_1 + L_2 + 2M)$. (9) $3s(s^2 + 12)/2(s^2 + 3)$. (14) (a) 8 mh. (h) $4/90^\circ$ volts. (16) (a) 1.98 henrys. (18) $B_1 \cos 1.414t + B_2 \sin 1.414t + B_3 \cos 0.817t + B_4 \sin 0.817t$ amp. (20) (a) 100 radians/sec. (b) 87.2 and 120.8 radians/sec. (22) 13.33 watts. (24) $\frac{1}{25}, \frac{3}{25}, 400$ volts. (26) (a) $2.55/-6.91^\circ$ amp, $4.96/7.12^\circ$ amp. (b) $2.5/0^\circ$ amp, $5.0/0^\circ$ amp. (c) Answers reasonably close since $|Z_{L1}|$ and $|Z_{L2}|$ relatively large compared with any external impedances.

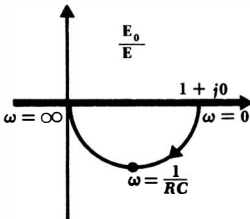

Fig. 12

Chapter 17 ♦ (1) (a) 18.2 watts. (b) 12.4 watts, 13.0 watts. (c) 0.658 amp. (d) 0.658 amp. (3) (a) $8.33(1 - \epsilon^{-0.2t})u(t)$ amp. (b) Same as (a). (5) $Z_{12} = k - R_2$, $Z_{21} = -R_2$.

$$(7) (a) y_{11} = \frac{3}{12 - k}, y_{12} = \frac{1}{k - 12}, y_{21} = \frac{k + 3}{3k - 36}, y_{22} = \frac{5}{36 - 3k}$$

(b) 1.95. (9) $y_{11} = -1.255 \times 10^{-3}$ mho, $y_{12} = 0.498 \times 10^{-6}$ mho, $y_{21} = 0.0649$ mho, $y_{22} = -8.51 \times 10^{-6}$ mho. (13) 3750 watts. (15) $h_{11} = 5$ ohms, $h_{12} = -h_{21} = 1$, $h_{22} = 0.1$ mho. (18) (a) $E_2 = 1$ volt, $E_1 = 0.233$ volt. (b) $E_1 = 0.0111$ volt, $E_2 = -0.333$ volt. (c) 2.5 ohms. (d) -10 ohms. (20) (a) $y_{11} = L_2/s(L_1L_2 - M^2)$, $y_{12} = y_{21} = -M/s(L_1L_2 - M^2)$, $y_{22} = L_1/s(L_1L_2 - M^2)$. (b) $z_{11} = sL_1$, $z_{12} = z_{21} = sM$, $z_{22} = sL_2$. (c) $h_{11} = s(L_1L_2 - M^2)/L_2$, $h_{12} = -h_{21} = M/L_2$, $h_{22} = 1/sL_2$. (22) 31 volts. (24) (a) g_m . (b) r_p . (c) $1/r_p$. (28) (a) -246Ω . (b) $-82,000\Omega$. (c) 19 ma. (d) -951 volts. (e) $-157,000$.

Chapter 18 ♦ (1) (a), (b), (c) 2 amp. (3) (a) 8. (5) 6. (8) (a) 3. (b) No. (c) 0 amp. (d) 0 amp. (10) (a) 7. (b) 5. (c) Fig. 18-21f only. (12) Clockwise around perimeter: 1.33 amp, 0.333 amp, 1 amp, 1.5 amp. Radially in: 1 amp, -0.667 amp, -0.5 amp, 0.1667 amp. (14) $I_x = 5$ amp, $I_y = 28$ amp. (17) 7.2 volts.

Chapter 19 ♦ (1) $E_{bc} = 150/75.5^\circ$ volts, $E_{ca} = 200/226.6^\circ$ volts. (3) 0.1642 ohm; neutral perhaps 0.5 ohm. (6) $P_{\text{upper line}} = 15.2$ watts, $P_{\text{center line}} = 29.9$ watts, $P_{\text{lower line}} = 16.8$ watts, $P_{\text{upper load}} = 274$ watts, $P_{\text{lower load}} = 302$ watts, Eff. = 90.4 per cent. (8) 15.7 amp. (10) 2625 watts. (12) (a) 13.22 ohms. (b) 7980 watts. (c) 283 volts rms. (14) (a) 9950 watts. (b) 28.8 amp rms. (16) (a) $50/-120^\circ$ volts. (b) $50/120^\circ$ volts. (c) $5/-30^\circ$ amp. (d) $5/-150^\circ$ amp. (e) $5/90^\circ$ amp. (f) $8.66/-60^\circ$ amp. (g) $8.66/-180^\circ$ amp. (h) $8.66/60^\circ$ amp. (18) (a) 217 watts, no reversal. (b) 217 watts, reversed. (c) 433 watts, reversed. (20) (a) 4 kw or 6 kw. (b) $\pm 49.1^\circ$ and $\pm 69.0^\circ$. (c) $3.26/\pm 69.0^\circ$ ohms and $3.96/\pm 49.1^\circ$ ohms. (22) (a) $18P^2R_p/E^2$ watts. (b) $2P^2R_s/E^2$ watts. (c) Yes. (d) Series system has one-ninth the weight and about one-ninth the conductor cost. (24) $P_{\text{upper}} = 1500$ watts, $P_{\text{lower}} = 1500$ watts, $P_{\text{total}} = 3000$ watts.

Chapter 20 ♦ (1) $i(t) = \frac{a}{T} + \frac{2}{\pi} \sum_{n=1}^{\infty} \frac{1}{n} \sin \frac{n\pi a}{T} \cos \frac{2\pi n t}{T}$ amp.

$$(3) e(t) = 5 - \frac{10}{\pi} \sum_{n=1}^{\infty} \frac{1}{n} \sin 20\pi n t \text{ volts.}$$

$$(5) (a) e = \frac{2E_m}{\pi} + \frac{4E_m}{\pi} \left(\frac{1}{3} \cos 10\pi t - \frac{1}{15} \cos 20\pi t + \frac{1}{35} \cos 30\pi t \right.$$

$\left. - \dots \right)$ volts.

(b) 0.214 farad.

(7) (a) $e_s = 25 + \frac{200}{\pi} \sum_{n=1}^{\infty} \frac{1}{n} \sin \frac{n\pi}{4} \cos \frac{5n\pi t}{2}$ volts. (b) $i(t) = \frac{1000}{\pi} \cos 5\pi t$ amp.

(10) $f(t) = 1.5 + 1.5 \cos 4t$. (12) (a) Even. (b) Even. (c) Even.

(14) $e = 10 - \frac{30}{\pi} \left(\sin \frac{20\pi t}{3} + \frac{1}{2} \sin \frac{40\pi t}{3} + \frac{1}{4} \sin \frac{80\pi t}{3} + \dots \right)$ volts.

(17) (a) $e_{Cf} = \sum_{n=1}^{\infty} \frac{8 \sin \frac{1}{2}\pi n}{n\pi \sqrt{1 + \pi^2 n^2}} \cos(\pi n t - \tan^{-1} \pi n)$.

(b) $e_{Cn} = A\epsilon^{-t}$.

(c) $e_C = -0.227\epsilon^{-t} + \sum_{n=1}^{\infty} \frac{8 \sin \frac{1}{2}\pi n}{n\pi \sqrt{1 + \pi^2 n^2}} \cos(\pi n t - \tan^{-1} \pi n)$.

(19) 100 kc, 707. (21) (a) Yes, although the frequency components in this band are very small. (b) Yes, the fundamental. The amplitude is probably negligible.

(24) (a) $f(t) = \frac{50}{\pi^2} \sum_{-\infty}^{\infty} \frac{(1 + j\pi n) \cos \pi n - 1}{n^2} \epsilon^{j2\pi n t}$.

Index

- A-c, 11
- Acceleration, units of, 6
- Active element, 19, 105
- Active network, 19
- Adjustable network, 444
- Admittance, 307–308, 402, 417
 - defined, 308
- Admittance combination, 308
- Admittance locus, 433
- Admittance parameters, 521
- Air-core transformer, 496
- Alternating current, 11
- Ammeter, 53 (prob.)
- Ampère, A. M., 105
- Ampere (unit), 10
- Amplitude, 267, 285
- Analog, electromechanical, 262
 - (prob.), 466
- Analog computer, 56
- Analysis, 22, 53 (prob.)
- Angular frequency, 267
- Apparent power, 355, 358
- Area, units of, 5
- Argument of function, 267, 285
- Atom, 7
- Auxiliary equation, 232

- Balanced three-phase system, 576
- Bandwidth, 451

- Battery, symbol for, 17
- Bilateral circuit, 525
- Bilateral element, 525
- Bilinear transformation, 436
- Branch, 25, 552

- Capacitance, 114–119, 121, 129,
220, 372, 402
 - defined, 114
 - energy in, 118–119
 - as open circuit, 119
 - as short circuit, 220
- Capacitance combination, 124
- Capacitor, 114
- Cavendish, Henry, 23
- Centi-, defined, 4
- Characteristic equation, 232
- Charge, 6–14, 26, 115, 121, 206
 - conservation of, 25, 121
 - units of, 8
- Circle, 436
- Circuit, 19, 27–28
 - defined, 19
- Circuit element, 12–16
 - general, 12, 16
 - simple, 16
- Coefficient of coupling, 493, 501
- Cofactor of determinant, 517
- Coil, 106

- Complementary function, 145, 181
- Complete response (*see* Response)
- Complex forcing function, 291
- Complex frequency, 234, 327, 394–396
- Complex frequency plane, 405, 416
- Complex impedance plane, 432
- Complex number, 278
 - exponential form, 284
 - polar form, 287
 - rectangular form, 280
- Complex plane, 279
- Complex power, 358
- Condenser (*see* Capacitor)
- Conductance, 24, 36, 130, 308
 - defined, 24
- Conductance determinant, 68
- Conductivity, 45 (prob.)
- Conjugate, 280, 395
- Conjugate complex pair, 280
- Conservation of charge, 25, 121
- Constellation, pole-zero, 410, 414, 439, 447
- Continuous spectrum, 620
- Controlled source (*see* Dependent source)
- Coulomb, Charles, 8
- Coulomb (unit), 8
- Cramer's rule, 63–64, 93 (prob.)
- Critical damping, 238–242
- Critical frequency, 379
- Current, 9–14, 26, 36, 121
 - alternating, 11
 - defined, 10
 - direct, 11, 17
 - displacement, 115
 - symbol for, 11
 - trapped, 154
- Current convention, 14
- Current division, 44
- Current impulse, 206–209
- Current source, ideal, 17, 75
 - practical, 72–77
- D-c, 11, 17
- Damping coefficient, exponential, 233, 369, 450
- Deci-, defined, 4
- Deka-, defined, 4
- Dependent source, 100 (prob.), 101 (prob.), 527
- Design, 22
- Determinant, 62–65, 517–518
 - cofactor of, 517
 - conductance, 68
 - minor of, 63, 517
 - order of, 64
 - resistance, 63
- Dimensional symbol, 5–6
- Direct current, 11, 17
- Displacement current, 115
- Dot convention, 483
- Double-subscript notation, 569
- Doublet, 174
- Drill problems discussed, 5
- Dual, 36, 128
 - exact, 36, 128
 - self-, 143 (prob.)
- Duality, 36, 87, 116, 119, 128–132, 403
- Dyne, 6

- Effective value, 351–354
- Electron, 7–12
- Element (*see* specific type of element)
- Energy, capacitive, 118–119
 - inductive, 112–113
 - mutual, 491
 - units of, 6
 - and voltage, 13
- Envelope, 250, 619
- Equations, linear (*see* Linear equations)
- Equivalent sources, 72, 75
- Erg, 6

- Euler's identity, 282
- Even symmetry, 607
- Exponential damping coefficient, 233, 369, 450
- Exponential form of complex number, 284

- Farad, 114
- Faraday, Michael, 105
- Feedback, 472
- Flux linkage, 211
- Force, units of, 6
- Forced response (*see* Response)
- Forcing function, 79, 174
 - complex, 291
 - damped sinusoidal, 398
 - exponential, 368
 - sinusoidal, 265
- Fourier, J. J., 602
- Fourier analysis, 602–619
- Fourier integral, 619
- Fourier series, 602–619
 - complex, 615
 - trigonometric, 602
- Fourier theorem, 266, 602
- Fourier transform, 621
- Frequency, 233, 267
 - angular, 267
 - complex, 234, 327, 394–396
 - critical, 379
 - cyclic, 396
 - half-power, 451
 - lower, 451
 - upper, 451
 - natural resonant, 243, 447, 450
 - neper, 233, 396
 - radian, 267, 396
 - resonant, 233, 446
- Frequency domain, 297, 371, 398
- Frequency scaling, 465
- Frequency selectivity, 452
- Friction, 167

- g** parameters, 548 (prob.)
- Giga-, defined, 4
- Giorgi, G., 4
- Graph, linear, 553
- Gravitation, 6–7
- Ground, 67

- h** parameters, 536
- Half-power frequency, 451
- Half-wave symmetry, 611
- Harmonic, 601, 610
- Hekto-, defined, 4
- Helix, 106
- Henry, Joseph, 105
- Henry (unit), 105
- Hybrid parameters, 536

- Ideal current source, 17, 75, 97 (prob.), 100 (prob.)
- Ideal transformer, 501
- Ideal voltage source, 17, 72–74, 97 (prob.), 100 (prob.)
- Imaginary number, 278
- Imaginary operator, 278
- Imaginary part, 278
- Imaginary unit, 278
- Immittance, 309
- Immittance locus, 431
- Impedance, 304–307, 371, 402, 417
 - defined, 305
 - input, 530
 - output, 530
 - reflected, 497, 503
- Impedance combination, 305
- Impedance locus, 432
- Impedance parameters, 532
- Impulse, 109 (*See also* Unit-impulse function)
- Independent equations, 59, 556–559
- Inductance, 105–113, 121, 130, 221, 372, 402, 481

- Inductance, defined, 105
 - energy in, 112–113
 - mutual, 482
 - as open circuit, 221
 - reciprocal, 499
 - self-, 481
 - as short circuit, 113
- Inductance combination, 122–123,
511 (prob.)
- Inductor, 105
- Initial conditions, 110, 116, 212–
215, 251–255
- Input impedance, 530
- Instantaneous value, convention
for, 8
- Integrating factor, 182, 240
- Internal resistance, 74

- Joule (unit), 6

- Kilo-, defined, 4
- Kilogram, 4
- Kirchhoff, G. R., 25
- Kirchhoff's current law, 25, 115,
120, 303
- Kirchhoff's voltage law, 27, 121,
303

- Lagging phase, 267
- Laplace transform, 162, 622
- Leading phase, 267
- Length, units of, 4–5
- Line current, 583
- Line spectrum, 618–620
- Line voltage, 577
- Linear circuit, 78–82, 84, 87, 90
 - defined, 78
- Linear element, 78
- Linear equations, algebraic, 62,
68, 78–80, 126
- Linear equations, differential, 181,
229
 - homogeneous differential, 145,
270
 - integrodifferential, 125
- Linear graph, 550
- Linear resistor (*see* Resistor)
- Linearity, 78–81, 133
- Link, 552
- Locus, 432
 - admittance, 433
 - immittance, 431
 - impedance, 432
- Loop, 56, 552
- Loop analysis, 554, 560
- Lower half-power frequency, 451

- Magnitude, 285
- Magnitude scaling, 465
- Mapping, 435
- Mapping theorem, 436
- Mass, units of, 4–5
- Mathematical models, 16, 23, 27,
105, 114, 115, 156
- Matrix, 63
- Maximum power transfer theorem,
49 (prob.)
- Maxwell, J. C., 115
- Mechanical units, 5
- Mega-, defined, 4
- Mesh, 56, 552
- Mesh analysis, 56–62, 125, 316,
373
- Mesh current, 57–59
- Meter, 4
- Mho, 24
- Micro-, defined, 4
- Milli-, defined, 4
- Minor of determinant, 63, 517
- Multiport network, 516
- Mutual inductance, 482
- Mutual resistance, 60

- Nano-, defined, 4
- Napier, J., 369
- Natural resonant frequency, 243, 447, 450
- Natural response (*see* Response)
- Neper, 369
- Neper frequency, 233, 396
- Network, adjustable, 444
 - defined, 19
 - distributed-constant, 25
 - lumped-constant, 25
 - multiport, 516
 - nonplanar, 56, 132
 - one-port, 516
 - planar, 56, 61, 70, 132
 - two-port, 521
- Neutral wire, 572, 576
- Neutron, 7
- Newton (unit), 6
- Nodal analysis, 66–71, 125, 316, 373, 557–562
- Node, 25, 67–71, 552
 - defined, 25, 552
 - reference, 67, 129
- Nonlinear circuit, 78, 90, 93 (prob.)
- Nonlinear resistor, 23, 38 (prob.), 93 (prob.), 99 (prob.), 101 (prob.), 194 (prob.)
- Nonlinear response, 81
- Nonperiodic function, 347
- Nonplanar network, 56, 132
- Norton, E. L., 82
- Norton's theorem, 82–90, 135, 197 (prob.), 326, 373, 403
- Nyquist diagram, 472
- Odd symmetry, 607
- Oersted, H. C., 105
- Ohm, G. S., 23
- Ohm (unit), 23
- One-port networks, 516
- Open-circuit voltage, 77
- Oscillatory function, 245
- Output impedance, 530
- Overdamping, 234–238
- Parallel connection, 35
- Parallel resonance, 445
- Particular solution, 181–183
- Passive element, 19, 105
- Passive network, 19
- Period, 267, 342
- Periodic function, 342, 601
- Permeability, 106
- Permittivity, 115
- Phase angle, 268°
- Phase current, 582
- Phase sequence, 577
- Phase voltage, 576
- Phasor, 296, 403
- Phasor diagram, 328
- π - T transformation, 540 (prob.)
- Pico-, defined, 4
- Planar network, 56, 61, 70, 132
- Polar form of complex number, 287
- Pole, 378, 405, 417
- Polyphase circuits, 568
- Port, 516
- Potential difference, 13
- Power, apparent, 355, 358
 - average, 341–348, 359
 - complex, 358
 - instantaneous, 14, 24, 339–341
 - reactive, 358
 - units of, 6
- Power convention, 13
- Power factor, 355
- Power-factor angle, 356
- Power measurement, 349–351, 586–592
- Practical current source, 72–77
- Practical voltage source, 40, 72–77

- Primary, 496
- Problems, drill, discussed, 5
- Proton, 7

- Q , 448
- Quadrature component, 359
- Quality factor, 448

- Radian frequency, 267, 396
- Reactance, 273, 306
 - defined, 306
- Reactive power, 358
- Real part, 278
- Reciprocal inductance, 499
- Reciprocity, 491
- Reciprocity theorem, 525, 539
 - (prob.)
- Rectangular form of complex number, 280
- Reference node, 67, 129
- Reflected impedance, 497, 503
- Resistance, 36, 130, 306, 371, 402
 - defined, 23
 - internal, 74
 - mutual, 60
 - negative, 374
 - self-, 60
- Resistance combination, 37–40
- Resistance determinant, 63
- Resistivity, 45 (prob.)
- Resistor, 23
 - nonlinear, 23, 38 (prob.)
 - symbol, 23
- Resonance, defined, 445
 - parallel, 445
 - series, 456
- Resonant frequency, 233, 446
- Response, complete, 180–183, 250, 375, 493, 612
 - forced, 18–183, 265, 270, 369, 375
 - natural, 145, 180–183, 265, 375, 416
 - steady-state (*see* forced, *above*)
- Response function, 79
- Right-hand rule, 485
- Rms value, 352–354
- Rubber sheet model, 409

- s plane, 405, 416
- Sampling function, 617
- Scaling, 464
 - frequency, 465
 - magnitude, 465
- Second, 4
- Second-order system, 229–230
- Secondary, 496
- Selectivity, frequency, 452
- Self-dual, 143 (prob.)
- Self-inductance, 481
- Self-resistance, 60
- Semi-infinite straight line, 432
- Series connection, 31
- Series resonance, 456
- Settling time, 237, 451
- Short-circuit current, 76
- Sifting integral, 203
- Single-phase three-wire system, 571
- Singularity function, 174
- Sinusoid, 267–269
 - exponentially damped, 244, 393
- Sinusoidal forcing function, 270–273
- Source combination, 38–40
- Source-free response (*see* Response, natural)
- Source transformations, 72–77, 197 (prob.), 323, 403
- Spectrum, continuous, 620
 - line, 618, 620
- Steady-state response (*see* Response, forced)
- Sufficiency, 556, 559

- Superposition theorem, 48 (prob.),
 78–82, 133, 197 (prob.), 322,
 348, 373, 402
 Susceptance, 308
 Symmetry, in determinants, 71
 even-function, 607
 half-wave, 611
 odd-function, 607
 Synthesis, 22, 53 (prob.)
 Systems of units (*see* Units)
- Tera-, defined, 4
 Terminals, 12, 27
 Thévenin, M. L., 82
 Thévenin resistance, 87, 89, 530
 Thévenin's theorem, 82–87, 135,
 197 (prob.), 326, 373, 403
 Three-phase systems, 576–592
 Time, 4–5
 Time constant, 150, 157, 180, 376
 Time domain, 297, 371
 Time-invariant circuit, 213
 Topology, 547–553
 defined, 550
 Transformer, 496–508
 air-core, 496
 defined, 496
 equivalent networks for, 498
 ideal, 501
 Transient response (*see* Response,
 natural)
 Trapped current, 154
 Trapped voltage, 160, 189
 Tree, 552
 Turns ratio, 502
 Two-phase system, 574
 Two-port networks, 521
- Unbalanced three-phase system,
 586
 Underdamping, 242–245
- Unit doublet, 209
 Unit impulse, symbol for, 203
 Unit-impulse function, 174, 201
 Unit-step function, 174, 204
 Units, 4–6
 fundamental, 4
 mechanical, 5
 standard, 3
 systems of, 3–5
 British, 5
 rationalized mks, 4
 Upper half-power frequency, 451
- Va (volt-ampere), 355
 Var (volt-ampere reactive), 359
 Velocity, 5
 Volt, 13
 Voltage, 13–14, 27, 36
 defined, 13
 symbol for, 13
 trapped, 160, 189
 Voltage convention, 14
 Voltage division, 43
 Voltage impulse, 210–212
 Voltage source, ideal, 17, 72–74
 practical, 40, 72–77
 Voltmeter, 53 (prob.)
- Watt, 6
 Wattmeter, 349–351
 Work, 6
- y parameters, 521
 Y- Δ transformation, 540 (prob.)
 Yrneh, 500
- z parameters, 532
 Zero, 379, 405, 417



**Other McGraw-Hill INTERNATIONAL STUDENT EDITIONS
in Related Fields:**

ATWATER: **Introduction to Microwave Theory**
CAGE: **Theory and Application of Industrial Electronics**
CARROLL: **Electron Devices and Circuits**
DAWES: **A Course in Electrical Engineering, Vol. I, 4th Ed.**
DAWES: **A Course in Electrical Engineering, Vol. II, 4th Ed.**
DAWES: **Industrial Electricity, Vol. I, 3rd Ed.**
EVERITT: **Communication Engineering, 3rd Ed.**
FITZGERALD: **Basic Electrical Engineering, 3rd Ed.**
FITZGERALD: **Electrical Machinery, 2nd Ed.**
GRAY: **Principles and Practice of Electrical Engineering, 8th Ed.**
GREINER: **Semiconductor Devices and Applications**
GROB: **Basic Electronics, 2nd Ed.**
HAMMING: **Numerical Methods For Scientists And Engineers**
JOHNSON: **Transmission Lines and Networks**
KIVER: **Transistors, 3rd Ed.**
LANGSDORF: **Principles of Direct Current Machines, 6th Ed.**
LANGSDORF: **Theory of Alternating Current Machinery, 2nd Ed.**
MARCUS: **Elements of Radio Servicing, 3rd Ed.**
MILLMAN: **Pulse, Digital, and Switching Waveforms.**
RAVEN: **Automatic Control Engineering, 2nd Ed.**
RYDER: **Engineering Electronics, 2nd Ed.**
SCOTT: **Analog and Digital Computer Technology**
SEELY: **Electron-Tube Circuits, 2nd Ed.**
SEELY: **Radio Electronics**
SLURZBERG: **Essentials of Radio Electronics, 2nd Ed.**
SOKOLNIKOFF: **Advanced Calculus**
SPANGENBERG: **Fundamentals of Electron Devices**
STEVENSON: **Elements of Power System Analysis, 2nd Ed.**
STILL: **Elements of Electrical Machine Design, 3rd Ed.**
TERMAN: **Electronic Measurements, 2nd Ed.**
TERMAN: **Electronic and Radio Engineering, 4th Ed.**
THALER: **Analysis and Design of Feedback Control Systems, 2nd Ed.**
WYLIE: **Advanced Engineering Mathematics, 3rd Ed.**